

Precise   Stable   Durability   High Rigidity

**Meet the Multi-Demand of Accuracy and Efficiency**





# Mono Stage



## A. Construction

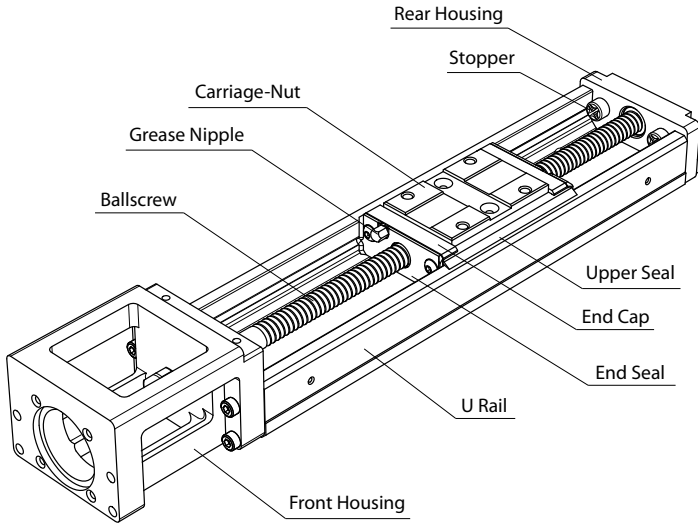

## B. Characteristics

KM series consist of linear guideway unit and ballscrew unit. For saving space, **PMI** combine the carriage of linear guideway and nut of ballscrew to a integral Carriage-Nut. The carriage-nut cooperate with the U rail designed for high rigidity to achieve the high rigidity and high accuracy in the minimal space, especially to saving time of installation. Moreover, the design of two rows with Gothic-arch groove and contact angle of  $45^\circ$  can bear four directional loading.

### Four Directional Equal Load

KM series are applied two rows with Gothic-arch groove and designed to contact angle of  $45^\circ$  which enables it to carry an equal load in radial, reversed radial and lateral directions to suit to any mounting orientation.

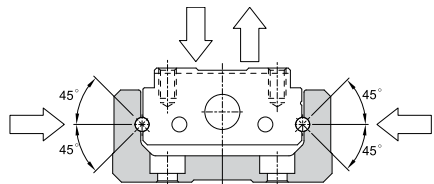

## Saving Space

Combine the carriage of linear guideway and nut of ballscrew to a carriage-nut, KM series can achieve the best use of space.

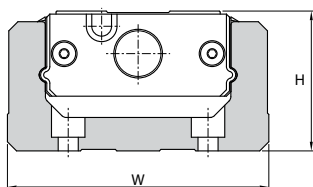

Unit : mm

Model	H	W
KM20	20	40
KM26	26	50
KM30	30	60
KM 33	33	60
KM 45	45	80
KM 46	46	86
KM 55	55	100
KM 65	65	130

## High Rigidity

Base on the optimal analysis of FEM for the shape of U rail, it has the balance between light weight and high rigidity.

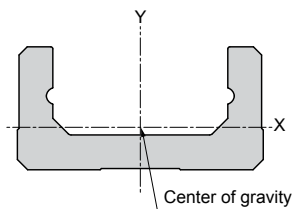
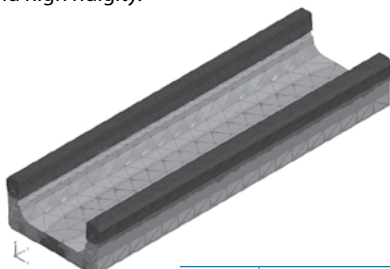

Unit : mm<sup>4</sup>

Model	I <sub>x</sub>	I <sub>y</sub>
KM20	5.8×10 <sup>3</sup>	6.0×10 <sup>4</sup>
KM26	1.6×10 <sup>4</sup>	1.5×10 <sup>5</sup>
KM30	4.4×10 <sup>4</sup>	3.3×10 <sup>5</sup>
KM 33	6.1×10 <sup>4</sup>	3.8×10 <sup>5</sup>
KM 45	1.5×10 <sup>5</sup>	1.1×10 <sup>6</sup>
KM 46	2.5×10 <sup>5</sup>	1.6×10 <sup>6</sup>
KM 55	2.3×10 <sup>5</sup>	2.3×10 <sup>6</sup>
KM 65	4.7×10 <sup>5</sup>	5.9×10 <sup>6</sup>

Note\* I<sub>x</sub> : Geometrical moment of inertia around X axis  
I<sub>y</sub> : Geometrical moment of inertia around Y axis

## High Accuracy

The design of two rows with Gothic-arch groove and stable manufacturing technology can control the variation by load at the minimum. It can provide the smooth feed with high accuracy.

## C. Carriage-Nut Type

**A Type** : A single carriage-nut with standard length

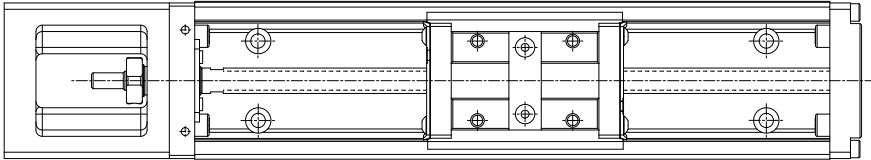

**B Type** : Two carriage-nuts with standard length

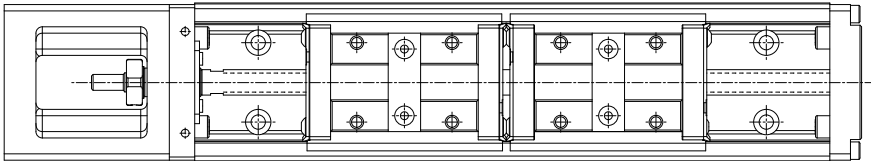

**C Type\*** : A single carriage-nut with short length

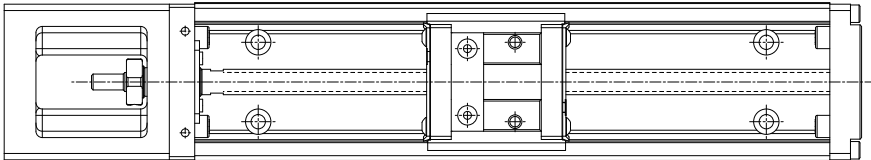

**D Type\*** : Two carriage-nuts with short length

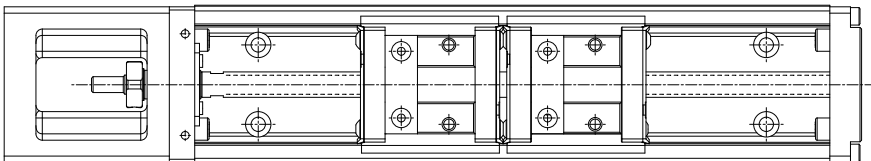

\* C and D type are only optional for KM30, KM33, KM45 and KM46 model.

## D. Description of Specification

	KM33	05	A	+400	P	0	-0	0	30	CA	AA
Model											
Ballscrew Lead											
Carriage-Nut type											
<b>A:</b> A single carriage-nut with standard length											
<b>B:</b> Two carriage-nuts with standard length											
<b>C:</b> A single carriage-nut with short length											
<b>D:</b> Two carriage-nuts with short length											
Rail length (mm)											
Accuracy grade											
<b>N:</b> Normal grade											
<b>H:</b> High grade											
<b>P:</b> Precision grade											
With / Without a Motor											
<b>0:</b> None											
<b>1:</b> With a Motor (mounted at <i>PMI</i> )											
With / Without a Cover											
<b>0:</b> None											
<b>1:</b> With a Cover											
<b>2:</b> With a Bellows											
Sensor Specification (see page C15)											
Type of Motor Bracket type (see page C17)											
Surface treatment mode:											
No symbol : Fluoride low temperature chrome											
<b>CB : Black oxide treatment</b>											
<b>CA :</b> Electroless Nickel											
Code of special type											
<b>AA :</b> Special process											

## E. Load Ratings

The load ratings of KM series are divided to linear guideway and ballscrew, the load ratings of each part are shown below.

Model		Linear Guideway				Ballscrew							
		Basic dynamic load rating C (kN)		Basic static load rating C <sub>0</sub> (kN)		Basic dynamic load rating C <sub>a</sub> (kN)		Basic static load rating C <sub>0a</sub> (kN)		Ballscrew diameter (mm)	Lead (mm)	Thread minor diameter (mm)	Ball center to center diameter (mm)
		A \ B	C \ D	A \ B	C \ D	Normal N	High, Precision H \ P	Normal N	High, Precision H \ P				
KM 20	KM 20 01	4.75	-	8.33	-	0.76	0.76	1.26	1.26	6	1	7.8	8.1
	KM 20 02					0.6	0.6	0.9	0.9		2	7.8	8.1
KM 26	KM 26 02	7.99	-	15.23	-	2.50	2.50	4.02	4.02	8	2	6.6	8.3
	KM 26 06					1.18	1.18	1.67	1.67		6	6.6	8.3
KM 30	KM 30 05	12.21	7.91	22.11	11.90	2.94	2.94	5.10	5.10	12	5	10.3	12.4
	KM 30 10					2.84	2.84	4.51	4.51		10	9.9	12.4
KM 33	KM 33 05	12.21	7.91	22.11	11.90	2.94	2.94	5.10	5.10	12	5	10.3	12.4
	KM 33 10					2.84	2.84	4.51	4.51		10	9.9	12.4
KM 45	KM 45 10	26.35	16.26	46.65	23.33	6.66	6.66	11.86	11.86	15	10	12.3	15.6
	KM 45 20					5.00	5.00	8.53	8.53		20	12.3	15.6
	KM4520C					4.40	4.40	7.30	7.30		20	12.3	15.6
KM 46	KM 46 10	26.35	16.26	46.65	23.33	6.66	6.66	11.86	11.86	15	10	12.3	15.6
	KM 46 20					5.00	5.00	8.53	8.53		20	12.3	15.6
	KM4620C					4.40	4.40	7.30	7.30		20	12.3	15.6
KM 55 20		36.73	-	65.29	-	6.08	6.08	12.15	12.15	20	20	17.3	20.6
KM 65 25		50.75	-	81.62	-	9.02	9.02	18.91	18.91	25	25	21.6	25.7



## F. Static Permissible Moments

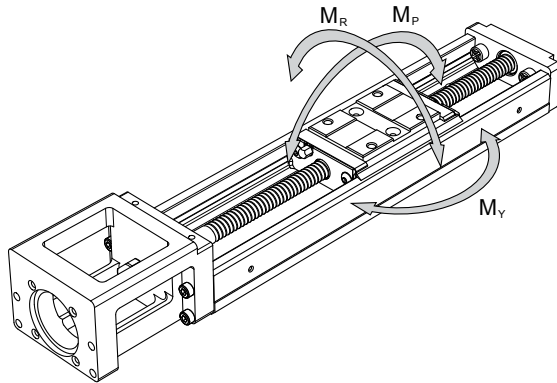

Unit : N-m

Model		Static Permissible Moments											
		M <sub>P</sub>				M <sub>Y</sub>				M <sub>R</sub>			
		A	B	C	D	A	B	C	D	A	B	C	D
KM 20	KM 20 01	38.2	192.6	-	-	38.2	192.6	-	-	114.6	229.1	-	-
	KM 20 02												
KM 26	KM 26 02	107.3	501.8	-	-	107.3	501.8	-	-	278.6	557.3	-	-
	KM 26 06												
KM 30	KM 30 05	156.6	858.5	43.8	326.4	156.6	858.5	43.8	326.4	462.0	924.0	248.8	497.6
	KM 30 10												
KM 33	KM 33 05	156.6	858.5	43.8	326.4	156.6	858.5	43.8	326.4	462.0	924.0	248.8	497.6
	KM 33 10												
KM 45	KM 45 10												
	KM 45 20	575.0	2678.0	120.0	1245.6	575.0	2678.0	120.0	1245.6	1334.2	2668.5	762.4	1524.8
	KM 4520C												
KM 46	KM 46 10												
	KM 46 20	575.0	2678.0	120.0	1245.6	575.0	2678.0	120.0	1245.6	1397.9	2795.8	798.8	1597.6
	KM 4620C												
KM 55	KM 55 20	858.4	4617.2	-	-	858.4	4617.2	-	-	2347.2	4694.4	-	-
	KM 65 25	1299.6	7001.3	-	-	1299.6	7001.3	-	-	3917.9	7835.8	-	-

Note\*: The static permissible moments of B and D type are base on two carnage nuts used in closed contact with each other.

## G. Accuracy Grade

KM series is classified into normal grade (N) , high (H) and precision grade (P), the standards are shown below.

Model	Rail Length (mm)	Positioning Repeatability (mm)			Positioning Accuracy (mm)			Running of Parallelism(mm)			Backlash (mm)			Starting Torque (N-cm)		
		Nomal N	High H	Precision P	Nomal N	High H	Precision P	Nomal N	High H	Precision P	Nomal N	High H	Precision P	Nomal N	High H	Precision P
KM 20	100															
	150	±0.01	±0.005	±0.003	-	0.06	0.02	-	0.025	0.01	0.02	0.01	0.003	0.5	0.5	1.2
	200															
KM 26	150															
	200	±0.01	±0.005	±0.003	-	0.06	0.02	-	0.025	0.01	0.02	0.01	0.003	2	1.5	4
	250															
	300															
KM 30	150															
	200															
	300	±0.01	±0.005	±0.003	-	0.06	0.02	-	0.025	0.01	0.02	0.02	0.003	7	7	15
	400															
	500					0.1	0.025		0.035	0.015						
600																
KM 33	150															
	200															
	300	±0.01	±0.005	±0.003	-	0.06	0.02	-	0.025	0.01	0.02	0.02	0.003	7	7	15
	400															
	500					0.1	0.025		0.035	0.015						
600																
KM 45	340															
	440															
	540					0.1	0.025		0.035	0.015						15
	640	±0.01	±0.005	±0.003	-			-			0.02	0.02	0.003	10	10	
	740															17
	840					0.12	0.03		0.04	0.02						25
940					0.15	0.04		0.05	0.03							
KM 46	340															
	440															
	540					0.1	0.025		0.035	0.015						15
	640	±0.01	±0.005	±0.003	-			-			0.02	0.02	0.003	10	10	
	740															17
	840					0.12	0.03		0.04	0.02						25
940					0.15	0.04		0.05	0.03							
KM 55	980															
	1080					0.18	0.035		0.025							17
	1180	±0.01	±0.005	±0.005	-	0.25	0.04	-	0.05	0.03	0.05	0.05	0.003	12	12	20
	1280															23
	1380					0.25	0.05		0.035	0.04				15		25

Model	Rail Length (mm)	Positioning Repeatability (mm)			Positioning Accuracy (mm)			Running of Parallelism(mm)			Backlash (mm)			Starting Torque (N-cm)			
		Nom N	High H	Precision P	Nom N	High H	Precision P	Nom N	High H	Precision P	Nom N	High H	Precision P	Nom N	High H	Precision P	
KM 65	980					0.18											
	1180	±0.01	±0.008	±0.005	-	0.035		-	0.05	0.025	0.05	0.05	0.005	12	12	20	
	1380					0.2											
	1680	±0.012				0.28	0.04		0.055	0.03				15	15	22	

## H. Maximum Travel Speed and the Maximum Length

KM series is limited by the dangerous speed of the ballscrew and the DN value regardless, the maximum travel speed and the maximum length are shown below. Unit : mm

Model	Ballscrew Lead	Rail Length	Maximum Travel Speed (mm/s)			Maximum Length		
			Normal N	High H	Precision P	Normal N	High H	Precision P
KM 20	1	100						
		150	137	137	190	200	200	200
		200						
		100						
KM 26	2	150	273	273	383	200	200	200
		200						
		250	280	280	280	300	300	300
		300						
KM 30	5	150						
		200						
		300	390	390	550	600	600	600
		400						
KM 33	5	500						
		600	340	340	340			
		150						
		200						
KM 33	10	200						
		300	790	790	1100	600	600	600
		400						
		500			980			
KM 33	600	600	650	650	650			
		150						
		200						
		300	390	390	550	600	600	600
KM 33	5	400						
		500						
		600	340	340	340			
		150						

Model	Ball screw Lead	Rail Length	Maximum Travel Speed (mm/s)			Maximum Length				
			Normal N	High H	Precision P	Normal N	High H	Precision P		
KM 33	10	150	790	790	1100	600	600	600		
		200								
		300								
		400			980					
		500								
600	650	650	650							
KM 45	10	340	520	520	740	940	940	740		
		440								
		540								
		640			730					
		740								
	840	430	430	-						
	20	340	1050	1050	1480	940	940	740		
		440								
		540								
		640			1440					
740										
840	840	840	-							
KM 46	10	340	520	520	740	940	940	740		
		440								
		540								
		640			730					
		740								
	840	430	430	-						
	20	340	1050	1050	1480	940	940	740		
		440								
		540								
		640			1440					
740										
840	840	840	-							
KM 55	20	980	800	800	1120	1380	1380	1180		
		1080			900					
		1180			740				740	
		1280			620				620	-
		1380			530				530	-
KM 65	25	980	800	800	1120	1680	1680	1380		
		1180			830					
		1380			-					
		1680			550				500	-

## I. Life Calculation

KM series consists of a linear guideway, a ballscrew and a support bearing. The calculation of nominal life of each component is shown below. The nominal life is defined as the total running distance that 90% of identical linear guideways or ballscrew in a group, when they are applied under the same conditions, can work without developing flaking.

### Linear Guideway

$$L = \left( \frac{f_c}{f_w} \cdot \frac{C}{P} \right)^3 \times 50 \text{ km}$$

L : Nominal life (km)  
 $f_c$ : Contact factor (see Table 1)  
 $f_w$ : Load factor (see Table 2)  
 C: Basic dynamic load rating (N)  
 P: Calculated applied load (N)

Carriage-Nut Type	Contact factor $f_c$
A \ C	1.00
B \ D	0.81

### Ballscrew and Bearing

$$L = \left( \frac{1}{f_w} \cdot \frac{C_a}{P_a} \right)^3 \times 10^6 \text{ rev}$$

L: Nominal life (rev)  
 $f_w$ : Load factor (see Table 2)  
 $C_a$ : Basic dynamic load rating (N)  
 $P_a$ : Applied axial load (N)

Motion Condition	Operating Speed	Load factor $f_w$
No Impact & Vibration	$V \leq 15\text{m/min}$	1.0~1.2
Slight Impact & Vibration	$15 < V \leq 60\text{m/min}$	1.2~1.5
Moderate Impact & Vibration	$60 < V \leq 120\text{m/min}$	1.5~2.0
Strong Impact & Vibration	$V \geq 120\text{m/min}$	2.0~3.5

## J. Options

---

### Cover

KM series provides cover and transfer seat option. The detail size could be referred by specification tables of product, please.

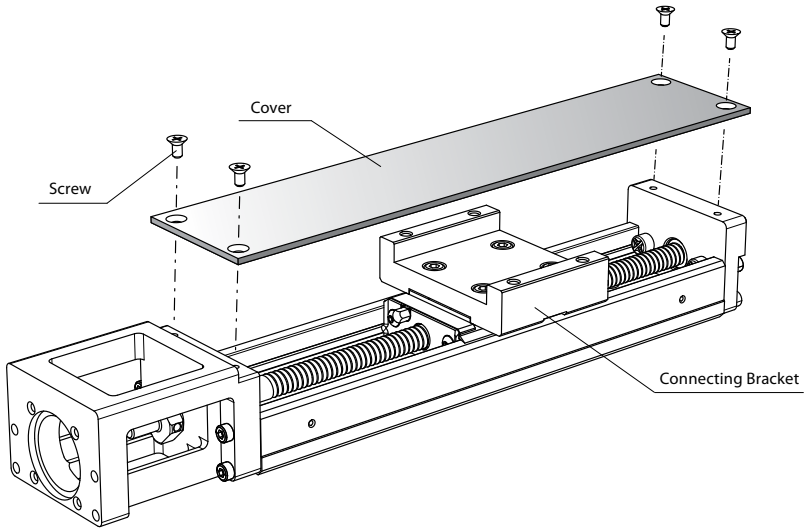

### Bellows

For KM series, a bellows is available for option. Please contact *PMI*.

## Sensor

For KM series, a optional proximity sensors and photo sensors are available as an option. Models equipped with a sensor are provided with a dedicated sensor rail / detecting plate. Please see the table below.

Symbol	Description	Type	Accessory
0	None	-	-
1	with Sensor rail	-	Mounting Screw
2	Photo sensor (3 units)	EE-SX671 (Omron)	Mounting Screw / Nut, Detecting Plate, Sensor Rail, Mounting Plate, Connector (EE-1001)
3	Photo sensor (3 units)	EE-SX674 (Omron)	Mounting Screw / Nut, Detecting Plate, Sensor Rail, Mounting Plate, Connector (EE-1001)
4	Proximity sensor a-contact (On when close, 3 units)	GX-F12A(Panasonic)	Mounting Screw/Nut \ Detecting Plate \ Sensor Rail
5	Proximity sensor b-contact (On when away, 3 units)	GX-F12B(Panasonic)	Mounting Screw/Nut \ Detecting Plate \ Sensor Rail
A	Proximity sensor a-contact (Single) b-contact (Double)	GX-F12A(Single) \ GX-F12B(Double)	Mounting Screw/Nut \ Detecting Plate \ Sensor Rail

**The dimension of installation for sensor:**

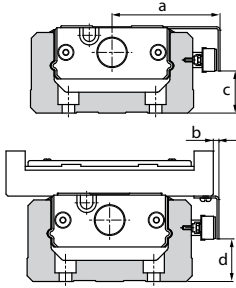

**Panasonic GX-F12A \ GX-F12B**

Model	a	b	c	d
KM 20	34.2	8.2	3.5	3.5
KM 26	38.9	7.9	6.2	6.2
KM 30	44	4	8.2	8.2
KM 33	44	1	9.2	10
KM 45	54.0	2.0	13.2	13
KM 46	57.0	1.0	22.2	23
KM 55	64	2	21.2	22.7
KM 65	79.0	-6.0	23.3	23.3

Unit : mm

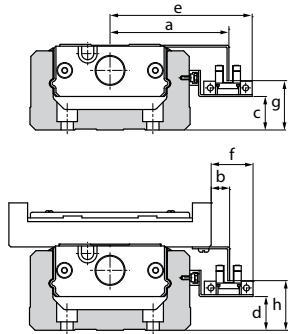

**Omron EE-SX671**

Model	a	b	c	d	e	f	g	h
KM 20	41	15	1.5	1.5	53.5	27.5	8	8
KM 26	46.0	15.0	2.0	2.0	58.5	27.5	10.5	10.5
KM 30	50.9	10.9	3.8	3.8	63.4	23.4	12.8	14
KM 33	50.9	7.9	5.0	5.0	63.4	20.4	13.8	15
KM 45	60.5	8.9	8.8	8.8	73.4	21.4	17.7	19
KM 46	63.9	7.9	18.0	18.0	76.4	20.4	26.5	28
KM 55	72	8.8	17.0	17.0	83.3	21.3	25.5	27
KM 65	85.8	0.8	19.0	19.0	98.3	13.3	27.7	27.7

Unit : mm

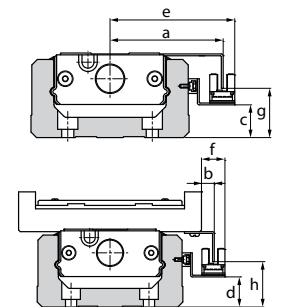

**Omron EE-SX674**

Model	a	b	c	d	e	f	g	h
KM 20	38.7	12.7	1.3	1.3	45	19	8.5	8.5
KM 26	43.7	12.7	1.8	1.8	50.0	19.0	10.8	10.8
KM 30	48.6	8.6	3.6	3.6	54.9	14.9	12.8	12.6
KM 33	48.6	5.6	4.8	4.8	54.9	11.9	13.8	14
KM 45	58.6	6.6	8.8	8.8	64.9	12.9	18.2	19.3
KM 46	61.6	5.6	17.8	17.8	67.9	11.9	26.8	28.1
KM 55	68.5	6.9	16.8	16.8	74.8	12.8	26.8	27.5
KM 65	83.5	-1.5	19.0	19.0	89.8	4.8	28.3	28.3

Unit : mm



**The dimension of sensor rail:**

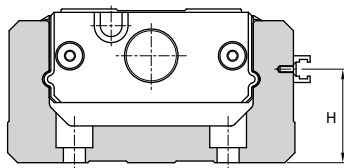
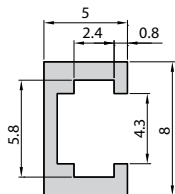

Model	H
KM 20	9.5
KM 26	12
KM 30	14
KM 33	15
KM 45	19
KM 46	28
KM 55	27
KM 65	30

**Intermediate Flange**

KM series allow different motors to be attached by intermediate flange. Please see the table below when ordering. Unit : mm

Brand of Motor	Model	KM 20	KM 26	KM 30	KM 33	KM 45	KM 46	KM 55	KM 65
Yaskawa Electric AC servomotor	SGMAH-A3(30W)	1A	2A	3A	3A	4A	4A		
	SGMAH-A5(50W)	1A	2A	3A	3A	4A	4A		
	SGMAH-01(100W)			3A	3A	4A	4A		
	SGMPH-01(100W)					40	40	50	6C
	SGMAH-02(200W)					40	40	50	6C
	SGMAH-04(400W)					40	40	50	6C
	SGMPH-02(200W)							5C	60
	SGMPH-04(400W)							5C	60
	SGMAH-08(750W)							5C	6G
Mitsubishi Electric AC servomotor	HC-MFS053(50W)	1A	2A	3A	3A	4A	4A		
	HC-MFS13(100W)			3A	3A	4A	4A		
	HC-MFS23(200W)					40	40	50	6C
	HC-KFS23(200W)					40	40	50	6C
	HC-MFS43(400W)					40	40	50	6C
	HC-KFS43(400W)					40	40	50	6C
	HC-MFS73(750W)							5C	6G
	HC-KFS73(750W)							5C	6G
Matsushita Electric AC servomotor	MSMD5A(50W)	1D	2D	3D	3D	4D	4D		
	MSMD01(100W)			3D	3D	4D	4D		
	MSMD02(200W)						40		
	MSMD04(400W)						40		
	MSMD08(750W)								5F 6F
Fastech Stepping motor	EzM-28	1G	2G						
	EzM-42	1H	2H	3H	3H	4H	4H		
	EzM-56			3I	3I	4I	4I		
	EzM-60			3J	3J	4J	4J		
Oriental Motor Stepping motor	PK22	1G	2G						
	PK24	1H	2H	3H	3H	4H	4H		
	PK26(Standard)			3I	3I	4I	4I		
	RK54	1H	2H	3H	3H	4H	4H		
	RK56			3J	3J	4J	4J		
	RK59							5K	6K

The dimension of intermediate flange:

KM20

10

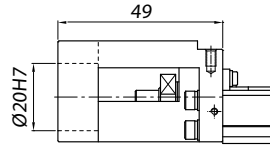
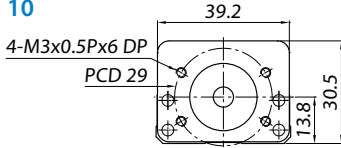

1A

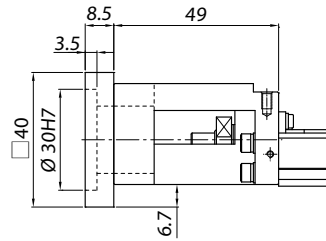
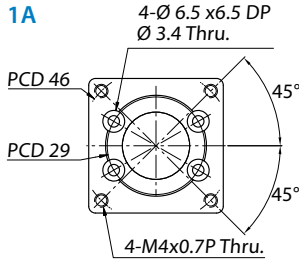

1D

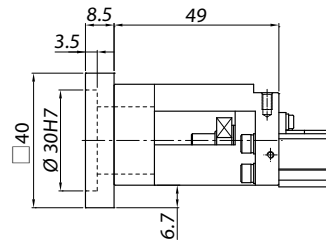
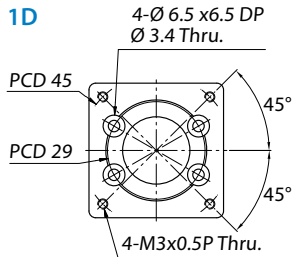

1G

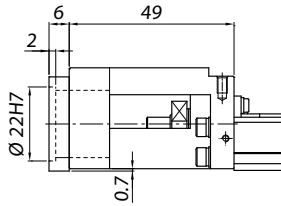
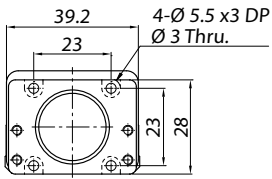

1H

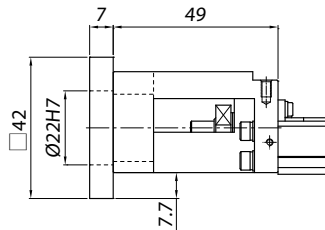
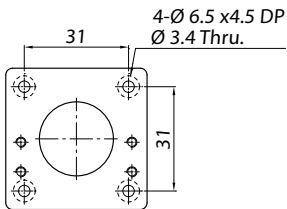

KM26

20

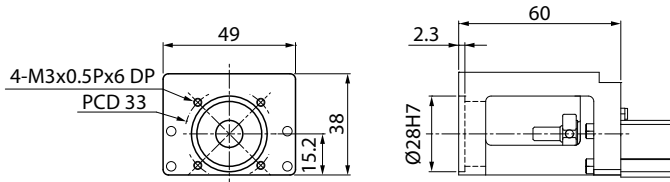

2A

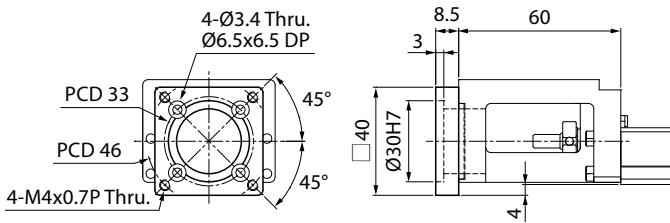

2D

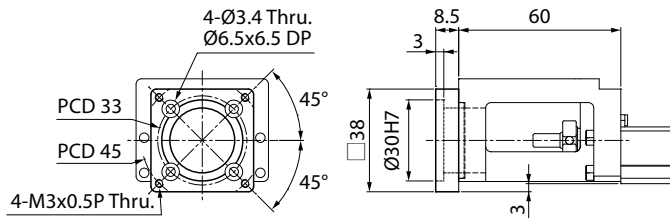

2G

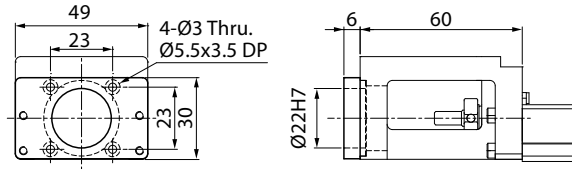

2H

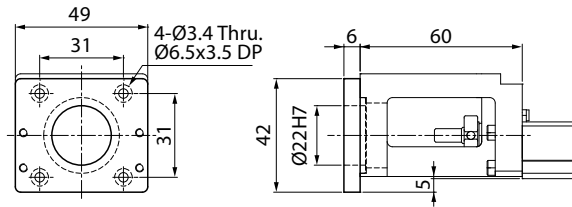

KM30

30

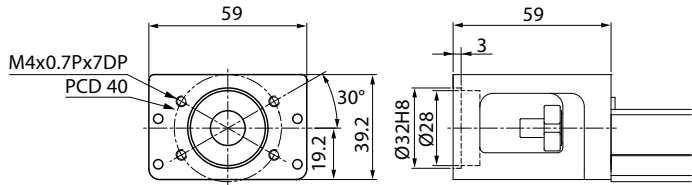

3A

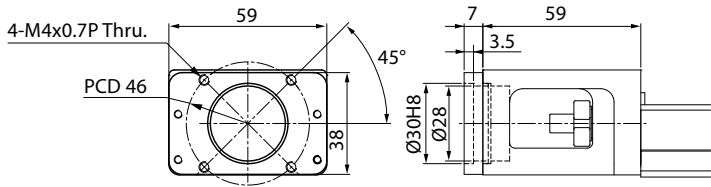

3D

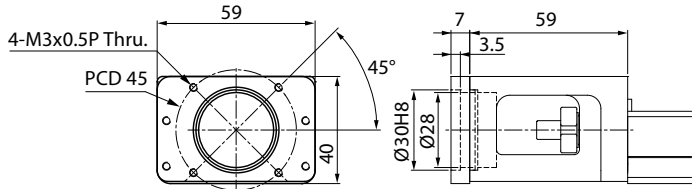

3H

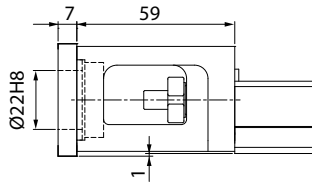
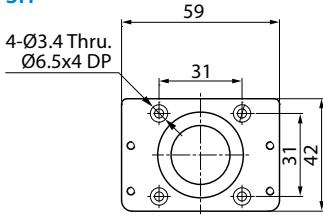

3I

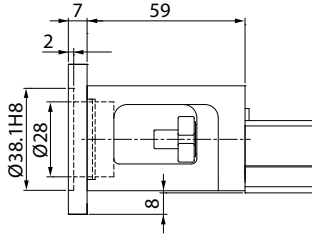
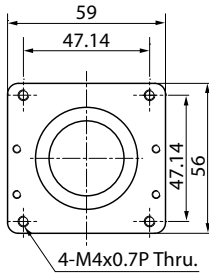

3J

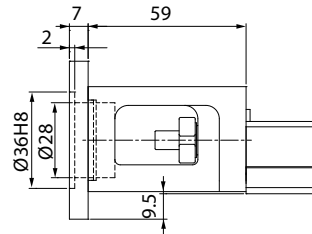
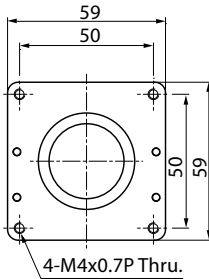

30

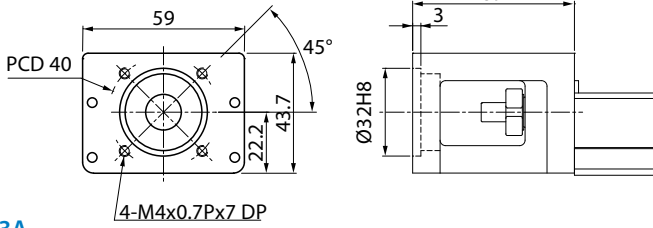

3A

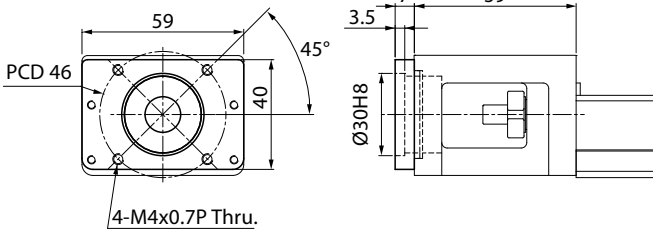

3D

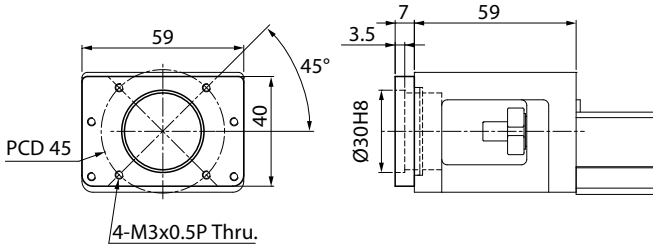



3H

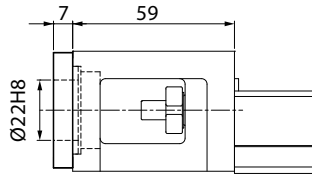
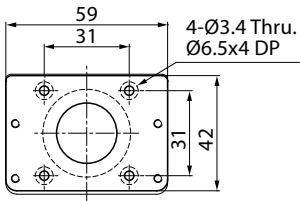

3I

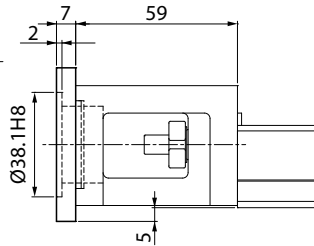
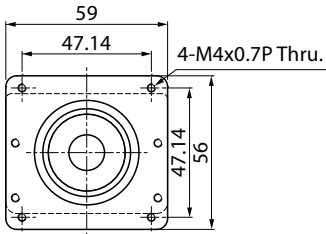

3J

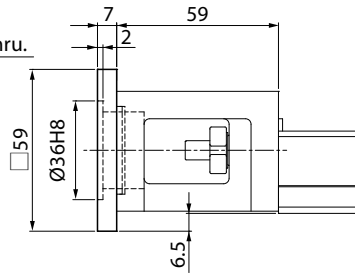
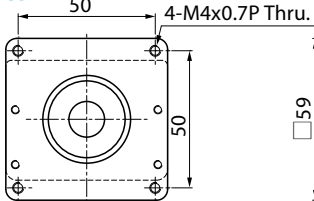

KM45

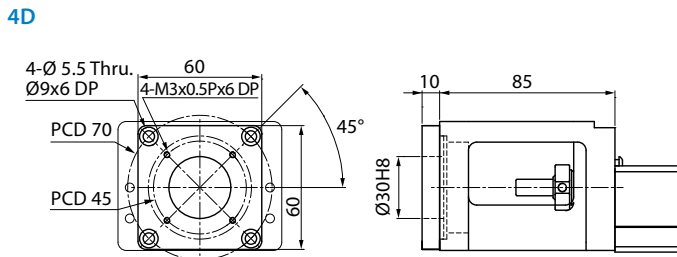
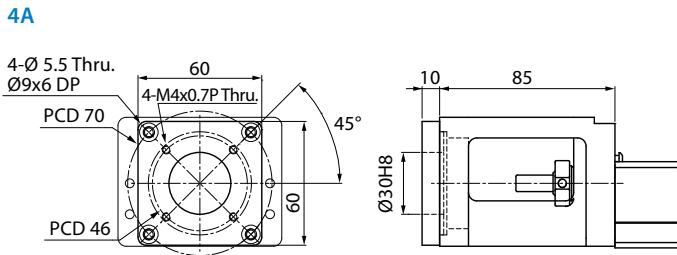
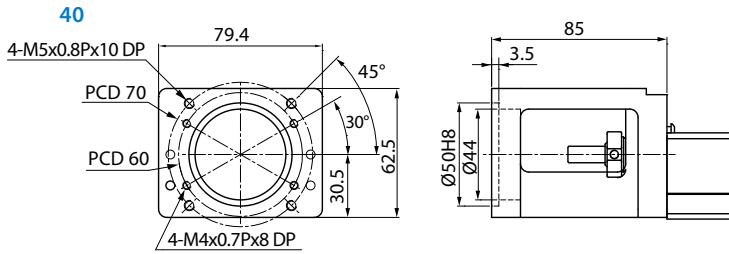

4H

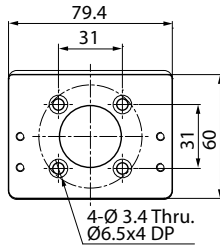

4I

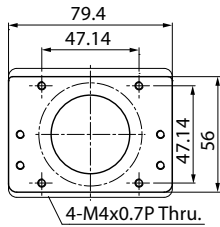

4J

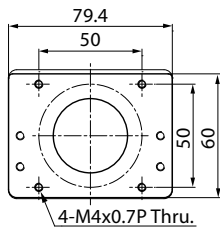

KM46

40

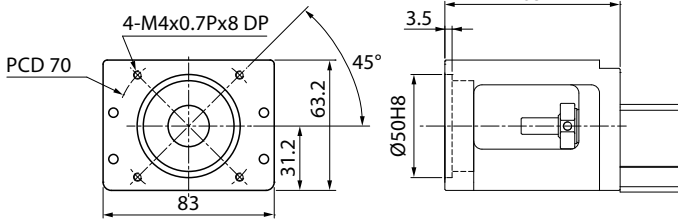

4A

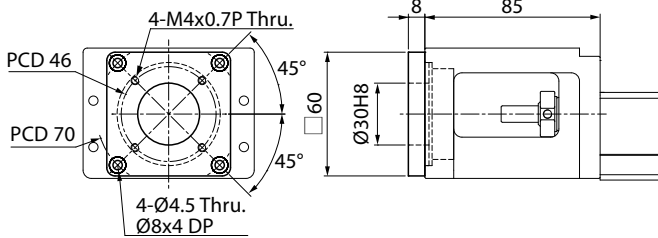

4D

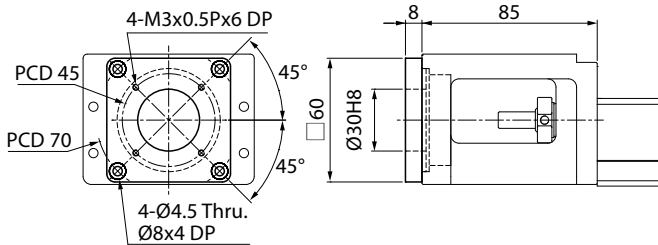

4H

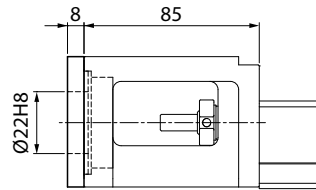
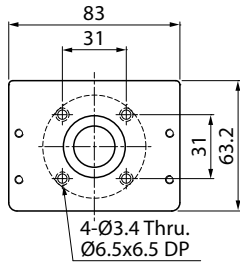

4I

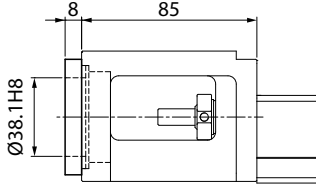
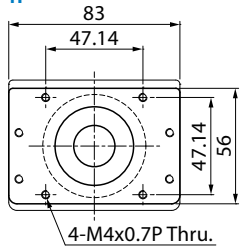

4J

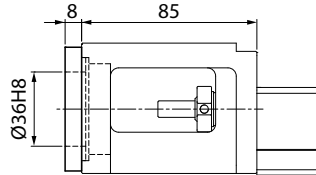
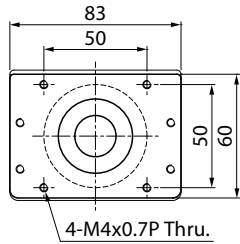

KM55

50

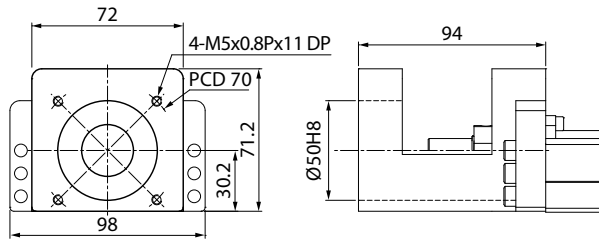

5C

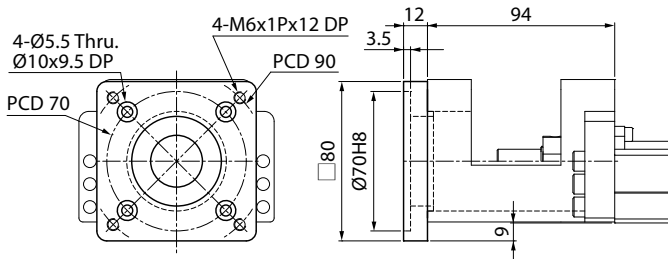

5F

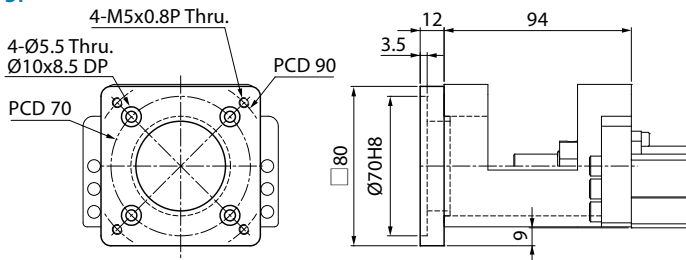

5K

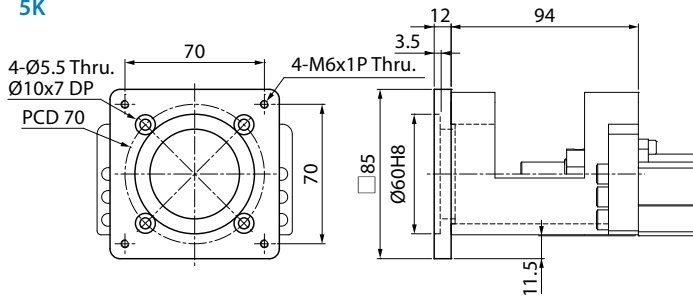

KM65

60

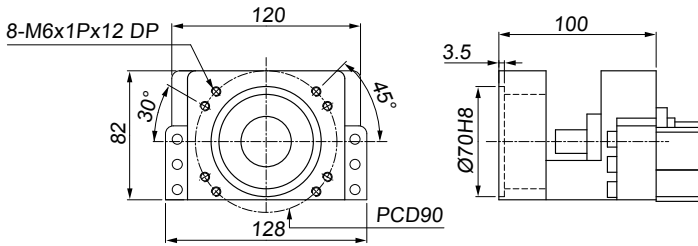

6C

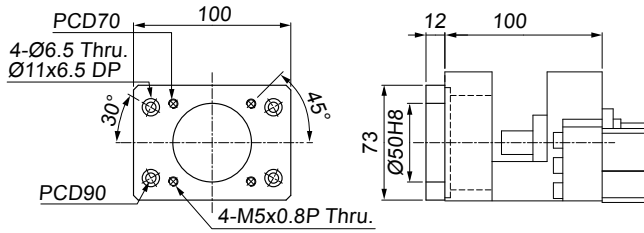

6K

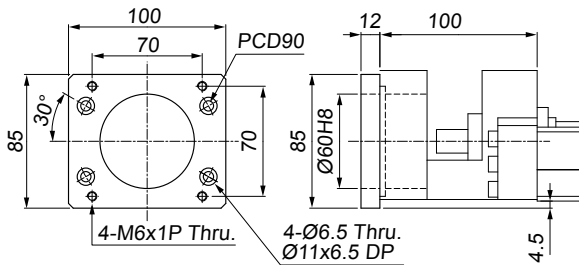



6F

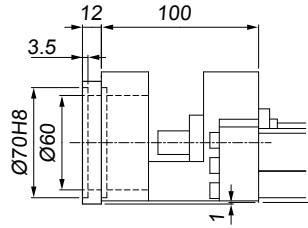
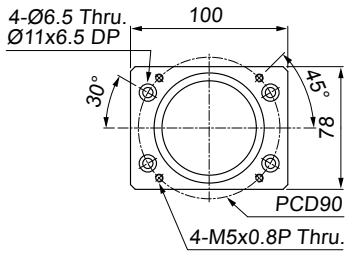

6G

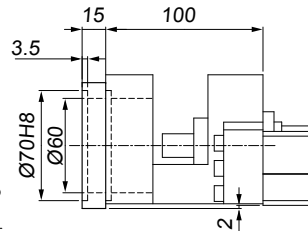
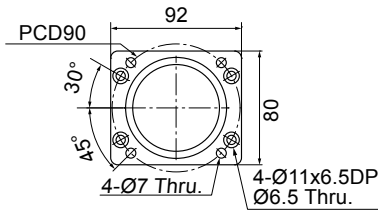





■ Mono Stage KM Series

---

# KM20 Standard Type

A type : A single carriage-nut with standard length

B type : Two carriage-nuts with standard length

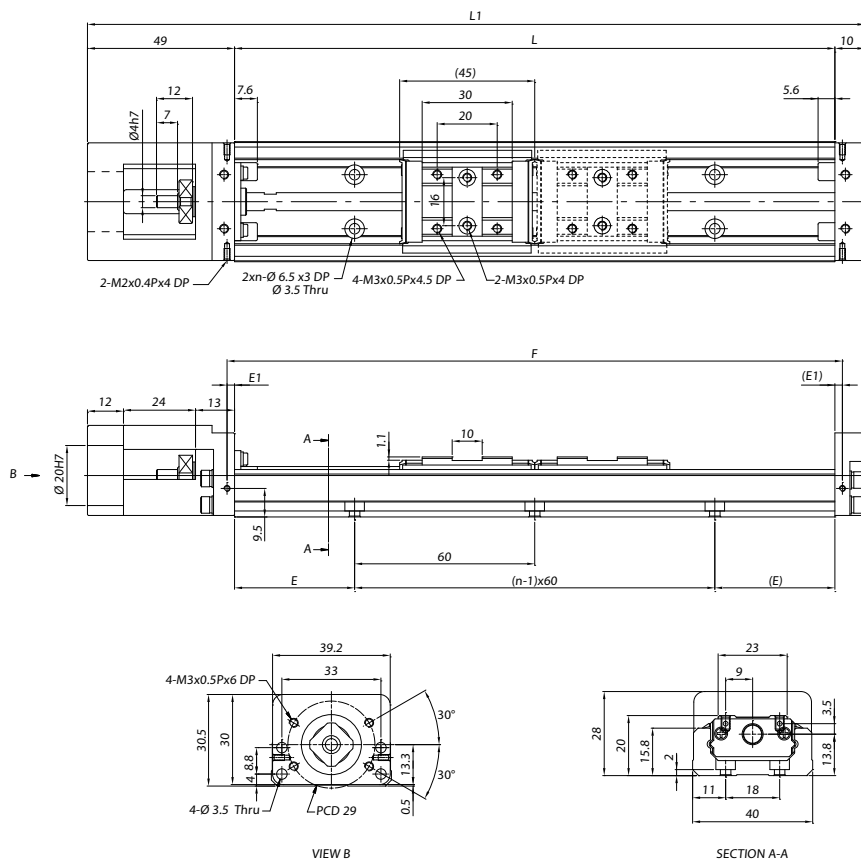

Unit : mm

Rail Length L	Overall Length L <sub>1</sub>	Max. Stroke		E	n	E1	F	Weight (kg)	
		A Type	B Type					A Type	B Type
100	159	41.8	-	20	2	2.5	105	0.473	-
150	209	91.8	46.8	15	3	2.5	155	0.593	0.693
200	259	141.8	96.8	40	3	2.5	205	0.713	0.813

Note\*: The max. stroke of B type is base on two carriage-nuts used in closed contact with each other.

A type : A single carriage-nut with standard length

B type : Two carriage-nuts with standard length

# KM20 Cover Type

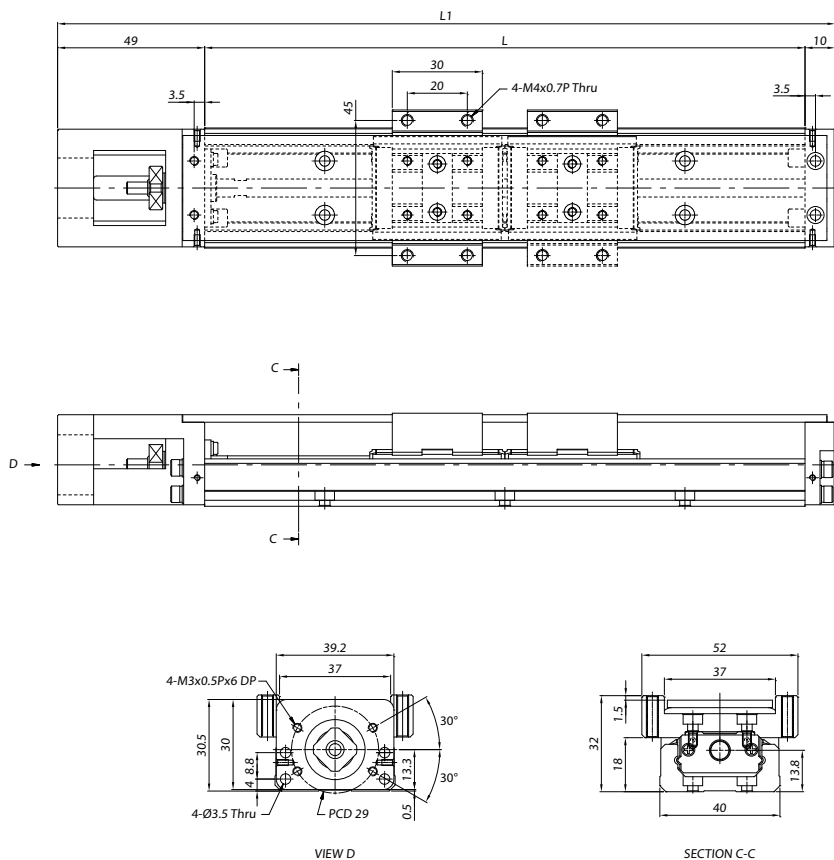

Unit : mm

Rail Length L	Overall Length L <sub>1</sub>	Max. Stroke		Weight (kg)	
		A Type	B Type	A Type	B Type
100	159	41.8	-	0.764	-
150	209	91.8	46.8	0.776	0.879
200	259	141.8	96.8	0.788	0.891

Note\*: The max. stroke of B type is base on two carriage-nuts used in closed contact with each other.

# KM26 Standard Type

A type : A single carriage-nut with standard length

B type : Two carriage-nuts with standard length

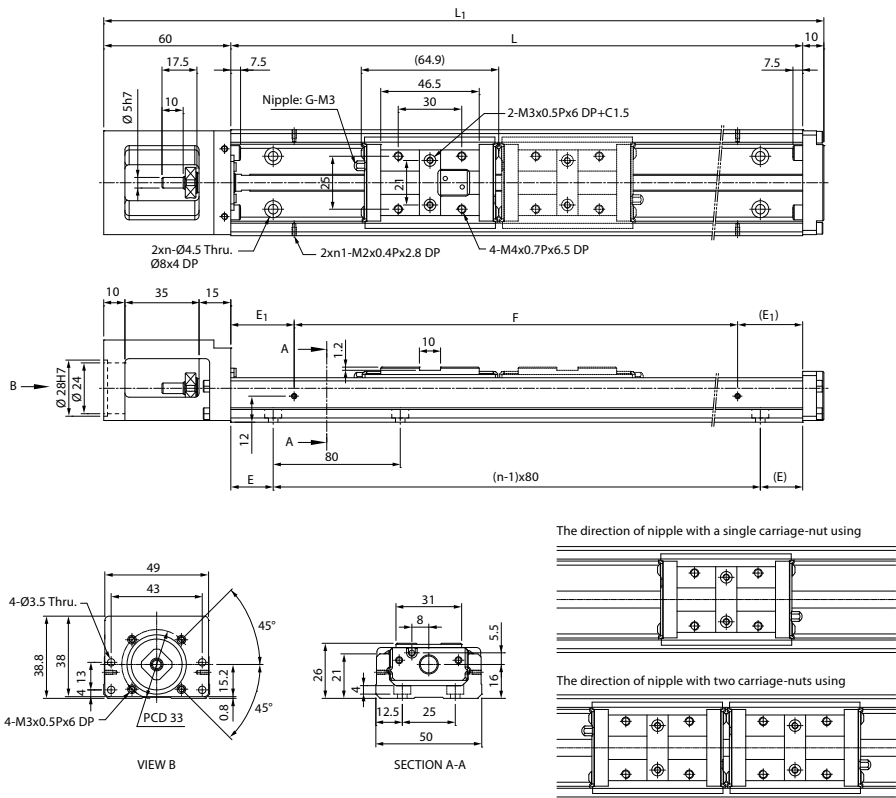

Unit : mm

Rail Length L	Overall Length L <sub>1</sub>	Max. Stroke		E	n	E <sub>1</sub>	n <sub>1</sub>	F	Weight (kg)	
		A Type	B Type						A Type	B Type
150	220	70	-	35	2	35	2	80	0.98	-
200	270	120	55	20	3	20	2	160	1.18	1.37
250	320	170	105	45	3	45	2	160	1.38	1.57
300	370	220	155	30	4	30	2	240	1.59	1.78

Note\*: The max. stroke of B type is base on two carriage-nuts used in closed contact with each other.

**A type** : A single carriage-nut with standard length

**B type** : Two carriage-nuts with standard length

# KM26 Cover Type

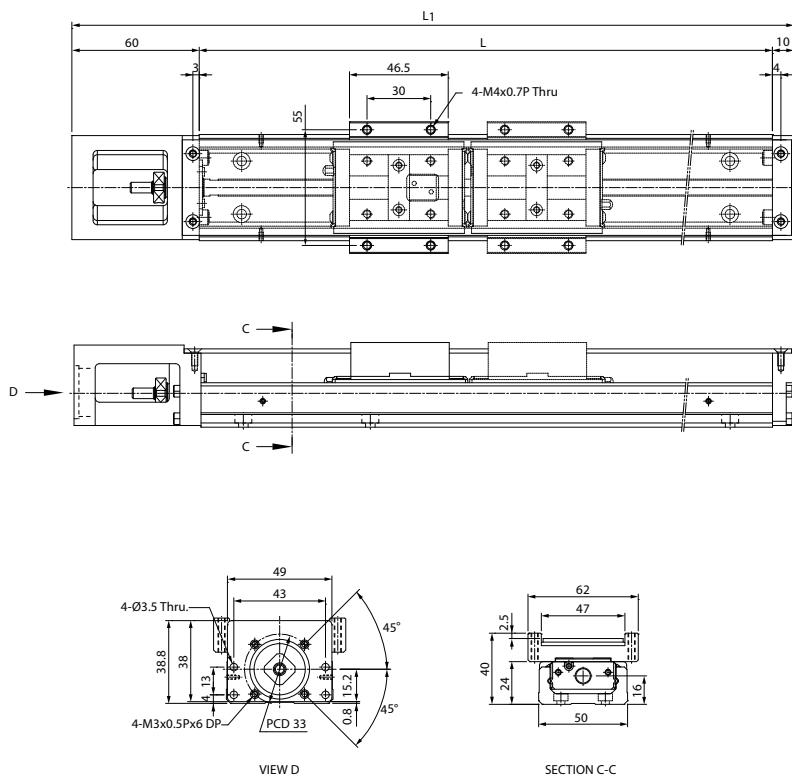

Unit : mm

Rail Length L	Overall Length L <sub>1</sub>	Max. Stroke		Weight (kg)	
		A Type	B Type	A Type	B Type
150	220	70	-	1.06	-
200	270	120	55	1.26	1.45
250	320	170	105	1.46	1.65
300	370	220	155	1.67	1.86

Note\*: The max. stroke of B type is base on two carriage-nuts used in closed contact with each other.

# KM30 Standard Type

A type : A single carriage-nut with standard length

B type : Two carriage-nuts with standard length

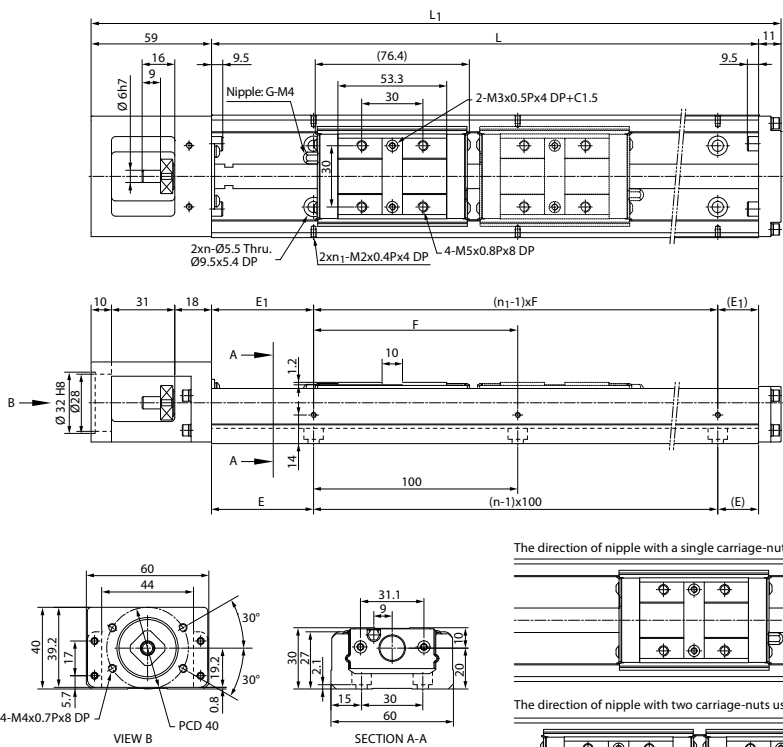

The direction of nipple with a single carriage-nut using

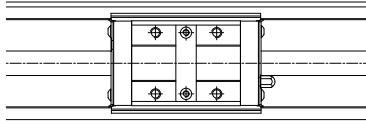

The direction of nipple with two carriage-nuts using

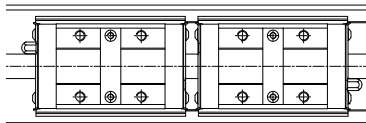

Unit : mm

Rail Length L	Overall Length L <sub>1</sub>	Max. Stroke		E	n	E <sub>1</sub>	n <sub>1</sub>	F	Weight (kg)	
		A Type	B Type						A Type	B Type
150	220	54.5	-	25	2	25	2	100	1.5	-
200	270	104.5	-	50	2	50	2	100	1.81	-
300	370	204.5	128	50	3	50	2	200	2.39	2.74
400	470	304.5	228	50	4	100	2	200	2.98	3.33
500	570	404.5	328	50	5	50	3	200	3.68	4.03
600	670	504.5	428	50	6	100	3	200	4.29	4.64

Note\*: The max. stroke of B type is base on two carriage-nuts used in closed contact with each other.



**A type** : A single carriage-nut with standard length

**B type** : Two carriage-nuts with standard length

# KM30 Cover Type

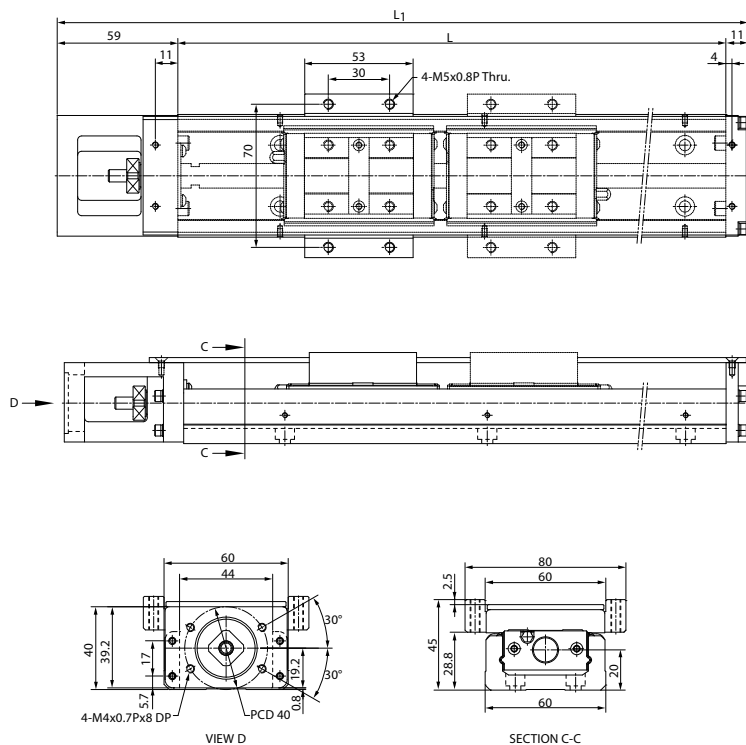

Unit : mm

Rail Length L	Overall Length L <sub>1</sub>	Max. Stroke		Weight (kg)	
		A Type	B Type	A Type	B Type
150	220	54.5	-	1.7	-
200	270	104.5	-	2.01	-
300	370	204.5	128	2.59	3.04
400	470	304.5	228	3.21	3.66
500	570	404.5	328	3.92	4.37
600	670	504.5	428	4.54	4.99

Note\*: The max. stroke of B type is base on two carriage-nuts used in closed contact with each other.

# KM30 Standard Type

C type : A single carriage-nut with short length

D type : Two carriage-nuts with short length

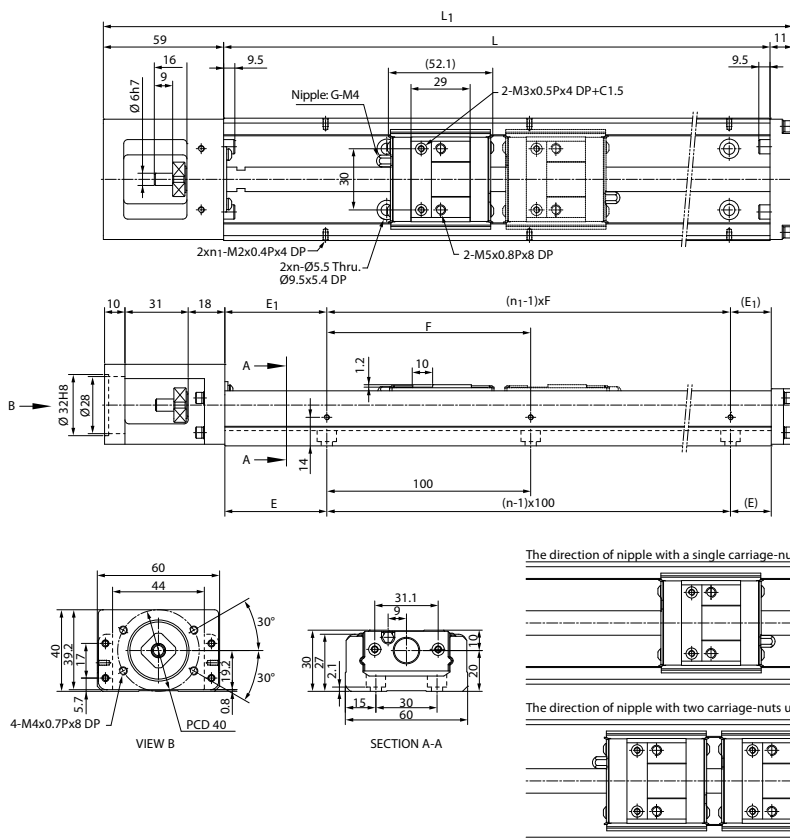

Unit : mm

Rail Length L	Overall Length L <sub>1</sub>	Max. Stroke		E	n	E <sub>1</sub>	n <sub>1</sub>	F	Weight (kg)	
		C Type	D Type						C Type	D Type
150	220	78.8	26.6	25	2	25	2	100	1.4	1.63
200	270	128.8	76.6	50	2	50	2	100	1.69	1.92
300	370	228.8	176.6	50	3	50	2	200	2.28	2.51
400	470	328.8	276.6	50	4	100	2	200	2.88	3.11
500	570	428.8	376.6	50	5	50	3	200	3.56	3.79
600	670	528.8	476.6	50	6	100	3	200	4.17	4.4

Note\*: The max. stroke of D type is base on two carriage-nuts used in closed contact with each other.

**C type** : A single carriage-nut with short length

**D type** : Two carriage-nuts with short length

# KM30 Cover Type

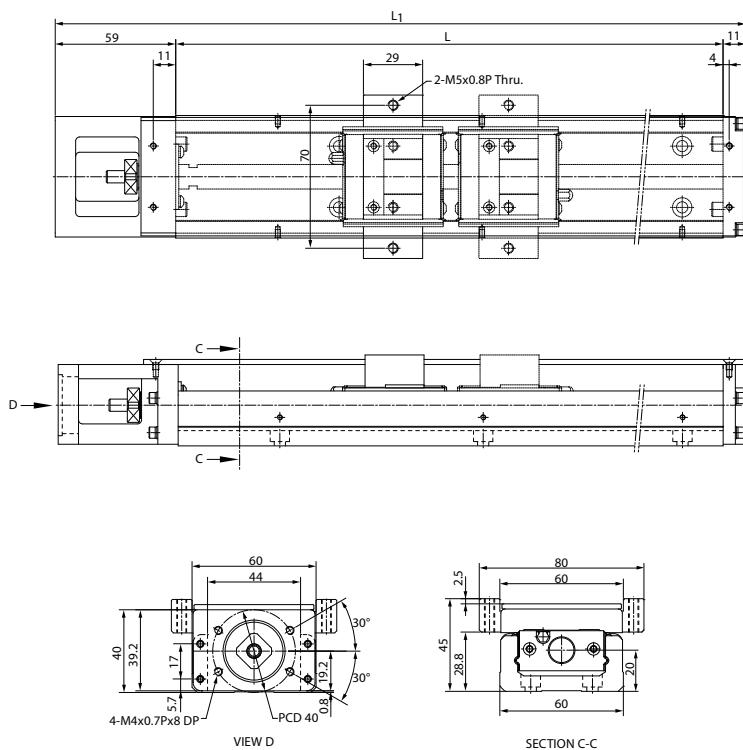

Unit : mm

Rail Length L	Overall Length L <sub>1</sub>	Max. Stroke		Weight (kg)	
		C Type	D Type	C Type	D Type
150	220	78.8	26.6	1.51	1.76
200	270	128.8	76.6	1.82	2.07
300	370	228.8	176.6	2.45	2.70
400	470	328.8	276.6	3.09	3.34
500	570	428.8	376.6	3.82	4.07
600	670	528.8	476.6	4.47	4.72

Note\*: The max. stroke of D type is base on two carriage-nuts used in closed contact with each other.

# KM33 Standard Type

A type : A single carriage-nut with standard length

B type : Two carriage-nuts with standard length

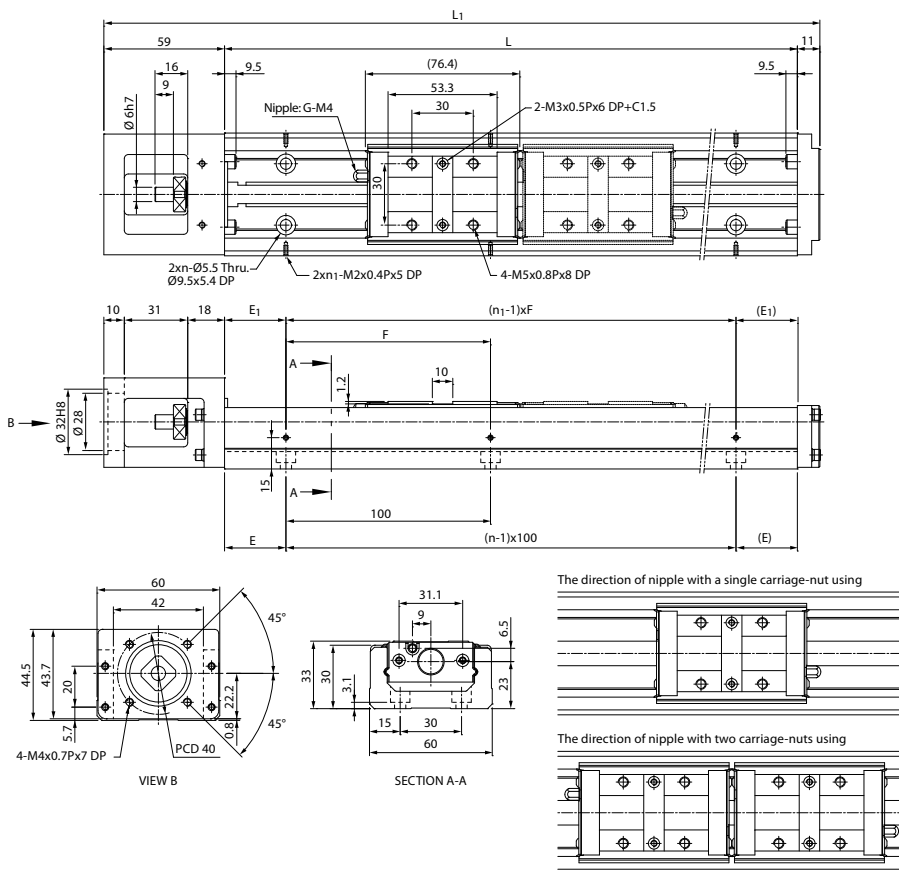

Unit : mm

Rail Length L	Overall Length L <sub>1</sub>	Max. Stroke		E	n	E <sub>1</sub>	n <sub>1</sub>	F	Weight (kg)	
		A Type	B Type						A Type	B Type
150	220	54.5	-	25	2	25	2	100	1.67	-
200	270	104.5	-	50	2	50	2	100	1.98	-
300	370	204.5	128	50	3	50	2	200	2.56	2.91
400	470	304.5	228	50	4	100	2	200	3.15	3.5
500	570	404.5	328	50	5	50	3	200	3.85	4.2
600	670	504.5	428	50	6	100	3	200	4.46	4.81

Note\*: The max. stroke of B type is base on two carriage-nuts used in closed contact with each other.

A type : A single carriage-nut with standard length

B type : Two carriage-nuts with standard length

# KM33 Cover Type

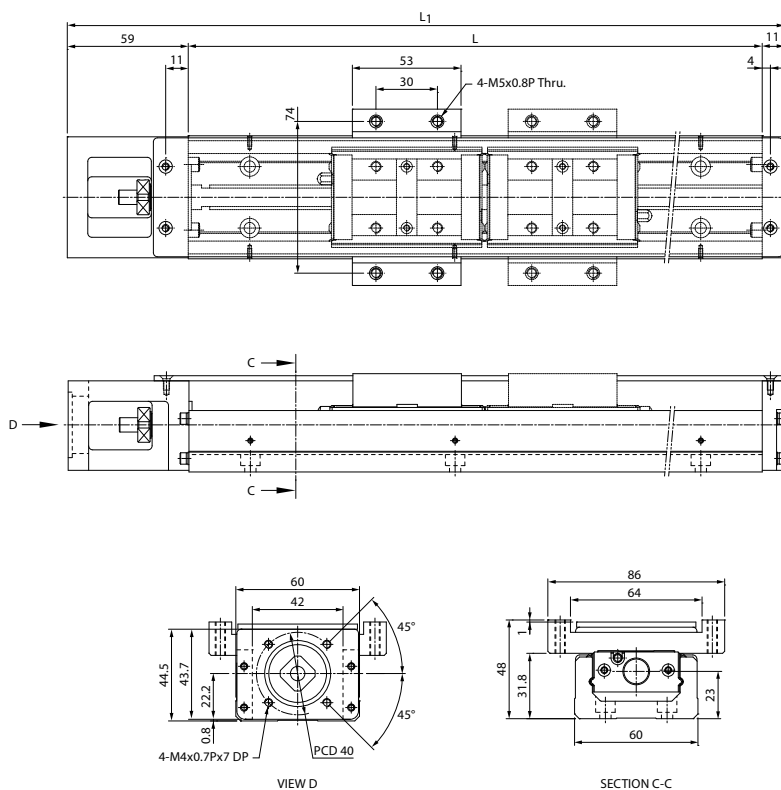

Unit : mm

Rail Length L	Overall Length L <sub>1</sub>	Max. Stroke		Weight (kg)	
		A Type	B Type	A Type	B Type
150	220	54.5	-	1.87	-
200	270	104.5	-	2.18	-
300	370	204.5	128	2.76	3.21
400	470	304.5	228	3.38	3.83
500	570	404.5	328	4.09	4.54
600	670	504.5	428	4.71	5.16

Note\*: The max. stroke of B type is base on two carriage-nuts used in closed contact with each other.

# KM33 Standard Type

C type : A single carriage-nut with short length

D type : Two carriage-nuts with short length

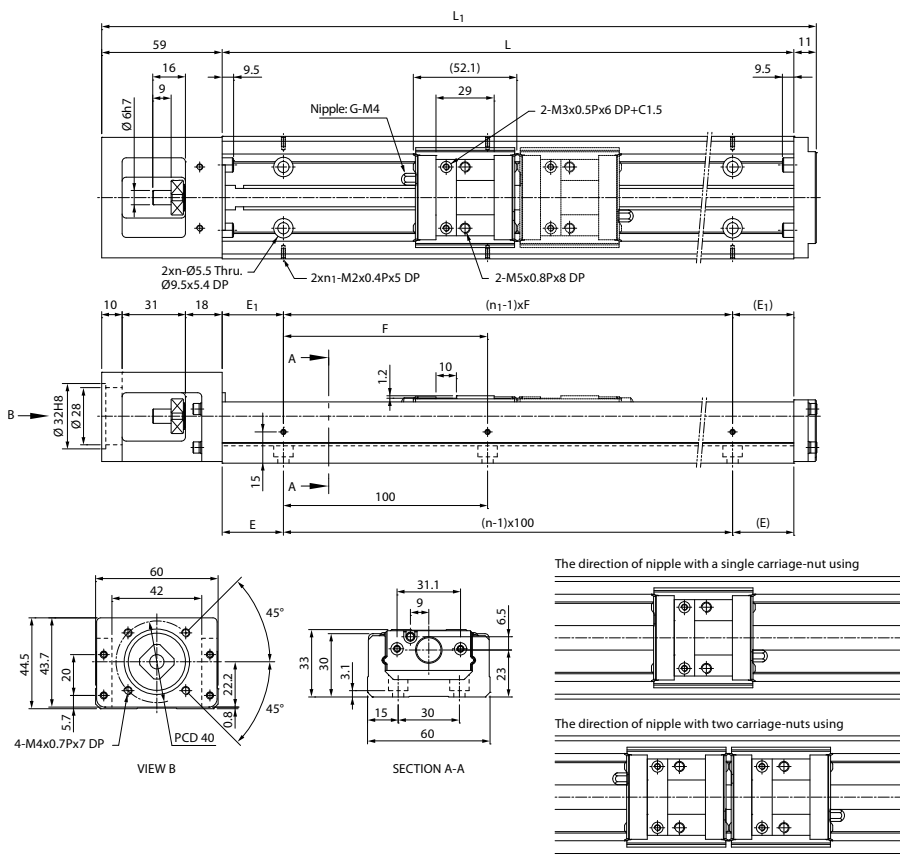

Unit : mm

Rail Length L	Overall Length L <sub>1</sub>	Max. Stroke		E	n	E <sub>1</sub>	n <sub>1</sub>	F	Weight (kg)	
		C Type	D Type						C Type	D Type
150	220	78.8	26.6	25	2	25	2	100	1.57	1.8
200	270	128.8	76.6	50	2	50	2	100	1.86	2.09
300	370	228.8	176.6	50	3	50	2	200	2.45	2.68
400	470	328.8	276.6	50	4	100	2	200	3.05	3.28
500	570	428.8	376.6	50	5	50	3	200	3.73	3.96
600	670	528.8	476.6	50	6	100	3	200	4.34	4.57

Note\*: The max. stroke of D type is base on two carriage-nuts used in closed contact with each other.

C type : A single carriage-nut with short length

D type : Two carriage-nuts with short length

# KM33 Cover Type

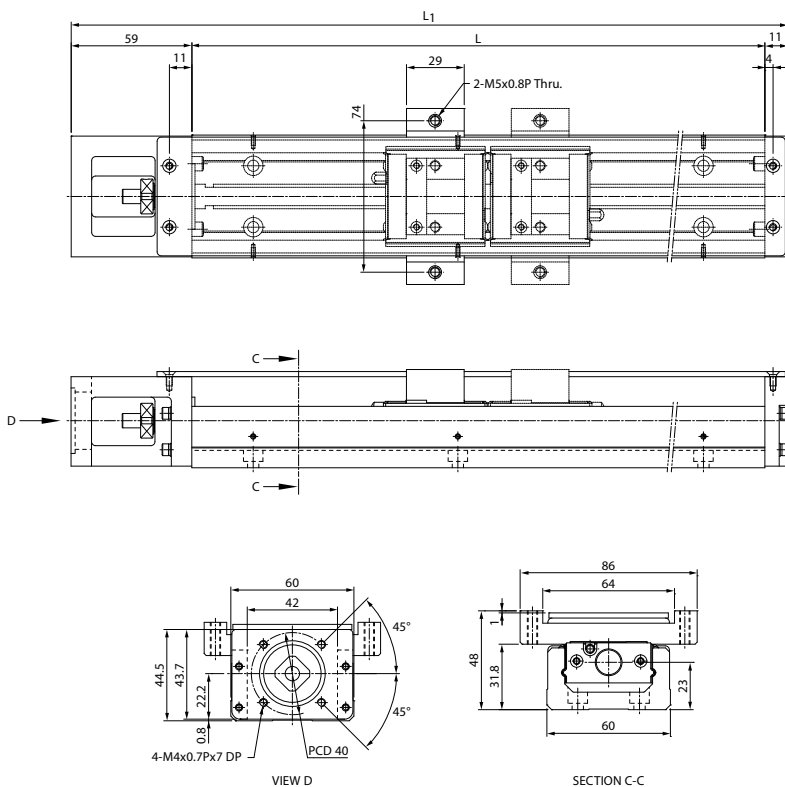

Unit : mm

Rail Length L	Overall Length L <sub>1</sub>	Max. Stroke		Weight (kg)	
		C Type	D Type	C Type	D Type
150	220	78.8	26.6	1.68	1.93
200	270	128.8	76.6	1.99	2.24
300	370	228.8	176.6	2.62	2.87
400	470	328.8	276.6	3.26	3.51
500	570	428.8	376.6	3.99	4.24
600	670	528.8	476.6	4.64	4.89

Note\*: The max. stroke of D type is base on two carriage-nuts used in closed contact with each other.

# KM45 Standard Type

A type : A single carriage-nut with standard length

B type : Two carriage-nuts with standard length

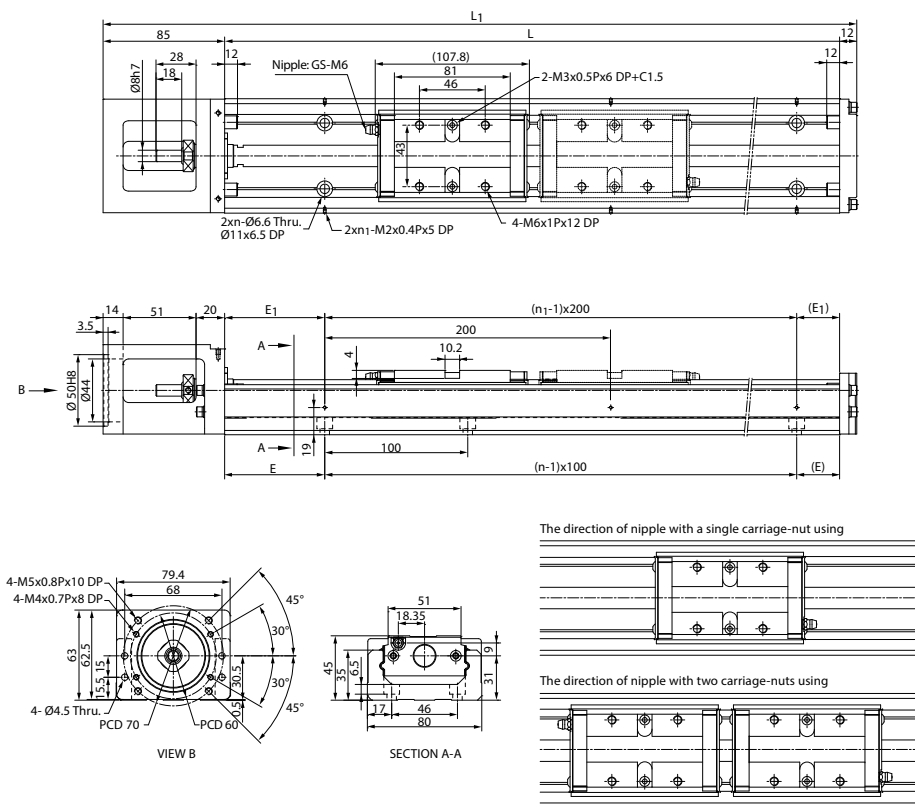

Unit : mm

Rail Length L	Overall Length L <sub>1</sub>	Max. Stroke		E	n	E <sub>1</sub>	n <sub>1</sub>	Weight (kg)	
		A Type	B Type					A Type	B Type
340	437	208.2	100.4	70	3	70	2	6.78	7.98
440	537	308.2	200.4	70	4	20	3	8.07	9.27
540	637	408.2	300.4	70	5	70	3	9.37	10.57
640	737	508.2	400.4	70	6	20	4	10.68	11.88
740	837	608.2	500.4	70	7	70	4	12.08	13.28
840	937	708.2	600.4	70	8	20	5	13.2	14.4
940	1037	808.2	700.4	70	9	70	5	14.37	15.57

Note\*: The max. stroke of B type is base on two carriage-nuts used in closed contact with each other.



**A type** : A single carriage-nut with standard length

**B type** : Two carriage-nuts with standard length

# KM45 Cover Type

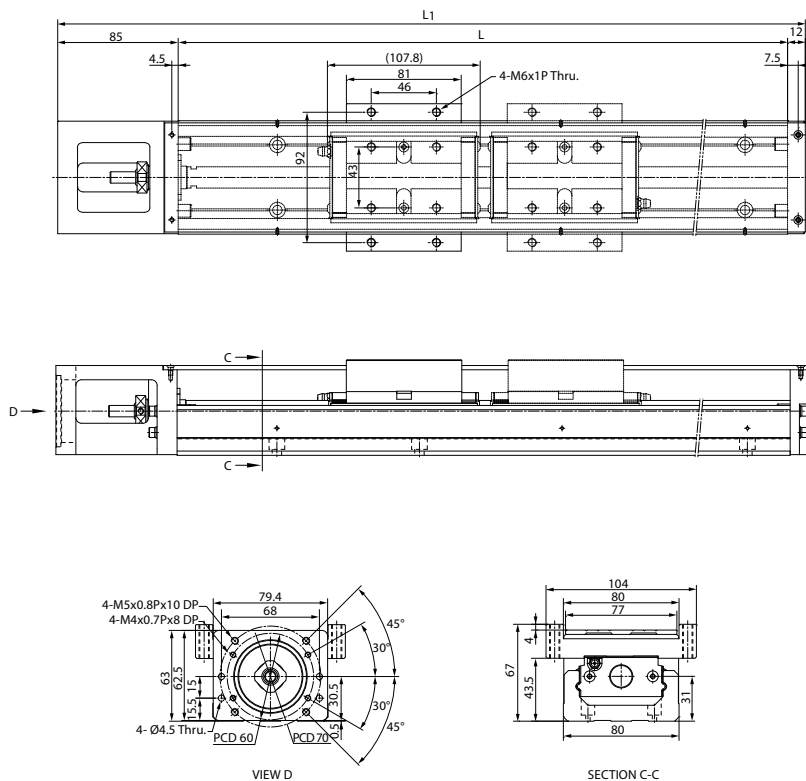

Unit : mm

Rail Length L	Overall Length L <sub>1</sub>	Max. Stroke		Weight (kg)	
		A Type	B Type	A Type	B Type
340	437	208.2	100.4	7.38	8.78
440	537	308.2	200.4	8.67	10.07
540	637	408.2	300.4	9.97	11.37
640	737	508.2	400.4	11.28	12.68
740	837	608.2	500.4	12.68	14.08
840	937	708.2	600.4	13.78	15.18
940	1037	808.2	700.4	14.97	16.37

Note\*: The max. stroke of B type is base on two carriage-nuts used in closed contact with each other.

# KM45 Standard Type

C type : A single carriage-nut with short length

D type : Two carriage-nuts with short length

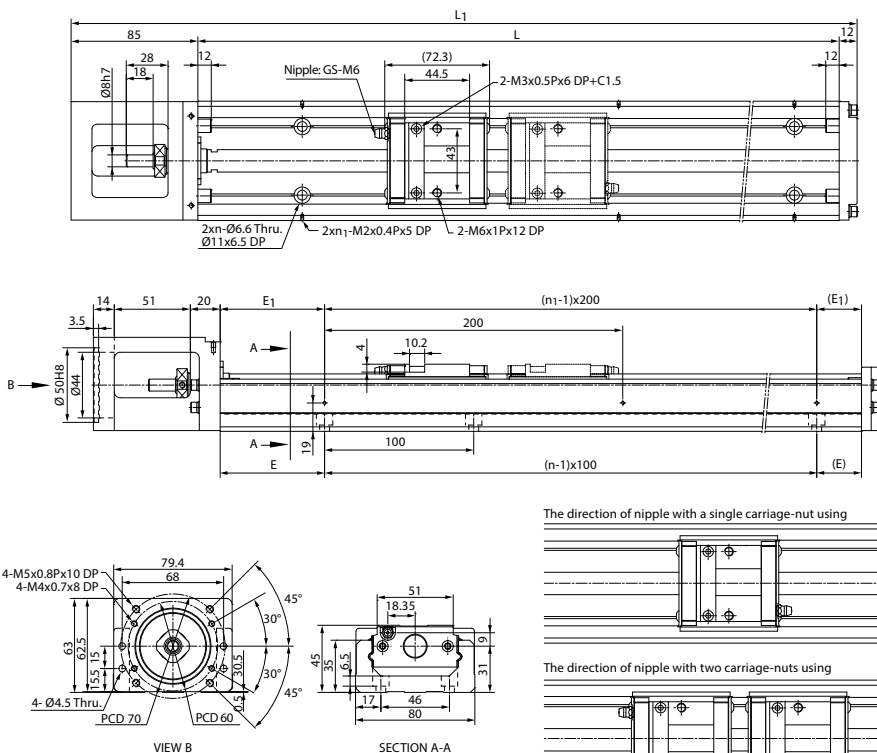

The direction of nipple with a single carriage-nut using

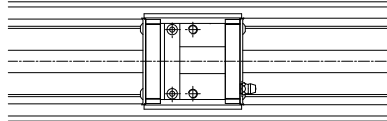

The direction of nipple with two carriage-nuts using

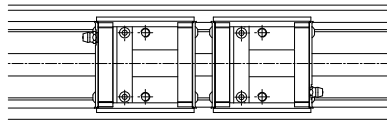

Unit : mm

Rail Length $L$	Overall Length $L_1$	Max. Stroke		$E$	$n$	$E_1$	$n_1$	Weight (kg)	
		C Type	D Type					C Type	D Type
340	437	244.7	173.4	70	3	70	2	6.38	7.18
440	537	344.7	273.4	70	4	20	3	7.67	8.47
540	637	444.7	373.4	70	5	70	3	8.97	9.77
640	737	544.7	473.4	70	6	20	4	10.28	11.08
740	837	644.7	573.4	70	7	70	4	11.68	12.48
840	937	744.7	673.4	70	8	20	5	12.78	13.58
940	1037	844.7	773.4	70	9	70	5	13.97	14.77

Note\*: The max. stroke of D type is base on two carriage-nuts used in closed contact with each other.

C type : A single carriage-nut with short length

D type : Two carriage-nuts with short length

# KM45 Cover Type

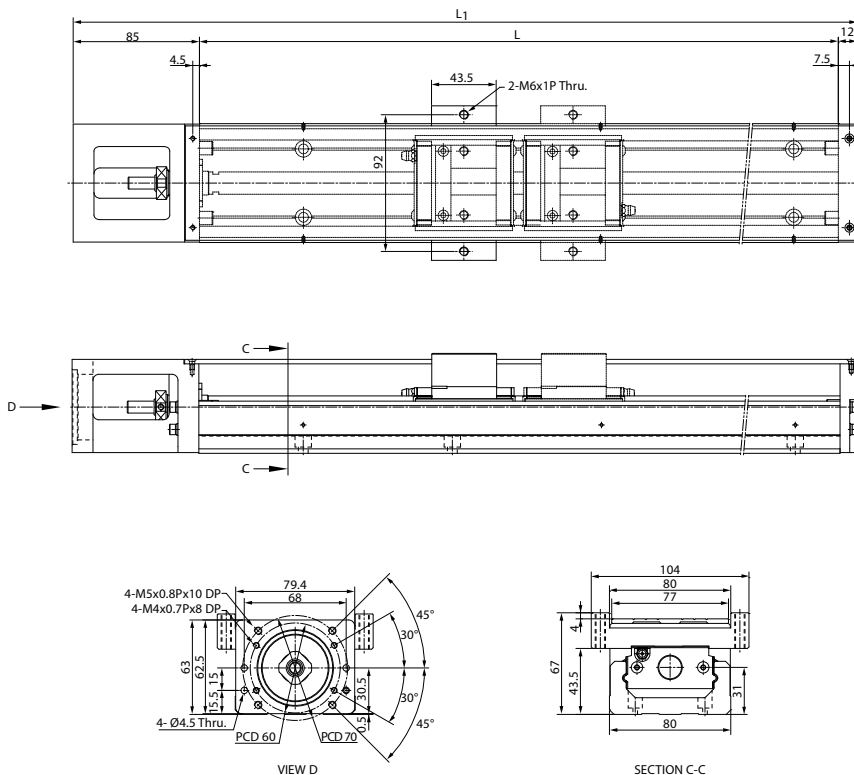

Unit : mm

Rail Length L	Overall Length L <sub>1</sub>	Max. Stroke		Weight (kg)	
		C Type	D Type	C Type	D Type
340	437	244.7	173.4	6.58	7.58
440	537	344.7	273.4	7.87	8.87
540	637	444.7	373.4	9.17	10.17
640	737	544.7	473.4	10.48	11.48
740	837	644.7	573.4	11.88	12.88
840	937	744.7	673.4	12.98	13.98
940	1037	844.7	773.4	14.17	15.17

Note\*: The max. stroke of D type is base on two carriage-nuts used in closed contact with each other.

# KM46 Standard Type

A type : A single carriage-nut with standard length

B type : Two carriage-nuts with standard length

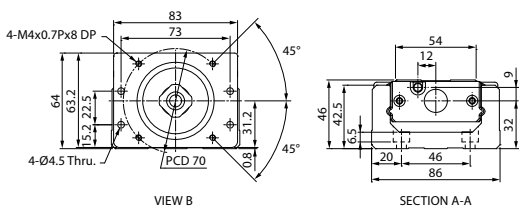
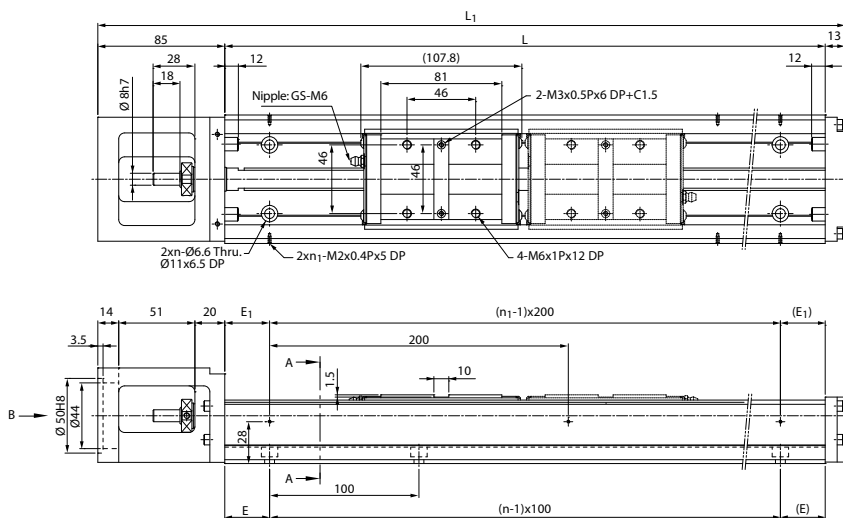

The direction of nipple with a single carriage-nut using

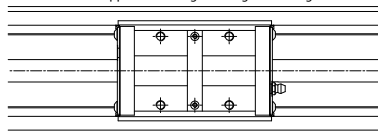

The direction of nipple with two carriage-nuts using

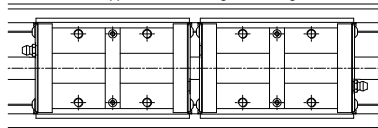

Unit : mm

Rail Length L	Overall Length L <sub>1</sub>	Max. Stroke		E	n	E <sub>1</sub>	n <sub>1</sub>	Weight (kg)	
		A Type	B Type					A Type	B Type
		340	438					208.2	100.4
440	538	308.2	200.4	70	4	20	3	8.94	10.14
540	638	408.2	300.4	70	5	70	3	10.24	11.44
640	738	508.2	400.4	70	6	20	4	11.55	12.75
740	838	608.2	500.4	70	7	70	4	12.95	14.15
840	938	708.2	600.4	70	8	20	5	14.1	15.3
940	1038	808.2	700.4	70	9	70	5	15.24	16.44

Note\*: The max. stroke of B type is base on two carriage-nuts used in closed contact with each other.

**A type** : A single carriage-nut with standard length

**B type** : Two carriage-nuts with standard length

# KM46 Cover Type

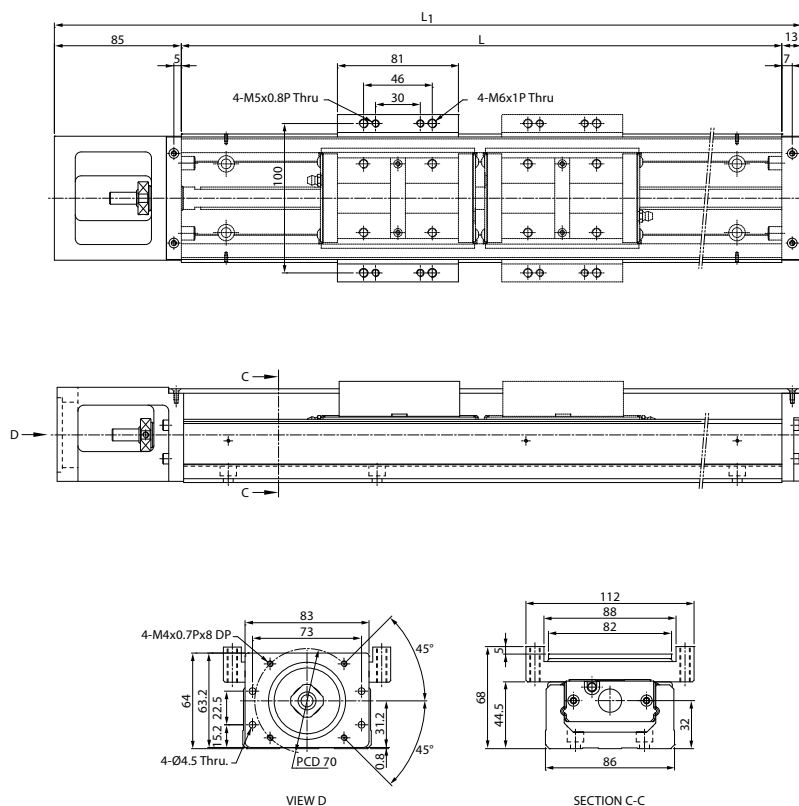

Unit : mm

Rail Length L	Overall Length L <sub>1</sub>	Max. Stroke		Weight (kg)	
		A Type	B Type	A Type	B Type
340	438	208.2	100.4	8.25	9.65
440	538	308.2	200.4	9.54	10.94
540	638	408.2	300.4	10.84	12.24
640	738	508.2	400.4	12.15	13.55
740	838	608.2	500.4	13.55	14.95
840	938	708.2	600.4	14.65	16.05
940	1038	808.2	700.4	15.84	17.24

Note\*: The max. stroke of B type is base on two carriage-nuts used in closed contact with each other.

# KM46 Standard Type

C type : A single carriage-nut with short length

D type : Two carriage-nuts with short length

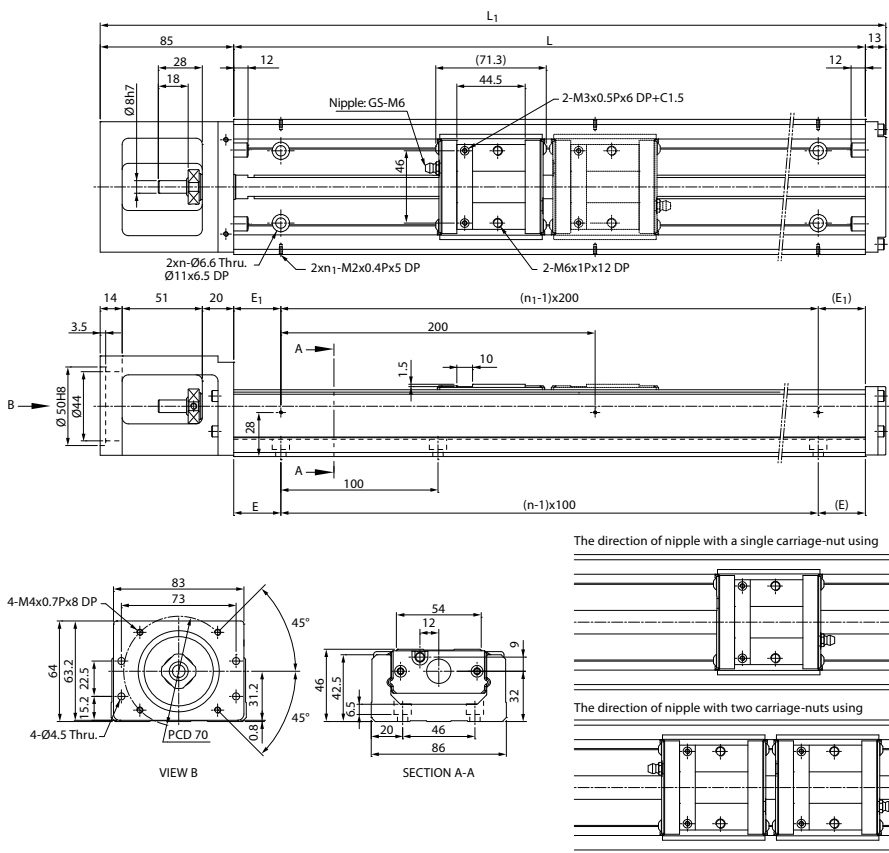

Unit : mm

Rail Length L	Overall Length L <sub>1</sub>	Max. Stroke		E	n	E <sub>1</sub>	n <sub>1</sub>	Weight (kg)	
		C Type	D Type					C Type	D Type
340	438	244.7	173.4	70	3	70	2	7.25	8.05
440	538	344.7	273.4	70	4	20	3	8.54	9.34
540	638	444.7	373.4	70	5	70	3	9.84	10.64
640	738	544.7	473.4	70	6	20	4	11.15	11.95
740	838	644.7	573.4	70	7	70	4	12.55	13.35
840	938	744.7	673.4	70	8	20	5	13.65	14.45
940	1038	844.7	773.4	70	9	70	5	14.84	15.64

Note\*: The max. stroke of D type is base on two carriage-nuts used in closed contact with each other.

C type : A single carriage-nut with short length

D type : Two carriage-nuts with short length

# KM46 Cover Type

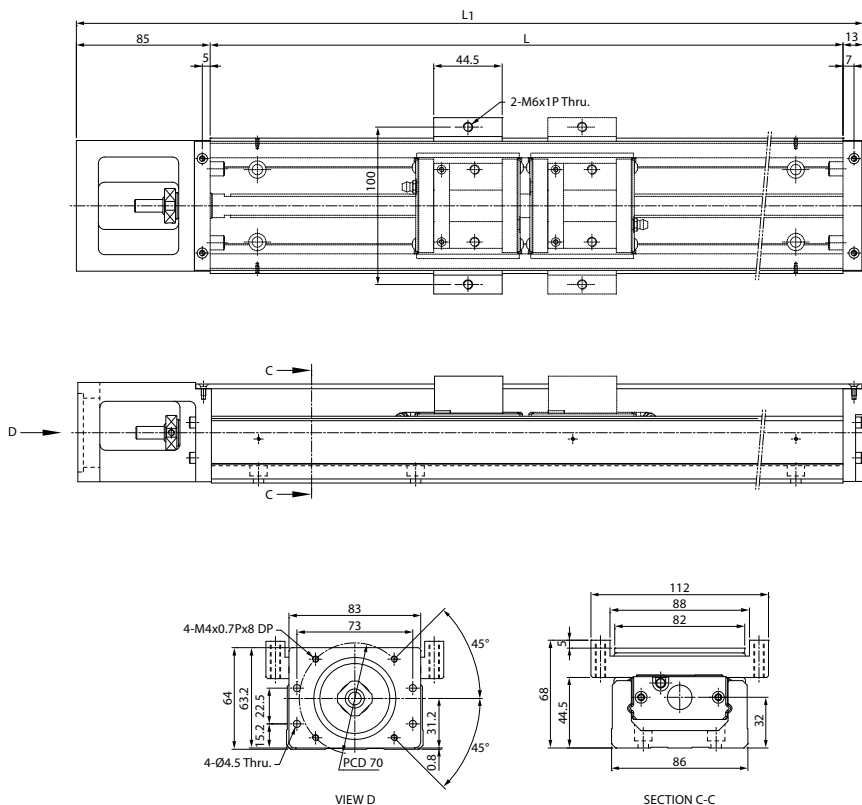

Unit : mm

Rail Length L	Overall Length L <sub>1</sub>	Max. Stroke		Weight (kg)	
		C Type	D Type	C Type	D Type
340	438	244.7	173.4	7.45	8.45
440	538	344.7	273.4	8.74	9.74
540	638	444.7	373.4	10.04	11.04
640	738	544.7	473.4	11.35	12.35
740	838	644.7	573.4	12.75	13.75
840	938	744.7	673.4	13.85	14.85
940	1038	844.7	773.4	15.04	16.04

Note\*: The max. stroke of D type is base on two carriage-nuts used in closed contact with each other.

# KM55 Standard Type

A type : A single carriage-nut with standard length

B type : Two carriage-nuts with standard length

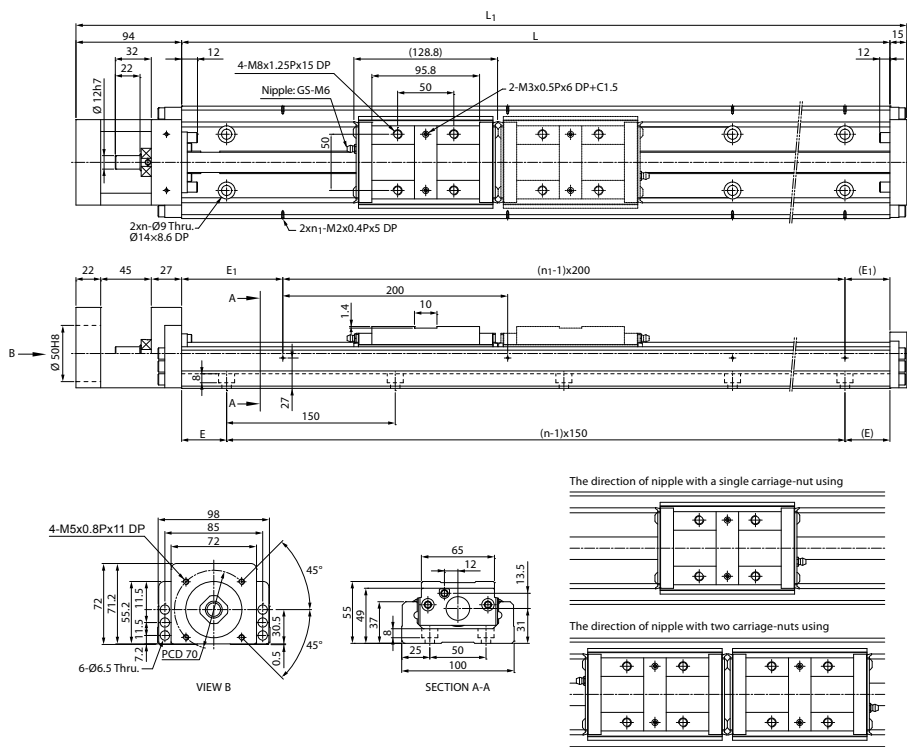

Unit : mm

Rail Length L	Overall Length L <sub>1</sub>	Max. Stroke		E	n	E <sub>1</sub>	n <sub>1</sub>	Weight (kg)	
		A Type	B Type					A Type	B Type
980	1089	828	699	40	7	90	5	19.90	21.62
1080	1189	928	799	15	8	40	6	21.63	23.35
1180	1289	1028	899	65	8	90	6	23.36	25.08
1280	1389	1128	999	40	9	40	7	25.09	26.81
1380	1489	1228	1099	15	10	90	7	26.82	28.54

Note\*: The max. stroke of B type is base on two carriage-nuts used in closed contact with each other.



A type : A single carriage-nut with standard length

B type : Two carriage-nuts with standard length

# KM55 Cover Type

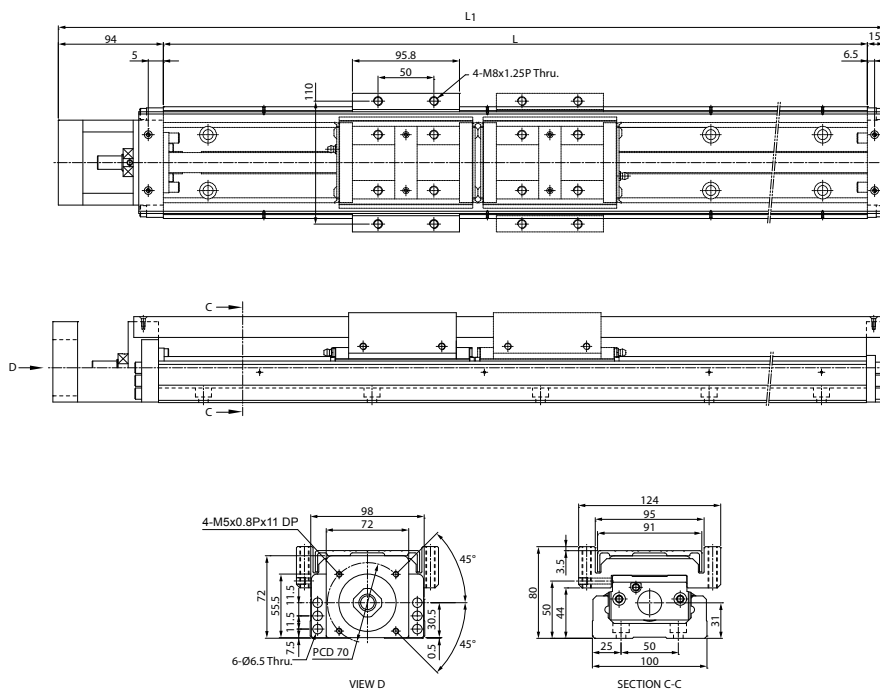

Unit : mm

Rail Length L	Overall Length L <sub>1</sub>	Max. Stroke		Weight (kg)	
		A Type	B Type	A Type	B Type
980	1089	828	699	21.78	24.25
1080	1189	928	799	23.61	26.08
1180	1289	1028	899	25.44	27.91
1280	1389	1128	999	27.26	29.73
1380	1489	1228	1099	29.09	31.56

Note\*: The max. stroke of B type is base on two carriage-nuts used in closed contact with each other.

# KM65 Standard Type

A type : A single carriage-nut with standard length

B type : Two carriage-nuts with standard length

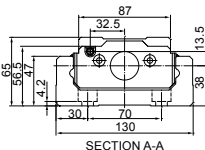
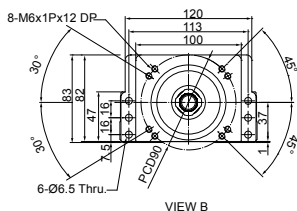
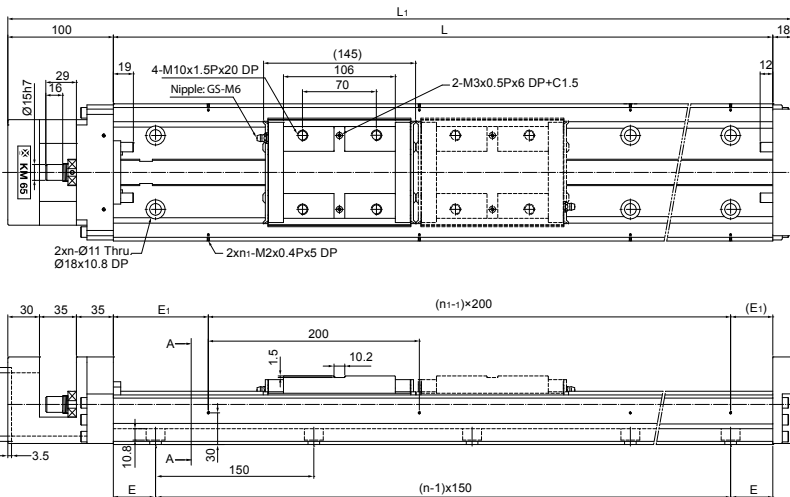

The direction of nipple with a single carriage-nut using

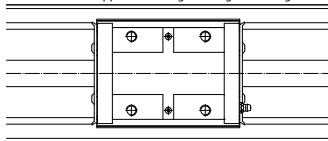

The direction of nipple with two carriage-nuts using

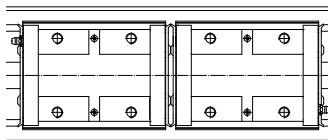

Unit : mm

Rail Length L	Overall Length L <sub>1</sub>	Max. Stroke		E	n	E <sub>1</sub>	n <sub>1</sub>	Weight (kg)	
		A Type	B Type					A Type	B Type
980	1098	800	655	40	7	90	5	31.60	34.60
1180	1298	1000	855	65	8	90	6	37.00	40.00
1380	1498	1200	1055	90	9	90	7	42.40	45.40
1680	1798	1500	1355	90	11	40	9	50.50	53.50

Note\*: The max. stroke of B type is base on two carriage-nuts used in closed contact with each other.

A type : A single carriage-nut with standard length

B type : Two carriage-nuts with standard length

# KM65 Cover Type

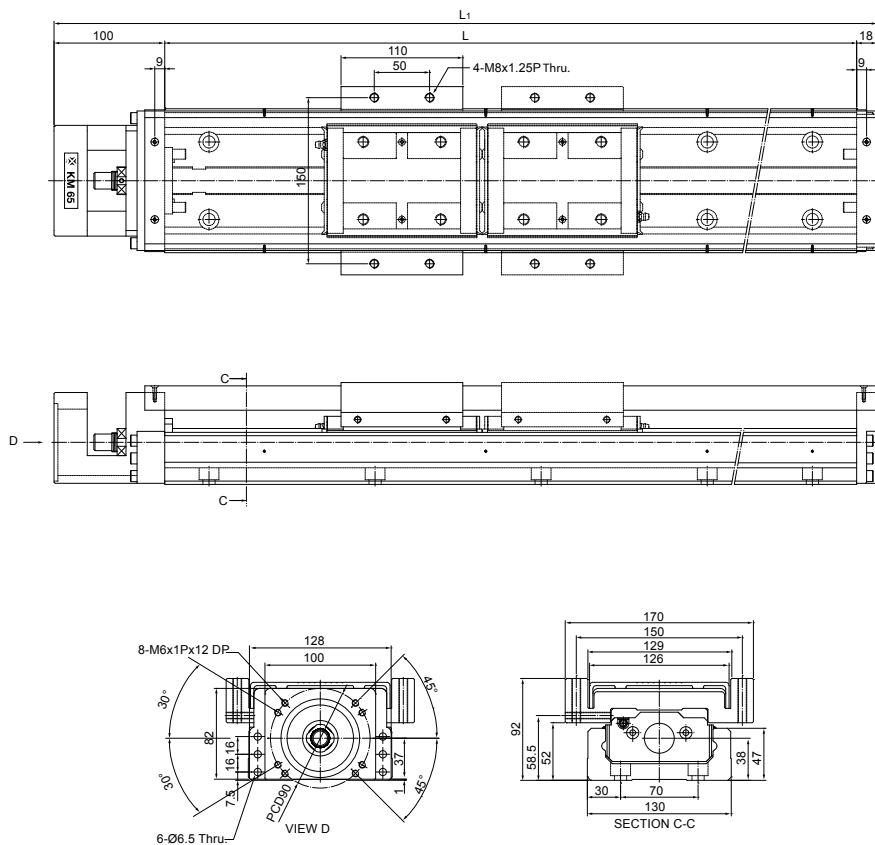

Unit : mm

Rail Length L	Overall Length L <sub>1</sub>	Max. Stroke		Weight (kg)	
		A Type	B Type	A Type	B Type
980	1098	800	655	31.60	34.60
1180	1298	1000	855	37.00	40.00
1380	1498	1200	1055	42.40	45.40
1680	1798	1500	1355	50.50	53.50

Note\*: The max. stroke of B type is base on two carriage-nuts used in closed contact with each other.

# Appendix

## PMI Ballscrew Request Form







Date :

Company :		Address :	
Tel :			
Fax :		Country :	
Machine Type :		Delivery Point :	
Application :		Desired Delivery Date :	Quantity :
1	<b>Required Specifications</b>		
	A. Thread Direction : <input type="checkbox"/> L <input type="checkbox"/> R    Number Of Thread (1~4) :		
	B. Screw Nominal O.D. :	Lead :	Effective Turns :
	C. Thread Length :    Overall Length :    Accuracy Grade :		
	D. Nut Type : <input type="checkbox"/> Miniature Series <input type="checkbox"/> End Deflector Series <input type="checkbox"/> External Ball Circulation Series <input type="checkbox"/> Internal Ball Circulation Series <input type="checkbox"/> High Lead Series <input type="checkbox"/> Heavy Load Series <input type="checkbox"/> End Cap Series		
2	<b>Load Condition</b>		
	A. Stroke :	mm   Max. Rotation Speed :	r.p.m   Motor Specifications :    kw
	B. Mounting Method : <input type="checkbox"/> Vertical <input type="checkbox"/> Horizontal <input type="checkbox"/> Oblique   Declining Angle :    Mounting Span :    mm		
	C. Acceleration Time :    S   Acceleration Speed :    m/s <sup>2</sup>   Rapid Feed Speed :    m/min		
	D. Life :    ×10 <sup>6</sup> revs      km      hr		
	E. Working Axial Load :		
	Rapid Feed :	kgf   Feed Speed :	mm/min   Time :    Ratio(%)
	Light Cutting :	kgf   Feed Speed :	mm/min   Time :    Ratio(%)
	Heavy Cutting :	kgf   Feed Speed :	mm/min   Time :    Ratio(%)
	F. Max. Axial Static Load :    kgf		
G. Table Weight :    kg   Work Piece Weight :    kg			
H. Linear Guide Way : <input type="checkbox"/> Ball Type <input type="checkbox"/> Roller Type   <input type="checkbox"/> Box Way			
I. Mount Method : <input type="checkbox"/> Fixed-Fixed <input type="checkbox"/> Fixed-Supported <input type="checkbox"/> Fixed-Free <input type="checkbox"/> Supported-Supported			
3	<b>Lead Accuracy, Axial Clearance, Preload and Stiffness</b>		
	A. Specified Travel (T) :    mm		
	B. Positioning Accuracy :    mm(No Load)   Repeatability Accuracy :    mm(No Load)		
	C. Preload :    kgf (Preload Torque :    kgf/cm)		
	D. Axial play :    mm (No Load)		
E. Nut Stiffness :    kgf/μm			
4	<b>Other Conditions</b>		
	A. Lubrication Oil :    Grease :    Other :		
	B. Ambient Temperature : <input type="checkbox"/> °C <input type="checkbox"/> °F		
C. Special Conditions :			

P.S. The specifications in this catalogue are subject to change without notification, For other special requirements, please contact us.

# PMI Linear Guideway Request Form

Date :

Customer Name :		Address :					
Tel :							
Fax :		Machine Type :					
Contact Person :		Drawing No. :					
Installation Direction							Others
	<input type="checkbox"/> H type	<input type="checkbox"/> R type	<input type="checkbox"/> V type	<input type="checkbox"/> K type	<input type="checkbox"/> T type	<input type="checkbox"/> RV type	
Carriage Type							
Size							
No. of Carriages	<input type="checkbox"/> 1 <input type="checkbox"/> 2 <input type="checkbox"/> 3 <input type="checkbox"/> 4 <input type="checkbox"/> Others:						
Dust Protection	<input type="checkbox"/> No symbol <input type="checkbox"/> UU <input type="checkbox"/> SS <input type="checkbox"/> ZZ <input type="checkbox"/> DD <input type="checkbox"/> KK <input type="checkbox"/> LL <input type="checkbox"/> RR						
Rail Protection	<input type="checkbox"/> No symbol <input type="checkbox"/> CC <input type="checkbox"/> MC <input type="checkbox"/> MD						
Preload Grade	<input type="checkbox"/> FZ <input type="checkbox"/> FC <input type="checkbox"/> F0 <input type="checkbox"/> F1 <input type="checkbox"/> F2						
Rail Type	<input type="checkbox"/> Counter-bore (R type) <input type="checkbox"/> Counter-bore (U type) <input type="checkbox"/> Tapped hole (T type)						
Rail Length & Pitch	Length: E1: E2: E3: E4:						
Accuracy Grade	<input type="checkbox"/> N <input type="checkbox"/> H <input type="checkbox"/> P <input type="checkbox"/> SP <input type="checkbox"/> UP						
Rail per Axis	<input type="checkbox"/> 1 <input type="checkbox"/> 2 <input type="checkbox"/> 3 <input type="checkbox"/> Others:						
Lubrication Type	<input type="checkbox"/> Grease <input type="checkbox"/> Oil						
Lubrication Fitting	<input type="checkbox"/> Grease nipple ( Code: ) <input type="checkbox"/> Oil piping joint ( Code: )						
Full Code of Specification							
Required Quantity							

## Reference surface & Lubrication Location

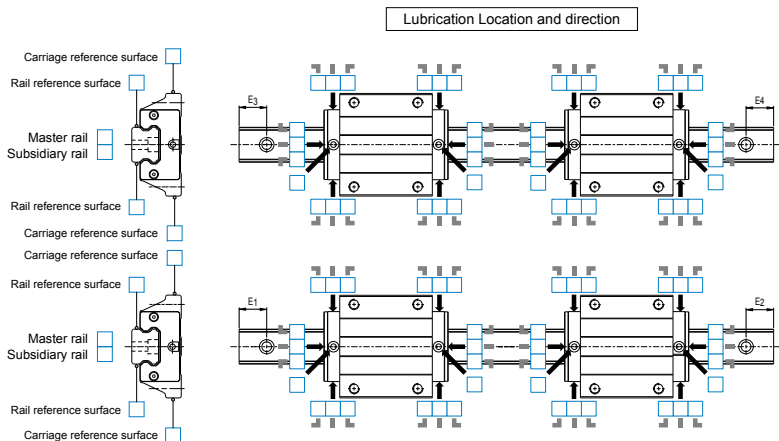

Nonspecified cases followed by **PMI** standards. For other special requirements, please contact us.

The specifications in this catalogue are subject to change without notification.

# Service Life Calculation of *PMI* Linear Guideway

Date :

Company :	Address :
Tel :	
Fax :	Machine Type :
Contact Person :	Others :

working condition

Velocity:

V=  m/sec

Acceleration time:

T1=  sec

T2=  sec

T3=  sec

Stroke length:

Ls=  mm

Number of reciprocations per minute:

N=  min<sup>-1</sup>

Thrust point:

A1=  mm

A2=  mm

Carriage span:

L1=  mm

Rail span:

L2=  mm

Mass:

m=  kg

Gravity point:

B1=  mm B3=  mm

B2=  mm

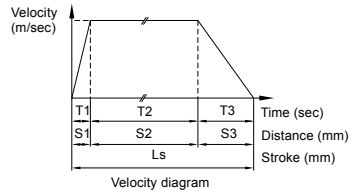

## Horizontal application

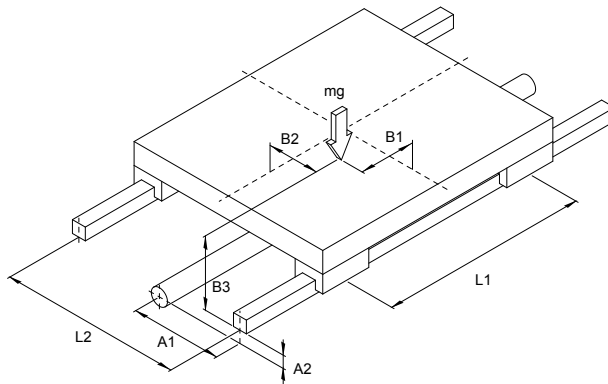

# Service Life Calculation of *PMI* Linear Guideway

Date :

Company :	Address :
Tel :	
Fax :	Machine Type :
Contact Person :	Others :

working condition

Velocity:

V=  m/sec

Acceleration time:

T1=  sec

T2=  sec

T3=  sec

Stroke length:

Ls=  mm

Number of reciprocations per minute:

N=  min<sup>-1</sup>

Thrust point:

A1=  mm

A2=  mm

Carriage span:

L1=  mm

Rail span:

L2=  mm

Mass:

m=  kg

Gravity point:

B1=  mm B3=  mm

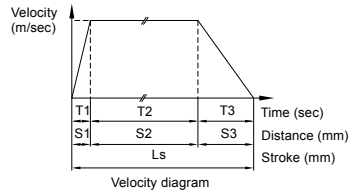

## Wall installation application

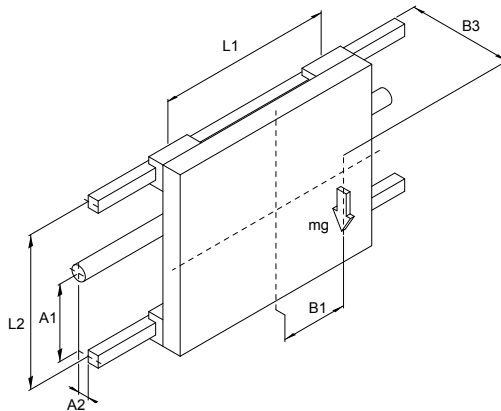

# Service Life Calculation of *PMI* Linear Guideway

Date :

Company :	Address :
Tel :	
Fax :	Machine Type :
Contact Person :	Others :

working condition

Velocity:

V=  m/sec

Acceleration time:

T1=  sec

T2=  sec

T3=  sec

Stroke length:

Ls=  mm

Number of reciprocations per minute:

N=  min<sup>-1</sup>

Thrust point:

A1=  mm

A2=  mm

Carriage span:

L1=  mm

Rail span:

L2=  mm

Mass:

m=  kg

Gravity point:

B1=  mm B3=  mm

B2=  mm  $\theta$ =  Degree

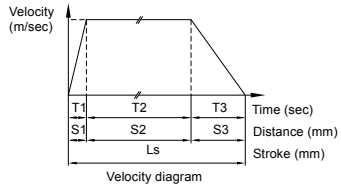

## Longitudinally tilted application

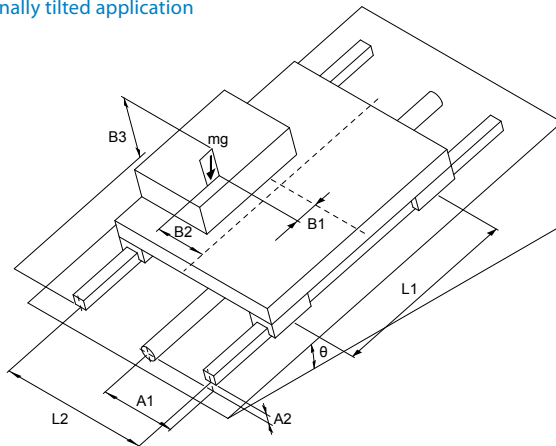



# Service Life Calculation of *PMI* Linear Guideway

Date :

Company :	Address :
Tel :	
Fax :	Machine Type :
Contact Person :	Others :

working condition

Velocity:

V=  m/sec

Acceleration time:

T1=  sec

T2=  sec

T3=  sec

Stroke length:

Ls=  mm

Number of reciprocations per minute:

N=  min<sup>-1</sup>

Thrust point:

A1=  mm

A2=  mm

Carriage span:

L1=  mm

Rail span:

L2=  mm

Mass:

m=  kg

Gravity point:

B1=  mm B3=  mm

B2=  mm  $\theta$ =  Degree

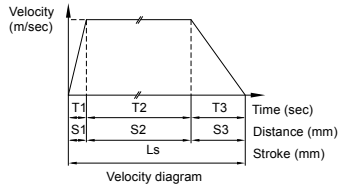

## Laterally tilted application

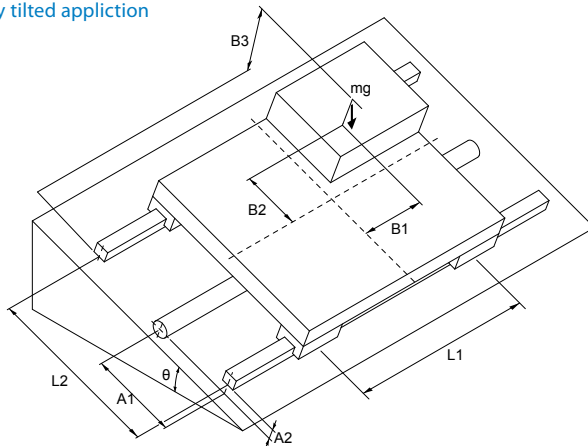

# Service Life Calculation of *PMI* Linear Guideway

Date :

Company :	Address :
Tel :	
Fax :	Machine Type :
Contact Person :	Others :

working condition

Velocity:

V=  m/sec

Acceleration time:

T1=  sec

T2=  sec

T3=  sec

Stroke length:

Ls=  mm

Number of reciprocations per minute:

N=  min<sup>-1</sup>

Thrust point:

A1=  mm

A2=  mm

Carriage span:

L1=  mm

Rail span:

L2=  mm

Mass:

m=  kg

Gravity point:

B1=  mm B3=  mm

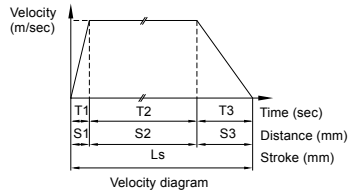

## Vertical application

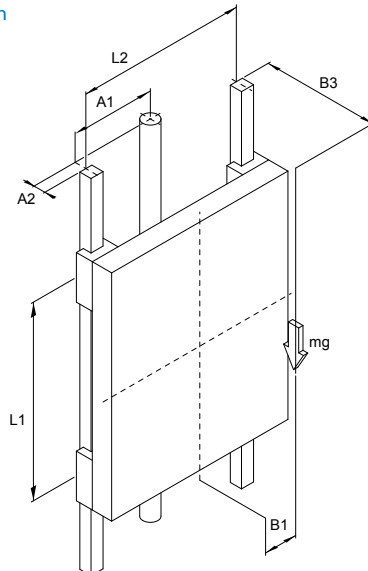





---

---

---

---

---

---

---

---

---

---

---

---

---

---

---

---

---

---

---

---

---

---

---

---

---

---

---

---

---

---

