

# SMITH BEARING®

*Product Catalog*

Cam Followers, Needle Bearings, Bushings and Special Assemblies for Aerospace & Industrial Applications



SMITH BEARING® is a registered trademark of **A=B=C** accurate bushing co.

*Accuracy is Our Best Policy*

**SMITH BEARING®** is a registered trademark of **ABC** accurate bushing co.

**CORPORATE HEADQUARTERS**

443 North Avenue  
Garwood • NJ • 07027 • USA  
tel: **908.789.1121**  
fax: **908.789.9429**  
**800.932.0076**

Smith Bearing® is a registered trademark of Accurate Bushing Company. With over 50 years experience in designing and manufacturing precision needle roller bearings, we can handle your requirements for standard aerospace and industrial bearings, as well as custom manufactured special bearings, assemblies, and bushings.



In this catalog you will find our complete range of precision bearings including:

Cam Follower Needle Roller Bearings in Inch & Metric sizes, Stainless Steel Cam Followers for special corrosive applications, Cam Followers with self-lubricating engineered plastic bushings, **Smith-Trax®** with tapered roller bearings and deep-groove ball bearings for high-thrust load applications, Aerospace and Military approved Needle Roller Bearings for engine and airframe applications, Spherical Plain Bearings, Drill Jig Bushings and Specialty Aerospace products and assemblies.

As well as our existing product line, we are ready to assist you with the manufacture of custom made products, precision machine components and assemblies. **ISO 9001 and AS 9100 registered.**

**Smith Bearing®** serves the global market place with a network of Industrial and Aerospace distributors, manufacturing plants and sales offices throughout the world. The structure of our operation affords us the ability to give highly personalized attention to every customer. Most importantly, this structure gives us the ability to respond immediately to our customers request as well as providing highly cost-effective products.

Email: [sales@smithbearing.com](mailto:sales@smithbearing.com) Phone: **800.932.0076**

## Standard & Custom Bearings and Special Assemblies for Aerospace & Industrial Applications

*All products in this catalog subject to Accurate Bushing Company terms and conditions, a copy of which is available in the back of this catalog or may be requested from the customer service department.*

SMITH Bearing, SMITH-TRAX, & SMITH-ALIGN are registered trademarks of Accurate Bushing Company.  
Copyright © 2004 Accurate Bushing Company. All rights reserved.

**SMITH BEARING®** is a registered trademark of **A=C** accurate bushing co.

## Standard & Custom Bearings and Special Assemblies for Aerospace & Industrial Applications



### **CORPORATE HEADQUARTERS**

443 North Avenue  
Garwood • NJ • 07027 • USA

tel: **908.789.1121**

fax: **908.789.9429**

**800.932.0076**

[www.smithbearing.com](http://www.smithbearing.com)

[www.accuratebushing.com](http://www.accuratebushing.com)

*All products in this catalog subject to Accurate Bushing Company terms and conditions, a copy of which is available in the back of this catalog or may be requested from the customer service department.*

SMITH Bearing, SMITH-TRAX, & SMITH-ALIGN are registered trademarks of Accurate Bushing Company.  
Copyright © 2004 Accurate Bushing Company. All rights reserved.

# Needle Bearings, Bushings and Special Assemblies for Aerospace & Industrial Applications



## SMITH BEARING®

is a registered trademark of ABC • Accurate Bushing Company

### CAM FOLLOWERS: (Needle Rollers) Yoke Type & Stud Type

We offer a complete line of stud type and yoke type cam followers for industrial applications. These bearings are available in steel, stainless steel, and with engineered plastic internal bushings. We specialize in engineered cam followers to fit specific applications.

- Inch Sizes
- Metric Sizes
- Stainless Steel
- Bearings with Non-Metallic Bushings



### SMITH-TRAX® Bearings

The SMITH-TRAX® special duty track roller bearings are machined from high-alloy steel and are case-hardened for maximum longevity. These bearings are fitted with deep-groove ball bearings or tapered roller bearings to handle both high radial and thrust load applications.

- Inch Sizes
- Metric Sizes
- Stainless Steel



### AEROSPACE BEARINGS

We are approved to manufacture bearings to military and aerospace specifications. The bearings we produce meet the standards of AS-3990. Our engine bearings are currently used in thrust reversers, after burners and divergent nozzles. Our airframe bearings are used in flap-tracks, canopies and landing gear.

- MS21438
- MS21439
- MS24465
- MS24466
- MS24461
- MS21432
- MS21447



### CUSTOM ENGINEERED PRODUCTS & ANCILLARY BEARINGS

We will manufacture custom design bearings in small and large quantities to meet your specifications. Please contact our engineering department with your requirements.

- Inner Ring Races
- Chain Rollers
- Spherical Plain Bearings

### DRILL JIG BUSHINGS

ABC Drill Jig Bushings are manufactured to ANSI standard tolerances and produced from select steels known for their long wear and stability. Special bushings are available.





















## CAPABILITIES & ENGINEERING



1-10

### SECTION 1: CAM FOLLOWERS













### (Needle Rollers) Yoke Type & Stud Type

Inch Sizes			11
	<b>CR</b>	Inch • Stud Type • Screwdriver • Unsealed	12
	<b>CR-X</b>	Inch • Stud Type • Screwdriver • Sealed	12
	<b>CR-B</b>	Inch • Stud Type • Hex-Drive • Unsealed	13
	<b>CR-XB</b>	Inch • Stud Type • Hex-Drive • Sealed	13
	<b>CR-XBE</b>	<b>Eccentric</b> Crowned & Uncrowned	14-15
	<b>HR</b>	Inch • Heavy Stud • Screwdriver • Unsealed	16
	<b>HR-X</b>	Inch • Heavy Stud • Screwdriver • Sealed	16
	<b>HR-B</b>	Inch • Heavy Stud • Hex -Drive • Unsealed	17
	<b>HR-XB</b>	Inch • Heavy Stud • Hex -Drive • Sealed	17
	<b>YR</b>	Inch • Yoke Type • Unsealed	18
	<b>YR-X</b>	Inch • Yoke Type • Sealed	18
Inch Sizes		Crowned	19
	<b>CR-C</b>	Inch • Stud Type • Screwdriver • Unsealed • Crowned	20
	<b>CR-XC</b>	Inch • Stud Type • Screwdriver • Sealed • Crowned	20
	<b>CR-BC</b>	Inch • Stud Type • Hex-Drive • Unsealed • Crowned	21
	<b>CR-XBC</b>	Inch • Stud Type • Hex-Drive • Sealed • Crowned	21
	<b>HR-C</b>	Inch • Heavy Stud • Screwdriver • Unsealed • Crowned	22
	<b>HR-XC</b>	Inch • Heavy Stud • Screwdriver • Sealed • Crowned	22
	<b>HR-BC</b>	Inch • Heavy Stud • Hex-Drive • Unsealed • Crowned	23
	<b>HR-XBC</b>	Inch • Heavy Stud • Hex-Drive • Sealed • Crowned	23
	<b>YR-C</b>	Inch Size • Yoke Type • Unsealed • Crowned	24
	<b>YR-XC</b>	Inch Size • Yoke Type • Sealed • Crowned	24
	<b>DCR</b>	<b>Double Row • Heavy Roller • Stud Type • Interchange</b>	26
	<b>DYR</b>	<b>Double Row • Heavy Roller • Yoke Type • Interchange</b>	27
<b>Interchange Tables:</b> Cam Followers - <b>INCH</b> Sizes - Yoke Type & Stud Type • <b>Unsealed</b>			28
Cam Followers - <b>INCH</b> Sizes - Yoke Type & Stud Type • <b>Sealed</b>			29
Inch Sizes		Stainless Steel	
	<b>CR-SS</b>	Inch • Stud Type • Screwdriver • Unsealed	30
	<b>CR-X-SS</b>	Inch • Stud Type • Screwdriver • Sealed	
	<b>CR-B-SS</b>	Inch • Stud Type • Hex Drive • Unsealed	31
	<b>CR-XB-SS</b>	Inch • Stud Type • Hex Drive • Sealed	
	<b>YR-SS</b>	Inch • Yoke Type • Unsealed	32
	<b>YR-X-SS</b>	Inch • Yoke Type • Sealed	
<b>Interchange Tables:</b> Cam Followers - <b>Stainless Steel</b>			33



Inch Sizes	With Non-Metallic Bushing	
 <b>BCR</b> <b>BCR-X</b>	Inch • Stud Type • Screwdriver • Unsealed Inch • Stud Type • Screwdriver • Sealed	<b>34</b>
 <b>BCR-B</b> <b>BCR-XB</b>	Inch • Stud Type • Hex Drive • Unsealed Inch • Stud Type • Hex Drive • Sealed	<b>35</b>
 <b>BYR</b> <b>BYR-X</b>	Inch Size • Yoke Type • Unsealed Inch Size • Yoke Type • Sealed	<b>36</b>
<b>Interchange Tables: Cam Followers - Non-Metallic Bushing</b>		<b>37</b>

Metric		
 <b>MCR</b> <b>MCR-S</b> <b>MCRV</b> <b>MCRV-S</b>	Metric • Stud Type • Unsealed • Caged Metric • Stud Type • Sealed • Caged Metric • Stud Type • Unsealed • Full Complement Metric • Stud Type • Sealed • Full Complement	<b>38-39</b>
 <b>MYR</b> <b>MYR-S</b> <b>MYRV</b> <b>MYRV-S</b>	Metric • Yoke Type • Unsealed • Caged Metric • Yoke Type • Sealed • Caged Metric • Yoke Type • Unsealed • Full Complement Metric • Yoke Type • Sealed • Full Complement	<b>40</b>
 <b>NUKR</b> <b>MUTD</b>	Metric Yoke • Double Row • Heavy Roller • Full Complement • <b>Interchange</b> Metric Stud • Double Row • Heavy Roller • Full Complement • <b>Interchange</b>	<b>41</b> <b>42</b>
<b>Interchange Tables: Cam Followers - METRIC Sizes - Yoke Type &amp; Stud Type</b>		<b>43</b>

## SECTION 2: SMITH-TRAX® Bearings

Inch Sizes	SMITH-TRAX® Bearings	
 <b>PCR</b>	Inch • Plain Stud Type	<b>46</b>
 <b>FCR</b>	Inch • Flange Type	<b>47</b>
 <b>VCR</b>	Inch • V-Grooved Stud Type	<b>48</b>
 <b>UCR</b>	Inch • U-Grooved Stud Type	<b>49</b>
 <b>PYR</b>	Inch • Plain Yoke Type	<b>50</b>
 <b>FYR</b>	Inch • Flange Yoke Type	<b>51</b>
 <b>VYR</b>	Inch • V-Grooved Yoke Type	<b>52</b>
Metric	SMITH-TRAX® Bearings	
 <b>MPCR</b>	Metric • Plain Stud Type	<b>54</b>
 <b>MFCR</b>	Metric • Flange Type	<b>55</b>
 <b>MVCR</b>	Metric • V-Grooved Stud Type	<b>56</b>
 <b>MPYR</b>	Metric • Plain Yoke Type	<b>57</b>
 <b>MFYR</b>	Metric • Flange Yoke Type	<b>58</b>
 <b>MVYR</b>	Metric • V-Grooved Yoke Type	<b>59</b>
<b>Interchange Tables: Inch &amp; Metric Smith®-Trax</b>		<b>60-61</b>









**SECTION 3: ANCILLARY BEARINGS**

	<b>IRR</b>	Inner Ring Races • <b>Interchange</b>	<b>62</b>
	<b>YR</b>	Chain Rollers	<b>64</b>
	<b>GEZ</b>	Spherical Plain Bearings	<b>65</b>

**SECTION 4: AEROSPACE BEARINGS**

**General Information**



**66-67**

	<b>MS21438/YAF</b>	Airframe Needle Bearings • Track Rollers - Single Row	<b>68</b>
	<b>MS21439/YAT</b>	Airframe Needle Bearings • Track Rollers - Double Row	<b>68</b>
	<b>MS24465/YAD</b>	Airframe Needle Bearings • Track Rollers - Single Row	<b>69</b>
	<b>MS24466/YAS</b>	Airframe Needle Bearings • Track Rollers - Double Row	<b>69</b>
	<b>MS24461/YAG</b>	Airframe Needle Bearings - Single Row	<b>70-71</b>
	<b>MS21432/HRS</b>	Airframe Needle Bearings • Integral Stud	<b>72</b>
	<b>MS21447/CHRS</b>	Airframe Needle Bearings • Integral Stud - Crowned	<b>73</b>
<b>Interchange Tables: Aerospace Bearings</b>			<b>74-75</b>
	<b>SEB/SEBF Series</b>	Spherical Slotted Entry Bearings	<b>76-77</b>
	<b>F Series</b>	Spherical <b>Smith-Align®</b> Bearings	<b>78</b>

**SECTION 5: DRILL JIG BUSHINGS**

**General Information**

**81**

	<b>Fractional Chart</b>		<b>80</b>
	<b>Type "P"</b>	Headless Press-Fit	<b>82-83</b>
	<b>Type "H"</b>	Head Press-Fit	<b>84-85</b>
	<b>Type "F"</b>	Fixed Renewable	<b>86-87</b>
	<b>Type "SF"</b>	Slip-Fixed Renewable	<b>88-89</b>
	<b>Type "L"</b>	Headless Liner	<b>90</b>
	<b>Type "HL"</b>	Head Liner	<b>91</b>
	<b>Miscellaneous Hardware</b>		<b>92</b>

**SECTION 7: INTERCHANGE TABLES**

**93-103**

<b>Cam Followers (Needle Rollers) Yoke &amp; Stud Type • Inch &amp; Metric</b>	<b>94-99</b>
<b>Smith-Trax®</b>	<b>100-101</b>
<b>Aerospace</b>	<b>102-103</b>

<b>Blank Note Pages</b>	<b>104-107</b>
-------------------------	----------------

<b>Terms &amp; Conditions</b>	<b>108</b>
-------------------------------	------------

### MACHINERY & TESTING FACILITIES

**Smith Bearing®** has a fully-integrated manufacturing facility capable of producing high-precision needle roller bearings for both the Aerospace and Industrial market. Our computerized (CNC) grinding and precision machining centers, considered to be the most advanced in the industry are capable of manufacturing a wide range of products to exacting tolerances in order to meet the needs of our customers. Our advanced metallurgical department routinely verifies and tests all raw materials, plating and heat-treating processes used in the manufacturing of our products. This careful analysis and scrutiny in each phase of our procedure assures proper conformance to all Aerospace requirements and guarantees that only materials meeting our rigid standards are used in **Smith Bearing®** products.

### ENGINEERING

Extensive experience in our engineering department allows **Smith Bearing®** to work closely with end-users and OEMs (original equipment manufactures) in order to offer the best solution for their bearing requirements. **Smith Bearing®** engineers have extensive knowledge of available metallurgies so that they may offer customers their experience to determine the best suitable material for a special design and application. Smith manufactures bearings in a wide range of materials including high-carbon alloy steels, stainless steels, tool steels, and other exotic alloys.

### CUSTOM ASSEMBLIES

**Smith Bearing®** has the ability to manufacture a variety of custom bearing assemblies. Typically this entails the precision machining of a bearing housing and the assembly of needle or ball bearings into the housing. By controlling the entire design and manufacturing process of a custom order, Smith Bearing® guarantees the quality, performance, and delivery of an assembly. Smith Bearing® performs all aspects of such projects from design to finish including the machining process, applications of special coatings and plating, assembling and testing of the final product.

### QUALITY & DEPENDABILITY

**Smith Bearing®** has received both **ISO 9001** and **AS 9100** quality registrations in recognition of our continued commitment to world-class quality control systems. Our quality system is recognized by General Electric, Lockheed, Boeing Aircraft Corporation, British Aerospace, as well as many other military and aerospace companies. Our Military bearings meet the requirements of **Mil-B-3990 (SAE AS 39901)**. This level of quality certifications and approvals assures our customers unequalled dependability of our products.





## Cam Followers – Stud & Yoke Type

**SMITH Cam Followers** are anti-friction needle roller bearings developed for use in cam or track roller applications. They were specifically designed and built to handle intermittent shock and heavy loads. Full compliment (non-caged) needle bearings maximize the radial load carrying capability while the soft inner core of the stud gives these cam followers the ability to absorb extreme shock loads without fracturing.

In addition to standard models, special bearings are manufactured to customer specification for unique applications. It is often found that the use of special bearings reduces machine costs and improves performance. We have the ability to economically manufacture custom bearings in small or large volumes. Please call us to discuss your special applications.

### Material Selection

The common material selection for needle roller bearings are high-strength bearing steel (SAE 52100) or carburized low-carbon alloy steels. These materials give us an excellent combination of strength and economy and are more than sufficient for the majority of industrial applications.

### High-Temperature & Corrosive Applications:

In extreme applications where bearings are being subjected to high-temperature or corrosive environments, alternative materials or special platings must be considered.

**Smith Bearing®** manufactures needle roller bearings in a wide variety of high-temperature and corrosive resistant exotic alloys including **440-C stainless steel** and **M-50, M-2, M-10 tool steels**.

Corrosion resistant plating is effective when using bearings in corrosive environments. Non-bearing surfaces such as inner races and end washers are cadmium plated to resist corrosion. The outer races of the bearings are typically hard-chrome plated to resist wear as well as corrosion.

### Construction of Standard Needle Rollers

Cam Follower materials and finishes are selected to provide a minimum of friction and to assure dependable performance for the required service life.

**OUTER RACE** High-carbon chrome bearing steel (SAE 52100), hardened and ground.

**INNER RACES** are manufactured from low-carbon alloy steel, carburized, and case hardened on the raceway area. This gives the inner race two very key characteristics. **1):** Tremendous strength and forgiveness when subject to tensile, shear, and other bending stresses and **2):** extreme hardness on the wear area for long bearing life. The studs are metallurgically designed not to fracture or fail when subject to intermittent shock and heavy loads found in cam follower applications.

**NEEDLE ROLLERS** are made from high-carbon chrome bearing steel. They are through-hardened, ground and lapped for ultimate life and performance.

**RETAINING WASHERS** are made from low-carbon alloy steel, and case-hardened. This gives both a hardened and smooth internal surface that is desirable for proper cam follower performance. The soft core of the end washer resists fracture during use.

### Various Needle Rollers - Stud & Yoke Type



#### REGULAR STUD TYPE CR Series

are recommended where loads and shock are moderate. Bearing capacity on the CR Series is limited by their moderately sized stud. See capacity ratings.



#### HEAVY STUD TYPE HR Series

are recommended for applications with high-loads and/or heavy shock and where deflection should be held to a minimum. Rollers and outer races are identical to the standard CR Series.

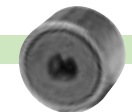

#### YOKE TYPE YR Series

have similar internal construction to the stud type CR Series except the inner race is made for shaft or clevis mounting. Generally, heavier loads can be supported by the yoke mounting arrangement, since stud deflection is removed from consideration.



#### HEX-DRIVE SOCKET Add Suffix "B"

are favorable for most applications where the bearing is installed in a blind or threaded hole. The Hex-drive allows for more secure installation and easier removal of the cam follower.



#### SCREWDRIVER SLOT Standard

Screw-driver slot configuration is normally sufficient for most applications.

Cam Followers – Stud & Yoke Type



**ECCENTRIC CAM FOLLOWERS**

**Add Suffix "E"**

The eccentric sleeve allows for easy radial positioning for stud-type cam followers.

**Eccentric Sleeves Allow for Radial Location Adjustment of Cam Followers**

Cam Followers with a Press Fit **Eccentric Sleeve** provide correct alignment and adjustment without costly preparation of close tolerance mounting holes and members. They eliminate problems of clearances, preloading and wear compensation and assure load sharing in multiple cam follower applications. The hex-drive socket allows positive torque for locking and adjustment. A lock nut will normally provide adequate clamping to hold bearing and eccentric sleeve in their proper position. When permanent locking of eccentric sleeve is required, drill through the housing, eccentric sleeve, and bearing stud and secure with a dowel or set-screw.

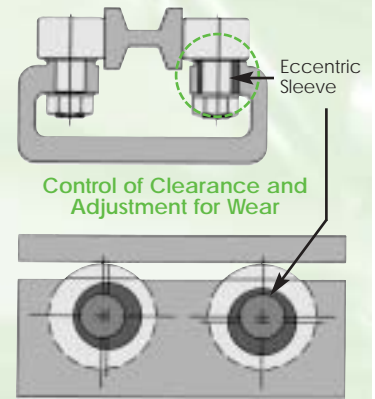

Control of Clearance and Adjustment for Wear

In-line Adjustment Allows Greater Location Tolerance for Mounting Holes



**CROWNED CAM FOLLOWERS**

**Add Suffix "C"**

Crowned outer races are recommended when the track is not exactly aligned and square with the cam follower. Crowned outer races reduce undesirable thrust loads on the rollers when track-bearing misalignment happens to occur. This increases life and reliability of the bearing.

Available in stud type and yoke type cam followers.

**Crowned Outer Races Reduce Edge Loading when Bearing/Track are Misaligned**

Unwanted edge loading of needle bearings causes skewing and end thrusting of the needles which contribute to premature bearing failure. In situations where it is impractical or too costly to provide for perfect alignment, crowned bearing O.D.'s provide compensation for misalignment between the cam follower and the surface of a slanted track or cam. The radius also eliminates skidding of the outer race when bearing is on contact with a flat, circular cam.

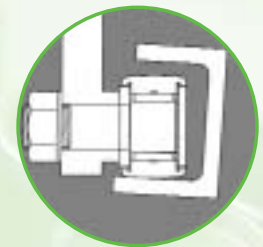

**SEALED CAM FOLLOWERS**

**Add Suffix "X"**

Seals provide an effective means of protection from outside contamination and ensure lubricant retention.

Available in stud type and yoke type cam followers.

**Seals Provide Protection Against Contamination & Loss of Lubricant**

Sealed cam followers are furnished with molded-acetyl full-contact seals contained within the outer race undercuts at both ends of the bearing. This is a low-friction material which keeps drag to a minimum yet is stable and unaffected by corrosive agents or lubricants. A small vent hole in the seals allows for purging during relubrication without causing seal displacement. The outer race on sealed cam followers is provided with a machined groove in the bore, which acts as a grease reservoir to extend time periods between relubrication. All sealed bearings are dimensionally interchangeable with the unsealed configuration of the same series.

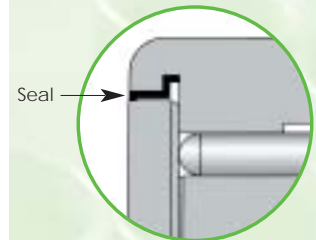

Typical Seal Configuration

Cam Followers – Stud & Yoke Type

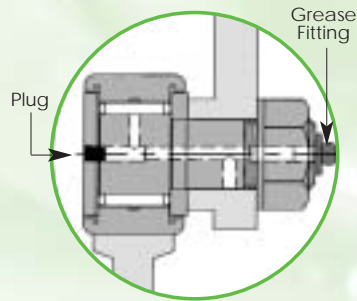

Fig. 1 Lubrication Through Thread-End

Fig. 1 shows the re-lubrication path through the threaded-end of the stud (white area). The head-end is properly closed off using one of the two the plugs provided with each cam follower. Due to diameter constraints of the stud, smaller cam followers cannot be re-lubricated through the threaded-end.

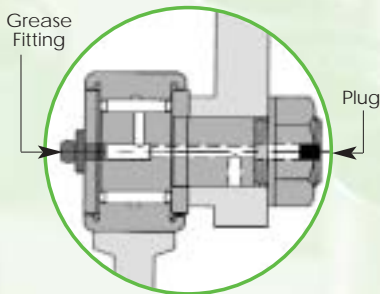

Fig. 2 Lubrication Through Head-End

Fig. 2 shows the re-lubrication path through the head-end of the stud (white area). The threaded-end is properly closed off using one of the two the plugs provided with each cam follower.

Note: Smaller cam followers with hex-drive socket can only be re-lubricated through threaded-end. See dimensional charts.

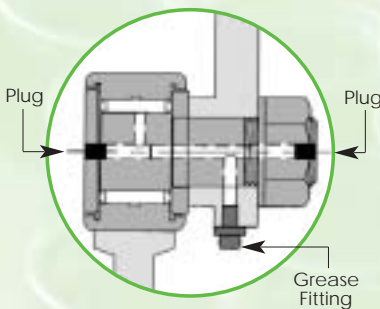

Fig. 3 Lubrication Through Center-Hole

Fig. 3 shows the re-lubrication path through the cross-drilled hole in the stud of the cam follower (white area). A lubrication grease fitting must be installed in the housing of the equipment. In this case, the threaded-end and head-end are properly closed off using both of the plugs provided with each cam follower.

Lubrication

Cam Followers and Cam Yoke Rollers are packed at the factory with a petroleum-base, lithium grease with extreme pressure and corrosive resistant additives. This lubricant is suitable for most bearing applications within a temperature range of -30 °F to 250 °F. Re-lubrication in service can be accomplished with any non-soap based roller bearing grease or oil. Special greases or oils can be specified if required.

Frequency of lubrication will depend upon the speed of bearing rotation, contaminants present in the application and the type of lubricant used. In continuously rotating applications, constant oil lubrication or frequent grease lubrication may be necessary.

**Stud-Type Cam Followers** can be re-lubricated in three areas: through either end of the stud (head-end or threaded-end) or through the cross-drilled hole in the stud. The four smallest size cam followers (CR-1/2, CR-9/16, CR-5/8, CR-11/16) can be re-lubricated through the head-end only due to the diameter constraints of the stud. The axial lubrication hole in the stud is linked to a radial hole in the raceway of the bearing allowing the lubricant to reach the needles. The ends of the stud are counter-bored and precision-reamed to accept a drive-type lubrication grease fitting (not furnished). Two precision-machined plugs are supplied with each cam follower and should be pressed into the unused re-lubrication holes in the end of the studs. The housing that the cam follower is mounted into serves to block the cross-drilled re-lubrication hole in the stud when the re-lubrication hole is not being used. (See Fig 1 & 2).

**Yoke Rollers** can be re-lubricated through the oil holes that are drilled in the inner race of the bearing. The mounting pin that supports the bearing must be drilled so that lubrication hole lines up with the oil hole in the bearing.

For grease relubrication of the Cam Follower **CR** Series and **HR** Series, the following drive type fittings are suggested:

Cam Follower Size	Lubrication Fitting
CR-1/2 to CR-11/16 HR-1/2 to HR-5/8	1/8" Alemite Fitting #3019
CR-3/4 to CR-23/4 HR-3/4 to HR-23/4	3/16" Alemite Fitting #1728-B, #1633, #1645-B, #3005, #3006, #3009, #3012-BB
CR-3 to CR-4 HR-3 to HR-4	1/4" Alemite Fitting #1743 or #1743-B
CR-5 to CR-6	1/4" N.P.T. fitting

## Cam Followers – Stud &amp; Yoke Type

**Mounting Stud-Type Cam Followers**

Proper cam follower mounting requires a close precision fit between the stud and housing bore. We recommend using bore sizes provided in the dimensional tables. An arbor press is the preferred means of stud installation with pressure applied to the central area of the stud, not to the outer flange edges.

In positioning the cam follower, the end washer should be firmly supported by the shoulder of the machine member, which must be square with the centerline of the stud. The shoulder should be at least as large as the minimum boss diameter given in the dimensional tables as denoted by the "E" dimension (**Fig. 4**). It is also important that the alignment be maintained between the bearing axis and the cam or track surface to prevent edge loading of the bearing outer race. The dimensional tables list the recommended torque to be applied to the nut. Excessive torque, in particular with small sizes, may damage the internal elements. Torque value for lubricated threads should be reduced by half the value given in the dimensional tables.

**Mounting Yoke-Type Cam Followers**

The mounting of yoke rollers should provide for endwise clamping to prevent axial movement and displacement of the end washer. The end washer should be firmly supported by a flat housing shoulder, which must be square with the centerline of the bearing. The shoulder should be at least as large as the minimum clamping diameter shown in the dimensional tables as denoted by the "E" dimension (**Fig. 5**) to provide adequate washer support.

The recommended shaft diameters listed in the dimensional tables provide for either a slip or press fit. In applications with extreme loads, the stud should be heat-treated and press-fit into the bearing bore. With moderate loads, a hardened stud should be used but a slip-fit is sufficient. In lightly loaded applications, a slip-fit may be used with a non-hardened stud.

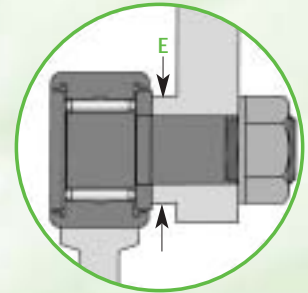

**Fig. 4** Mounting of a Stud Type Cam Follower

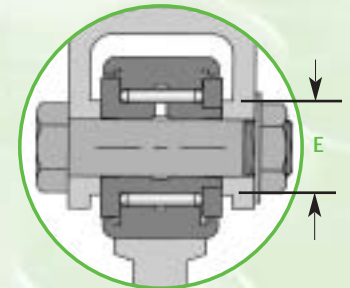

**Fig. 5** Mounting of a Yoke Type Cam Follower

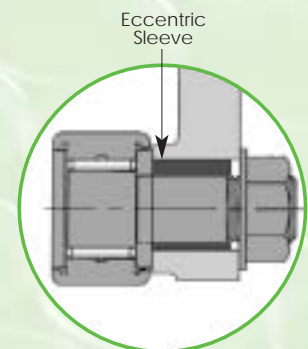

**Fig. 6** Mounting of a Stud Type Cam Follower with Eccentric Sleeve

## Bearing Life &amp; Load Calculations

**Bearing Life**

Properly selected bearings that have been suitably mounted and lubricated will operate for extended periods of time with minimal wear until the fatigue life of the rolling elements is reached. Fatigue life of a bearing is reached when "spalling" or flaking of the contact surfaces (rolling element and raceway) occur from repeated stresses. Once the fatigue life of the rolling element or raceway is reached, wear and ultimate failure of the bearing will occur very rapidly. The purpose is to select the proper type and size of bearing for the intended application in order to optimize performance and operating life.

The life of a bearing can be defined in terms of hours of operation or number of revolutions the bearing will endure before failure. We need to keep in mind that some variations between individual bearings that look identical do exist. The most common definition of bearing life as defined by the ABMA (American Bearing Manufacturer's Association) is referred to as the **L<sub>10</sub> life**. The "**L<sub>10</sub> life**" of a bearing is the number of hours that 90% of a group of seemingly identical bearings will operate prior to fatigue failure occurring. The **L<sub>10</sub> life** can also be expressed in the number of revolutions when the speed is known. When selecting a bearing the machine designer should select an appropriate **L<sub>10</sub> life** for the particular application.

Note: Larger bearings will have a longer expected life than smaller bearings under identical conditions. Heavier loads will decrease the expected life of a bearing. Therefore, to maximize operating life, the largest bearing possible should be used. See equations to right.

**Bearing Size and Selection**

Once the type of bearing for a specific application has been selected, the designer must then choose the size of bearing required for the application. The larger the bearing the larger the load it is capable of handling. The **Basic Dynamic Rating (BDR)**, or its equivalent is an indication of how much dynamic load a given bearing size can handle. This rating is a reference value only and is based on an **L<sub>10</sub> life** of 500 hours at a rotation speed of 33<sup>1/3</sup> RPM. In actual practice, the bearing should never be subjected to more than 50% of this value. The **Maximum Static Capacity** is the largest static load that can be applied to the bearing before the rolling elements become permanently deformed. For stud type cam followers, the maximum static capacity is the largest static load that can be applied before the stud will bend or deform.

The life expectancy (**L<sub>10</sub> life**) in hours of a bearing can be calculated by using the following formula:

$$L_{10} = \frac{16,666}{N} \left( \frac{BDR}{P} \right)^{10/3}$$

The **Basic Dynamic Rating (BDR)** required for a given application can be calculated by using following formula:

$$BDR = .054 \times P \times (L_{10} \times N)^{.3}$$

**L<sub>10</sub>** = Life of the bearing in hours of operation

**BDR** = Basic Dynamic Rating of the bearing

**P** = Radial Load (lbs)

**N** = Speed (RPM)

## Bearing Life & Load Calculations

### Example 1:

Determine the **L<sub>10</sub> life** of a **CR-7/8** cam follower operating at a speed of **500 RPM** under a load of **750 lbs**:

Find the **Basic Dynamic Rating (BDR)** in the specification page for the **CR-7/8** cam follower:

**BDR (Basic Dynamic Rating) = 2140 lbs**

From the given formula:

$$L_{10} = \frac{16,666}{N} \left( \frac{BDR}{P} \right)^{10/3}$$

$$L_{10} = \frac{16,666}{500} \left( \frac{2140}{750} \right)^{10/3}$$

$$L_{10} = 1098 \text{ hrs.}$$

**Note:** This shows the expected operating life for the **CR-7/8** under the above conditions is 1098 hours. If a longer life span is desired and room for installation permits, a larger bearing with a higher Basic Dynamic Rating (BDR) could be selected. For example: a **CR-1 1/4** cam follower with a BDR (Basic Dynamic Rating) of **4470 lbs** will operate for 12,794 hours in the identical application.

### Example 2:

Determine the required **Basic Dynamic Rating (BDR)** for a bearing that will be operating at **1000 RPM** with an applied load of **400 lbs**. The machine designer has determines that the application requires an **L<sub>10</sub> life** of **15,000 hrs**.

From the given formula:

$$BDR = .054 \times P \times (L_{10} \times N)^{.3}$$

$$BDR = .054 \times 400 \times (15,000 \times 1,000)^{.3}$$

$$BDR = 3071 \text{ lbs}$$

**Note:** A **CR-1 1/4** cam follower with a Basic Dynamic Rating (BDR) of **4470 lbs**. would be chosen for this application. If A **CR-1** cam follower with a Basic Dynamic Rating (BDR) of **3030 lbs** were used, the operating life would be reduced to **14,226 hrs**. See Example 1.

### Bearing Life Calculations using Speed Factor & Life Factor Charts

An alternative method for determining the **L<sub>10</sub> life** or the desired **Basic Dynamic Rating (BDR)** required for a particular application is by using the **SPEED Factor** and **LIFE Factor** charts. Use given formula below:

**BDR = Applied Load x (SF) Speed Factor x (LF) Life Factor**

### Example 3:

Determine the **Basic Dynamic Rating (BDR)** for a bearing that will be operating at **250 RPM** with an applied load of **2000 lbs**. The required **L<sub>10</sub> life** for the application is **600 hrs**.

From the given formula above and using Speed and Life Charts below:

**BDR = Applied Load x (SF) Speed Factor x (LF) Life Factor**

**BDR = 2000 x 1.83 x 1.064**

**BDR = 3895 lbs**

#### Speed Factors Chart

RPM	SF	RPM	SF
33 <sup>1</sup> / <sub>3</sub>	1.000	1200	2.940
40	1.056	1300	3.000
50	1.120	1400	3.070
60	1.193	1500	3.125
70	1.249	1600	3.200
80	1.300	1700	3.250
90	1.347	1800	3.310
100	1.390	1900	3.365
125	1.499	2000	3.420
150	1.570	2100	3.460
175	1.644	2200	3.520
200	1.712	2400	3.610
250	1.830	2600	3.700
300	1.935	2800	3.780
350	2.025	3000	3.860
400	2.105	3200	3.930
450	2.185	3400	4.010
500	2.250	3600	4.070
600	2.380	3800	4.150
700	2.490	4000	4.210
800	2.590	4200	4.270
900	2.690	4400	4.330
1000	2.780	4600	4.380
1100	2.850	4800	4.440

#### Life Factors Chart

L <sub>10</sub> Life (hrs)	LF	L <sub>10</sub> Life (hrs)	LF
500	1.000	16,000	2.83
600	1.064	18,000	2.93
700	1.102	20,000	3.03
800	1.151	25,000	3.24
900	1.193	30,000	3.42
1000	1.231	35,000	3.57
1200	1.300	40,000	3.73
1400	1.362	45,000	3.86
1600	1.417	50,000	3.98
1800	1.468	60,000	4.21
2000	1.515	70,000	4.41
2500	1.620	80,000	4.59
3000	1.712	90,000	4.75
3500	1.793	100,000	4.90
4000	1.866	120,000	5.18
4500	1.933	140,000	5.43
5000	1.995	160,000	5.65
6000	2.110	180,000	5.85
7000	2.210	200,000	6.04
8000	2.300	220,000	6.20
9000	2.380	240,000	6.38
10000	2.460	260,000	6.54
12000	2.600	280,000	6.68
14000	2.720	300,000	6.81

### Shock Load

The load ratings for bearings are based on smooth and uniformly applied loads. When the load on the bearing is such that shock or vibration is present the bearing capacity must be increased. Use the load classification chart to adjust the actual load to the effective load that is seen by the bearing. The actual bearing load should be multiplied by the relevant factor when calculating bearing life or when determining the required BDR (Basic Dynamic Rating) for the application.

### Load Classification Chart

Load Classification	Factor
Uniform and Smooth	1.0
Light Shock	1.5
Moderate Shock	2.0
Heavy Shock	3.0

#### Example:

If a bearing is subjected to a 600 lb load under "moderate shock" conditions, a 1200 lb load should be assumed for bearing selection purposes.

### Track Capacity

In normal applications cam followers and yoke rollers operate against a track, cam or rail on a piece of machinery or equipment. The **Track Capacity** is the maximum load that a steel track of a given tensile strength will withstand without plastic deformation or brinelling of the track surface when operating with a particular size bearing. Track capacities increase with larger bearings due to the increase in contact surface. The following tables allow you to determine the track capacities for steel tracks of various hardness and tensile strengths when used with different size cam followers and yoke rollers. When using crowned bearings assume 80% of the value for track capacities due to a decrease in contact area between the track and bearing outer race.

To determine the **Track Capacity** for a particular track of given hardness or tensile strength and bearing size, multiply the **Capacity Factor** in Table 2 by the **Track Capacity** in Table 1.

#### Example:

Track Hardness = 32 Rockwell "C"

Bearing Size = 1 1/2

To determine the **Track Capacity** multiply the **Capacity Factor** in Table 2 by the **Track Capacity** in Table 1.

**Track Capacity** = .61 x 3760 lbs. = 2282 lbs

Table 1

Basic Bearing Size	Track Capacity @ 180,000 P.S.I.
1/2	515
9/16	570
5/8	710
11/16	850
3/4	1050
7/8	1190
1	1560
1 1/8	1750
1 1/4	2425
1 3/8	2650
1 1/2	3475
1 5/8	3760
1 3/4	4640
1 7/8	4960
2	6725
2 1/4	7560
2 1/2	9640
2 3/4	12560
3	13750
3 1/4	14900
3 1/2	18800
4	20600
5	36400
6	52000

Table 2

Track Tensile	Rockwell "C" Hardness	Capacity Factor
120,000	26	.45
140,000	32	.61
160,000	36	.79
180,000	40	1.00
200,000	44	1.24
220,000	47	1.50
240,000	50	1.78

**Bearing Weights (lbs)**

Bearing Size	CR Series	HR Series	YR Series
1/2	.03	.03	-
9/16	.04	-	-
5/8	.05	.05	-
11/16	.06	-	-
3/4	.08	.08	.06
7/8	.10	.10	.08
1	.17	.20	.15
1 1/8	.20	.24	.17
1 1/4	.32	.38	.24
1 3/8	.38	.44	.30
1 1/2	.55	.69	.41
1 5/8	.61	.75	.50
1 3/4	.88	1.00	.64
1 7/8	.97	1.38	.80
2	1.41	1.56	1.05
2 1/4	1.69	1.88	1.32
2 1/2	2.50	2.75	1.80
2 3/4	3.00	3.19	2.25
3	4.00	4.56	3.10
3 1/4	4.50	5.19	3.62
3 1/2	6.42	7.01	4.95
4	9.46	10.83	7.05
5	19.60	-	14.34
6	32.75	-	20.25

**Hexagonal Wrench Sizes**

Bearing Size	Hex Wrench Size
1/2	1/8
9/16	1/8
5/8	1/8
11/16	1/8
3/4	3/16
7/8	3/16
1	1/4
1 1/8	1/4
1 1/4	1/4
1 3/8	1/4
1 1/2	5/16
1 5/8	5/16
1 3/4	5/16
1 7/8	5/16
2	7/16
2 1/4	7/16
2 1/2	1/2
2 3/4	1/2
3	5/8
3 1/4	5/8
3 1/2	5/8
4	3/4
5	1
6	1

**High Temperature Applications:**

When using bearings at elevated temperatures the subsequent load ratings will be reduced. Standard bearings manufactured from SAE-52100 Bearing Steel will lose 10% of their rating when operating at 400 °F. **Smith Bearing®** specializes in manufacturing bearings from exotic alloys designed for high-strength, corrosion-resistance or elevated temperatures. The temperature chart below demonstrates the different specialty alloys that are available and the effect that temperature has on the load rating.

**Temperature Effect on % Load Rating** (approx. percentages, ref. only)

MATERIALS	Temperature °F						
	200	300	400	500	600	700	800
M-50 Tool Steel	100	100	97	96	96	95	90
M-2 Tool Steel	100	100	100	100	100	100	98
M-10 Tool Steel	100	100	100	100	100	100	97
440-C	100	95	90	86	80	72	60
SAE 52-100	100	97	90	75	50	25	15



**TOLERANCE CHART for Metric Bearings**  
**MCR-Series, MYR-Series, NUKR-Series, MUTD-Series**

**Cylindrical Roller Diameter "D"**

SIZE		TOLERANCE	
Over	Including	Maximum	Minimum
6 mm	18 mm	0	-0.008 mm
18 mm	30 mm	0	-0.009 mm
30 mm	50 mm	0	-0.010 mm
50 mm	80 mm	0	-0.013 mm
80 mm	120 mm	0	-0.015 mm

**Crowned Roller Diameter "D"**

SIZE		TOLERANCE	
Over	Including	Maximum	Minimum
6 mm	120 mm	0	-0.050 mm

**Stud Diameter "d"**

SIZE		TOLERANCE	
Over	Including	Maximum	Minimum
2 mm	6 mm	0	-0.012 mm
6 mm	10 mm	0	-0.015 mm
10 mm	18 mm	0	-0.018 mm
18 mm	30 mm	0	-0.021 mm

**Bore Diameter "d" for Yoke Rollers**

SIZE		TOLERANCE	
Over	Including	Maximum	Minimum
2 mm	17 mm	0	-0.008 mm
17 mm	30 mm	0	-0.010 mm
30 mm	50 mm	0	-0.012 mm
50 mm	80 mm	0	-0.015 mm
80 mm	120 mm	0	-0.200 mm



# Cam Followers



INCH & METRIC SIZES  
YOKE & STUD TYPE



Cam Followers & Yoke Rollers

Metric Cam Followers & Yoke Rollers

Cam Followers  
with Non-metallic Self-lubricating  
Engineered Plastic Bushing

Stainless Steel Cam Followers

Heavy Duty Double Row  
Cam Followers

**CR & CR-X**

**Regular Stud**

**Screwdriver Slot**

Regular Stud with  
Screw-Driver Slot  
Sealed or Unsealed  
X = Sealed

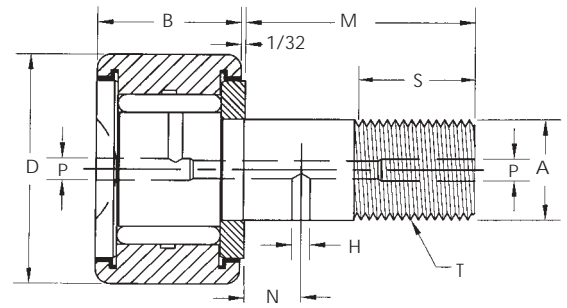

Dimensional Data (inches)

SMITH Bearing® Number		D Roller O.D. +.000 -.001	B Roller Width +.000 -.005	A Stud Dia. +.001 -.000	M Stud Length	S Eff. Thread Min.	T Thread U.N.F. Class 2A	N Oil Hole Location	H Oil Hole Dia.	P Lube Fitting Size	Min. Boss. Dia.	Recom. Bore +.0005 -.0000	Recom. Torque (lbs-in)	Basic Dynamic Rating (lbs)	Max. Static Capacity (lbs)
UNSEALED	SEALED														
CR-1/2A	CR-1/2-AX	.500	.344	.190	1/2	1/4	10-32	-	-	*1/8	19/64	.1900	20	870	720
CR-1/2	CR-1/2-X	.500	.375		5/8									970	
CR-9/16	CR-9/16-X	.5625													
CR-5/8A	CR-5/8-AX	.625	.406	.250	5/8	5/16	1/4-28	-	-	*1/8	23/64	.2500	50	1210	1250
CR-5/8	CR-5/8-X	.625	.4375		3/4									1320	
CR-11/16	CR-3/4-X	.6875													
CR-3/4	CR-3/4-X	.750	.500	.375	7/8	3/8	3/8-24	1/4	3/32	3/16	1/2	.3750	120	2140	2260
CR-7/8	CR-7/8-X	.875													
CR-1	CR-1-X	1.000	.625	.4375	1	1/2	7/16-20	1/4	3/32	3/16	5/8	.4375	350	3030	3100
CR-1 1/8	CR-1 1/8-X	1.125													
CR-1 1/4	CR-1 1/4-X	1.250	.750	.500	1 1/4	5/8	1/2-20	5/16	3/32	3/16	3/4	.5000	500	4470	4300
CR-1 3/8	CR-1 3/8-X	1.375													
CR-1 1/2	CR-1 1/2-X	1.500	.875	.625	1 1/2	3/4	5/8-18	3/8	3/32	3/16	57/64	.6250	1000	5560	5730
CR-1 5/8	CR-1 5/8-X	1.625													
CR-1 3/4	CR-1 3/4-X	1.750	1.000	.750	1 3/4	7/8	3/4-16	7/16	3/32	3/16	1 3/64	.7500	2000	7870	7950
CR-1 7/8	CR-1 7/8-X	1.875													
CR-2	CR-2-X	2.000	1.250	.875	2	1	7/8-14	1/2	5/32	3/16	1 13/64	.8750	2200	10370	10700
CR-2 1/4	CR-2 1/4-X	2.250													
CR-2 1/2	CR-2 1/2-X	2.500	1.500	1.000	2 1/4	1 1/8	1-14	9/16	5/32	3/16	1 5/16	1.0000	3000	15280	16650
CR-2 3/4	CR-2 3/4-X	2.750													
CR-3	CR-3-X	3.000	1.750	1.250	2 1/2	1 1/4	1 1/4-12	5/8	1/4	1/4	1 3/4	1.2500	5000	20200	25200
CR-3 1/4	CR-3 1/4-X	3.250													
CR-3 1/2	CR-3 1/2-X	3.500	2.000	1.375	2 3/4	1 3/8	1 3/8-12	11/16	1/4	1/4	2	1.3750	6000	29660	31800
CR-4	CR-4-X	4.000	2.225	1.500	3 1/2	1 1/2	1 1/2-12	3/4	1/4	1/4	2 1/4	1.5000	7000	35980	45100
	CR-5-XB	Available in Hex Hole Configuration only.													
	CR-6-XB														

\* Relubricate through head end only.

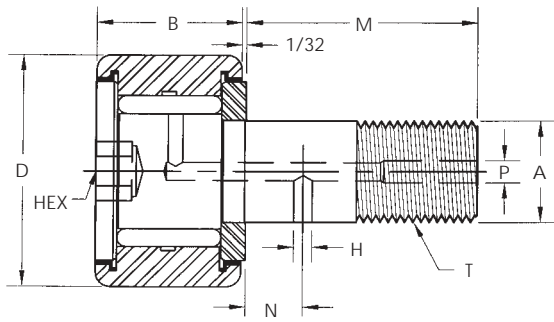

**CR-B & CR-XB**

**Regular Stud**

**Hex-Drive Socket**

Regular Stud  
with Hex-Drive Socket  
Sealed or Unsealed  
X = Sealed

Dimensional Data (inches)

SMITH Bearing® Number		D Roller O.D. +.000 -.001	B Roller Width +.000 -.005	A Stud Dia. +.001 -.000	M Stud Length	S Eff. Thread Min.	T Thread U.N.F. Class 2A	HEX Size	N Oil Hole Location	H Oil Hole Dia.	P Lube Fitting Size ▲	Min Boss. Dia.	Recom. Bore +.0005 -.0000	Recom. Torque (lbs-in)	Basic Dynamic Rating (lbs)	Max Static Capacity (lbs)
UNSEALED	SEALED															
CR-1/2-B	CR-1/2-XB	.500	.375	.190	5/8	1/4	10-32	1/8	-	-	▲▲	19/64	.1900	20	970	720
CR-5/8-B	CR-5/8-XB	.625	.4375	.250	3/4	5/16	1/4-28	1/8	-	-	▲▲	23/64	.2500	50	1320	1250
CR-3/4-B	CR-3/4-XB	.750	.500	.375	7/8	3/8	3/8-24	3/16	1/4	3/32	3/16	1/2	.3750	120	2140	2200
CR-7/8-B	CR-7/8-XB	.875														
CR-1-B	CR-1-XB	1.000	.625	.4375	1	1/2	7/16-20	1/4	1/4	3/32	3/16	5/8	.4375	350	3030	3100
CR-1 1/8-B	CR-1 1/8-XB	1.125														
CR-1 1/4-B	CR-1 1/4-XB	1.250	.750	.500	1 1/4	5/8	1/2-20	1/4	5/16	3/32	3/16	3/4	.5000	500	4470	4300
CR-1 3/8-B	CR-1 3/8-XB	1.375														
CR-1 1/2-B	CR-1 1/2-XB	1.500	.875	.625	1 1/2	3/4	5/8-18	5/16	3/8	3/32	3/16	57/64	.6250	1000	5560	5730
CR-1 5/8-B	CR-1 5/8-XB	1.625														
CR-1 3/4-B	CR-1 3/4-XB	1.750	1.000	.750	1 3/4	7/8	3/4-16	5/16	7/16	3/32	3/16	1 3/64	.7500	2000	7870	7950
CR-1 7/8-B	CR-1 7/8-XB	1.875														
CR-2-B	CR-2-XB	2.000	1.250	.875	2	1	7/8-14	7/16	1/2	5/32	3/16	1 13/64	.8750	2200	10370	10700
CR-2 1/4-B	CR-2 1/4-XB	2.250														
CR-2 1/2-B	CR-2 1/2-XB	2.500	1.500	1.000	2 1/4	1 1/8	1-14	1/2	9/16	5/32	3/16	1 5/16	1.0000	3000	15280	16650
CR-2 3/4-B	CR-2 3/4-XB	2.750														
CR-3-B	CR-3-XB	3.000	1.750	1.250	2 1/2	1 1/4	1 1/4-12	5/8	5/8	1/4	1/4	1 3/4	1.2500	5000	20200	25260
CR-3 1/4-B	CR-3 1/4-XB	3.250														
CR-3 1/2-B	CR-3 1/2-XB	3.500	2.000	1.375	2 3/4	1 3/8	1 3/8-12	5/8	11/16	1/4	1/4	2	1.3750	6000	24660	31800
CR-4-B	CR-4-XB	4.000	2.250	1.500	3 1/2	1 1/2	1 1/2-12	3/4	3/4	1/4	1/4	2 1/4	1.5000	7000	35980	45100
	CR-5-XB	3.500	2.750	2.000	5 1/16	2 9/16	2-12	1	-	-	1/4	3	2.0000	7500	49750	56900
	CR-6-XB	4.000	3.250	2.500	6	3	2 1/2-12	1	-	-	1/4	3 1/2	2.5000	7500	71400	94000

▲ Relubricate through threaded end only.  
▲▲ Cannot be relubricated.

**CR-XBE**

**Eccentric Stud**

**Hex-Drive Socket**

Eccentric Stud  
with Hex-Drive Socket  
Sealed

X = Sealed

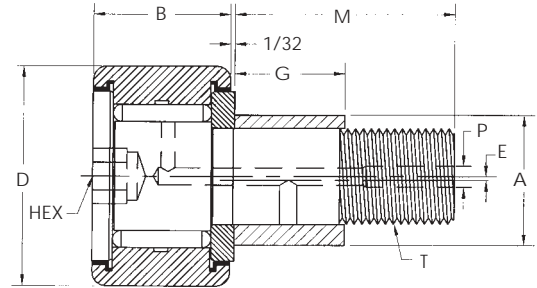

Dimensional Data (inches)

SMITH Bearing® Number	D Roller O.D. + .000 - .001	B Roller Width + .000 - .005	A Eccentric Bushing O.D. ± .001	G Eccentric Bushing † Length + .000 - .010	E Eccentricity ± .005	M Stud Length Class 2A	T Thread U.N.F.	HEX Size	P Lube Fitting ▲	Basic Dynamic Rating (lbs)
SEALED										
CR-1/2-XBE	.500	.375	.250	.375	.010	5/8	10-32	1/8	▲▲	970
CR-5/8-XBE	.625	.437	.375	.437	.015	3/4	1/4-28	1/8	▲▲	1320
CR-3/4-XBE	.750	.500	.500	.500	.030	7/8	3/8-24	3/16	3/16	2140
CR-7/8-XBE	.875									
CR-1-XBE	1.000	.625	.625	.500	.030	1	7/16-20	1/4	3/16	3030
CR-1 1/8-XBE	1.125									
CR-1 1/4-XBE	1.250	.750	.687	.625	.030	1 1/4	1/2-20	1/4	3/16	4470
CR-1 3/8-XBE	1.375									
CR-1 1/2-XBE	1.500	.875	.875	.750	.030	1 1/2	5/8-18	5/16	3/16	5560
CR-1 5/8-XBE	1.625									
CR-1 3/4-XBE	1.750	1.000	1.000	.875	.030	1 3/4	3/4-16	5/16	3/16	7870
CR-1 7/8-XBE	1.875									
CR-2-XBE	2.000	1.250	1.187	1.000	.030	2	7/8-14	7/16	3/16	10370
CR-2 1/4-XBE	2.250									
CR-2 1/2-XBE	2.500	1.500	1.375	1.125	.030	2 1/4	1-14	1/2	3/16	15280
CR-2 3/4-XBE	2.750									

▲ Relubricate through threaded end only.

▲▲ Cannot be relubricated.

† Housing thickness should be a minimum of .010 longer than bushing length to provide positive clamping.

NOTE: Also available in Screwdriver version.

**Adjustment for More Precise Positioning of Cam Followers**

Hex-drive socket Cam Followers with a press fit eccentric bushing sleeve provide correct alignment and adjustment without costly preparation of close tolerance mounting holes and members. They eliminate problems of clearances, preloading and wear compensation and assure load sharing in multiple cam follower applications. The Hex-drive socket allows positive torque for locking and adjustment. A lock nut provides adequate clamping to hold bearing in desired position in most applications. Where more positive positioning or permanent locking is required, drill through the housing into the bushing and stud for doweling or set-screw.

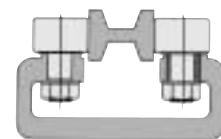

Control of Clearance and Adjustment for Wear

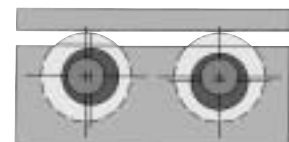

In-line Adjustment Allows Greater Location Tolerance for Mounting Holes

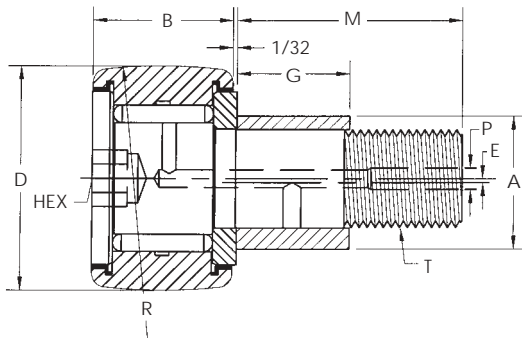

**CR-XBEC**  
**Crowned • Eccentric Stud**  
 Hex-Drive Socket

Eccentric Stud with  
 Crowned Outer Race  
 Hex-Drive Socket  
 Sealed  
 X = Sealed

Dimensional Data (inches)

SMITH Bearing® Number	D Roller O.D. + .000 - .001	B Roller Width + .000 - .005	A Eccentric Bushing O.D. ± .001	G Eccentric Bushing † Length + .000 - .010	E Eccentricity ± .005	M Stud Length	T Thread U.N.F. Class 2A	HEX Size	P Lube Fitting Size ▲	Basic Dynamic Rating (lbs)	R Crown Radius (Inches)
SEALED											
CR-1/2-XBEC	.500	.375	.250	.375	.010	5/8	10-32	1/8	▲▲	970	7
CR-5/8-XBEC	.625	.4375	.375	.437	.015	3/4	1/4-28	1/8	▲▲	1320	8
CR-3/4-XBEC	.750	.500	.500	.500	.030	7/8	3/8-24	3/16	3/16	2140	10
CR-7/8-XBEC	.875										
CR-1-XBEC	1.000	.625	.625	.500	.030	1	7/16-20	1/4	3/16	3030	12
CR-1 1/8-XBEC	1.125										
CR-1 1/4-XBEC	1.250	.750	.687	.625	.030	1 1/4	1/2-20	1/4	3/16	4470	14
CR-1 3/8-XBEC	1.375										
CR-1 1/2-XBEC	1.500	.875	.875	.750	.030	1 1/2	5/8-18	5/16	3/16	5560	20
CR-1 5/8-XBEC	1.625										
CR-1 3/4-XBEC	1.750	1.000	1.000	.875	.030	1 3/4	3/4-16	5/16	3/16	7870	20
CR-1 7/8-XBEC	1.875										
CR-2-XBEC	2.000	1.250	1.187	1.000	.030	2	7/8-14	7/16	3/16	10370	24
CR-2 1/4-XBEC	2.250										
CR-2 1/2-XBEC	2.500	1.500	1.375	1.125	.030	2 1/4	1-14	1/2	3/16	15280	30
CR-2 3/4-XBEC	2.750										

▲ Relubricate through threaded end only.

▲▲ Cannot be relubricated.

† Housing thickness should be a minimum of .010 longer than bushing length to provide positive clamping.

NOTE: Also available in Screwdriver version.

**Adjustment for More Precise Positioning of Cam Followers**

Hex-drive Socket Cam Followers with a press fit eccentric bushing sleeve provide correct alignment and adjustment without costly preparation of close tolerance mounting holes and members. They eliminate problems of clearances, preloading and wear compensation and assure load sharing in multiple cam follower applications. The Hex-drive socket allows positive torque for locking and adjustment. A lock nut provides adequate clamping to hold bearing in desired position in most applications. Where more positive positioning or permanent locking is required, drill through the housing into the bushing and stud for doweling or set-screw.

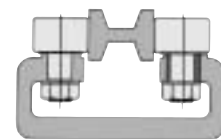

Control of Clearance and Adjustment for Wear

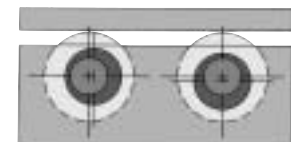

In-line Adjustment Allows Greater Location Tolerance for Mounting Holes

## HR & HR-X

### Heavy Stud

#### Screwdriver Slot

Heavy Stud with  
Screw-Driver Slot  
Sealed or Unsealed  
X = Sealed

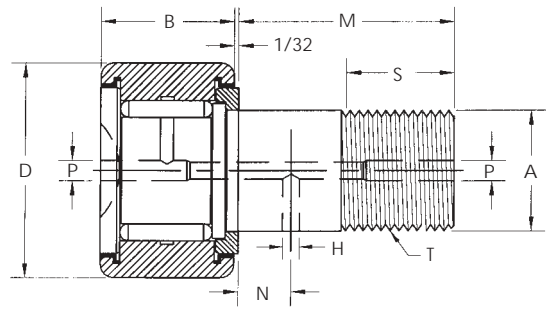

Dimensional Data (inches)

SMITH Bearing® Number		D Roller O.D. +.000 -.001	B Roller Width +.000 -.005	A Stud Dia. +.001 -.000	M Stud Length	S Eff. Thread Min.	T Thread U.N.F. Class 2A	N Oil Hole Location	H Oil Hole Dia.	P Lube Fitting Size	Min Boss. Dia.	Recom. Bore +.0005 -.0000	Recom. Torque (lbs-in)	Basic Dynamic Rating (lbs)	Max Static Capacity (lbs)
UNSEALED	SEALED														
HR-1/2	HR-1/2-X	.500	.375	.250	5/8	1/4	1/4-28	-	-	*1/8	19/64	.2500	50	970	1590
HR-5/8	HR-5/8-X	.625	.437	.3125	3/4	5/16	5/16-24	-	-	*1/8	23/64	.3125	75	1210	2500
HR-3/4	HR-3/4-X	.750	.500	.4375	7/8	3/8	7/16-20	1/4	3/32	3/16	1/2	.4375	300	2140	4150
HR-7/8	HR-7/8-X	.875													
HR-1	HR-1-X	1.000	.625	.625	1	1/2	5/8-18	1/4	3/32	3/16	3/4	.6250	500	2850	6200
HR-1 1/8	HR-1 1/8-X	1.125													
HR-1 1/4	HR-1 1/4-X	1.250	.750	.750	1 1/4	5/8	3/4-16	5/16	3/32	3/16	7/8	.7500	1000	4060	8600
HR-1 3/8	HR-1 3/8-X	1.375													
HR-1 1/2	HR-1 1/2-X	1.500	.875	.875	1 1/2	3/4	7/8-14	3/8	3/32	3/16	15/16	.8750	2000	5330	11300
HR-1 5/8	HR-1 5/8-X	1.625													
HR-1 3/4	HR-1 3/4-X	1.750	1.000	1.000	1 3/4	7/8	1-14	7/16	3/32	3/16	1 3/32	1.0000	2500	7600	15870
HR-1 7/8	HR-1 7/8-X	1.875													
HR-2	HR-2-X	2.000	1.250	1.125	2	1	1 1/8-12	1/2	5/32	3/16	1 7/32	1.1250	3000	10050	22000
HR-2 1/4	HR-2 1/4-X	2.250													
HR-2 1/2	HR-2 1/2-X	2.500	1.500	1.250	2 1/4	1 1/8	1 1/4-12	9/16	5/32	3/16	1 5/16	1.2500	4000	15280	33000
HR-2 3/4	HR-2 3/4-X	2.750													
HR-3	HR-3-X	3.000	1.750	1.500	2 1/2	1 1/4	1 1/2-12	5/8	5/32	1/4	1 3/4	1.5000	5000	20200	49900
HR-3 1/4	HR-3 1/4-X	3.250													
HR-3 1/2	HR-3 1/2-X	3.500	2.000	1.750	2 3/4	1 3/8	1 3/4-12	11/16	5/32	1/4	1 15/16	1.7500	6000	29660	63300
HR-4	HR-4-X	4.000	2.250	2.000	3 1/2	1 1/2	2-12	3/4	5/32	1/4	2 1/4	2.0000	8000	35980	90000

\* Relubricate through head end only.

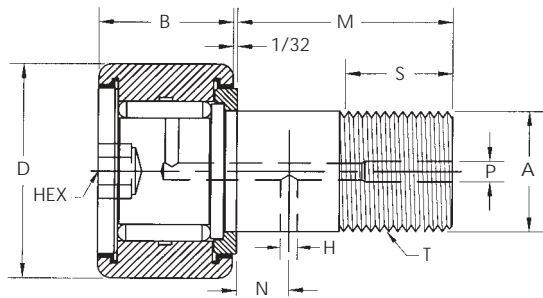

**HR-B & HR-XB**

**Heavy Stud**

Hex-Drive Socket

Heavy Stud with Hex-Drive Socket Sealed or Unsealed  
X = Sealed

Dimensional Data (inches)

SMITH Bearing® Number		D Roller O.D. +.000 -.001	B Roller Width +.000 -.005	A Stud Dia. +.001 -.000	M Stud Length	S Eff. Thread Min.	T Thread U.N.F. Class 2A	HEX Size	N Oil Hole Location	H Oil Hole Dia.	P Lube Fitting Size ▲	Min Boss. Dia.	Recom. Bore +.0005 -.0000	Recom. Torque (lbs-in)	Basic Dynamic Rating (lbs)	Max Static Capacity (lbs)
UNSEALED	SEALED															
HR-1/2-B	HR-1/2-XB	.500	.375	.250	5/8	1/4	1/4-28	1/8	-	-	▲▲	19/64	.2500	50	970	1590
HR-5/8-B	HR-5/8-XB	.625	.437	.3125	3/4	5/16	5/16-24	1/8	-	-	▲▲	23/64	.3125	75	1210	2500
HR-3/4-B	HR-3/4-XB	.750	.500	.4375	7/8	3/8	7/16-20	3/16	1/4	3/32	3/16	1/2	.4375	300	2140	4150
HR-7/8-B	HR-7/8-XB	.875														
HR-1-B	HR-1-XB	1.000	.625	.625	1	1/2	5/8-18	1/4	1/4	3/32	3/16	3/4	.6250	500	2850	6200
HR-1 1/8-B	HR-1 1/8-XB	1.125														
HR-1 1/4-B	HR-1 1/4-XB	1.250	.750	.750	1 1/4	5/8	3/4-16	1/4	5/16	3/32	3/16	7/8	.7500	1000	4060	8600
HR-1 3/8-B	HR-1 3/8-XB	1.375														
HR-1 1/2-B	HR-1 1/2-XB	1.500	.875	.875	1 1/2	3/4	7/8-14	5/16	3/8	3/32	3/16	15/16	.8750	2000	5330	11300
HR-1 5/8-B	HR-1 5/8-XB	1.625														
HR-1 3/4-B	HR-1 3/4-XB	1.750	1.000	1.000	1 3/4	7/8	1-14	5/16	7/16	3/32	3/16	1 3/32	1.0000	2500	7600	15870
HR-1 7/8-B	HR-1 7/8-XB	1.875														
HR-2-B	HR-2-XB	2.000	1.250	1.125	2	1	1 1/8-12	7/16	1/2	5/32	3/16	1 7/32	1.1250	3000	10050	22000
HR-2 1/4-B	HR-2 1/4-XB	2.250														
HR-2 1/2-B	HR-2 1/2-XB	2.500	1.500	1.250	2 1/4	1 1/8	1 1/4-12	1/2	9/16	5/32	3/16	1 5/16	1.2500	4000	15280	33000
HR-2 3/4-B	HR-2 3/4-XB	2.750														
HR-3-B	HR-3-XB	3.000	1.750	1.500	2 1/2	1 1/4	1 1/2-12	5/8	5/8	5/32	1/4	1 3/4	1.5000	5000	20200	49900
HR-3 1/4-B	HR-3 1/4-XB	3.250														
HR-3 1/2-B	HR-3 1/2-XB	3.500	2.000	1.750	2 3/4	1 3/8	1 3/4-12	5/8	11/16	5/32	1/4	1 15/16	1.7500	6000	29660	63300
HR-4-B	HR-4-XB	4.000	2.250	2.000	3 1/2	1 1/2	2-12	3/4	3/4	5/32	1/4	2 1/4	2.0000	8000	35980	90000

▲ Relubricate through threaded end only.

▲▲ Cannot be relubricated.



## YR & YR-X

### Yoke Type

for Shaft Mounting  
Sealed or Unsealed  
X = Sealed

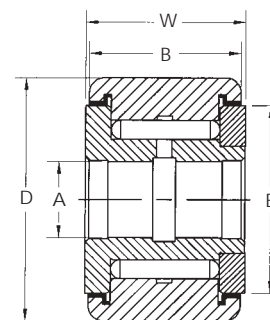

Dimensional Data (inches)

SMITH Bearing® Number		D Roller O.D. +.000 -.001	A Bore Nominal	Tolerance	B Roller Width +.000 -.005	W Overall Width +.005 -.010	E Min Clamping Dia.	Recommended Shaft Dia.				Basic Dynamic Rating (lbs)	Max Static Capacity (lbs)
UNSEALED	SEALED							Slip Fit		Press Fit			
								Max.	Min.	Max.	Min.		
YR-3/4	YR-3/4-X	.750	.2500	+0.0002 -0.0004	.500	.5625	1/2	.2497	.2493	.2505	.2501	2140	4170
YR-7/8	YR-7/8-X	.875											
YR-1	YR-1-X	1.000	.3125		.625	.6875	5/8	.3122	.3118	.3130	.3126	3030	6200
YR-1 1/8	YR-1 1/8-X	1.125											
YR-1 1/4	YR-1 1/4-X	1.250	.3750		.750	.8125	3/4	.3747	.3743	.3755	.3751	4470	8600
YR-1 3/8	YR-1 3/8-X	1.375											
YR-1 1/2	YR-1 1/2-X	1.500	.4375		.875	.9375	57/64	.4372	.4368	.4380	.4376	5560	11300
YR-1 5/8	YR-1 5/8-X	1.625											
YR-1 3/4	YR-1 3/4-X	1.750	.5000		1.000	1.0625	1 3/64	.4997	.4993	.5007	.5003	7870	15870
YR-1 7/8	YR-1 7/8-X	1.875											
YR-2	YR-2-X	2.000	.6250		1.250	1.3125	1 13/64	.6247	.6243	.6257	.6253	10370	22000
YR-2 1/4	YR-2 1/4-X	2.250											
YR-2 1/2	YR-2 1/2-X	2.500	.7500	1.500	1.5625	1 5/16	.7497	.7493	.7507	.7503	15280	33000	
YR-2 3/4	YR-2 3/4-X	2.750											
YR-3	YR-3-X	3.000	1.0000	1.750	1.8125	1 3/4	.9996	.9992	1.0008	1.0003	20200	49900	
YR-3 1/4	YR-3 1/4-X	3.250											
YR-3 1/2	YR-3 1/2-X	3.500	1.1250	+0.0001 -0.0005	2.000	2.0625	2	1.1246	1.1241	1.1258	1.1253	24660	63300
YR-4	YR-4-X	4.000	1.2500		2.250	2.3125	2 1/4	1.2496	1.2491	1.2508	1.2503	35980	90000
	YR-5-X	5.000	1.7500		2.750	2.8750	3	1.7496	1.7491	1.7508	1.7503	49750	136000
	YR-6-X	6.000	2.2500		3.250	3.3750	3 1/2	2.2496	2.2491	2.2508	2.2503	71400	162000

# Crowned Cam Followers

INCH SIZES  
YOKE & STUD TYPE

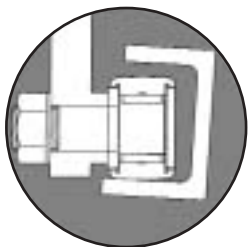

#### CROWNED BEARINGS

##### Add Suffix "C"

are recommended where the track or cam may impart excessive thrust loading on the bearing due to misalignment.

Edge Loading of full complement needle bearings causes skewing and end thrusting which contribute to premature bearing failure. In situations where it is impractical or too costly to provide for perfect alignment, crowned bearing O.D.'s provide compensation for misalignment between the cam follower and the surface of a slanted track or cam. The radius also eliminates skidding and thrusting typically found when the bearing is on contact with a flat or circular cam. Bearing life will be increased in those problem applications where standard flat bearing surfaces have proven troublesome.

**CR-C & CR-XC**

**Crowned • Regular Stud**

**Screwdriver Slot**

Regular Stud  
with Crowned Outer Race  
Screw-Driver Slot  
Sealed or Unsealed  
X = Sealed

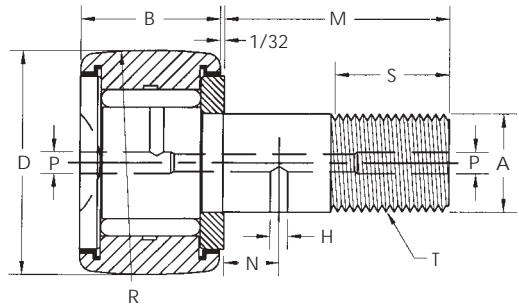

Dimensional Data (inches)

SMITH Bearing® Number		D Roller O.D. +.000 -.001	B Roller Width +.000 -.005	A Stud Dia. +.001 -.000	M Stud Length	S Eff. Thread Min.	T Thread U.N.F. Class 2A	N Oil Hole Location	H Oil Hole Dia.	P Lube Fitting Size	Min. Boss. Dia.	Recom. Bore +.0005 -.0000	Recom. Torque (lbs-in)	Basic Dynamic Rating (lbs)	Max Static Capacity (lbs)	R Crown Radius (Inches)
UNSEALED	SEALED															
CR-1/2A-C	CR-1/2A-XC	.500	.3440		1/2									870		
CR-1/2-C	CR-1/2-XC	.500	.3750	.190	5/8	1/4	10-32	-	-	*1/8	19/64	.1900	20	970	720	7
CR-9/16-C	CR-9/16-XC	.5625														
CR-5/8A-C	CR-5/8A-XC	.625	.4060		5/8									1210		
CR-5/8-C	CR-5/8-XC	.625	.4375	.250	3/4	5/16	1/4-28	-	-	*1/8	23/64	.2500	50	1320	1250	8
CR-11/16-C	CR-11/16-XC	.6875														
CR-3/4-C	CR-3/4-XC	.750	.5000	.375	7/8	3/8	3/8-24	1/4	3/32	3/16	1/2	.3750	120	2140	2200	10
CR-7/8-C	CR-7/8-XC	.875														
CR-1-C	CR-1-XC	1.000	.6250	.4375	1	1/2	7/16-20	1/4	3/32	3/16	5/8	.4375	350	3030	3100	12
CR-1 1/8-C	CR-1 1/8-XC	1.125														
CR-1 1/4-C	CR-1 1/4-XC	1.250	.7500	.500	1-1/4	5/8	1/2-20	5/16	3/32	3/16	3/4	.5000	500	4470	4300	14
CR-1 3/8-C	CR-1 3/8-XC	1.375														
CR-1 1/2-C	CR-1 1/2-XC	1.500	.8750	.625	1-1/2	3/4	5/8-18	3/8	3/32	3/16	57/64	.6250	1000	5560	5730	20
CR-1 5/8-C	CR-1 5/8-XC	1.625														
CR-1 3/4-C	CR-1 3/4-XC	1.750	1.0000	.750	1 3/4	7/8	3/4-16	7/16	3/32	3/16	1 3/64	.7500	2000	7870	7950	20
CR-1 7/8-C	CR-1 7/8-XC	1.875														
CR-2-C	CR-2-XC	2.000	1.2500	.875	2	1	7/8-14	1/2	5/32	3/16	1 13/64	.8750	2200	10370	10700	24
CR-2 1/4-C	CR-2 1/4-XC	2.250														
CR-2 1/2-C	CR-2 1/2-XC	2.500	1.5000	1.000	2 1/4	1 1/8	1-14	9/16	5/32	3/16	1 5/16	1.0000	3000	15280	16650	30
CR-2 3/4-C	CR-2 3/4-XC	2.750														
CR-3-C	CR-3-XC	3.000	1.7500	1.250	2 1/2	1 1/4	1 1/4-12	5/8	1/4	1/4	1 3/4	1.2500	5000	20200	25200	30
CR-3 1/4-C	CR-3 1/4-XC	3.250														
CR-3 1/2-C	CR-3 1/2-XC	3.500	2.0000	1.375	2 3/4	1 3/8	1 3/8-12	11/16	1/4	1/4	2	1.3750	6000	29660	31800	30
CR-4-C	CR-4-XC	4.000	2.2500	1.500	3 1/2	1 1/2	1 1/2-12	3/4	1/4	1/4	2 1/4	1.5000	7000	35980	45100	30
	CR-5-XBC	Available only in Hex Hole Configuration.														
	CR-6-XBC															

\* Relubricate through head end only.

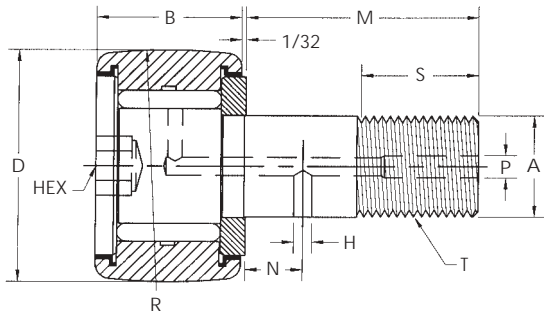

**CR-BC & CR-XBC**

**Crowned • Regular Stud**

Hex-Drive Socket

Regular Stud  
with Crowned Outer Race  
Hex-Drive Socket  
Sealed or Unsealed  
X = Sealed

For Eccentric Sleeve Add Suffix "E"  
Example: **CR-XBEC**. See Page 15.

Dimensional Data (inches)

SMITH Bearing® Number		D Roller O.D. +.000 -.001	B Roller Width +.000 -.005	A Stud Dia. +.001 -.000	M Stud Length	S Eff. Thread Min.	T Thread U.N.F. Class 2A	HEX Size	N Oil Hole Location	H Oil Hole Dia.	P Lube Fitting Size ▲	Min Boss. Dia.	Recom. Bore +.0005 -.0000	Recom. Torque (lbs-in)	Basic Dynamic Rating (lbs)	Max Static Capacity (lbs)	R Crown Radius (Inches)
UNSEALED	SEALED																
CR-1/2-BC	CR-1/2-XBC	.500	.3750	.190	5/8	1/4	10-32	1/8	-	-	▲▲	19/64	.1900	20	970	720	7
CR-5/8-BC	CR-5/8-XBC	.500	.4375	.250	3/4	5/16	1/4-28	1/8	-	-	▲▲	23/64	.2500	50	1320	1250	8
CR-3/4-BC	CR-3/4-XBC	.750	.5000	.3750	7/8	3/8	3/8-24	3/16	1/4	3/32	3/16	1/2	.3750	120	2140	3200	10
CR-7/8-BC	CR-7/8-XBC	.875															
CR-1-BC	CR-1-XBC	1.000	.6250	.4375	1	1/2	7/16-20	1/4	1/4	3/32	3/16	5/8	.4375	350	3030	3100	12
CR-1 1/8-BC	CR-1 1/8-XBC	1.125															
CR-1 1/4-BC	CR-1 1/4-XBC	1.250	.7500	.5000	1 1/4	5/8	1/2-20	1/4	5/16	3/32	3/16	3/4	.5000	500	4470	4300	14
CR-1 3/8-BC	CR-1 3/8-XBC	1.375															
CR-1 1/2-BC	CR-1 1/2-XBC	1.500	.8750	.6250	1 1/2	3/4	5/8-18	5/16	3/8	3/32	3/16	57/64	.6250	1000	5560	5730	20
CR-1 5/8-BC	CR-1 5/8-XBC	1.625															
CR-1 3/4-BC	CR-1 3/4-XBC	1.750	1.0000	.7500	1 3/4	7/8	3/4-16	5/16	7/16	3/32	3/16	1 3/64	.7500	2000	7870	7950	20
CR-1 7/8-BC	CR-1 7/8-XBC	1.875															
CR-2-BC	CR-2-XBC	2.000	1.2500	.8750	2	1	7/8-14	7/16	1/2	5/32	3/16	1 13/64	.8750	2200	10370	10700	24
CR-2 1/4-BC	CR-2 1/4-XBC	2.250															
CR-2 1/2-BC	CR-2 1/2-XBC	2.500	1.5000	1.0000	2 1/4	1 1/8	1-14	1/2	9/16	5/32	3/16	1 5/16	1.0000	3000	15280	16650	30
CR-2 3/4-BC	CR-2 3/4-XBC	2.750															
CR-3-BC	CR-3-XBC	3.000	1.7500	1.2500	2 1/2	1 1/4	1 1/4-12	5/8	5/8	1/4	1/4	1 3/4	1.2500	5000	20200	25260	30
CR-3 1/4-BC	CR-3 1/4-XBC	3.250															
CR-3 1/2-BC	CR-3 1/2-XBC	3.500	2.0000	1.3750	2 3/4	1 3/8	1 3/8-12	5/8	11/16	1/4	1/4	2	1.3750	6000	29660	31800	30
CR-4-BC	CR-4-XBC	4.000	2.2500	1.5000	3 1/2	1 1/2	1 1/2-12	3/4	3/4	1/4	1/4	2 1/4	1.5000	7000	35980	45100	30
CR-5-BC	CR-5-XBC	5.000	2.7500	2.0000	5 1/16	2 9/16	2-12	1	-	-	1/4 NPT	3	2.0000	7500	49750	56900	48
CR-6-BC	CR-6-XBC	6.000	3.2500	2.2500	6	3	2 1/2-12	1	-	-	1/4 NPT	3 1/2	2.5000	7500	71400	94000	56

▲ Relubricate through threaded end only.

▲▲ Cannot be relubricated.

## HR-C & HR-XC

### Crowned • Heavy Stud

#### Screwdriver Slot

Heavy Stud  
with Crowned Outer Race  
Screw-Driver Slot  
Sealed or Unsealed  
X = Sealed

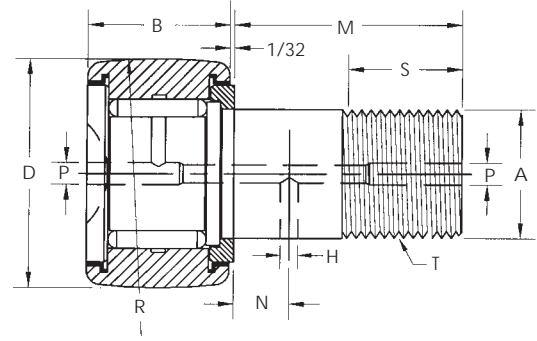

Dimensional Data (inches)

SMITH Bearing® Number		D Roller O.D. +.000 -.001	B Roller Width +.000 -.005	A Stud Dia. +.001 -.000	M Stud Length	S Eff. Thread Min.	T Thread U.N.F. Class 2A	N Oil Hole Location	H Oil Hole Dia.	P Lube Fitting Size	Min. Boss Dia.	Recom. Bore +.0005 -.0000	Recom. Torque (lbs-in)	Basic Dynamic Rating (lbs)	Max Static Capacity (lbs)	R Radius Crown (Inches)
UNSEALED	SEALED															
HR-1/2-C	HR-1/2-XC	.500	.375	.250	5/8	1/4	1/4-28	-	-	*1/8	19/64	.2500	50	970	1590	7
HR-5/8-C	HR-5/8-XC	.625	.437	.3125	3/4	5/16	5/16-24	-	-	*1/8	23/64	.3125	75	1210	2500	8
HR-3/4-C	HR-3/4-XC	.750	.500	.4375	7/8	3/8	7/16-20	1/4	3/32	3/16	1/2	.4375	300	2140	4150	10
HR-7/8-C	HR-7/8-XC	.875														
HR-1-C	HR-1-XC	1.000	.625	.625	1	1/2	5/8-18	1/4	3/32	3/16	3/4	.6250	500	2850	6200	12
HR-1 1/8-C	HR-1 1/8-XC	1.125														
HR-1 1/4-C	HR-1 1/4-XC	1.250	.750	.750	1 1/4	5/8	3/4-16	5/16	3/32	3/16	7/8	.7500	1000	4060	8690	14
HR-1 3/8-C	HR-1 3/8-XC	1.375														
HR-1 1/2-C	HR-1 1/2-XC	1.500	.875	.875	1 1/2	3/4	7/8-14	3/8	3/32	3/16	15/16	.8750	2000	5330	11300	20
HR-1 5/8-C	HR-1 5/8-XC	1.625														
HR-1 3/4-C	HR-1 3/4-XC	1.750	1.000	1.000	1 3/4	7/8	1-14	7/16	3/32	3/16	1 3/32	1.000	2500	7600	15870	20
HR-1 7/8-C	HR-1 7/8-XC	1.875														
HR-2-C	HR-2-XC	2.000	1.250	1.125	2	1	1 1/8-12	1/2	5/32	3/16	1 7/32	1.1250	3000	10050	22000	24
HR-2 1/4-C	HR-2 1/4-XC	2.250														
HR-2 1/2-C	HR-2 1/2-XC	2.500	1.500	1.250	2 1/4	1 1/8	1 1/4-12	9/16	5/32	3/16	1 5/16	1.2500	4000	15280	33000	30
HR-2 3/4-C	HR-2 3/4-XC	2.750														
HR-3-C	HR-3-XC	3.000	1.750	1.500	2 1/2	1 1/4	1 1/2-12	5/8	5/32	1/4	1 3/4	1.5000	5000	20200	49900	30
HR-3 1/4-C	HR-3 1/4-XC	3.250														
HR-3 1/2-C	HR-3 1/2-XC	3.500	2.000	1.750	2 3/4	1 3/8	1 3/4-12	11/16	5/32	1/4	1 15/16	1.7500	6000	29660	63300	30
HR-4-C	HR-4-XC	4.000	2.250	2.000	3 1/2	1 1/2	2-12	3/4	5/32	1/4	2 1/4	2.0000	8000	35980	90000	30

\* Cannot be relubricated through threaded end.

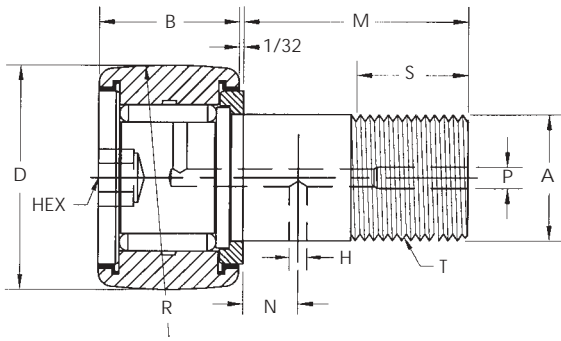

**HR-BC & HR-XBC**

**Crowned • Heavy Stud**

Hex-Drive Socket

Heavy Stud  
with Crowned Outer Race  
Hex-Drive Socket  
Sealed or Unsealed  
X = Sealed

Dimensional Data (inches)

SMITH Bearing® Number		D Roller O.D. +.000 -.001	B Roller Width +.000 -.005	A Stud Dia. +.001 -.000	M Stud Length	S Eff. Thread Min.	T Thread U.N.F. Class 2A	HEX Size	N Oil Hole Location	H Oil Hole Dia.	P Lube Fitting Size ▲	Min Boss. Dia.	Recom. Bore +.0005 -.0000	Recom. Torque (lbs-in)	Basic Dynamic Rating (lbs)	Max Static Capacity (lbs)	R Crown Radius (Inches)
UNSEALED	SEALED																
HR-1/2-BC	HR-1/2-XBC	.500	.375	.2500	5/8	1/4	1/4-28	1/8	-	-	▲▲	19/64	.2500	50	970	1590	7
HR-5/8-BC	HR-5/8-XBC	.625	.437	.3125	3/4	5/16	5/16-24	1/8	-	-	▲▲	23/64	.3125	75	1210	2500	8
HR-3/4-BC	HR-3/4-XBC	.750	.500	.4375	7/8	3/8	7/16-20	3/16	1/4	3/32	3/16	1/2	.4375	300	2140	4150	10
HR-7/8-BC	HR-7/8-XBC	.875															
HR-1-BC	HR-1-XBC	1.000	.625	.6250	1	1/2	5/8-18	1/4	1/4	3/32	3/16	3/4	.6250	500	2850	6200	12
HR-1 1/8-BC	HR-1 1/8-XBC	1.125															
HR-1 1/4-BC	HR-1 1/4-XBC	1.250	.750	.7500	1 1/4	5/8	3/4-16	1/4	5/16	3/32	3/16	7/8	.7500	1000	4060	8600	14
HR-1 3/8-BC	HR-1 3/8-XBC	1.375															
HR-1 1/2-BC	HR-1 1/2-XBC	1.500	.875	.8750	1 1/2	3/4	7/8-14	5/16	3/8	3/32	3/16	15/16	.8750	2000	5330	11300	20
HR-1 5/8-BC	HR-1 5/8-XBC	1.625															
HR-1 3/4-BC	HR-1 3/4-XBC	1.750	1.000	1.0000	1 3/4	7/8	1-14	5/16	7/16	3/32	3/16	1 3/32	1.0000	2500	7600	15870	20
HR-1 7/8-BC	HR-1 7/8-XBC	1.875															
HR-2-BC	HR-2-XBC	2.000	1.250	1.1250	2	1	1 1/8-12	7/16	1/2	5/32	3/16	1 7/32	1.1250	3000	10050	22000	24
HR-2 1/4-BC	HR-2 1/4-XBC	2.250															
HR-2 1/2-BC	HR-2 1/2-XBC	2.500	1.500	1.2500	2 1/4	1 1/8	1 1/4-12	1/2	9/16	5/32	3/16	1 5/16	1.2500	4000	15280	33000	30
HR-2 3/4-BC	HR-2 3/4-XBC	2.750															
HR-3-BC	HR-3-XBC	3.000	1.750	1.5000	2 1/2	1 1/4	1 1/2-12	5/8	5/8	5/32	1/4	1 3/4	1.5000	5000	20200	49900	30
HR-3 1/4-BC	HR-3 1/4-XBC	3.250															
HR-3 1/2-BC	HR-3 1/2-XBC	3.500	2.000	1.7500	2 3/4	1 3/8	1 3/4-12	5/8	11/16	5/32	1/4	1 15/16	1.7500	6000	29660	63000	30
HR-4-BC	HR-4-XBC	4.000	2.250	2.0000	3 1/2	1 1/2	2-12	3/4	3/4	5/32	1/4	2 1/4	2.0000	8000	35980	90000	30

▲ Relubricate through threaded end only.  
▲▲ Cannot be relubricated.

## YR-C & YR-XC

### Crowned • Yoke Type

Crowned Outer Race  
for Shaft Mounting  
Sealed or Unsealed  
X = Sealed

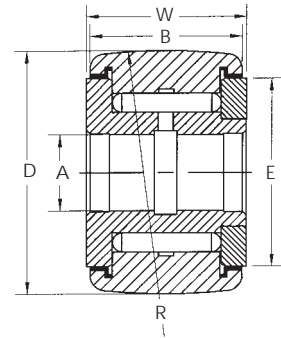

Dimensional Data (inches)

SMITH Bearing® Number		D Roller O.D. +.000 -.001	A Bore Nominal	Tolerance	B Roller Width +.000 -.005	W Overall Width +.005 -.010	E Min Clamping Dia.	Recommended Shaft Dia.				Basic Dynamic Rating (lbs)	Max Static Capacity (lbs)	R Crown Radius (Inches)
UNSEALED	SEALED							Slip Fit		Press Fit				
								Max.	Min.	Max.	Min.			
YR-3/4-C	YR-3/4-XC	.750	.2500	+0.002 -0.004	.500	.5625	1/2	.2497	.2493	.2505	.2501	2140	4170	10
YR-7/8-C	YR-7/8-XC	.875												
YR-1-C	YR-1-XC	1.000	.3125		.625	.6875	5/8	.3122	.3118	.3130	.3126	3030	6200	12
YR-1 1/8-C	YR-1 1/8-XC	1.125												
YR-1 1/4-C	YR-1 1/4-XC	1.250	.3750		.750	.8125	3/4	.3747	.3743	.3755	.3751	44700	8600	14
YR-1 3/8-C	YR-1 3/8-XC	1.375												
YR-1 1/2-C	YR-1 1/2-XC	1.500	.4375		.875	.9375	57/64	.4372	.4368	.4380	.4376	5560	11300	20
YR-1 5/8-C	YR-1 5/8-XC	1.625												
YR-1 3/4-C	YR-1 3/4-XC	1.750	.5000		1.000	1.0625	1 3/64	.4997	.4993	.5007	.5003	7870	15870	20
YR-1 7/8-C	YR-1 7/8-XC	1.875												
YR-2-C	YR-2-XC	2.000	.6250		1.250	1.3125	1 13/64	.6247	.6243	.6257	.6253	10370	22000	24
YR-2 1/4-C	YR-2 1/4-XC	2.250												
YR-2 1/2-C	YR-2 1/2-XC	2.500	.7500	1.500	1.5625	1 5/16	.7497	.7493	.7507	.7503	15280	33000	30	
YR-2 3/4-C	YR-2 3/4-XC	2.750												
YR-3-C	YR-3-XC	3.000	1.0000	1.750	1.8125	1 3/4	.9996	.9992	1.0008	1.0003	202000	49900	30	
YR-3 1/4-C	YR-3 1/4-XC	3.250												
YR-3 1/2-C	YR-3 1/2-XC	3.500	1.1250	2.000	2.0625	2	1.1246	1.1241	1.1258	1.1253	29660	63300	30	
YR-4-C	YR-4-XC	4.000												
	YR-5-XC	5.000	1.2500	2.250	2.3125	2 1/4	1.2496	1.2491	1.2508	1.2503	35980	90000	30	
	YR-6-XC	6.000												
	YR-5-XC	5.000	1.7500	2.750	2.8750	3	1.7496	1.7491	1.7508	1.7503	49750	136000	48	
	YR-6-XC	6.000	2.2500	3.250	3.3750	3 1/2	2.2496	2.2491	2.2508	2.2503	71400	162000	56	



**DCR Series**  
Stud Type

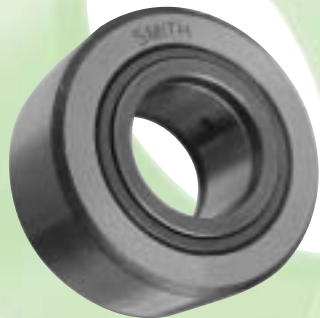

**DYR Series**  
Yoke Type

# Heavy Duty Rollers

## Double Row

INCH SIZES  
YOKE & STUD TYPE

The SMITH® DCR & DYR Series  
are Cam Followers with a  
Double set of Heavy Rollers  
and Thicker Outer Rings  
for increased load handling  
and extended life.

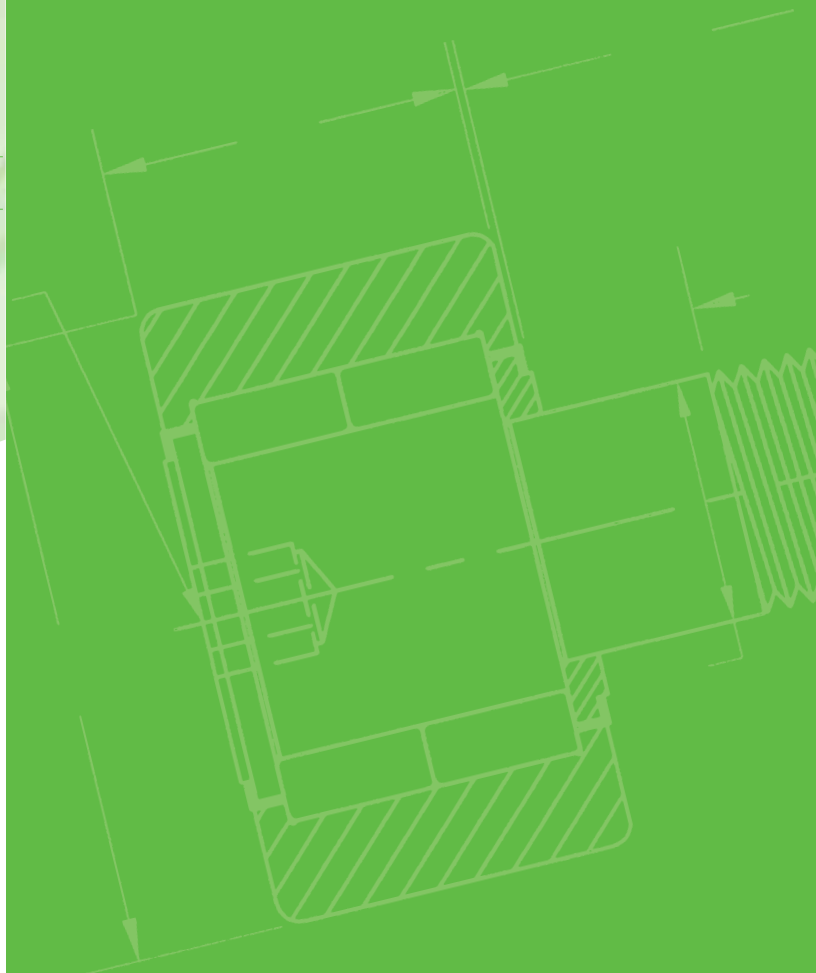



**DCR**

**Double Row • Heavy Roller**

**Stud Type**

**Shielded • Full Complement**

Hex-Drive Socket

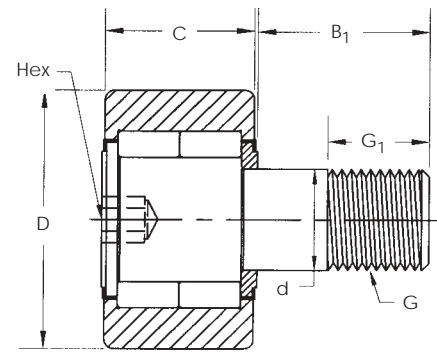

**INTERCHANGE**

SMITH®	RBC
DCR-1 <sup>1</sup> / <sub>2</sub>	RBC-1 <sup>1</sup> / <sub>2</sub>
DCR-1 <sup>5</sup> / <sub>8</sub>	RBC-1 <sup>5</sup> / <sub>8</sub>
DCR-1 <sup>3</sup> / <sub>4</sub>	RBC-1 <sup>3</sup> / <sub>4</sub>
DCR-1 <sup>7</sup> / <sub>8</sub>	RBC-1 <sup>7</sup> / <sub>8</sub>
DCR-2	RBC-2
DCR-2 <sup>1</sup> / <sub>4</sub>	RBC-2 <sup>1</sup> / <sub>4</sub>
DCR-2 <sup>1</sup> / <sub>2</sub>	RBC-2 <sup>1</sup> / <sub>2</sub>
DCR-2 <sup>3</sup> / <sub>4</sub>	RBC-2 <sup>3</sup> / <sub>4</sub>
DCR-3	RBC-3
DCR-3 <sup>1</sup> / <sub>4</sub>	RBC-3 <sup>1</sup> / <sub>4</sub>
DCR-3 <sup>1</sup> / <sub>2</sub>	RBC-3 <sup>1</sup> / <sub>2</sub>
DCR-4	RBC-4
DCR-5	RBC-5
DCR-6	RBC-6

**General Information**

The **SMITH DCR** series is designed to meet higher performance requirements. Bearings are provided with a double row of **Heavy Duty Rollers**, thicker outer ring and contact seals all which provide a longer life. Consult our Engineering Department for special variations.

Bearings are dimensionally interchangeable, however internal design varies between manufacturers.

Dimensional Data (inches)

SMITH Bearing® Number	D Roller O.D. + .000 - .001	C Roller Width + .000 - .005	d Stud Dia. + .001 - .000	B1 Stud Length	G1 Eff. Thread Min.	G Thread U.N.F. Class 2A	HEX Size	Bearing Dynamic Capacity (lbs)	Bearing Static Capacity (lbs)	Max. Allow Load (lbs)	Track Capacity at 40RC (lbs)	Max. Clamp Torque (lbs-ft)
DCR-1 <sup>1</sup> / <sub>2</sub>	1.500	.875	.625	1.500	.750	5/8-18	3/8	5,660	6,180	2,470	3,260	32
DCR-1 <sup>5</sup> / <sub>8</sub>	1.625	.875	.625	1.500	.750	5/8-18	3/8	5,660	6,180	2,890	3,530	32
DCR-1 <sup>3</sup> / <sub>4</sub>	1.750	1.000	.750	1.750	.875	3/4-16	3/8	8,400	10,800	3,200	4,460	62
DCR-1 <sup>7</sup> / <sub>8</sub>	1.875	1.000	.750	1.750	.875	3/4-16	3/8	8,400	10,800	3,910	4,750	62
DCR-2	2.000	1.250	.875	2.000	1.000	7/8-14	1/2	12,800	17,700	5,400	6,400	75
DCR-2 <sup>1</sup> / <sub>4</sub>	2.250	1.250	.875	2.000	1.000	7/8-14	1/2	12,800	17,700	6,800	7,200	75
DCR-2 <sup>1</sup> / <sub>2</sub>	2.500	1.500	1.000	2.250	1.125	1-14	9/16	17,300	20,800	9,000	9,200	108
DCR-2 <sup>3</sup> / <sub>4</sub>	2.750	1.500	1.000	2.250	1.125	1-14	9/16	17,300	20,800	10,800	10,200	108
DCR-3	3.000	1.750	1.250	2.500	1.250	1 <sup>1</sup> / <sub>4</sub> -12	5/8	29,700	40,200	14,700	13,100	166
DCR-3 <sup>1</sup> / <sub>4</sub>	3.250	1.750	1.250	2.500	1.250	1 <sup>1</sup> / <sub>4</sub> -12	5/8	29,700	40,200	17,500	14,100	166
DCR-3 <sup>1</sup> / <sub>2</sub>	3.500	2.000	1.375	2.750	1.375	1 <sup>3</sup> / <sub>8</sub> -12	5/8	37,000	49,500	21,000	17,000	208
DCR-4	4.000	2.250	1.500	3.500	1.500	1 <sup>1</sup> / <sub>2</sub> -12	3/4	46,700	58,800	23,400	21,600	250
DCR-5	5.000	2.750	2.000	5.062	1.563	2-12	1	72,400	98,400	43,300	34,420	250
DCR-6	6.000	3.250	2.500	6.000	3.000	2 <sup>1</sup> / <sub>2</sub> -12	1	93,800	160,000	59,500	50,500	250

- 1) Add suffix "C" for Crowned Outer Race. Example: **DCR-2-C**.
- 2) Lubrication Holes available upon request.
- 3) Available Unsealed upon request.

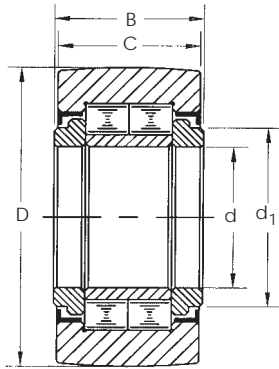

**DYR**  
**Double Row • Heavy Roller**  
**Yoke Type**  
**Shielded • Full Complement**

**INTERCHANGE**

SMITH®	RBC
DYR-1 1/2	RBY-1 1/2
DYR-1 5/8	RBY-1 5/8
DYR-1 3/4	RBY-1 3/4
DYR-1 7/8	RBY-1 7/8
DYR-2	RBY-2
DYR-2 1/4	RBY-2 1/4
DYR-2 1/2	RBY-2 1/2
DYR-2 3/4	RBY-2 3/4
DYR-3	RBY-3
DYR-3 1/4	RBY-3 1/4
DYR-3 1/2	RBY-3 1/2
DYR-4	RBY-4
DYR-5	RBY-5
DYR-6	RBY-6

**General Information**

The **SMITH DYR** series is designed to meet higher performance requirements. Bearings are provided with a double row of **Heavy Duty Rollers**, thicker outer ring and contact seals all which provide a longer life. Consult our Engineering Department for special variations.

Bearings are dimensionally interchangeable, however internal design varies between manufacturers.

**Dimensional Data (inches)**

SMITH Bearing® Number	D Roller O.D. + .000 - .001	d Bore Diameter	Tolerance	C Roller Width + .000 - .005	B Overall Width + .005 - .010	d1 Shoulder Diameter	Bearing Dynamic Capacity (lbs)	Bearing Static Capacity (lbs)	Max Allow. Load (lbs)	Track Capacity at 40 RC (lbs)
SEALED										
DYR-1 1/2	1.500	.4375	+ .0002 - .0004	.875	.9375	.750	5,660	6,180	3,200	3,260
DYR-1 5/8	1.625	.4375		.875	.9375	.750	5,660	6,180	3,420	3,530
DYR-1 3/4	1.750	.500		1.000	1.0625	1.000	8,400	10,800	4,100	4,460
DYR-1 7/8	1.875	.500		1.000	1.0625	1.000	8,400	10,800	5,480	4,750
DYR-2	2.000	.625		1.250	1.3125	1.125	12,800	17,700	7,050	6,400
DYR-2 1/4	2.250	.625		1.250	1.3125	1.125	12,800	17,700	10,980	7,200
DYR-2 1/2	2.500	.750		1.500	1.5625	1.250	17,300	20,800	13,300	9,200
DYR-2 3/4	2.750	.750		1.500	1.5625	1.250	17,300	20,800	17,200	10,200
DYR-3	3.000	1.000	+ .0001 - .0005	1.750	1.8125	1.500	29,700	40,200	18,800	13,100
DYR-3 1/4	3.250	1.000		1.750	1.8125	1.500	29,700	40,200	26,200	14,100
DYR-3 1/2	3.500	1.125		2.000	2.0625	1.625	37,000	49,500	28,700	17,000
DYR-4	4.000	1.250		2.250	2.3125	1.750	46,700	58,800	30,500	21,600
DYR-5	5.000	1.750		2.750	2.8750	2.250	72,400	98,400	56,600	34,420
DYR-6	6.000	2.250		3.250	3.3750	3.000	93,800	160,000	76,000	50,500

- 1) Add suffix "C" for Crowned Outer Race. Example: **DYR-2-C**.
- 2) Lubrication Holes available upon request.
- 3) Available Unsealed upon request.

INTERCHANGE TABLES

Unsealed Cam Followers

Regular Stud • Unsealed

SMITH®	McGill	RBC	Torrington
CR - 1/2-A	CF - 1/2-N	—	CR - 8
CR - 1/2	CF - 1/2	S - 16	CR - 8-1
CR - 9/16	CF - 9/16	S - 18	—
CR - 5/8-A	CF - 5/8-N	—	CR - 10
CR - 5/8	CF - 5/8	S - 20	CR - 10-1
CR - 11/16	CF - 11/16	S - 22	—
CR - 3/4	CF - 3/4	S - 24	CR - 12
CR - 7/8	CF - 7/8	S - 28	CR - 14
CR - 1	CF - 1	S - 32	CR - 16
CR - 1 1/8	CF - 1 1/8	S - 36	CR - 18
CR - 1 1/4	CF - 1 1/4	S - 40	CR - 20
CR - 1 3/8	CF - 1 3/8	S - 44	CR - 22
CR - 1 1/2	CF - 1 1/2	S - 48	CR - 24
CR - 1 5/8	CF - 1 5/8	S - 52	CR - 26
CR - 1 3/4	CF - 1 3/4	S - 56	CR - 28
CR - 1 7/8	CF - 1 7/8	S - 60	CR - 30
CR - 2	CF - 2	S - 64	CR - 32
CR - 2 1/4	CF - 2 1/4	S - 72	CR - 36
CR - 2 1/2	CF - 2 1/2	S - 80	CR - 40
CR - 2 3/4	CF - 2 3/4	S - 88	CR - 44
CR - 3	CF - 3	S - 96	CR - 48
CR - 3 1/4	CF - 3 1/4	S - 104	CR - 52
CR - 3 1/2	CF - 3 1/2	S - 112	CR - 56
CR - 4	CF - 4	S - 128	CR - 64
CR - 5	CF - 5	S - 160	CR - 80
CR - 6	CF - 6	S - 192	CR - 96

Heavy Stud • Unsealed

SMITH®	McGill	RBC
HR - 1/2	CFH - 1/2	H-16
HR - 5/8	CFH - 5/8	H-20
HR - 3/4	CFH - 3/4	H-24
HR - 7/8	CFH - 7/8	H-28
HR - 1	CFH - 1	H-32
HR - 1 1/8	CFH - 1 1/8	H-36
HR - 1 1/4	CFH - 1 1/4	H-40
HR - 1 3/8	CFH - 1 3/8	H-44
HR - 1 1/2	CFH - 1 1/2	H-48
HR - 1 5/8	CFH - 1 5/8	H-52
HR - 1 3/4	CFH - 1 3/4	H-56
HR - 1 7/8	CFH - 1 7/8	H-60
HR - 2	CFH - 2	H-64
HR - 2 1/4	CFH - 2 1/4	H-72
HR - 2 1/2	CFH - 2 1/2	H-80
HR - 2 3/4	CFH - 2 3/4	H-88
HR - 3	CFH - 3	H-96
HR - 3 1/4	CFH - 3 1/4	H-104
HR - 3 1/2	CFH - 3 1/2	H-112
HR - 4	CFH - 4	H-128

Yoke Roller • Unsealed

SMITH®	McGill	RBC	Torrington
YR - 3/4	CYR - 3/4	Y-24	YCR - 12
YR - 7/8	CYR - 7/8	Y-28	YCR - 14
YR - 1	CYR - 1	Y-32	YCR - 16
YR - 1 1/8	CYR - 1 1/8	Y-36	YCR - 18
YR - 1 1/4	CYR - 1 1/4	Y-40	YCR - 20
YR - 1 3/8	CYR - 1 3/8	Y-44	YCR - 22
YR - 1 1/2	CYR - 1 1/2	Y-48	YCR - 24
YR - 1 5/8	CYR - 1 5/8	Y-52	YCR - 26
YR - 1 3/4	CYR - 1 3/4	Y-56	YCR - 28
YR - 1 7/8	CYR - 1 7/8	Y-60	YCR - 30
YR - 2	CYR - 2	Y-64	YCR - 32
YR - 2 1/4	CYR - 2 1/4	Y-72	YCR - 36
YR - 2 1/2	CYR - 2 1/2	Y-80	YCR - 40
YR - 2 3/4	CYR - 2 3/4	Y-88	YCR - 44
YR - 3	CYR - 3	Y-96	YCR - 48
YR - 3 1/4	CYR - 3 1/4	Y-104	YCR - 52
YR - 3 1/2	CYR - 3 1/2	Y-112	YCR - 56
YR - 4	CYR - 4	Y-128	YCR - 64
YR - 5	CYR - 5	Y-160	YCR - 80
YR - 6	CYR - 6	Y-192	YCR - 96

Optional Features	SMITH®	McGill	RBC	Torrington
Hex-Drive	Add Suffix "B"	Add Suffix "B"	Add Suffix "W"	Add Prefix "B"
Eccentric	Add Suffix "E"	Add Suffix "E"	Add Suffix "X"	Add Prefix "E"
Crowned O.D.	Add Suffix "C"	Add Prefix "C"	Add Prefix "C"	Add Prefix "C"
Thrust Seal	Add Suffix "L"	—	Replace "S" with "L"	—

INTERCHANGE TABLES

Sealed Cam Followers

Regular Stud • Sealed

SMITH®	McGill	RBC	Torrington
CR - 1/2-AX	CF - 1/2-N-S	---	CRS - 8
CR - 1/2-X	CF - 1/2-S	S - 16 -S	CRS - 8-1
CR - 9/16-X	CF - 9/16-S	S - 18 -S	---
CR - 5/8-AX	CF - 5/8-N-S	---	CRS - 10
CR - 5/8-X	CF - 5/8-S	S - 20 -S	CRS - 10-1
CR - 11/16-X	CF - 11/16-S	S - 22 -S	---
CR - 3/4-X	CF - 3/4-S	S - 24 -S	CRS - 12
CR - 7/8-X	CF - 7/8-S	S - 28 -S	CRS - 14
CR - 1-X	CF - 1 -S	S - 32 -S	CRS - 16
CR - 1 1/8-X	CF - 1 1/8-S	S - 36 -S	CRS - 18
CR - 1 1/4-X	CF - 1 1/4-S	S - 40 -S	CRS - 20
CR - 1 3/8-X	CF - 1 3/8-S	S - 44 -S	CRS - 22
CR - 1 1/2-X	CF - 1 1/2-S	S - 48 -S	CRS - 24
CR - 1 5/8-X	CF - 1 5/8-S	S - 52 -S	CRS - 26
CR - 1 3/4-X	CF - 1 3/4-S	S - 56 -S	CRS - 28
CR - 1 7/8-X	CF - 1 7/8-S	S - 60 -S	CRS - 30
CR - 2-X	CF - 2 -S	S - 64 -S	CRS - 32
CR - 2 1/4-X	CF - 2 1/4-S	S - 72 -S	CRS - 36
CR - 2 1/2-X	CF - 2 1/2-S	S - 80 -S	CRS - 40
CR - 2 3/4-X	CF - 2 3/4-S	S - 88 -S	CRS - 44
CR - 3-X	CF - 3 -S	S - 96 -S	CRS - 48
CR - 3 1/4-X	CF - 3 1/4-S	S - 104-S	CRS - 52
CR - 3 1/2-X	CF - 3 1/2-S	S - 112-S	CRS - 56
CR - 4-X	CF - 4 -S	S - 128-S	CRS - 64
CR - 5-X	CF - 5 -S	S - 160-S	CRS - 80
CR - 6-X	CF - 6 -S	S - 192-S	CRS - 96

Heavy Stud • Sealed

SMITH®	McGill	RBC
HR - 1/2-X	CFH - 1/2-S	H-16 -S
HR - 5/8-X	CFH - 5/8-S	H-20 -S
HR - 3/4-X	CFH - 3/4-S	H-24 -S
HR - 7/8-X	CFH - 7/8-S	H-28 -S
HR - 1-X	CFH - 1 -S	H-32 -S
HR - 1 1/8-X	CFH - 1 1/8-S	H-36 -S
HR - 1 1/4-X	CFH - 1 1/4-S	H-40 -S
HR - 1 3/8-X	CFH - 1 3/8-S	H-44 -S
HR - 1 1/2-X	CFH - 1 1/2-S	H-48 -S
HR - 1 5/8-X	CFH - 1 5/8-S	H-52 -S
HR - 1 3/4-X	CFH - 1 3/4-S	H-56 -S
HR - 1 7/8-X	CFH - 1 7/8-S	H-60 -S
HR - 2-X	CFH - 2 -S	H-64 -S
HR - 2 1/4-X	CFH - 2 1/4-S	H-72 -S
HR - 2 1/2-X	CFH - 2 1/2-S	H-80 -S
HR - 2 3/4-X	CFH - 2 3/4-S	H-88 -S
HR - 3-X	CFH - 3 -S	H-96 -S
HR - 3 1/4-X	CFH - 3 1/4-S	H-104 -S
HR - 3 1/2-X	CFH - 3 1/2-S	H-112 -S
HR - 4-X	CFH - 4 -S	H-128 -S

Yoke Roller • Sealed

SMITH®	McGill	RBC	Torrington
YR - 3/4-X	CYR - 3/4-S	Y-24 -S	YCRS - 12
YR - 7/8-X	CYR - 7/8-S	Y-28 -S	YCRS - 14
YR - 1-X	CYR - 1 -S	Y-32 -S	YCRS - 16
YR - 1 1/8-X	CYR - 1 1/8-S	Y-36 -S	YCRS - 18
YR - 1 1/4-X	CYR - 1 1/4-S	Y-40 -S	YCRS - 20
YR - 1 3/8-X	CYR - 1 3/8-S	Y-44 -S	YCRS - 22
YR - 1 1/2-X	CYR - 1 1/2-S	Y-48 -S	YCRS - 24
YR - 1 5/8-X	CYR - 1 5/8-S	Y-52 -S	YCRS - 26
YR - 1 3/4-X	CYR - 1 3/4-S	Y-56 -S	YCRS - 28
YR - 1 7/8-X	CYR - 1 7/8-S	Y-60 -S	YCRS - 30
YR - 2-X	CYR - 2 -S	Y-64 -S	YCRS - 32
YR - 2 1/4-X	CYR - 2 1/4-S	Y-72 -S	YCRS - 36
YR - 2 1/2-X	CYR - 2 1/2-S	Y-80 -S	YCRS - 40
YR - 2 3/4-X	CYR - 2 3/4-S	Y-88 -S	YCRS - 44
YR - 3-X	CYR - 3 -S	Y-96 -S	YCRS - 48
YR - 3 1/4-X	CYR - 3 1/4-S	Y-104-S	YCRS - 52
YR - 3 1/2-X	CYR - 3 1/2-S	Y-112-S	YCRS - 56
YR - 4-X	CYR - 4 -S	Y-128-S	YCRS - 64
YR - 5-X	CYR - 5 -S	Y-160-S	YCRS - 80
YR - 6-X	CYR - 6 -S	Y-192-S	YCRS - 96

Optional Features	SMITH®	McGill	RBC	Torrington
Hex-Drive	Add Suffix "B"	Add Suffix "B"	Add Suffix "W"	Add Prefix "B"
Eccentric	Add Suffix "E"	Add Suffix "E"	Add Suffix "X"	Add Prefix "E"
Crowned O.D.	Add Suffix "C"	Add Prefix "C"	Add Prefix "C"	Add Prefix "C"
Thrust Seal	Add Suffix "L"	-	Replace "S" with "L"	-

## CR-SS &amp; CR-X-SS

## Stainless Steel

## Stud Type

## Screwdriver Slot

Stainless Steel  
Stud Type with  
Screwdriver Slot  
Sealed or Unsealed  
X = Sealed



STAINLESS STEEL

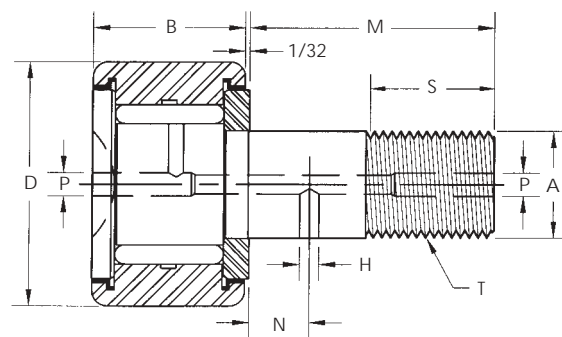

## General Information

The **SMITH CR-SS** and **YR-SS** Series of Cam Followers are manufactured from **440 Stainless Steel** for applications requiring increased corrosion resistance. Consult our Engineering Department for special configurations, sizes and materials to meet your needs.

## Dimensional Data (inches)

SMITH Bearing® Number		D Roller O.D. +.000 -.001	B Roller Width +.000 -.005	A Stud Dia. +.001 -.000	M Stud Length	S Eff. Thread Min.	T Thread U.N.F. Class 2A	N Oil Hole Location	H Oil Hole Dia.	P Lube Fitting Size	Min Boss Dia.	Recom. Bore +.0005 -.0005	Basic Dynamic Rating (lbs)
UNSEALED	SEALED												
CR-1/2-SS	CR-1/2-X-SS	.500	.375	.190	5/8	1/4	10-32	-	-	*1/8	19/64	.1900	475
CR-5/8-SS	CR-5/8-X-SS	.625	.4375	.250	3/4	5/16	1/4-28	-	-	*1/8	23/64	.2500	695
CR-3/4-SS	CR-3/4-X-SS	.750	.500	.375	7/8	3/8	3/8-24	1/4	3/32	3/16	1/2	.3750	1,245
CR-7/8-SS	CR-7/8-X-SS	.875	.500	.375	3/4	3/8	3/8-24	1/4	3/32	3/16	1/2	.3750	1,245
CR-1-SS	CR-1-X-SS	1.000	.625	.4375	1	1/2	7/16-20	1/4	3/32	3/16	5/8	.4375	1,560
CR-1 <sup>1</sup> / <sub>8</sub> -SS	CR-1 <sup>1</sup> / <sub>8</sub> -X-SS	1.125	.625	.4375	1	1/2	7/16-20	1/4	3/32	3/16	5/8	.4375	1,560
CR-1 <sup>1</sup> / <sub>4</sub> -SS	CR-1 <sup>1</sup> / <sub>4</sub> -X-SS	1.250	.750	.500	1 <sup>1</sup> / <sub>4</sub>	5/8	1/2-20	5/16	3/32	3/16	3/4	.5000	2,750
CR-1 <sup>3</sup> / <sub>8</sub> -SS	CR-1 <sup>3</sup> / <sub>8</sub> -X-SS	1.375	.750	.500	1 <sup>1</sup> / <sub>4</sub>	5/8	1/2-20	5/16	3/32	3/16	3/4	.5000	2,750
CR-1 <sup>1</sup> / <sub>2</sub> -SS	CR-1 <sup>1</sup> / <sub>2</sub> -X-SS	1.500	.875	.625	1 <sup>1</sup> / <sub>2</sub>	3/4	5/8-18	3/8	3/32	3/16	57/64	.6250	3,390
CR-1 <sup>5</sup> / <sub>8</sub> -SS	CR-1 <sup>5</sup> / <sub>8</sub> -X-SS	1.625	.875	.625	1 <sup>1</sup> / <sub>2</sub>	3/4	5/8-18	3/8	3/32	3/16	57/64	.6250	3,390
CR-1 <sup>3</sup> / <sub>4</sub> -SS	CR-1 <sup>3</sup> / <sub>4</sub> -X-SS	1.750	1.000	.750	1 <sup>3</sup> / <sub>4</sub>	7/8	3/4-16	7/16	3/32	3/16	1 <sup>3</sup> / <sub>64</sub>	.7500	4,470
CR-1 <sup>7</sup> / <sub>8</sub> -SS	CR-1 <sup>7</sup> / <sub>8</sub> -X-SS	1.875	1.000	.750	1 <sup>3</sup> / <sub>4</sub>	7/8	3/4-16	7/16	3/32	3/16	1 <sup>3</sup> / <sub>64</sub>	.7500	4,470
CR-2-SS	CR-2-X-SS	2.000	1.250	.875	2	1	7/8-14	1/2	5/32	3/16	1 <sup>13</sup> / <sub>64</sub>	.8750	5,660
CR-2 <sup>1</sup> / <sub>4</sub> -SS	CR-2 <sup>1</sup> / <sub>4</sub> -X-SS	2.250	1.250	.875	2	1	7/8-14	1/2	5/32	3/16	1 <sup>13</sup> / <sub>64</sub>	.8750	5,660
CR-2 <sup>1</sup> / <sub>2</sub> -SS	CR-2 <sup>1</sup> / <sub>2</sub> -X-SS	2.500	1.500	1.000	2 <sup>1</sup> / <sub>4</sub>	1 <sup>1</sup> / <sub>8</sub>	1-14	9/16	5/32	3/16	1 <sup>5</sup> / <sub>16</sub>	1.000	7,959
CR-2 <sup>3</sup> / <sub>4</sub> -SS	CR-2 <sup>3</sup> / <sub>4</sub> -X-SS	2.750	1.500	1.000	2 <sup>1</sup> / <sub>4</sub>	1 <sup>1</sup> / <sub>4</sub>	1-14	9/16	5/32	3/16	1 <sup>5</sup> / <sub>16</sub>	1.000	7,959
CR-3-SS	CR-3-X-SS	3.000	1.750	1.250	2 <sup>1</sup> / <sub>2</sub>	1 <sup>1</sup> / <sub>4</sub>	1 <sup>1</sup> / <sub>4</sub> -12	5/8	1/4	1/4	1 <sup>3</sup> / <sub>4</sub>	1.250	10,486

\* Relubricate through head end only.

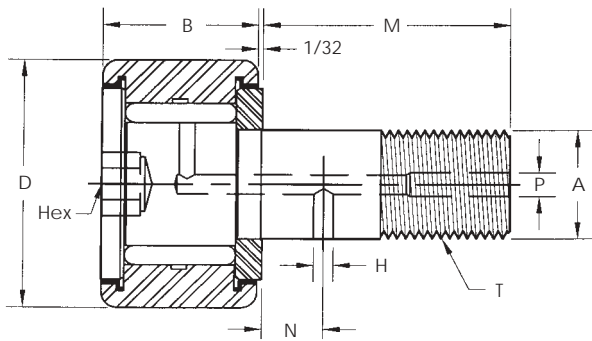

STAINLESS STEEL

CR-B-SS & CR-XB-SS

Stainless Steel

Stud Type

Hex-Drive Socket

Stainless Steel Stud Type with Hex-Drive Socket Sealed or Unsealed X = Sealed

General Information

The SMITH CR-SS and YR-SS Series of Cam Followers are manufactured from 440 Stainless Steel for applications requiring increased corrosion resistance. Consult our Engineering Department for special configurations, sizes and materials to meet your needs.

Dimensional Data (inches)

SMITH Bearing® Number		D Roller O.D.	B Roller Width	A Stud Dia.	M Stud Length	S Eff. Thread Min.	T Thread U.N.F. Class 2A	N Oil Hole Location	H Oil Hole Dia.	P Lube Fitting Size ▲	Hex Size	Min Boss. Dia.	Recom. Bore +.0005 -0.0000	Basic Dynamic Rating (lbs)
UNSEALED	SEALED	+0.000 -0.001	+0.000 -0.005	+0.001 -0.000										
CR-1/2-B-SS	CR-1/2-XB-SS	.500	.375	.190	5/8	1/4	10-32	-	-	▲▲	1/8	19/64	.190	475
CR-5/8-B-SS	CR-5/8-XB-SS	.625	.4375	.250	3/4	5/16	1/4-28	-	-	▲▲	1/8	23/64	.250	695
CR-3/4-B-SS	CR-3/4-XB-SS	.750	.500	.375	7/8	3/8	3/8-24	1/4	3/32	3/16	3/16	1/2	.375	1,245
CR-7/8-B-SS	CR-7/8-XB-SS	.875	.500	.375	3/4	3/8	3/8-24	1/4	3/32	3/16	3/16	1/2	.375	1,245
CR-1-B-SS	CR-1-XB-SS	1.000	.625	.4375	1	1/2	7/16-20	1/4	3/32	3/16	1/4	5/8	.4375	1,560
CR-1 1/8-B-SS	CR-1 1/8-XB-SS	1.125	.625	.4375	1	1/2	7/16-20	1/4	3/32	3/16	1/4	5/8	.4375	1,560
CR-1 1/4-B-SS	CR-1 1/4-XB-SS	1.250	.750	.500	1 1/4	5/8	1/2-20	5/16	3/32	3/16	1/4	3/4	.500	2,750
CR-1 3/8-B-SS	CR-1 3/8-XB-SS	1.375	.750	.500	1 1/4	5/8	1/2-20	5/16	3/32	3/16	1/4	3/4	.500	2,750
CR-1 1/2-B-SS	CR-1 1/2-XB-SS	1.500	.875	.625	1 1/2	3/4	5/8-18	3/8	3/32	3/16	5/16	57/64	.625	3,390
CR-1 5/8-B-SS	CR-1 5/8-XB-SS	1.625	.875	.625	1 1/2	3/4	5/8-18	3/8	3/32	3/16	5/16	57/64	.625	3,390
CR-1 3/4-B-SS	CR-1 3/4-XB-SS	1.750	1.000	.750	1 3/4	7/8	3/4-16	7/16	3/32	3/16	5/16	1 13/64	.750	4,470
CR-1 7/8-B-SS	CR-1 7/8-XB-SS	1.875	1.000	.750	1 3/4	7/8	3/4-16	7/16	3/32	3/16	5/16	1 13/64	.750	4,470
CR-2-B-SS	CR-2-XB-SS	2.000	1.250	.875	2	1	7/8-14	1/2	5/32	3/16	7/16	1 13/64	.875	5,660
CR-2 1/4-B-SS	CR-2 1/4-XB-SS	2.250	1.250	.875	2	1	7/8-14	1/2	5/32	3/16	7/16	1 13/64	.875	5,660
CR-2 1/2-B-SS	CR-2 1/2-XB-SS	2.500	1.500	1.000	2 1/4	1 1/8	1-14	9/16	5/32	3/16	1/2	1 5/16	1.000	7,959
CR-2 3/4-B-SS	CR-2 3/4-XB-SS	2.750	1.500	1.000	2 1/4	1 1/4	1-14	9/16	5/32	3/16	1/2	1 5/16	1.000	7,959
CR-3-B-SS	CR-3-XB-SS	3.000	1.750	1.250	2 1/2	1 1/4	1 1/4-12	5/8	1/4	1/4	5/8	1 3/4	1.250	10,486

▲ Relubricate through threaded end only.

▲▲ Cannot be relubricated.

**YR-SS & YR-X-SS****Stainless Steel****Yoke Type**

Stainless Steel  
Yoke Type  
for Shaft Mounting  
Sealed or Unsealed  
X = Sealed

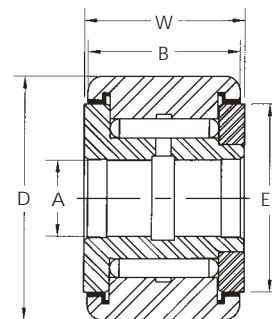
**STAINLESS STEEL****General Information**

The **SMITH CR-SS** and **YR-SS** Series of Cam Followers are manufactured from **440 Stainless Steel** for applications requiring increased corrosion resistance. Consult our Engineering Department for special configurations, sizes and materials to meet your needs.

## Dimensional Data (inches)

SMITH Bearing® Number		D Roller O.D. +.000 -.001	A Bore Nominal +.0002 -.0004	B Roller Width +.000 -.005	W Overall Width +.005 -.010	E Min Clamping Diameter	Recommended Shaft Dia. Transition Fits				Basic Dynamic Rating (lbs)
							Slip Fit		Press Fit		
							Max	Min	Max	Min	
YR-3/4-SS	YR-3/4-X-SS	.750	.250	.500	.5625	1/2	.2497	.2493	.2505	.2501	1,160
YR-7/8-SS	YR-7/8-X-SS	.875	.250	.500	.5625	1/2	.2497	.2493	.2505	.2501	1,160
YR-1-SS	YR-1-X-SS	1.000	.3125	.625	.6875	5/8	.3122	.3118	.3130	.3126	1,560
YR-1 <sup>1</sup> / <sub>8</sub> -SS	YR-1 <sup>1</sup> / <sub>8</sub> -X-SS	1.125	.3125	.625	.6875	5/8	.3122	.3118	.3130	.3126	1,560
YR-1 <sup>1</sup> / <sub>4</sub> -SS	YR-1 <sup>1</sup> / <sub>4</sub> -X-SS	1.250	.375	.750	.8125	3/4	.3747	.3743	.3755	.3751	2,750
YR-1 <sup>3</sup> / <sub>8</sub> -SS	YR-1 <sup>3</sup> / <sub>8</sub> -X-SS	1.375	.375	.750	.8125	3/4	.3747	.3743	.3755	.3751	2,750
YR-1 <sup>1</sup> / <sub>2</sub> -SS	YR-1 <sup>1</sup> / <sub>2</sub> -X-SS	1.500	.4375	.875	.9375	57/64	.4372	.4368	.4380	.4376	3,390
YR-1 <sup>5</sup> / <sub>8</sub> -SS	YR-1 <sup>5</sup> / <sub>8</sub> -X-SS	1.625	.4375	.875	.9300	57/64	.4372	.4368	.4380	.4376	3,390
YR-1 <sup>3</sup> / <sub>4</sub> -SS	YR-1 <sup>3</sup> / <sub>4</sub> -X-SS	1.750	.500	1.000	1.0625	1-3/64	.4997	.4993	.5007	.5003	4,470
YR-1 <sup>7</sup> / <sub>8</sub> -SS	YR-1 <sup>7</sup> / <sub>8</sub> -X-SS	1.875	.500	1.000	1.0625	1 <sup>3</sup> / <sub>64</sub>	.4997	.4993	.5007	.5003	4,470
YR-2-SS	YR-2-X-SS	2.000	.625	1.250	1.3125	1 <sup>13</sup> / <sub>64</sub>	.6247	.6243	.6257	.6253	5,660
YR-2 <sup>1</sup> / <sub>4</sub> -SS	YR-2 <sup>1</sup> / <sub>4</sub> -X-SS	2.250	.625	1.250	1.3125	1 <sup>13</sup> / <sub>64</sub>	.6247	.6243	.6257	.6253	5,660
YR-2 <sup>1</sup> / <sub>2</sub> -SS	YR-2 <sup>1</sup> / <sub>2</sub> -X-SS	2.500	.750	1.500	1.5625	1 <sup>5</sup> / <sub>16</sub>	.7497	.7493	.7507	.7503	7,959
YR-2 <sup>3</sup> / <sub>4</sub> -SS	YR-2 <sup>3</sup> / <sub>4</sub> -X-SS	2.750	.750	1.500	1.5625	1 <sup>5</sup> / <sub>16</sub>	.7497	.7493	.7507	.7503	7,959
YR-3-SS	YR-3-X-SS	3.000	1.000	1.750	1.8125	1 <sup>3</sup> / <sub>4</sub>	.9996	.9992	1.0008	1.0003	10,486

INTERCHANGE TABLES

Stainless Steel Cam Followers

Regular Stud Screw-Driver Slot

SMITH®	McGill	Carter
CR-1/2-SS	CF-1/2-CR	SC-16
CR-5/8-SS	CF-5/8-CR	SC-20
CR-3/4-SS	CF-3/4-CR	SC-24
CR-7/8-SS	CF-7/8-CR	SC-28
CR-1-SS	CF-1-CR	SC-32
CR-1 1/8-SS	CF-1 1/8-CR	SC-36
CR-1 1/4-SS	CF-1 1/4-CR	SC-40
CR-1 3/8-SS	CF-1 3/8-CR	SC-44
CR-1 1/2-SS	CF-1 1/2-CR	SC-48
CR-1 5/8-SS	CF-1 5/8-CR	SC-52
CR-1 3/4-SS	CF-1 3/4-CR	SC-56
CR-1 7/8-SS	CF-1 7/8-CR	SC-60
CR-2-SS	CF-2-CR	SC-64
CR-2 1/4-SS	CF-2 1/4-CR	SC-72
CR-2 1/2-SS	CF-2 1/2-CR	-
CR-2 3/4-SS	CF-2 3/4-CR	-
CR-3-SS	CF-3-CR	-
CR-4-SS	CF-4-CR	-

Regular Stud Hex Socket

SMITH®	McGill	Carter
CR-1/2-B-SS	CF-1/2-B-CR	SC-16-B
CR-5/8-B-SS	CF-5/8-B-CR	SC-20-B
CR-3/4-B-SS	CF-3/4-B-CR	SC-24-B
CR-7/8-B-SS	CF-7/8-B-CR	SC-28-B
CR-1-B-SS	CF-1-B-CR	SC-32-B
CR-1 1/8-B-SS	CF-1 1/8-B-CR	SC-36-B
CR-1 1/4-B-SS	CF-1 1/4-B-CR	SC-40-B
CR-1 3/8-B-SS	CF-1 3/8-B-CR	SC-44-B
CR-1 1/2-B-SS	CF-1 1/2-B-CR	SC-48-B
CR-1 5/8-B-SS	CF-1 5/8-B-CR	SC-52-B
CR-1 3/4-B-SS	CF-1 3/4-B-CR	SC-56-B
CR-1 7/8-SS	CF-1 7/8-B-CR	SC-60-B
CR-2-B-SS	CF-2-B-CR	SC-64-B
CR-2 1/4-B-SS	CF-2 1/4-B-CR	SC-72-B
CR-2 1/2-B-SS	CF-2 1/2-B-CR	-
CR-2 3/4-B-SS	CF-2 3/4-B-CR	-
CR-3-B-SS	CF-3-B-CR	-
CR-4-B-SS	CF-4-B-CR	-

Yoke Type

SMITH®	McGill	Carter
YR-3/4-SS	CYR-3/4-CR	SY-24
YR-7/8-SS	CYR-7/8-CR	SY-28
YR-1-SS	CYR-1-CR	SY-32
YR-1 1/8-SS	CYR-1 1/8-CR	SY-36
YR-1 1/4-SS	CYR-1 1/4-CR	SY-40
YR-1 3/8-SS	CYR-1 3/8-CR	SY-44
YR-1 1/2-SS	CYR-1 1/2-CR	SY-48
YR-1 5/8-SS	CYR-1 5/8-CR	SY-52
YR-1 3/4-SS	CYR-1 3/4-CR	SY-56
YR-1 7/8-SS	CYR-1 7/8-CR	SY-60
YR-2-SS	CYR-2-CR	SY-64
YR-2 1/4-SS	-	SY-72

Coding for Other Features

Optional Feature	SMITH®	McGILL	Carter
Sealed	add suffix "X"	add suffix "S"	add suffix "S"
Hex-Drive	add suffix "B"	add suffix "B"	add suffix "B"



**BCR & BCR-X****Non-Metallic Bushing****Stud Type**

## Screwdriver Slot

Stud Type with  
Non-Metallic Bushing  
Screwdriver Slot  
Sealed or Unsealed  
X = Sealed

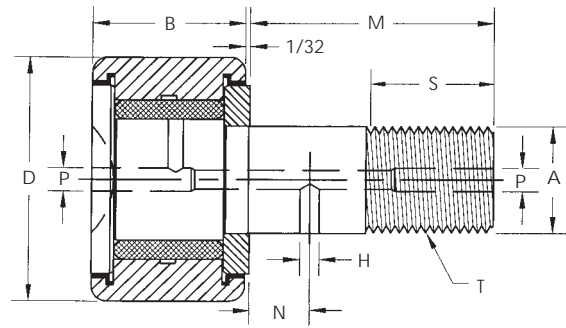

**NON-METALLIC  
BUSHING**

**General Information**

The **SMITH BCR** and **BYR** Series replace the standard steel needle rollers with a **non-metallic**, self-lubricating, engineered plastic bushing which eliminates or reduces the need for bearing lubrication. This product is available in **Sealed, Crowned & Eccentric Stud** type. The Load Capacity is based on speed used. Consult our Engineering Department for load calculations. Max allowable temperature 250°F typical. Higher temperature versions available.

## Dimensional Data (inches)

SMITH Bearing® Number		D Roller O.D. +.000 -.001	B Roller Width +.000 -.005	A Stud Dia. +.001 -.000	M Stud Length +.005 -.0005	S Eff. Thread Min.	T Thread U.N.F. Class 2A	N Oil Hole Location	H Oil Hole Dia.	P Lube Fitting Size	Min. Boss Dia.	Recom. Bore +.0005 -.0005
UNSEALED	SEALED											
BCR-1/2	BCR-1/2-X	.500	.375	.190	5/8	1/4	10-32	-	-	1/8	19/64	.190
BCR-5/8	BCR-5/8-X	.625	.4375	.250	3/4	5/16	1/4-28	-	-	1/8	23/64	.250
BCR-3/4	BCR-3/4-X	.750	.500	.375	7/8	3/8	3/8-24	1/4	3/32	3/16	1/2	.375
BCR-7/8	BCR-7/8-X	.875	.500	.375	3/4	3/8	3/8-24	1/4	3/32	3/16	1/2	.375
BCR-1	BCR-1-X	1.000	.625	.4375	1	1/2	7/16-20	1/4	3/32	3/16	5/8	.4375
BCR-1 <sup>1</sup> / <sub>8</sub>	BCR-1 <sup>1</sup> / <sub>8</sub> -X	1.125	.625	.4375	1	1/2	7/16-20	1/4	3/32	3/16	5/8	.4375
BCR-1 <sup>1</sup> / <sub>4</sub>	BCR-1 <sup>1</sup> / <sub>4</sub> -X	1.250	.750	.500	1 <sup>1</sup> / <sub>4</sub>	5/8	1/2-20	5/16	3/32	3/16	3/4	.500
BCR-1 <sup>3</sup> / <sub>8</sub>	BCR-1 <sup>3</sup> / <sub>8</sub> -X	1.375	.750	.500	1 <sup>1</sup> / <sub>4</sub>	5/8	1/2-20	5/16	3/32	3/16	3/4	.500
BCR-1 <sup>1</sup> / <sub>2</sub>	BCR-1 <sup>1</sup> / <sub>2</sub> -X	1.500	.875	.625	1 <sup>1</sup> / <sub>2</sub>	3/4	5/8-18	3/8	3/32	3/16	57/64	.625
BCR-1 <sup>5</sup> / <sub>8</sub>	BCR-1 <sup>5</sup> / <sub>8</sub> -X	1.625	.875	.625	1 <sup>1</sup> / <sub>2</sub>	3/4	5/8-18	3/8	3/32	3/16	57/64	.625
BCR-1 <sup>3</sup> / <sub>4</sub>	BCR-1 <sup>3</sup> / <sub>4</sub> -X	1.750	1.000	.750	1 <sup>3</sup> / <sub>4</sub>	7/8	3/4-16	7/16	3/32	3/16	1 <sup>3</sup> / <sub>64</sub>	.750
BCR-1 <sup>7</sup> / <sub>8</sub>	BCR-1 <sup>7</sup> / <sub>8</sub> -X	1.875	1.000	.750	1 <sup>3</sup> / <sub>4</sub>	7/8	3/4-16	7/16	3/32	3/16	1 <sup>3</sup> / <sub>64</sub>	.750
BCR-2	BCR-2-X	2.000	1.250	.875	2	1	7/8-14	1/2	5/32	3/16	1 <sup>13</sup> / <sub>64</sub>	.875
BCR-2 <sup>1</sup> / <sub>4</sub>	BCR-2 <sup>1</sup> / <sub>4</sub> -X	2.250	1.250	.875	2	1	7/8-14	1/2	5/32	3/16	1 <sup>13</sup> / <sub>64</sub>	.875
BCR-2 <sup>1</sup> / <sub>2</sub>	BCR-2 <sup>1</sup> / <sub>2</sub> -X	2.500	1.500	1.000	2 <sup>1</sup> / <sub>4</sub>	1 <sup>1</sup> / <sub>8</sub>	1-14	9/16	5/32	3/16	1 <sup>5</sup> / <sub>16</sub>	1.000
BCR-2 <sup>3</sup> / <sub>4</sub>	BCR-2 <sup>3</sup> / <sub>4</sub> -X	2.750	1.500	1.000	2 <sup>1</sup> / <sub>4</sub>	1 <sup>1</sup> / <sub>4</sub>	1-14	9/16	5/32	3/16	1 <sup>5</sup> / <sub>16</sub>	1.000
BCR-3	BCR-3-X	3.000	1.750	1.250	2 <sup>1</sup> / <sub>4</sub>	1 <sup>1</sup> / <sub>4</sub>	1 <sup>1</sup> / <sub>4</sub> -12	5/8	1/4	1/4	1 <sup>3</sup> / <sub>4</sub>	1.250

- 1) Add suffix "C" for Crowned. Example for Unsealed and Crowned: **BCR-1/2-C**. Example for Sealed and Crowned: **BCR-1/2-XC**.
- 2) Add suffix "E" for Eccentric. Example for Unsealed and Eccentric: **BCR-1/2-E**. Example for Sealed and Eccentric: **BCR-1/2-XE**.

NOTE: Bushing type bearings are designed for operation without lubrication at service temperature from -40° F to 200° F (250° F for short duration)

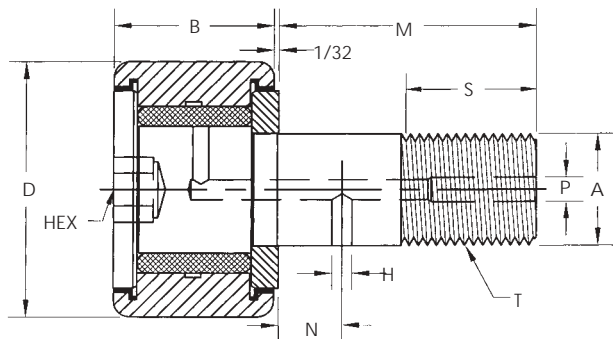

NON-METALLIC BUSHING

**BCR-B & BCR-XB**

**Non-Metallic Bushing**

**Stud Type**

**Hex-Drive Socket**

Stud Type with Non-Metallic Bushing  
Hex-Drive Socket  
Sealed or Unsealed  
X = Sealed

**General Information**

The **SMITH BCR** and **BYR** Series replace the standard steel needle rollers with a **non-metallic**, self-lubricating, engineered plastic bushing which eliminates or reduces the need for bearing lubrication. This product is available in **Sealed, Crowned & Eccentric Stud** type. The Load Capacity is based on speed used. Consult our Engineering Department for load calculations. Max allowable temperature 250°F typical. Higher temperature versions available.

Dimensional Data (inches)

SMITH Bearing® Number		D Roller O.D. +.000 -.001	B Roller Width +.000 -.005	A Stud Dia. +.001 -.000	M Stud Length +.005 -.0005	S Eff. Thread Min.	T Thread U.N.F. Class 2A	N Oil Hole Location	H Oil Hole Dia.	P Lube Fitting Size	Min. Boss Dia.	Recom. Bore +.0005 -.0005
UNSEALED	SEALED											
BCR-1/2-B	BCR-1/2-XB	.500	.375	.190	5/8	1/4	10-32	-	-	1/8	19/64	.190
BCR-5/8-B	BCR-5/8-XB	.625	.4375	.250	3/4	5/16	1/4-28	-	-	1/8	23/64	.250
BCR-3/4-B	BCR-3/4-XB	.750	.500	.375	7/8	3/8	3/8-24	1/4	3/32	3/16	1/2	.375
BCR-7/8-B	BCR-7/8-XB	.875	.500	.375	3/4	3/8	3/8-24	1/4	3/32	3/16	1/2	.375
BCR-1-B	BCR-1-XB	1.000	.625	.4375	1	1/2	7/16-20	1/4	3/32	3/16	5/8	.4375
BCR-1 1/8-B	BCR-1 1/8-XB	1.125	.625	.4375	1	1/2	7/16-20	1/4	3/32	3/16	5/8	.4375
BCR-1 1/4-B	BCR-1 1/4-XB	1.250	.750	.500	1 1/4	5/8	1/2-20	5/16	3/32	3/16	3/4	.500
BCR-1 3/8-B	BCR-1 3/8-XB	1.375	.750	.500	1 1/4	5/8	1/2-20	5/16	3/32	3/16	3/4	.500
BCR-1 1/2-B	BCR-1 1/2-XB	1.500	.875	.625	1 1/2	3/4	5/8-18	3/8	3/32	3/16	57/64	.625
BCR-1 5/8-B	BCR-1 5/8-XB	1.625	.875	.625	1 1/2	3/4	5/8-18	3/8	3/32	3/16	57/64	.625
BCR-1 3/4-B	BCR-1 3/4-XB	1.750	1.000	.750	1 3/4	7/8	3/4-16	7/16	3/32	3/16	1 3/64	.750
BCR-1 7/8-B	BCR-1 7/8-XB	1.875	1.000	.750	1 3/4	7/8	3/4-16	7/16	3/32	3/16	1 3/64	.750
BCR-2-B	BCR-2-XB	2.000	1.250	.875	2	1	7/8-14	1/2	5/32	3/16	1 13/64	.875
BCR-2 1/4-B	BCR-2 1/4-XB	2.250	1.250	.875	2	1	7/8-14	1/2	5/32	3/16	1 13/64	.875
BCR-2 1/2-B	BCR-2 1/2-XB	2.500	1.500	1.000	2 1/4	1 1/8	1-14	9/16	5/32	3/16	1 5/16	1.000
BCR-2 3/4-B	BCR-2 3/4-XB	2.750	1.500	1.000	2 1/4	1 1/4	1-14	9/16	5/32	3/16	1 5/16	1.000
BCR-3-B	BCR-3-XB	3.000	1.750	1.250	2 1/4	1 1/4	1 1/4-12	5/8	1/4	1/4	1 3/4	1.250

- 1) Add suffix "C" for Crowned. Example for Unsealed and Crowned: **BCR-1/2-BC**. Example for Sealed and Crowned: **BCR-1/2-XBC**.
- 2) Add suffix "E" for Eccentric. Example for Unsealed and Eccentric: **BCR-1/2-BE**. Example for Sealed and Eccentric: **BCR-1/2-XBE**.

NOTE: Bushing type bearings are designed for operation without lubrication at service temperature from -40° F to 200° F (250° F for short duration)

**BYR & BYR-X****Non-Metallic Bushing****Yoke Type**

Yoke Type with  
Non-Metallic Bushing  
for Shaft Mounting  
Sealed or Unsealed  
X = Sealed

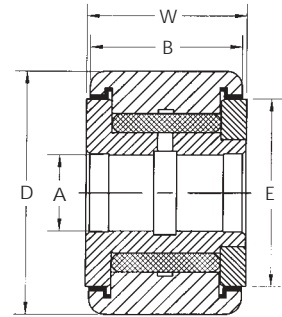

**NON-METALLIC  
BUSHING**

**General Information**

The **SMITH BCR** and **BYR** Series replace the standard steel needle rollers with a **non-metallic**, self-lubricating, engineered plastic bushing which eliminates or reduces the need for bearing lubrication. This product is available in **Sealed, Crowned & Eccentric Stud** type. The Load Capacity is based on speed used. Consult our Engineering Department for load calculations. Max allowable temperature 250°F typical. Higher temperature versions available.

## Dimensional Data (inches)

SMITH Bearing® Number		D Roller +.000 -.001	A Bore Nominal +.0002 -.0004	B Roller Width +.000 -.005	W Overall Width +.005 -.010	E Min Clamping Dia.	Recommended Shaft Diameter			
UNSEALED	SEALED						Slip Fit		Press Fit	
							Max	Min	Max	Max
BYR-3/4	BYR-3/4-X	.750	.250	.500	.5625	1/2	.2497	.2493	.2505	.2501
BYR-7/8	BYR-7/8-X	.875	.250	.500	.5625	1/2	.2497	.2493	.2505	.2501
BYR-1	BYR-1-X	1.000	.310	.625	.6875	5/8	.3122	.3118	.3130	.3126
BYR-1 <sup>1</sup> / <sub>8</sub>	BYR-1 <sup>1</sup> / <sub>8</sub> -X	1.125	.3125	.625	.6875	5/8	.3122	.3118	.3130	.3126
BYR-1 <sup>1</sup> / <sub>4</sub>	BYR-1 <sup>1</sup> / <sub>4</sub> -X	1.250	.375	.750	.8125	3/4	.3747	.3743	.3755	.3751
BYR-1 <sup>3</sup> / <sub>8</sub>	BYR-1 <sup>3</sup> / <sub>8</sub> -X	1.375	.375	.750	.8125	3/4	.3747	.3743	.3755	.3751
BYR-1 <sup>1</sup> / <sub>2</sub>	BYR-1 <sup>1</sup> / <sub>2</sub> -X	1.500	.4375	.875	.9375	57/64	.4372	.4368	.4380	.4376
BYR-1 <sup>5</sup> / <sub>8</sub>	BYR-1 <sup>5</sup> / <sub>8</sub> -X	1.625	.4375	.875	.9400	57/64	.4372	.4368	.4380	.4376
BYR-1 <sup>3</sup> / <sub>4</sub>	BYR-1 <sup>3</sup> / <sub>4</sub> -X	1.750	.500	1.000	1.0625	1 <sup>3</sup> / <sub>64</sub>	.4997	.4993	.5007	.5003
BYR-1 <sup>7</sup> / <sub>8</sub>	BYR-1 <sup>7</sup> / <sub>8</sub> -X	1.875	.500	1.000	1.0625	1 <sup>3</sup> / <sub>64</sub>	.4997	.4993	.5007	.5003
BYR-2	BYR-2-X	2.000	.625	1.250	1.3125	1 <sup>13</sup> / <sub>64</sub>	.6247	.6243	.6257	.6253
BYR-2 <sup>1</sup> / <sub>4</sub>	BYR-2 <sup>1</sup> / <sub>4</sub> -X	2.250	.625	1.250	1.3125	1 <sup>13</sup> / <sub>64</sub>	.6247	.6243	.6257	.6253
BYR-2 <sup>1</sup> / <sub>2</sub>	BYR-2 <sup>1</sup> / <sub>2</sub> -X	2.500	.750	1.500	1.5625	1 <sup>5</sup> / <sub>16</sub>	.7497	.7493	.7507	.7503
BYR-2 <sup>3</sup> / <sub>4</sub>	BYR-2 <sup>3</sup> / <sub>4</sub> -X	2.750	.750	1.500	1.5625	1 <sup>5</sup> / <sub>16</sub>	.7497	.7493	.7507	.7503
BYR-3	BYR-3-X	3.000	1.000	1.750	1.8125	1 <sup>3</sup> / <sub>4</sub>	.9996	.9992	1.0008	1.0003

1) Add suffix "C" for Crowned. Example for Unsealed and Crowned: **BYR-1/2-C**. Example for Sealed and Crowned: **BYR-1/2-XC**.

**NOTE:** Bushing type bearings are designed for operation without lubrication at service temperature from -40° F to 200° F (250° F for short duration)

Cam Followers with

**Non-Metallic Bushing**

**Stud Type Screw-Driver Slot**

SMITH®	McGill	Carter
BCR-1/2	BCF-1/2	N/A
BCR-5/8	BCF-5/8	N/A
BCR-11/16	BCF-11/16	N/A
BCR-3/4	BCF-3/4	N/A
BCR-7/8	BCF-7/8	N/A
BCR-1	BCF-1	N/A
BCR-11/8	BCF-11/8	N/A
BCR-11/4	BCF-11/4	N/A
BCR-13/8	BCF-13/8	N/A
BCR-11/2	BCF-11/2	N/A
BCR-15/8	BCF-15/8	N/A
BCR-13/4	BCF-13/4	N/A
BCR-17/8	BCF-17/8	N/A
BCR-2	BCF-2	N/A
BCR-21/4	BCF-21/4	N/A
BCR-21/2	BCF-21/2	N/A
BCR-23/4	BCF-23/4	N/A
BCR-3	BCF-3	N/A

**Stud Type Hex Socket**

SMITH®	McGill	Carter
BCR-1/2-B	BCF-1/2-B	SFH-16-A
BCR-5/8-B	BCF-5/8-B	SFH-20-A
BCR-11/16-B	BCF-11/16-B	SFH-22-A
BCR-3/4-B	BCF-3/4-B	SFH-24-A
BCR-7/8-B	BCF-7/8-B	SFH-28-A
BCR-1-B	BCF-1-B	SFH-32-A
BCR-11/8-B	BCF-11/8-B	SFH-36-A
BCR-11/4-B	BCF-11/4-B	SFH-40-A
BCR-13/8-B	BCF-13/8-B	SFH-44-A
BCR-11/2-B	BCF-11/2-B	SFH-48-A
BCR-15/8-B	BCF-15/8-B	SFH-52-A
BCR-13/4-B	BCF-13/4-B	SFH-56-A
BCR-17/8-B	BCF-17/8-B	SFH-60-A
BCR-2-B	BCF-2-B	SFH-64-A
BCR-21/4-B	BCF-21/4-B	SFH-72-A
BCR-21/2-B	BCF-21/2-B	SFH-80-A
BCR-23/4-B	BCF-23/4-B	SFH-88-A
BCR-3-B	BCF-3-B	SFH-96-A

**Yoke Type**

SMITH®	McGill	Carter
BYR-3/4	BCYR-3/4	NYR-24-A
BYR-7/8	BCYR-7/8	NYR-28-A
BYR-1	BCYR-1	NYR-32-A
BYR-11/8	BCYR-11/8	NYR-36-A
BYR-11/4	BCYR-11/4	NYR-40-A
BYR-13/8	BCYR-13/8	NYR-44-A
BYR-11/2	BCYR-11/2	NYR-48-A
BYR-15/8	BCYR-15/8	NYR-52-A
BYR-13/4	BCYR-13/4	NYR-56-A
BYR-17/8	BCYR-17/8	NYR-60-A
BYR-2	BCYR-2	NYR-64-A
BYR-21/4	BCYR-21/4	NYR-72-A
BYR-21/2	BCYR-21/2	NYR-80-A
BYR-23/4	BCYR-23/4	NYR-88-A
BYR-3	BCYR-3	NYR-96-A

**Coding for Other Features**

Optional Feature	SMITH®	McGILL
Sealed	add suffix "X"	add suffix "S"

**MCR & MCR-S**  
**MCRV & MCRV-S**  
 Single Row  
 Stud Type

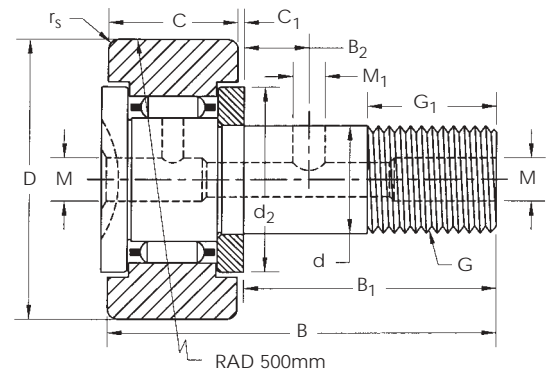

- MCR Caged Unsealed
- MCR-S Caged Sealed
- MCRV Full Complement Unsealed
- MCRV-S Full Complement Sealed

SMITH Bearing® Number	Dimensions (mm) <i>(For Tolerances, See chart in Engineering Section)</i>													Basic Load Ratings				Max Speed* (rpm)	Mass (grams)
	D	d	C**	r <sub>s</sub>	B	B <sub>1</sub>	B <sub>2</sub>	G	G <sub>1</sub>	M	M <sub>1</sub>	C <sub>1</sub>	d <sub>2</sub>	dyn Newtons	stat Newtons	dyn Newtons	stat Newtons		
	C	C <sub>0</sub>	C <sub>w</sub>	C <sub>ow</sub>	n	g													
MCR-16	16	6	11	0.15	28	16	-	M6 x 1	8	4†	-	0.6	12	3800	3750	3150	3300	22000	20
MCR-16-S																	16000		
MCRV-16														6400	8500	4850	6500	8500	22
MCRV-16-S																	8500		
MCR-19	19	8	11	0.15	32	20	-	M8 x 1.25	10	4†	-	0.6	14	4250	4600	3500	3900	20000	31.2
MCR-19-S																	14000		
MCRV-19														7300	10800	5500	7900	7000	35.2
MCRV-19-S																	7000		
MCR-22	22	10	12	0.30	36	23	-	M10 x 1	12	4	-	0.6	17	5700	6500	4450	5200	16000	48.3
MCR-22-S																	11000		
MCRV-22														8600	12900	6300	9100	6000	49.3
MCRV-22-S																	6000		
MCR-26	26	10	12	0.30	36	23	-	M10 x 1	12	4	-	0.6	17	5700	6500	5100	6200	16000	62.3
MCR-26-S																	11000		
MCRV-26														8600	12900	7300	11300	6000	65.3
MCRV-26-S																	6000		
MCR-30	30	12	14	0.60	40	25	6	M12 x 1.5	13	6	3	0.6	23	8100	9700	6800	8400	11000	92.5
MCR-30-S																	8300		
MCRV-30														12200	19000	9500	14600	4500	94.5
MCRV-30-S																	4500		
MCR-32	32	12	14	0.60	40	25	6	M12 x 1.5	13	6	3	0.6	23	8100	9700	7100	9000	11000	103.5
MCR-32-S																	8300		
MCRV-32														12200	19000	10000	15800	4500	105.5
MCRV-32-S																	4500		
MCR-35	35	16	18	0.60	52	32.5	8	M16 x 1.5	17	6	3	0.8	27	12900	19000	9700	14100	7000	181.5
MCR-35-S																	7000		
MCRV-35														18300	35000	12800	23000	3400	183.5
MCRV-35-S																	3400		
MCR-40	40	18	20	1.00	58	36.5	8	M18 x 1.5	19	6	3	0.8	32	14200	20400	10900	15500	6000	262.8
MCR-40-S																	6000		
MCRV-40														21000	39500	14800	26500	2900	264.8
MCRV-40-S																	2900		

† Relubricate through head end only.

\*\* Tolerance for "C" Raceway Width is +0.00/-0.12 mm

For Dimensional Tolerances, see Metric Tolerance Chart in Engineering Section.

**MCR & MCR-S**  
**MCRV & MCRV-S**

Single Row

Stud Type

(continued)

(chart continued from preceding page)

SMITH Bearing® Number	Dimensions (mm) <i>(For Tolerances, See chart in Engineering Section)</i>														Basic Load Ratings				Max Speed* (rpm)	Mass (grams)
	D	d	c**	r <sub>s</sub>	B	B <sub>1</sub>	B <sub>2</sub>	G	G <sub>1</sub>	M	M <sub>1</sub>	C <sub>1</sub>	d <sub>2</sub>	dyn Newtons	stat Newtons	dyn Newtons	stat Newtons			
	C	C <sub>0</sub>	C <sub>w</sub>	C <sub>ow</sub>	n	g														
MCR-47	47	20	24	1.0	66	40.5	9	M20x1.5	21	8	4	0.8	37	19500	32000	15500	25500	4900	405.5	
MCR-47-S																	4900			
MCRV-47														28000	59000	20600	42000	2600	409.5	
MCRV-47-S																	2600			
MCR-52	52	20	24	1.0	66	40.5	9	M20x1.5	21	8	4	0.8	37	19500	32000	16800	28500	4900	480.5	
MCR-52-S																	4900			
MCRV-52														28000	59000	22500	48000	2600	484.5	
MCRV-52-S																	2600			
MCR-62	62	24	29	1.0	80	49.5	11	M24x1.5	25	8	4	0.8	44	30500	53000	26500	47500	3800	818.2	
MCR-62-S																	3800			
MCRV-62														41500	91000	34000	76000	2200	830.2	
MCRV-62-S																	2200			
MCR-72	72	24	29	1.1	80	49.5	11	M24x1.5	25	8	4	0.8	44	30500	53000	28000	53000	3800	1068.2	
MCR-72-S																	3800			
MCRV-72														41500	91000	37000	85000	2200	1073.2	
MCRV-72-S																	2200			
MCR-80	80	30	35	1.1	100	63.0	15	M30x1.5	32	8	4	1.0	53	45000	85000	39500	77000	2600	1610.0	
MCR-80-S																	2600			
MCRV-80														60000	142000	49500	120000	1700	1621.0	
MCRV-80-S																	1700			
MCR-85	85	30	35	1.1	100	63.0	15	M30x1.5	32	8	4	1.0	53	45000	85000	40500	80000	2600	1800.0	
MCR-85-S																	2600			
MCRV-85														60000	142000	44000	120000	1700	1820.0	
MCRV-85-S																	1700			
MCR-90	90	30	35	1.1	100	63.0	15	M30x1.5	32	8	4	1.0	53	45000	85000	41500	83000	2600	2010.0	
MCR-90-S																	2600			
MCRV-90														60000	142000	53000	130000	1700	2030.0	
MCRV-90-S																	1700			

- 1) Standard bearing has Crowned Roller Outside Diameter – For Straight Cylindrical Outside Roller Diameter, add suffix “C.” Example: **MCR-16-C**
  - 2) Add suffix “B” for hex-drive socket. Example: **MCR-16-B**
  - 3) Add suffix “E” for eccentric collar. Example: **MCR-16-E**
  - 4) The basic load rating C and C<sub>0</sub> apply if the bearing outer ring (with cylindrical outside surface) is mounted in a housing bore with the normal rolling bearing fit. When used as a track roller, the load rating C<sub>w</sub> and C<sub>ow</sub> apply.
  - 5) \*Limiting Speed for grease lubrication: For oil lubrication speed may be increased by up to 30%.
  - 6) \*\* Tolerance for “C” Raceway Width is +0.00/-0.12 mm
- † Relubricate through head end only.

For Dimensional Tolerances, see Metric Tolerance Chart in Engineering Section.

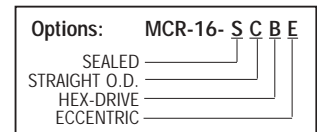

## MYR & MYR-S

## MYRV & MYRV-S

### Single Row

### Yoke Type

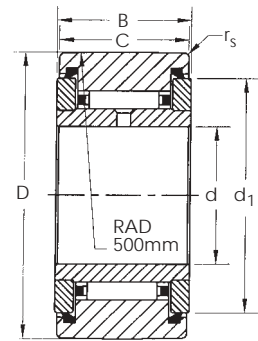

MYR Caged Unsealed  
 MYR-S Caged Sealed  
 MYRV Full Complement Unsealed  
 MYRV-S Full Complement Sealed

SMITH Bearing® Number  Add suffix "S" for Sealed	Dimensions (mm) <i>(For Tolerances, See chart in Engineering Section)</i>						Basic Load Ratings				Max Speed* (rpm)	Mass (grams)
							dyn Newtons		stat	Track Roller dyn Newtons		
	d	D	B	C**	r <sub>s</sub>	d <sub>1</sub>	C	C <sub>0</sub>	C <sub>w</sub>	C <sub>ow</sub>	n	g
MYR-5	5	16	12	11	0.15	12	3800	3750	3150	3300	22000	14
MYRV-5							6400	8500	4850	6500	8500	15
MYR-6	6	19	12	11	0.15	14	4250	4600	3500	3900	20000	20
MYRV-6							7300	10800	5500	7900	7000	21
MYR-8	8	24	15	14	0.30	19	6800	7700	5500	6400	15000	41
MYRV-8							10400	15600	7800	11400	5500	42
MYR-10	10	30	15	14	0.60	23	8100	9700	6800	8400	11000	64
MYRV-10							12200	19000	9500	14600	4500	65
MYR-12	12	32	15	14	0.60	25	8700	11000	6900	8800	9000	71
MYRV-12							13200	21700	9700	15400	3900	72
MYR-15	15	35	19	18	0.60	27	12900	19000	9700	14100	7000	103
MYRV-15							18300	35000	12800	23000	3400	105
MYR-17	17	40	21	20	1.00	32	14200	20400	10900	15500	6000	144
MYRV-17							21000	39500	14800	26500	2900	152
MYR-20	20	47	25	24	1.00	37	19500	32000	15500	25500	4900	246
MYRV-20							28000	59000	20600	42000	2600	254
MYR-25	25	52	25	24	1.00	42	21200	38000	15400	26500	3600	275
MYRV-25							31000	72000	20500	44000	2100	285
MYR-30	30	62	29	28	1.00	51	34000	59000	23600	38500	2600	470
MYRV-30							48500	108000	30500	63000	1700	481
MYR-35	35	72	29	28	1.10	58	37000	69000	25500	44500	2000	635
MYRV-35							53000	127000	33000	73000	1400	647
MYR-40	40	80	32	30	1.10	66	49000	94000	33000	59000	1700	805
MYRV-40							66000	159000	41000	90000	1300	890
MYR-45	45	85	32	30	1.10	72	51000	101000	32500	59000	1500	910
MYRV-45							61000	112000	41000	90000	1200	935
MYR-50	50	90	32	30	1.10	76	52000	108000	32000	59000	1300	960
MYRV-50							72000	191000	40500	93000	1000	990

- 1) Standard bearing has Crowned Roller Outside Diameter – For Straight Cylindrical Outside Roller Diameter, add suffix "C." Example: **MYR-5-C**
- 2) Add suffix "S" for sealed. Example for Sealed: **MYR-5-S**
- 3) The basic load rating C and C<sub>0</sub> apply if the bearing outer ring (with cylindrical outside surface) is mounted in a housing bore with the normal rolling bearing fit. When used as a track roller, the load rating C<sub>w</sub> and C<sub>ow</sub> apply.
- 4) \*Limiting Speed for grease lubrication: For oil lubrication speed may be increased by up to 30%. For Sealed bearings, speed in chart should be reduced by 30%.
- 5) \*\* Tolerance for "C" Raceway Width is +0.00/-0.12 mm

For Dimensional Tolerances, see Metric Tolerance Chart in Engineering Section.

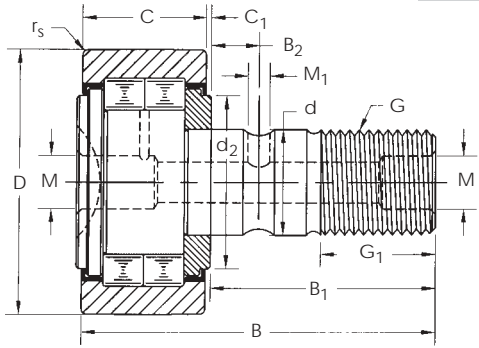

**NUKR**  
**Double Row • Heavy Rollers**  
**Stud Type**  
**Shielded • Full Complement**

NUKR bearings are standard with 500 mm Crowded Outer Race

SMITH Bearing® Number	Dimensions (mm) (For Tolerances, See chart in Engineering Section)													Basic Load Ratings				Max Speed* (rpm) n	Mass (grams) g
	D	d	C**	r <sub>s</sub>	B	B <sub>1</sub>	B <sub>2</sub>	G	G <sub>1</sub>	M	M <sub>1</sub>	C <sub>1</sub>	d <sub>2</sub>	dyn	stat	Track Roller			
														C	C <sub>0</sub>	C <sub>w</sub>	C <sub>ow</sub>		
NUKR-35	35	16	18	0.6	52	32.5	8	M16x1.5	17	6	3	0.8	21	23,000	27,000	16,000	18,300	6,500	176
NUKR-40	40	18	20	1	58	36.5	8	M18x1.5	19	6	3	0.8	23	24,800	31,000	18,500	22,800	5,500	257
NUKR-47	47	20	24	1	66	40.5	9	M20x1.5	21	8	4	0.8	27	39,000	50,000	28,000	34,500	4,200	380
NUKR-52	52	20	24	1	66	40.5	9	M20x1.5	21	8	4	0.8	31	43,500	60,000	29,000	37,500	3,400	450
NUKR-62	62	24	29	1	80	49.5	11	M24x1.5	25	8	4	0.8	38	59,000	79,000	40,500	51,000	2,600	795
NUKR-72	72	24	29	1.1	80	49.5	11	M24x1.5	25	8	4	0.8	44	65,000	93,000	45,000	61,000	2,100	1,200
NUKR-80	80	30	35	1.1	100	63	15	M30x1.5	32	8	4	1	47	95,000	133,000	67,000	93,000	1,800	1,800
NUKR-85	85	30	35	1.1	100	63	15	M30x1.5	32	8	4	1	47	96,000	133,000	67,000	93,000	1,800	1,740
NUKR-90	90	30	35	1.1	100	63	15	M30x1.5	32	8	4	1	47	95,000	133,000	77,000	110,000	1,800	2,300

- 1) The basic load rating C and C<sub>0</sub> apply if the bearing outer ring (with cylindrical outside surface) is mounted in a housing bore with the normal rolling bearing fit. When used as a track roller, the load rating C<sub>w</sub> and C<sub>ow</sub> apply.
- 2) \*Limiting Speed for grease lubrication: For oil lubrication speed may be increased by up to 30%.
- 3) \*\* Tolerance for "C" Raceway Width is +0.00/-0.12 mm
- 4) Add suffix "B" for hex-drive socket. Example for Hex-drive: **NUKR-35-B**
- 5) Add suffix "E" for eccentric sleeve. Example for Eccentric Sleeve: **NUKR-35-E**
- 6) Standard bearings have crowned outer race.  
For straight cylindrical outer race add suffix "C". Example for straight cylindrical outer race: **NUKR-35-C**

For Dimensional Tolerances, see Metric Tolerance Chart in Engineering Section.

**INTERCHANGE TABLE**

**Double Row • Heavy Rollers**  
**Shielded • Full Complement**

SMITH® • INA	McGILL
NUKR-35	MCFD-35
NUKR-40	MCFD-40
NUKR-47	MCFD-47
NUKR-52	MCFD-52
NUKR-62	MCFD-62
NUKR-72	MCFD-72
NUKR-80	MCFD-80
NUKR-85	MCFD-85
NUKR-90	MCFD-90



## MUTD

## Double Row • Heavy Rollers

## Yoke Type

## Shielded • Full Complement

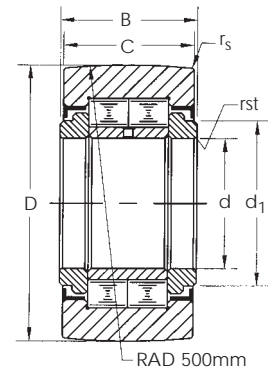

SMITH Bearing® Number	Dimensions (mm) (For Tolerances, See chart in Engineering Section)							Basic Load Ratings				Max Speed* (rpm)	Mass (grams)
								dyn Newtons		stat Newtons			
	d	D	B	C**	r <sub>s</sub>	rst	d <sub>1</sub>	C	C <sub>0</sub>	C <sub>w</sub>	C <sub>ow</sub>		
MUTD-15	15	35	19	18	0.6	0.3	20	23,000	27,000	16,000	18,300	6,500	99
MUTD-17	17	40	21	20	1	0.3	22	24,800	31,000	18,500	22,800	5,500	147
MUTD-1542	15	42	19	18	0.6	0.3	20	23,000	27,000	19,400	23,800	6,500	158
MUTD-1747	17	47	21	20	1	0.3	22	24,800	31,000	21,300	28,000	5,500	220
MUTD-20	20	47	25	24	1	0.3	27	39,000	50,000	28,000	35,000	4,200	245
MUTD-2052	20	52	25	24	1	0.3	27	39,000	50,000	31,500	41,000	4,200	321
MUTD-25	25	52	25	24	1	0.3	31	43,500	60,000	29,000	37,500	3,400	281
MUTD-2562	25	62	25	24	1	0.3	31	43,500	60,000	35,500	50,000	3,400	450
MUTD-30	30	62	29	28	1	0.3	38	59,000	79,000	40,000	51,000	2,600	465
MUTD-3072	30	72	29	28	1	0.3	38	59,000	79,000	48,000	65,000	2,600	697
MUTD-35	35	72	29	28	1.1	0.6	44	65,000	93,000	45,000	61,000	2,100	630
MUTD-3580	35	80	29	28	1.1	0.6	44	65,000	93,000	51,000	72,000	2,100	836
MUTD-40	40	80	32	30	1.1	0.6	51	90,000	134,000	56,000	76,000	1,600	816
MUTD-45	45	85	32	30	1.1	0.6	55	95,000	147,000	56,000	79,000	1,400	883
MUTD-4090	40	90	32	30	1.1	0.6	51	90,000	134,000	66,000	96,000	1,600	1,129
MUTD-50	50	90	32	30	1.1	0.6	60	100,000	161,000	57,000	81,000	1,300	950
MUTD-45100	45	100	32	30	1.1	0.6	55	95,000	147,000	72,000	108,000	1,400	1,396
MUTD-50110	50	110	32	30	1.1	0.6	60	100,000	161,000	76,000	121,000	1,300	1,690

- 1) The basic load rating C and C<sub>0</sub> apply if the bearing outer ring (with cylindrical outside surface) is mounted in a housing bore with the normal rolling bearing fit. When used as a track roller, the load rating C<sub>w</sub> and C<sub>ow</sub> apply.
- 2) Standard bearing has **Crowned Roller Outside Diameter** – For **Straight Cylindrical Outside Roller Diameter**, add suffix "C." Example: **MUTD-15-C**
- 3) \*Limiting Speed is given for a lightly loaded bearing with oil lubrication.
- 4) \*\* Tolerance for "C" Raceway Width is +0.00/-0.12 mm

## INTERCHANGE TABLE

Double Row • Heavy Rollers  
Shielded • Full Complement

SMITH®	McGILL	INA
MUTD-15	MCYRD-15	NUTR-15
MUTD-17	MCYRD-17	NUTR-17
MUTD-1542	MCYRD-1542	NUTR-1542
MUTD-1747	MCYRD-1747	NUTR-1747
MUTD-20	MCYRD-20	NUTR-20
MUTD-2052	MCYRD-2052	NUTR-2052
MUTD-25	MCYRD-25	NUTR-25
MUTD-2562	MCYRD-2562	NUTR-2562
MUTD-30	MCYRD-30	NUTR-30
MUTD-3072	MCYRD-3072	NUTR-3072
MUTD-35	MCYRD-35	NUTR-35
MUTD-3580	MCYRD-3580	NUTR-3580
MUTD-40	MCYRD-40	NUTR-40
MUTD-45	MCYRD-45	NUTR-45
MUTD-4090	MCYRD-4090	NUTR-4090
MUTD-50	MCYRD-50	NUTR-50
MUTD-45100	MCYRD-45100	NUTR-45100
MUTD-50110	MCYRD-50110	NUTR-50110

INTERCHANGE TABLES

Metric Cam Followers

STUD TYPE – Caged & Full Complement

SMITH®		McGILL		INA • SKF • NTN		IKO • THK	
Caged	Full Complement	Caged	Full Complement	Caged	Full Complement	Caged	Full Complement
MCR-13	MCRV-13	MCFR-13	MCF-13	–	–	CF5	–
MCR-16	MCRV-16	MCFR-16	MCF-16	KR-16	KRV-16	CF6R	CF6VR
MCR-19	MCRV-19	MCFR-19	MCF-19	KR-19	KRV-19	CF8R	CF8VR
MCR-22	MCRV-22	MCFR-22	MCF-22	KR-22	KRV-22	–	–
–	–	MCFR-22-A	MCF-22A	–	–	CF10R	CF10VR
MCR-26	MCRV-26	MCFR-26	MCF-26	KR-26	KRV-26	–	–
–	–	MCFR-26-A	MCF-26A	–	–	CF10-1R	CF10-1VR
MCR-30	MCRV-30	MCFR-30	MCF-30	KR-30	KRV-30	CF12R	CF12VR
MCR-32	MCRV-32	MCFR-32	MCF-32	KR-32	KRV-32	CF12-1R	CF12-1VR
MCR-35	MCRV-35	MCFR-35	MCF-35	KR-35	KRV-35	CF16R	CF16VR
MCR-40	MCRV-40	MCFR-40	MCF-40	KR-40	KRV-40	–	–
–	–	MCFR-40-A	MCF-40A	–	–	CF18R	CF18VR
MCR-47	MCRV-47	MCFR-47	MCF-47	KR-47	KRV-47	–	–
–	–	MCFR-47-A	MCF-47A	–	–	CF20-1R	CF20-1VR
MCR-52	MCRV-52	MCFR-52	MCF-52	KR-52	KRV-52	–	–
–	–	MCFR-52-A	MCF-52A	–	–	CF20R	CF20VR
MCR-62	MCRV-62	MCFR-62	MCF-62	KR-62	KRV-62	–	–
–	–	MCFR-62-A	MCF-62A	–	–	CF24R	CF24VR
MCR-72	MCRV-72	MCFR-72	MCF-72	KR-72	KRV-72	–	–
–	–	MCFR-72-A	MCF-72A	–	–	CF24-1R	CF24-1VR
MCR-80	MCRV-80	MCFR-80	MCF-80	KR-80	KRV-80	CF30R	CF30VR
MCR-85	MCRV-85	MCFR-85	MCF-85	KR-85	–	CF30-1R	CF30-1VR
MCR-90	MCRV-90	MCFR-90	MCF-90	KR-90	KRV-90	CF30-2R	CF30-2VR

Coding for Other Cam Followers and Yoke Roller Types

Optional Features	SMITH®	McGILL	INA • SKF	IKO	THK	NTN
Sealed	add suffix "S"	add suffix "S"	add suffix "PP"	add suffix "UU"	add suffix "UU"	add suffix "LL"
Cylindrical O.D.	add suffix "C"	add suffix "X"	add suffix "X"	remove suffix "R"	remove suffix "R"	add suffix "X"
Hex-Drive	add suffix "B"	add suffix "B"	add suffix "SK"	add suffix "B"	add suffix "A"	add suffix "H"
Eccentric	add suffix "E"	add prefix "E"	add prefix "E"	add prefix "E"		

YOKE TYPE – Caged & Full Complement

SMITH®		McGILL		INA • SKF • NTN		IKO • THK	
Caged	Full Complement	Caged	Full Complement	Caged	Full Complement	Caged	Full Complement
MYR-5	MYRV-5	MCYRR-5	MCYR-5	NATR-5	NATV-5	NART-5R	NART-5VR
MYR-6	MYRV-6	MCYRR-6	MCYR-6	NATR-6	NATV-6	NART-6R	NART-6VR
MYR-8	MYRV-8	MCYRR-8	MCYR-8	NATR-8	NATV-8	NART-8R	NART-8VR
MYR-10	MYRV-10	MCYRR-10	MCYR-10	NATR-10	NATV-10	NART-10R	NART-10VR
MYR-12	MYRV-12	MCYRR-12	MCYR-12	NATR-12	NATV-12	NART-12R	NART-12VR
MYR-15	MYRV-15	MCYRR-15	MCYR-15	NATR-15	NATV-15	NART-15R	NART-15VR
MYR-17	MYRV-17	MCYRR-17	MCYR-17	NATR-17	NATV-17	NART-17R	NART-17VR
MYR-20	MYRV-20	MCYRR-20	MCYR-20	NATR-20	NATV-20	NART-20R	NART-20VR
MYR-25	MYRV-25	MCYRR-25	MCYR-25	NATR-25	NATV-25	NART-25R	NART-25VR
MYR-30	MYRV-30	MCYRR-30	MCYR-30	NATR-30	NATV-30	NART-30R	NART-30VR
MYR-35	MYRV-35	MCYRR-35	MCYR-35	NATR-35	NATV-35	NART-35R	NART-35VR
MYR-40	MYRV-40	MCYRR-40	MCYR-40	NATR-40	NATV-40	NART-40R	NART-40VR
MYR-45	MYRV-45	MCYRR-45	MCYR-45	NATR-45	–	NART-45R	NART-45VR
MYR-50	MYRV-50	MCYRR-50	MCYR-50	NATR-50	NATV-50	NART-50R	NART-50VR



# Smith-Trax®

INCH & METRIC SIZES

## Introduction

**SMITH-TRAX®** were designed for applications with a combination of both radial and axial loads. The **SMITH-TRAX®** Bearings use tapered roller bearings or deep groove ball bearings to handle this combination of radial and thrust loads. This bearing system is considerably more effective at supporting axial loads than needle rollers found in standard cam followers.

Special seals are used in **SMITH-TRAX®** Bearings so they can be used in contaminated environments. A metal expansion plug closes off the back end of the bearing to allow for a large lubrication reservoir.

**SMITH-TRAX®** Bearings are available in Inch and Metric sizes in Stud or Yoke Type versions. There are 4 different configurations available to meet a wide range of applications available:

**Plain O.D.** Handle thrust or radial loads. Load can ride against O.D. or face of bearing.

**Flanged O.D.** Designed for side guiding, where the intended load can ride up against the flange.

**V-Groove** Designed for operation on V-shaped tracks. V-shaped tracks will not allow contaminants to build up as easily as they would on a flat and level track.

**U-Groove** Are commonly used for wire guiding applications and are custom made to order.

**PCR** Plain Stud Type



**FCR** Flange Stud Type



**VCR** V-Grooved Stud Type



**UCR** U-Grooved Stud Type



**PYR** Plain Yoke Type

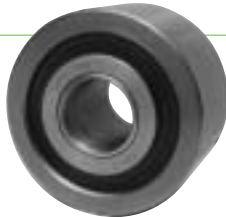

**FYR** Flanged Yoke Type



**VYR** V-Grooved Yoke Type



# Inch Sizes Smith-Trax®

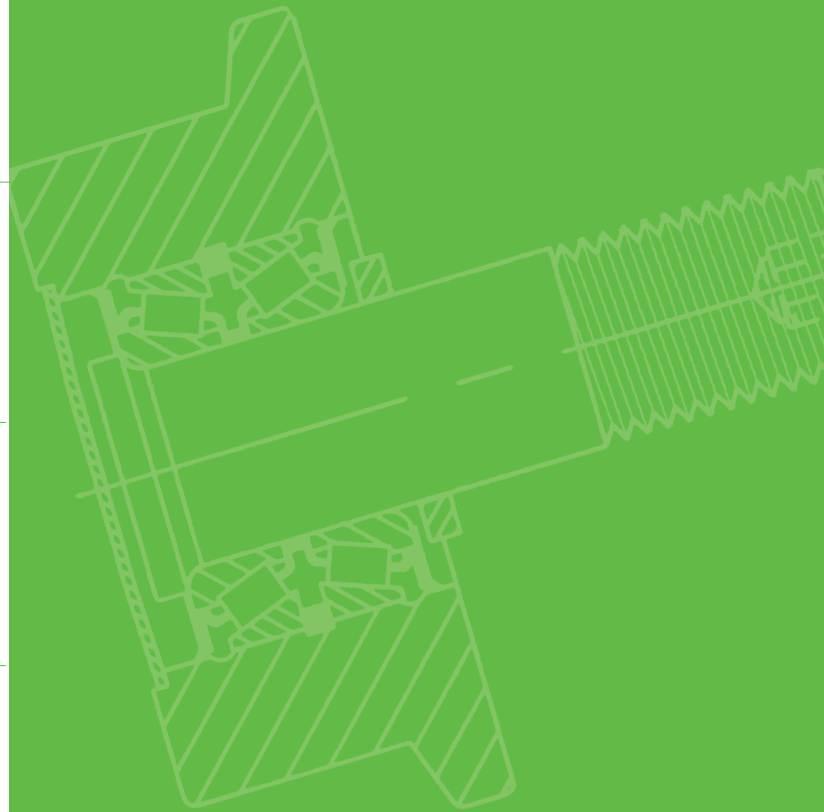

**PCR**  
**Plain Stud Type**

SMITH-TRAX®

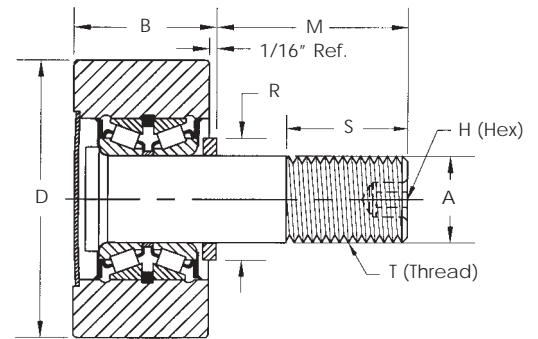

**General Information**

The **Smith-Trax®** Series bearings are designed and manufactured to handle increased axial and radial loads by using **Tapered Roller Bearings** or **Deep Groove Ball Bearings**. These bearings should be used when standard needle roller bearings are not sufficient to handle the thrust load found in certain applications. Consult our Engineering Department for special requirements.

Dimensional Data (inches)

SMITH Bearing® Number	BEARING TYPE TRB-Tapered Roller Bearing BB-Ball Bearing	D Roller O.D. +.000 -.001	B Roller Width	A Stud Diameter +.001 -.000	M Stud Length	S Eff. Thread Min	T Thread U.N.F. Class 2A	H Hex Size	R Shoulder Width or End Plate Diameter	Radial Basic Dynamic Rating (lbs) 500 hrs. 33 rpm.	Dynamic Thrust Load Rating (lbs) 500 hrs. 33 rpm.	Max Static Capacity (lbs)
PCR-1½	BB	1.500	1.187	.625	1½	¾	5/8-18	5/16	0.750	2,520	1,320	1,370
PCR-1¾	BB	1.750	1.187	.750	1¾	7/8	3/4-16	5/16	1.000	2,520	1,320	1,370
PCR-2	BB	2.000	1.687	.875	2	1 1/8	7/8-14	5/16	1.000	3,490	1,830	2,000
PCR-2¼	BB	2.250	1.687	.875	2	1 1/8	7/8-14	5/16	1.000	3,490	1,830	2,000
PCR-2½	BB	2.500	1.687	1.000	2¼	1 1/2	1-14	7/16	1.250	5,120	2,680	3,120
PCR-2¾	BB	2.750	1.687	1.000	2¼	1 1/2	1-14	7/16	1.250	5,120	2,680	3,120
PCR-3	TRB	3.000	2.000	1.250	2½	1¾	1¼-12	1/2	1.750	14,300	5,790	16,000
PCR-3¼	TRB	3.250	2.000	1.250	2½	1¾	1¼-12	1/2	1.750	14,300	5,790	16,000
PCR-3½	TRB	3.500	2.000	1.250	2¾	1¾	1¼-12	1/2	1.750	14,300	5,790	16,000
PCR-4	TRB	4.000	2.000	1.250	2¾	1¾	1¼-12	1/2	1.750	14,300	5,790	16,000
PCR-4½	TRB	4.500	2.000	1.250	2¾	1¾	1¼-12	1/2	1.750	14,300	5,790	16,000
PCR-5	TRB	5.000	3.000	2.000	4½	2½	2-12	5/8	3.250	35,800	13,300	40,000
PCR-6	TRB	6.000	3.000	2.500	5½	3¼	2½-12	5/8	3.250	35,800	14,200	62,000
PCR-7	TRB	7.000	3.000	2.500	5½	3¼	2½-12	5/8	3.250	35,800	14,200	62,000
PCR-8	TRB	8.000	3.000	2.500	5½	3¼	2½-12	5/8	3.250	35,800	14,200	62,000

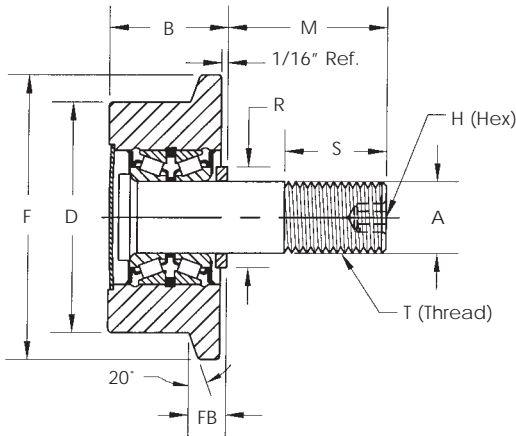

**FCR**

**Flanged Stud Type**

SMITH-TRAX®

**General Information**

The **Smith-Trax®** Series bearings are designed and manufactured to handle increased axial and radial loads by using **Tapered Roller Bearings** or **Deep Groove Ball Bearings**. These bearings should be used when standard needle roller bearings are not sufficient to handle the thrust load found in certain applications. Consult our Engineering Department for special requirements.

Dimensional Data (inches)

SMITH Bearing® Number	BEARING TYPE TRB-Tapered Roller Bearing BB-Ball Bearing	D	F	B	FB	A	M	S	T	H	R	Radial Basic Dynamic Rating (lbs) 500 hrs. 33 rpm.	Dynamic Thrust Load Rating (lbs) 500 hrs. 33 rpm.	Max Static Capacity (lbs)
		Roller O.D.	Flange O.D.	Roller Width	Flange Width	Stud Dia. +.000 -.001	Stud Length	Eff. Thread Min	Thread U.N.F. Class 2A	Hex Size	Shoulder or End Plate Dia.			
FCR-1½	BB	1.500	2 <sup>3</sup> / <sub>16</sub>	1 <sup>3</sup> / <sub>16</sub>	1 <sup>1</sup> / <sub>32</sub>	.625	1½	3/4	5/8-18	5/16	3/4	2,520	1,320	1,370
FCR-1¾	BB	1.750	2 <sup>7</sup> / <sub>16</sub>	1 <sup>11</sup> / <sub>16</sub>	1 <sup>1</sup> / <sub>32</sub>	.750	1¾	7/8	3/4-16	5/16	1	2,520	1,320	1,370
FCR-2	BB	2.000	2 <sup>11</sup> / <sub>16</sub>	1 <sup>11</sup> / <sub>16</sub>	1 <sup>9</sup> / <sub>32</sub>	.875	2	1½/8	7/8-14	5/16	1	3,490	1,830	2,000
FCR-2¼	BB	2.250	2 <sup>15</sup> / <sub>16</sub>	1 <sup>11</sup> / <sub>16</sub>	1 <sup>9</sup> / <sub>32</sub>	.875	2	1½/8	7/8-14	5/16	1	3,490	1,830	2,000
FCR-2½	BB	2.500	3 <sup>3</sup> / <sub>16</sub>	1 <sup>11</sup> / <sub>16</sub>	1 <sup>9</sup> / <sub>32</sub>	1.000	2¼	1½/2	1-14	7/16	1¼/4	5,120	2,680	3,120
FCR-2¾	BB	2.750	3 <sup>7</sup> / <sub>16</sub>	1 <sup>11</sup> / <sub>16</sub>	1 <sup>9</sup> / <sub>32</sub>	1.000	2¼	1½/2	1-14	7/16	1¼/4	5,120	2,680	3,120
FCR-3	TRB	3.000	3 <sup>15</sup> / <sub>16</sub>	2	1 <sup>9</sup> / <sub>32</sub>	1.250	2½	1¾/4	1¼/4-12	1/2	1¾/4	14,300	5,790	16,000
FCR-3¼	TRB	3.250	4 <sup>3</sup> / <sub>16</sub>	2	1 <sup>9</sup> / <sub>32</sub>	1.250	2½	1¾/4	1¼/4-12	1/2	1¾/4	14,300	5,790	16,000
FCR-3½	TRB	3.500	4 <sup>7</sup> / <sub>16</sub>	2	1 <sup>9</sup> / <sub>32</sub>	1.250	2¾/4	1¾/4	1¼/4-12	1/2	1¾/4	14,300	5,790	16,000
FCR-4	TRB	4.000	4 <sup>15</sup> / <sub>16</sub>	2	1 <sup>9</sup> / <sub>32</sub>	1.250	2¾/4	1¾/4	1¼/4-12	1/2	1¾/4	14,300	5,790	16,000
FCR-4½	TRB	4.500	5 <sup>7</sup> / <sub>16</sub>	2	1 <sup>9</sup> / <sub>32</sub>	1.250	2¾/4	1¾/4	1¼/4-12	1/2	1¾/4	14,300	5,790	16,000
FCR-5	TRB	5.000	5 <sup>15</sup> / <sub>16</sub>	3	2 <sup>3</sup> / <sub>32</sub>	2.000	4½	2½/2	2-12	5/8	3¼/4	35,800	13,300	40,000
FCR-6	TRB	6.000	6 <sup>15</sup> / <sub>16</sub>	3	2 <sup>3</sup> / <sub>32</sub>	2.500	5½	3¼/4	2½/2-12	5/8	3¼/4	35,800	14,200	62,000
FCR-7	TRB	7.000	7 <sup>15</sup> / <sub>16</sub>	3	2 <sup>3</sup> / <sub>32</sub>	2.500	5½	3¼/4	2½/2-12	5/8	3¼/4	35,800	14,200	62,000
FCR-8	TRB	8.000	8 <sup>15</sup> / <sub>16</sub>	3	2 <sup>3</sup> / <sub>32</sub>	2.500	5½	3¼/4	2½/2-12	5/8	3¼/4	35,800	14,200	62,000

**VCR**  
**V-Groove Stud Type**

SMITH-TRAX®

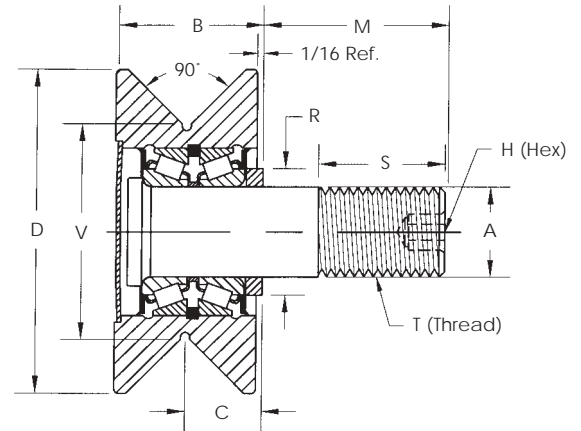

**General Information**

The **Smith-Trax®** Series bearings are designed and manufactured to handle increased axial and radial loads by using **Tapered Roller Bearings** or **Deep Groove Ball Bearings**. These bearings should be used when standard needle roller bearings are not sufficient to handle the thrust load found in certain applications. Consult our Engineering Department for special requirements.

Dimensional Data (inches)

SMITH Bearing® Number	BEARING TYPE	D Outside Roller O.D.	V Point Dia.	B Roller Width	C Groove Center	A Stud Dia. +.001 -0.000	M Stud Length	S Eff. Thread Min	T Thread U.N.F. Class 2A	H Hex Size	R Shoulder or End Plate Dia.	Radial Basic Dynamic Rating (lbs) 500 hrs. 33 rpm.	Dynamic Thrust Load Rating (lbs) 500 hrs. 33 rpm.	Max Static Capacity (lbs)
	TRB-Tapered Roller Bearing BB-Ball Bearing													
VCR-3½	BB	3.500	2.250	1 <sup>11</sup> / <sub>16</sub>	7/8	0.875	2	1 <sup>1</sup> / <sub>8</sub>	7/8-14	5/16	1	3,490	1,830	2,000
VCR-4½	TRB	4.500	3.000	2	1	1.250	2 <sup>1</sup> / <sub>2</sub>	1 <sup>3</sup> / <sub>4</sub>	1 <sup>1</sup> / <sub>4</sub> -12	1/2	1 <sup>3</sup> / <sub>4</sub>	14,300	5,790	16,000
VCR-5½	TRB	5.500	4.000	2	1	1.250	2 <sup>3</sup> / <sub>4</sub>	1 <sup>3</sup> / <sub>4</sub>	1 <sup>1</sup> / <sub>4</sub> -12	1/2	1 <sup>3</sup> / <sub>4</sub>	15,300	5,790	16,000
VCR-6½	TRB	6.500	5.000	3	1 <sup>1</sup> / <sub>2</sub>	2.000	4 <sup>1</sup> / <sub>2</sub>	2 <sup>1</sup> / <sub>2</sub>	2-12	5/8	3 <sup>1</sup> / <sub>4</sub>	35,800	13,300	40,000
VCR-7½	TRB	7.500	6.000	3	1 <sup>1</sup> / <sub>2</sub>	2.500	5 <sup>1</sup> / <sub>2</sub>	3 <sup>1</sup> / <sub>4</sub>	2 <sup>1</sup> / <sub>2</sub> -12	5/8	3 <sup>1</sup> / <sub>4</sub>	35,800	14,200	62,000
VCR-8½	TRB	8.500	7.000	3	1 <sup>1</sup> / <sub>2</sub>	2.500	5 <sup>1</sup> / <sub>2</sub>	3 <sup>1</sup> / <sub>4</sub>	2 <sup>1</sup> / <sub>2</sub> -12	5/8	3 <sup>1</sup> / <sub>4</sub>	35,800	14,200	62,000

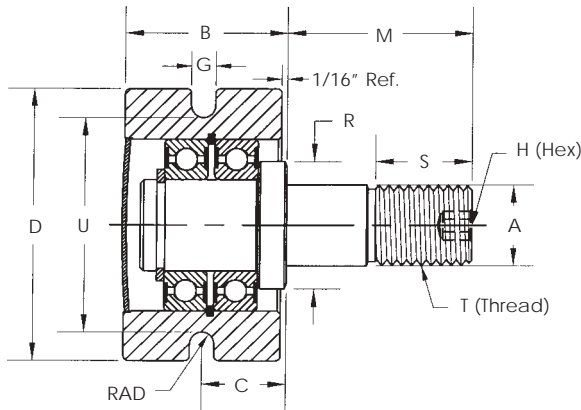

**UCR**

**U-Grooved Stud Type**

SMITH-TRAX®

**General Information**

The **Smith-Trax®** Series bearings are designed and manufactured to handle increased axial and radial loads by using **Tapered Roller Bearings** or **Deep Groove Ball Bearings**. These bearings should be used when standard needle roller bearings are not sufficient to handle the thrust load found in certain applications. Consult our Engineering Department for special requirements.

Dimensional Data (inches)

SMITH Bearing® Number	BEARING TYPE	D	U	B	C	G	RAD	A	M	S	T	H	R	Radial Basic Dynamic Rating (lbs) 500 hrs. 33 rpm.	Dynamic Thrust Load Rating (lbs) 500 hrs. 33 rpm.	Max Static Capacity (lbs)
	BB-Ball Bearing	Outside Roller O.D.	Groove Dia.	Roller Width	Groove Center	Groove Width	Groove Radius	Stud Dia. +.000 -0.001	Stud Length	Eff. Thread Min	Thread U.N.F. Class 2A	Hex Size	Shoulder or End Plate Dia.			
UCR-215/16 - 1	BB	2 <sup>15</sup> / <sub>16</sub>	2 <sup>5</sup> / <sub>16</sub>	1 <sup>11</sup> / <sub>16</sub>	7/8	.263	0.1315	0.875	2	1 <sup>1</sup> / <sub>8</sub>	7/8-14	3/8	1	3,490	1,830	2,000
UCR-215/16 - 2	BB	2 <sup>15</sup> / <sub>16</sub>	2 <sup>5</sup> / <sub>16</sub>	1 <sup>11</sup> / <sub>16</sub>	7/8	.242	0.1210	0.875	2	1 <sup>1</sup> / <sub>8</sub>	7/8-14	3/8	1	3,490	1,830	2,000
UCR-215/16 - 3	BB	2 <sup>15</sup> / <sub>16</sub>	2 <sup>3</sup> / <sub>8</sub>	1 <sup>11</sup> / <sub>16</sub>	7/8	.224	0.1120	0.875	2	1 <sup>1</sup> / <sub>8</sub>	7/8-14	3/8	1	3,490	1,830	2,000
UCR-215/16 - 4	BB	2 <sup>15</sup> / <sub>16</sub>	2 <sup>3</sup> / <sub>8</sub>	1 <sup>11</sup> / <sub>16</sub>	7/8	.207	0.1035	0.875	2	1 <sup>1</sup> / <sub>8</sub>	7/8-14	3/8	1	3,490	1,830	2,000
UCR-215/16 - 5	BB	2 <sup>15</sup> / <sub>16</sub>	2 <sup>7</sup> / <sub>16</sub>	1 <sup>11</sup> / <sub>16</sub>	7/8	.184	0.0920	0.875	2	1 <sup>1</sup> / <sub>8</sub>	7/8-14	3/8	1	3,490	1,830	2,000
UCR-215/16 - 6	BB	2 <sup>15</sup> / <sub>16</sub>	2 <sup>1</sup> / <sub>2</sub>	1 <sup>11</sup> / <sub>16</sub>	7/8	.169	0.0845	0.875	2	1 <sup>1</sup> / <sub>8</sub>	7/8-14	3/8	1	3,490	1,830	2,000
UCR-215/16 - 7	BB	2 <sup>15</sup> / <sub>16</sub>	2 <sup>1</sup> / <sub>2</sub>	1 <sup>11</sup> / <sub>16</sub>	7/8	.152	0.0760	0.875	2	1 <sup>1</sup> / <sub>8</sub>	7/8-14	3/8	1	3,490	1,830	2,000
UCR-215/16 - 8	BB	2 <sup>15</sup> / <sub>16</sub>	2 <sup>9</sup> / <sub>16</sub>	1 <sup>11</sup> / <sub>16</sub>	7/8	.138	0.0690	0.875	2	1 <sup>1</sup> / <sub>8</sub>	7/8-14	3/8	1	3,490	1,830	2,000
UCR-215/16 - 9	BB	2 <sup>15</sup> / <sub>16</sub>	2 <sup>5</sup> / <sub>8</sub>	1 <sup>11</sup> / <sub>16</sub>	7/8	.124	0.0620	0.875	2	1 <sup>1</sup> / <sub>8</sub>	7/8-14	3/8	1	3,490	1,830	2,000
UCR-215/16 - 10	BB	2 <sup>15</sup> / <sub>16</sub>	2 <sup>5</sup> / <sub>8</sub>	1 <sup>11</sup> / <sub>16</sub>	7/8	.113	0.0565	0.875	2	1 <sup>1</sup> / <sub>8</sub>	7/8-14	3/8	1	3,490	1,830	2,000



**PYR**

**Plain Yoke Type**

SMITH-TRAX®

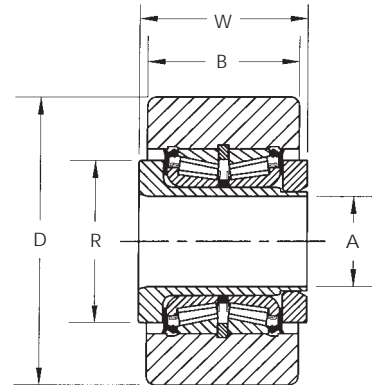

**General Information**

The **Smith-Trax®** Series bearings are designed and manufactured to handle increased axial and radial loads by using **Tapered Roller Bearings** or **Deep Groove Ball Bearings**. These bearings should be used when standard needle roller bearings are not sufficient to handle the thrust load found in certain applications. Consult our Engineering Department for special requirements.

Dimensional Data (inches)

SMITH Bearing® Number	BEARING TYPE TRB-Tapered Roller Bearing	D Roller O.D. +.000 -.001	B Roller Width	A Bore Diameter +.0005 * -.0000	W Overall Width +.005 -.010	R Shoulder or End Plate Diameter	Radial Basic Dynamic Rating (lbs) 500 hrs. 33 rpm.	Dynamic Thrust Load Rating(lbs) 500 hrs. 33 rpm.
PYR-3	TRB	3.000	1.750	1.000	1.813	1 <sup>3</sup> / <sub>4</sub>	14,300	5,790
PYR-3 <sup>1</sup> / <sub>4</sub>	TRB	3.250	1.750	1.000	1.813	1 <sup>3</sup> / <sub>4</sub>	14,300	5,790
PYR-3 <sup>1</sup> / <sub>2</sub>	TRB	3.500	2.000	1.125	2.063	2	17,600	5,790
PYR-4	TRB	4.000	2.250	1.250	2.313	2 <sup>1</sup> / <sub>2</sub>	17,600	5,790
PYR-5	TRB	5.000	2.750	1.750	2.875	3 <sup>1</sup> / <sub>2</sub>	33,300	13,300
PYR-6	TRB	6.000	3.250	2.250	3.375	3 <sup>1</sup> / <sub>2</sub>	35,800	14,200
PYR-7	TRB	7.000	3.750	*2.750	3.875	4 <sup>1</sup> / <sub>4</sub>	42,400	17,400
PYR-8	TRB	8.000	4.250	*3.255	4.500	4 <sup>3</sup> / <sub>4</sub>	83,700	39,000

\*Tolerance on "A" Bore Diameter for PYR-7 and PYR-8 is (+0.001/-0.000)



**FYR**

**Flanged Yoke Type**

SMITH-TRAX®

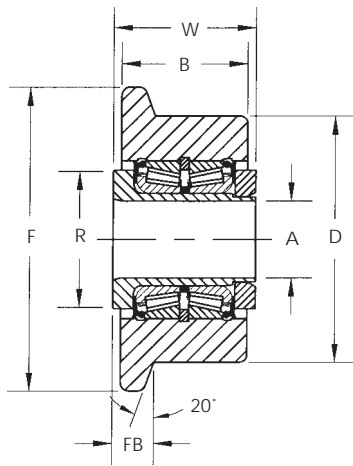

**General Information**

The **Smith-Trax®** Series bearings are designed and manufactured to handle increased axial and radial loads by using **Tapered Roller Bearings** or **Deep Groove Ball Bearings**. These bearings should be used when standard needle roller bearings are not sufficient to handle the thrust load found in certain applications. Consult our Engineering Department for special requirements.

Dimensional Data (inches)

SMITH Bearing® Number	BEARING TYPE TRB-Tapered Roller Bearing	D Roller O.D.	F Flange O.D.	B Roller Width	FB Flange Width	A Bore Diameter +.0005* -.0000	W Overall Width +.005 -.010	R Shoulder or End Plate Diameter	Radial Basic Dynamic Rating (lbs) 500 hrs. 33 rpm.	Dynamic Thrust Load Rating (lbs) 500 hrs. 33 rpm.
FYR-3	TRB	3.000	3 <sup>15</sup> / <sub>16</sub>	1.750	19/32	1.000	1.812	1 <sup>3</sup> / <sub>4</sub>	14,300	5,790
FYR-3 <sup>1</sup> / <sub>4</sub>	TRB	3.250	4 <sup>3</sup> / <sub>16</sub>	1.750	19/32	1.000	1.812	1 <sup>3</sup> / <sub>4</sub>	14,300	5,790
FYR-3 <sup>1</sup> / <sub>2</sub>	TRB	3.500	4 <sup>7</sup> / <sub>16</sub>	2.000	19/32	1.125	2.062	2	17,600	5,790
FYR-4	TRB	4.000	4 <sup>15</sup> / <sub>16</sub>	2.250	19/32	1.250	2.312	2 <sup>1</sup> / <sub>4</sub>	17,600	5,790
FYR-5	TRB	5.000	5 <sup>15</sup> / <sub>16</sub>	2.750	23/32	1.750	2.875	3 <sup>1</sup> / <sub>2</sub>	33,300	13,300
FYR-6	TRB	6.000	6 <sup>15</sup> / <sub>16</sub>	3.250	23/32	2.250	3.375	3 <sup>1</sup> / <sub>2</sub>	35,800	14,200
FYR-7	TRB	7.000	7 <sup>15</sup> / <sub>16</sub>	3.750	23/32	*2.750	3.875	4 <sup>1</sup> / <sub>4</sub>	42,400	17,400
FYR-8	TRB	8.000	8 <sup>15</sup> / <sub>16</sub>	4.250	23/32	*3.255	4.500	4 <sup>3</sup> / <sub>4</sub>	83,700	39,000

\*Tolerance on "A" Bore Diameter for FYR-7 and FYR-8 is (+0.001/-0.000)

**VYR**

**V-Groove Yoke Style**

SMITH-TRAX®

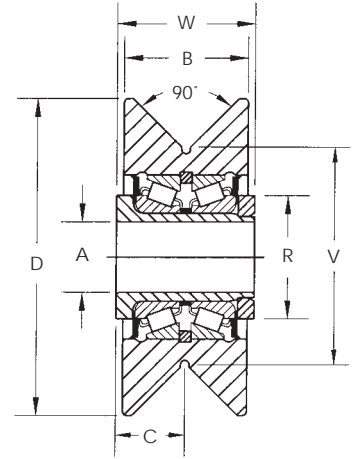

**General Information**

The **Smith-Trax®** Series bearings are designed and manufactured to handle increased axial and radial loads by using **Tapered Roller Bearings** or **Deep Groove Ball Bearings**. These bearings should be used when standard needle roller bearings are not sufficient to handle the thrust load found in certain applications. Consult our Engineering Department for special requirements.

Dimensional Data (inches)

SMITH Bearing® Number	BEARING TYPE	D Roller O.D.	B Roller Width	A Bore Diameter +.0005 * -.0000	W Overall Width +.005 -.010	V Point Diameter	C Groove Center	R Shoulder or End Plate Diameter 33 rpm.	Radial Basic Dynamic Rating (lbs) 500 hrs. 33 rpm.	Dynamic Thrust Load Rating (lbs) 500 hrs.
VYR-4 <sup>1</sup> / <sub>2</sub>	TRB	4.500	1.750	1.000	1.813	3.000	0.906	1.75	14,300	5,790
VYR-5	TRB	5.000	2.000	1.125	2.063	3.500	1.031	2.00	17,600	5,790
VYR-5 <sup>1</sup> / <sub>2</sub>	TRB	5.500	2.250	1.250	2.313	4.000	1.156	2.25	17,600	5,790
VYR-6 <sup>1</sup> / <sub>2</sub>	TRB	6.500	2.750	1.750	2.875	5.000	1.438	3.50	35,800	14,200
VYR-7 <sup>1</sup> / <sub>2</sub>	TRB	7.500	3.250	2.250	3.375	6.000	1.688	3.50	35,800	14,200
VYR-8 <sup>1</sup> / <sub>2</sub>	TRB	8.500	3.750	*2.750	3.875	7.000	1.938	4.25	42,400	17,400

\*Tolerance on "A" Bore Diameter for VYR-8<sup>1</sup>/<sub>2</sub> is (+0.001/-0.000)

**MPCR** Plain Stud Type



**MFCR** Flange Stud Type

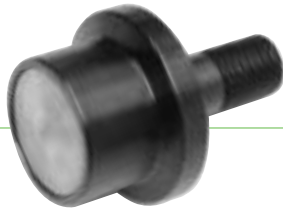

**MVCR** V-Grooved Stud Type



**MPYR** Plain Yoke Type



**MFYR** Flanged Yoke Type

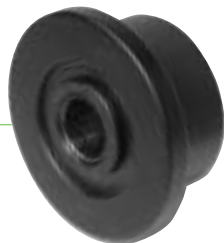

**MVYR** V-Grooved Yoke Type



# Metric Sizes Smith-Trax®

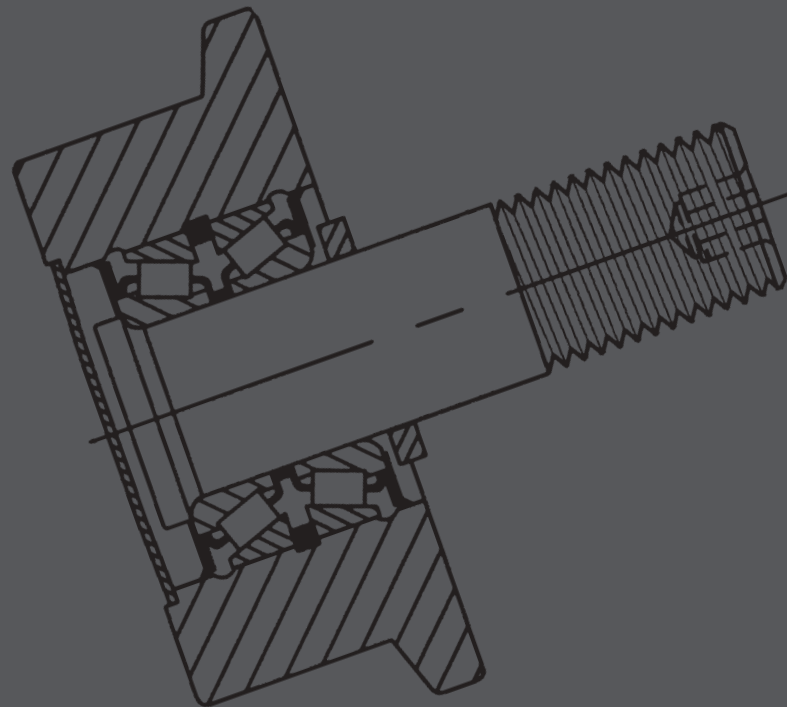

**MPCR**

**Plain Stud Style**

SMITH-TRAX®

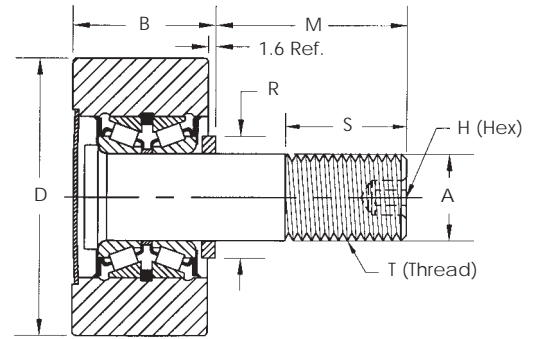

**General Information**

The **Smith-Trax®** Series bearings are designed and manufactured to handle increased axial and radial loads by using **Tapered Roller Bearings** or **Deep Groove Ball Bearings**. These bearings should be used when standard needle roller bearings are not sufficient to handle the thrust load found in certain applications. Consult our Engineering Department for special requirements.

Dimensional Data (mm)

SMITH Bearing® Number	BEARING TYPE	D Roller O.D.	B Roller Width	A Stud Diameter	M Stud Length	S Eff. Thread Min	T Thread	H Hex Size	R Shoulder Width or End Plate Diameter	Radial Basic Dynamic Rating (N) 500 hrs. 33 rpm.	Dynamic Thrust Load Rating (N) 500 hrs. 33 rpm.	Max Static Capacity (N)
	TRB-Tapered Roller Bearing BB-Ball Bearing	+0.00 -0.02		+0.00 -0.02								
MPCR-26	BB	26	20.0	10	23.0	13	M10 X 1	4	13.1	2,790	1,720	1,000
MPCR-30	BB	30	20.0	12	25.0	14	M12 X 1.5	4	15.9	2,790	1,720	1,000
MPCR-32	BB	32	22.0	12	25.0	14	M12 X 1.5	8	15.9	6,000	3,700	2,680
MPCR-35	BB	35	22.0	16	32.5	18	M16 X 1.5	8	19.1	6,000	3,700	2,680
MPCR-40	BB	40	30.0	14	40.0	26	M14 X 2	8	18.0	12,200	7,560	4,900
MPCR-47	BB	47	27.6	20	40.5	21	M20 X 1.5	8	25.5	12,200	7,560	4,900
MPCR-50	TRB	50	40.0	16	50.0	35	M16 X 2	8	23.0	17,000	10,600	7,200
MPCR-52	TRB	52	33.6	20	40.5	21	M20 X 1.5	8	25.5	17,000	10,600	7,200
MPCR-62	TRB	62	44.0	24	58.0	35	M24 X 3	8	32.0	23,100	14,200	10,100
MPCR-72	TRB	72	44.0	24	49.5	25	M24 X 1.5	8	32.0	48,400	17,840	33,900
MPCR-76	TRB	76	52.0	30	69.5	40	M30 X 3.5	8	44.5	63,600	25,700	89,000
MPCR-80	TRB	80	52.0	30	69.5	40	M30 X 3.5	8	44.5	63,600	25,700	89,000
MPCR-85	TRB	85	52.0	30	69.5	40	M30X 3.5	8	44.5	63,600	25,700	89,000
MPCR-90	TRB	90	52.0	30	69.5	40	M30X 3.5	8	44.5	63,600	25,700	89,000
MPCR-100	TRB	100	52.0	30	80.0	50	M30X 3.5	8	44.5	63,600	25,700	89,000
MPCR-125	TRB	125	76.0	48	105.0	60	M48 X 5	12	82.5	148,100	58,500	238,000
MPCR-150	TRB	150	76.0	64	140.0	82	M64 X 6	12	82.5	159,000	63,000	251,000
MPCR-200	TRB	200	76.0	64	140.0	82	M64 X 6	12	82.5	159,000	63,000	251,000

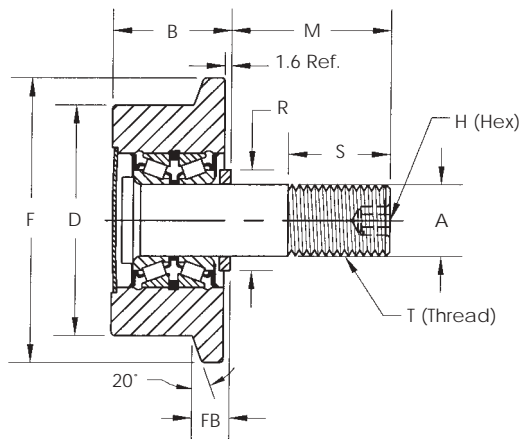

**MFCR**  
**Flanged Stud Type**

SMITH-TRAX®

**General Information**

The **Smith-Trax®** Series bearings are designed and manufactured to handle increased axial and radial loads by using **Tapered Roller Bearings** or **Deep Groove Ball Bearings**. These bearings should be used when standard needle roller bearings are not sufficient to handle the thrust load found in certain applications. Consult our Engineering Department for special requirements.

Dimensional Data (mm)

SMITH Bearing® Number	BEARING TYPE	D Roller O.D.	F Flange O.D.	B Roller Width	FB Flange Width	A Stud Dia. +0.00 -0.02	M Stud Length	S Eff. Thread Min.	T Thread	H Hex Size	R Shoulder or End Plate Dia.	Radial Basic Dynamic Rating (N) 500 hrs. 33 rpm.	Dynamic Thrust Load Rating (N) 500 hrs. 33 rpm.	Max Static Capacity (N)
	TRB-Tapered Roller Bearing													
MFCR-26	BB	26	35	20	5	10,000	23	13	M10 x 1	4	13.1	2,790	1,720	1,000
MFCR-30	BB	30	40	20	5	12,000	25	14	M1 x 1.5	4	15.9	2,790	1,720	1,000
MFCR-32	BB	32	42	23	5	12,000	25	14	M12x 1.5	8	15.9	6,000	3,700	2,680
MFCR-35	BB	35	46	23	5	16,000	32.55	18	M16x 1.5	8	19.1	6,000	3,700	2,680
MFCR-40	BB	40	54	30.0	8.8	146,000	40	26	M14 x 2	8	18	12,200	7,560	4,900
MFCR-47	TRB	47	61	27.6	7.8	20,000	40.5	21	M20x1.5	8	25.5	12,200	7,560	4,900
MFCR-50	TRB	50	68	40	14	16,000	50	35	M16 x 2	8	23	17,000	10,600	7,200
MFCR-52	TRB	52	66	33.6	10.8	20,000	40.5	21	M20x1.5	8	25.5	17,000	10,600	7,200
MFCR-62	TRB	62	78	44	14	24,000	58	35	M24 x 3	8	32	23,100	14,200	10,100
MFCR-72	TRB	72	90	44	14	24,000	49.5	25	M24 x 3	8	32	23,100	14,200	10,100
MFCR-76	TRB	76	98	52	14	30,000	69.5	40	M30x3.5	8	44.5	63,600	25,700	89,000
MFCR-80	TRB	80	102	52	14	30,000	69.5	40	M30x3.5	8	44.5	63,600	25,700	89,000
MFCR-85	TRB	85	107	52	14	30,000	69.5	40	M30x3.5	8	44.5	63,600	25,700	89,900
MFCR-90	TRB	90	112	52	14	30,000	69.5	40	M30x3.5	8	44.5	63,600	25,700	89,900
MFCR-100	TRB	100	125	52	14	30,000	80	50	M30x3.5	8	44.5	63,600	25,700	89,900
MFCR-125	TRB	125	148	76	18	48,000	105	60	M48 x 5	12	82.5	148,100	58,500	230,800
MFCR-150	TRB	150	173	76	18.3	64,000	140	82	M64 x 6	12	82.5	159,000	63,000	251,000
MFCR-200	TRB	200	223	76	18.3	64,000	140	82	M64 x 6	12	82.5	159,000	63,000	251,000

**MVCR**  
**V-Groove Stud Style**

SMITH-TRAX®

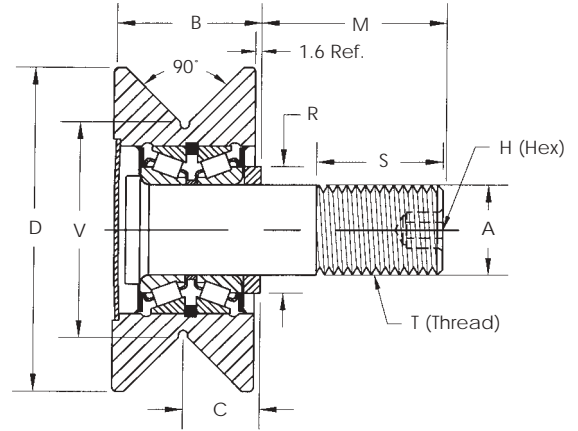

**General Information**

The **Smith-Trax®** Series bearings are designed and manufactured to handle increased axial and radial loads by using **Tapered Roller Bearings** or **Deep Groove Ball Bearings**. These bearings should be used when standard needle roller bearings are not sufficient to handle the thrust load found in certain applications. Consult our Engineering Department for special requirements.

Dimensional Data (mm)

SMITH Bearing® Number	BEARING TYPE	D Outside Roller O.D.	V Point Dia.	B Roller Width	C Groove Center	A Stud Dia. +0.00 -0.02	M Stud Length	S Eff. Thread Min.	T Thread	H Hex Size	R Shoulder or End Plate Dia.	Radial Basic Dynamic Rating (N) 500 hrs. 33 rpm.	Dynamic Thrust Load Rating (N) 500 hrs. 33 rpm.	Max Static Capacity (N)
	TRB-Tapered Roller Bearing BB-Ball Bearing													
MVCR-26	BB	40	26	20	10	10	23.0	13	M10 x 1	4	13.1	2,790	1,720	1,000
MVCR-32	BB	50	32	22	11	12	25.0	14	M12 x 1.5	8	15.9	6,000	3,700	2,680
MVCR-40	BB	60	40	33	17	17	40.0	26	M14 x 2	8	18	6,000	3,700	2,680
MVCR-62	TRB	90	62	44.5	23	24	58.0	35	M24 x 3	8	32	23,100	14,200	10,100
MVCR-76	TRB	120	76	50.5	26	30	69.5	40	M30 x 3.5	8	44.5	63,600	25,700	89,000
MVCR-100	TRB	140	100	50.5	26	30	80.0	50	M30 x 3.5	8	44.5	63,600	25,700	89,000
MVCR-125	TRB	165	125	76	37.8	48	105.0	50	M48 x 5	12	82.5	148,100	58,500	230,800

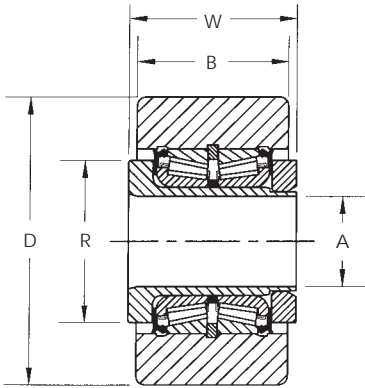

**MPYR**  
**Plain Yoke Style**  
 SMITH-TRAX®

**General Information**

The **Smith-Trax®** Series bearings are designed and manufactured to handle increased axial and radial loads by using **Tapered Roller Bearings** or **Deep Groove Ball Bearings**. These bearings should be used when standard needle roller bearings are not sufficient to handle the thrust load found in certain applications. Consult our Engineering Department for special requirements.

Dimensional Data (mm)

SMITH Bearing® Number	BEARING TYPE TRB-Tapered Roller Bearing	D Roller O.D. +0.00 -0.02	B Roller Width	A Bore Diameter +0.00 -0.02	W Overall Width	R Shoulder or End Plate Diameter	Radial Basic Dynamic Rating (N) 500 hrs. 33 rpm.	Dynamic Thrust Load Rating (N) 500 hrs. 33 rpm.
MPYR-62	TRB	62	38	20	40	32.00	48,400	17,800
MPYR-76	TRB	76	44	25	46	44.50	63,500	25,700
MPYR-80	TRB	80	44	25	46	44.50	63,500	25,700
MPYR-85	TRB	85	44	25	46	44.50	63,500	25,700
MPYR-90	TRB	90	54	30	56	57.20	78,200	25,600
MPYR-100	TRB	100	54	30	56	57.20	78,200	25,600
MPYR-125	TRB	125	68	45	71	82.60	148,100	58,500
MPYR-150	TRB	150	70	55	73	88.90	159,000	63,000
MPYR-200	TRB	125	68	45	71	82.60	148,100	58,500
MPYR-250	TRB	150	70	55	73	88.90	159,000	63,000



**MFYR**

**Flange Yoke Style**

SMITH-TRAX®

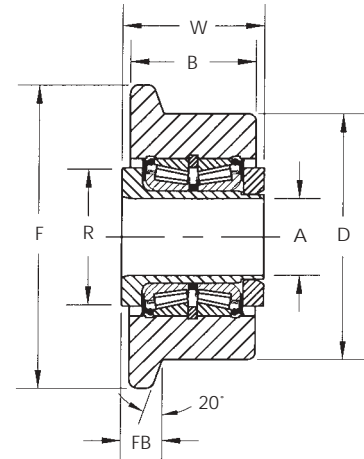

**General Information**

The **Smith-Trax®** Series bearings are designed and manufactured to handle increased axial and radial loads by using **Tapered Roller Bearings** or **Deep Groove Ball Bearings**. These bearings should be used when standard needle roller bearings are not sufficient to handle the thrust load found in certain applications. Consult our Engineering Department for special requirements.

Dimensional Data (mm)

SMITH Bearing® Number	BEARING TYPE TRB-Tapered Roller Bearing	D Roller O.D.	F Flange O.D.	B Roller Width	FB Flange Width	A Bore Diameter +0.00 -0.02	W Overall Width	R Shoulder or End Plate Diameter	Radial Basic Dynamic Rating (N) 500 hrs. 33 rpm.	Dynamic Thrust Load Rating (N) 500 hrs. 33 rpm.	Max Static Capacity (Newtons)
MFYR-62	TRB	62	78	38	14	20	40	32.0	48,400	178,00	20,300
MFYR-76	TRB	76	98	44	13.5	25	46	44.5	63,500	25,700	53,400
MFYR-80	TRB	80	102	44	13.5	25	46	44.5	63,500	25,700	53,400
MFYR-85	TRB	85	107	44	13.5	25	46	44.5	63,500	25,700	53,400
MFYR-90	TRB	90	112	54	13.5	30	56	57.2	78,200	25,600	58,300
MFYR-100	TRB	100	122	54	13.5	30	56	57.2	78,200	25,600	58,300
MFYR-125	TRB	125	148	68	18.2	45	71	82.6	148,100	58,500	144,600
MFYR-150	TRB	150	173	70	18.3	55	73	88.9	159,000	63,000	147,000
MFYR-200	TRB	200	223	76	18.2	70	79	108.0	188,600	77,400	215,000
MFYR-250	TRB	250	273	76	18.2	70	79	108.0	188,600	77,400	215,000

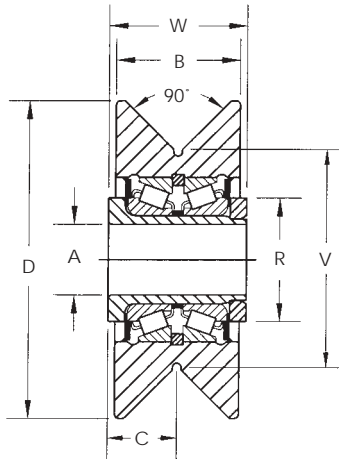

**MVYR**

**V-Groove Yoke Style**

SMITH-TRAX®

**General Information**

The **Smith-Trax®** Series bearings are designed and manufactured to handle increased axial and radial loads by using **Tapered Roller Bearings** or **Deep Groove Ball Bearings**. These bearings should be used when standard needle roller bearings are not sufficient to handle the thrust load found in certain applications. Consult our Engineering Department for special requirements.

Dimensional Data (mm)

SMITH Bearing® Number	BEARING TYPE TRB-Tapered Roller Bearing	D Roller O.D.	B Groove Dia.	A Bore Diameter +0.00 -0.02	W Overall Width	V Point Diameter	C Groove Center	R Shoulder or End Plate Diameter 33 rpm.	Radial Basic Dynamic Rating (N) 500 hrs. 33 rpm.	Dynamic Thrust Load Rating (N) 500 hrs.
MVYR-62	TRB	90	38	20	40	62	22	32.0	48,400	17,800
MVYR-76	TRB	110	44	25	46	76	23	44.5	63,600	25,700
MVYR-100	TRB	140	54	30	56	100	28	57.2	78,200	25,600
MVYR-125	TRB	165	68	45	71	125	36	82.6	148,100	58,500
MVYR-150	TRB	190	70	55	73	150	37	88.9	159,200	63,000
MVYR-200	TRB	240	76	70	79	200	40	108.0	188,600	77,400
MVYR-250	TRB	290	76	70	79	250	40	108.0	188,600	77,400

# INCH SIZES



## Track Roller Bearings

### Plain Track Rollers

SMITH®	McGill	Osborn	PCI
PCR-1-1/2	PCF-1-1/2	PLR-1-1/2	PTR-1.50
PCR-1-3/4	PCF-1-3/4	PLR-1-3/4	PTR-1.75
PCR-2	PCF-2	PLR-2	PTR-2.00
PCR-2-1/4	PCF-2-1/4	PLR-2-1/4	PTR-2.25
PCR-2-3/4	PCF-2-3/4	PLR-2-3/4	PTR-2.75
PCR-3	PCF-3	PLR-3	PTR-3.00
PCR-3-1/4	PCF-3-1/4	PLR-3-1/4	PTR-3.25
PCR-3-1/2	PCF-3-1/2	PLR-3-1/2	PTR-3.50
PCR-4	PCF-4	PLR-4	PTR-4.00
PCR-4-1/2	PCF-4-1/2	PLR-4-1/2	PTR-4.50
PCR-5	PCF-5	PLR-5	PTR-5.00
PCR-6	PCF-6	PLR-6	PTR-6.00
PCR-7	PCF-7	PLR-7	PTR-7.00
PCR-8	PCF-8	PLR-8	PTR-8.00

### Flanged Track Rollers

SMITH®	McGill	Osborn	PCI
FCR-1-1/2	FCF-1-1/2	FLR-1-1/2	FTR-1.50
FCR-1-3/4	FCF-1-3/4	FLR-1-3/4	FTR-1.75
FCR-2	FCF-2	FLR-2	FTR-2.00
FCR-2-1/4	FCF-2-1/4	FLR-2-1/4	FTR-2.25
FCR-2-1/2	FCF-2-1/2	FLR-2-1/2	FTR-2.50
FCR-2-3/4	FCF-2-3/4	FLR-2-3/4	FTR-2.75
FCR-3	FCF-3	FLR-3	FTR-3.00
FCR-3-1/4	FCF-3-1/4	FLR-3-1/4	FTR-3.25
FCR-3-1/2	FCF-3-1/2	FLR-3-1/2	FTR-3.50
FCR-4	FCF-4	FLR-4	FTR-4.00
FCR-4-1/2	FCF-4-1/2	FLR-4-1/2	FTR-4.50
FCR-5	FCF-5	FLR-5	FTR-5.00
FCR-6	FCF-6	FLR-6	FTR-6.00
FCR-7	FCF-7	FLR-7	FTR-7.00
FCR-8	FCF-8	FLR-8	FTR-8.00

### V-Grooved Track Rollers

SMITH	McGill	Osborn	PCI
VCR-3-1/2	VCF-3-1/2	VLR-3-1/2	VTR-3.50
VCR-4-1/2	VCF-4-1/2	VLR-4-1/2	VTR-4.50
VCR-5-1/2	VCF-5-1/2	VLR-5-1/2	VTR-5.50
VCR-6-1/2	VCF-6-1/2	VLR-6-1/2	VTR-6.50
VCR-7-1/2	VCF-7-1/2	VLR-7-1/2	VTR-7.50
VCR-8-1/2	VCF-8-1/2	VLR-8-1/2	VTR-8.50

### U-Grooved Track Rollers

SMITH®	McGill	Osborn	PCI
UCR-2-15/16-1	UCF-2-15/16-1	ULR-2-15/16-A	UTR-2.9375-A
UCR-2-15/16-2	UCF-2-15/16-2	ULR-2-15/16-B	UTR-2.9375-B
UCR-2-15/16-3	UCF-2-15/16-3	ULR-2-15/16-C	UTR-2.9375-C
UCR-2-15/16-4	UCF-2-15/16-4	ULR-2-15/16-D	UTR-2.9375-D
UCR-2-15/16-5	UCF-2-15/16-5	ULR-2-15/16-E	UTR-2.9375-E
UCR-2-15/16-6	UCF-2-15/16-6	ULR-2-15/16-F	UTR-2.9375-F
UCR-2-15/16-7	UCF-2-15/16-7	ULR-2-15/16-G	UTR-2.9375-G
UCR-2-15/16-8	UCF-2-15/16-8	ULR-2-15/16-H	UTR-2.9375-H
UCR-2-15/16-9	UCF-2-15/16-9	ULR-2-15/16-I	UTR-2.9375-I
UCR-2-15/16-10	UCF-2-15/16-10	ULR-2-15/16-J	UTR-2.9375-J

## Yoke Track Roller Bearings

### Plain Yoke Rollers

SMITH®	Osborn	PCI
PYR-3	PLRY-3	PTRY-3.00
PYR-3-1/4	PLRY-3-1/4	PTRY-3.25
PYR-3-1/2	PLRY-3-1/2	PTRY-3.50
PYR-4	PLRY-4	PTRY-4.00
PYR-5	PLRY-5	PTRY-5.00
PYR-6	PLRY-6	PTRY-6.00
PYR-7	PLRY-7	PTRY-7.00
PYR-8	PLRY-8	PTRY-8.00

### Flanged Yoke Rollers

SMITH®	Osborn	PCI
FYR-3	FLRY-3	FTRY-3.00
FYR-3-1/4	FLRY-3-1/4	FTRY-3.25
FYR-3-1/2	FLRY-3-1/2	FTRY-3.50
FYR-4	FLRY-4	FTRY-4.00
FYR-5	FLRY-5	FTRY-5.00
FYR-6	FLRY-6	FTRY-6.00
FYR-7	FLRY-7	FTRY-7.00
FYR-8	FLRY-8	FTRY-8.00

### V-Grooved Yoke Rollers

SMITH®	Osborn	PCI
VYR-4-1/2	VLRY-4-1/2	VTRY-4.50
VYR-5-1/2	VLRY-5-1/2	VTRY-5.50
VYR-6-1/2	VLRY-6-1/2	VTRY-6.50
VYR-7-1/2	VLRY-7-1/2	VTRY-7.50
VYR-8-1/2	VLRY-8-1/2	VTRY-8.50

### Coding for Other Track Rollers

Optional Feature	SMITH®	Osborn	McGILL	PCI
Eccentric Collar	add suffix "E"	add prefix "E"	add prefix "E"	add prefix "E"

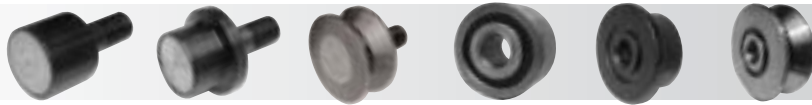

MPCR

MFCR

MVCR

MPYR

MFYR

MVYR

# METRIC SIZES

SMITH-TRAX® Interchange

## Track Roller Bearings

### Plain Track Rollers

SMITH®	Osborn
MPCR-26	HPC-26
MPCR-30	HPC-30
MPCR-32	HPC-32
MPCR-35	HPC-35
MPCR-40	HPC-40
MPCR-47	HPC-47
MPCR-50	HPC-50
MPCR-52	HPC-52
MPCR-62	HPC-62
MPCR-72	HPC-72
MPCR-76	HPC-76
MPCR-80	HPC-80
MPCR-85	HPC-85
MPCR-90	HPC-90
MPCR-100	HPC-100
MPCR-125	HPC-125
MPCR-150	HPC-150
MPCR-200	HPC-200

### V-Grooved Track Rollers

SMITH®	Osborn
MVCR-26	HPV-26
MVCR-32	HPV-32
MVCR-40	HPV-40
MVCR-62	HPV-62
MVCR-76	HPV-76
MVCR-100	HPV-100
MVCR-125	HPV-125

### Flanged Track Rollers

SMITH®	Osborn
MFCR-26	HPJ-26
MFCR-30	HPJ-30
MFCR-32	HPJ-32
MFCR-35	HPJ-35
MFCR-40	HPJ-40
MFCR-47	HPJ-47
MFCR-50	HPJ-50
MFCR-52	HPJ-52
MFCR-62	HPJ-62
MFCR-72	HPJ-72
MFCR-76	HPJ-76
MFCR-80	HPJ-80
MFCR-85	HPJ-85
MFCR-90	HPJ-90
MFCR-100	HPJ-100
MFCR-125	HPJ-125
MFCR-150	HPJ-150
MFCR-200	HPJ-200

## Yoke Track Roller Bearings

### Plain Yoke Rollers

SMITH®	Osborn
MPYR-62	HPCA-62
MPYR-76	HPCA-76
MPYR-80	HPCA-80
MPYR-85	HPCA-85
MPYR-90	HPCA-90
MPYR-100	HPCA-100
MPYR-125	HPCA-125
MPYR-150	HPCA-150
MPYR-200	HPCA-200
MPYR-250	HPCA-250

### V-Grooved Yoke Rollers

SMITH®	Osborn
MVYR-62	HPVA-62
MVYR-76	HPVA-76
MVYR-100	HPVA-100
MVYR-125	HPVA-125
MVYR-150	HPVA-150
MVYR-200	HPVA-200
MVYR-250	HPVA-250

### Flanged Yoke Rollers

SMITH®	Osborn
MFYR-62	HPJA-62
MFYR-76	HPJA-76
MFYR-80	HPJA-80
MFYR-85	HPJA-85
MFYR-90	HPJA-90
MFYR-100	HPJA-100
MFYR-125	HPJA-125
MFYR-150	HPJA-150
MFYR-200	HPJA-200
MFYR-250	HPJA-250

### Coding for Other Track Rollers

Optional Feature	SMITH®	Osborn
Eccentric Collar	add suffix "E"	add prefix "E"

# Ancillary Bearings



---

## IRR Series

Inner Ring Races



---

## GEZ Series

Spherical Plain Bearings  
with Fractured  
Outer Race



---

## YR Series

Yoke Type  
Chain Rollers

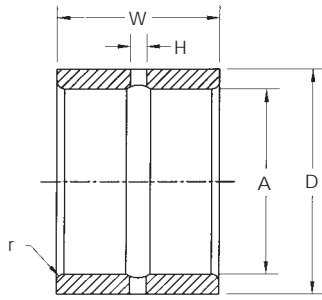

## IRR INNER RING RACES

Dimensional Data (inches)

SMITH Bearing® Number	A Bore Diameter I.D.		D Outside Diameter		W Width +.000 -.005	H Hole Diameter	r Max Fillet for Shaft
	Nominal	Tolerance +0.0000	Nominal	Tolerance +0.0000			
IRR-1/2	.500	-0.0004	.7493	-0.0005	.760	1/8	.040
IRR-9/16	.5625	-0.0004	.7493	-0.0005	.760	1/8	.040
IRR-5/8	.625	-0.0004	.8743	-0.0005	.760	1/8	.040
IRR-11/16	.6875	-0.0004	.8743	-0.0005	.760	1/8	.040
IRR-3/4	.750	-0.0004	.9993	-0.0005	1.010	1/8	.040
IRR-13/16	.8125	-0.0005	.9993	-0.0005	1.010	1/8	.040
IRR-1	1.000	-0.0005	1.2491	-0.0006	1.010	1/8	.040
IRR-1 1/8	1.125	-0.0005	1.3741	-0.0006	1.010	1/8	.040
IRR-1 3/16	1.187	-0.0005	1.4990	-0.0006	1.260	1/8	.060
IRR-1 1/4	1.250	-0.0005	1.4990	-0.0006	1.260	1/8	.060
IRR-1 5/16	1.3125	-0.0005	1.6240	-0.0006	1.260	1/8	.060
IRR-1 3/8	1.375	-0.0005	1.6240	-0.0006	1.260	1/8	.060
IRR-1 7/16	1.4375	-0.0005	1.7490	-0.0006	1.260	1/8	.060
IRR-1 1/2	1.500	-0.0005	1.7490	-0.0005	1.260	1/8	.060
IRR-1 9/16	1.5625	-0.0005	1.8740	-0.0006	1.260	1/8	.060
IRR-1 5/8	1.625	-0.0005	1.9989	-0.0007	1.260	1/8	.060
IRR-1 11/16	1.6875	-0.0005	1.9989	-0.0007	1.260	1/8	.060
IRR-1 3/4	1.750	-0.0005	2.2489	-0.0007	1.760	3/16	.060
IRR-1 7/8	1.875	-0.0005	2.2489	-0.0007	1.760	3/16	.060
IRR-2	2.0000	-0.0005	2.2489	-0.0007	1.760	3/16	.080

### General Information

**SMITH IRR Inner Ring Races** are hardened and ground and are used as bushings or sleeves. Typical material is **52100 Bearing Steel**. They are complete with radial oil holes and an annular lubrication groove. Consult our Engineering Department for special configurations, sizes and materials.

### INTERCHANGE Inner Ring Races

SMITH®	McGill	RBC
IRR-1/2	MI-8-N	IR 7153
IRR-9/16	MI-9-N	IR 7153 C
IRR-5/8	MI-10-N	IR 7173
IRR-11/16	MI-11-N	IR 7173 C
IRR-3/4	MI-12	IR 7194
IRR-13/16	MI-13	IR 7194 C
IRR-1	MI-16-N	IR 7234
IRR-1 1/8	MI-18-N	IR 7254
IRR-1 3/16	MI-19	IR 7275
IRR-1 1/4	MI-20	IR 7275 C
IRR-1 5/16	MI-21	IR 7295
IRR-1 3/8	MI-22-4S	IR 7295 C
IRR-1 7/16	MI-23	IR 7315
IRR-1 1/2	MI-24	IR 7315 C
IRR-1 9/16	MI-25-4S	IR 7335
IRR-1 5/8	MI-26	IR 7355 D
IRR-1 11/16	MI-27	IR 7355
IRR-1 3/4	MI-28	IR 8407
IRR-1 7/8	MI-30	IR 8407 C1
IRR-2	MI-32	IR 8447 C

## YR Yoke Type Chain Rollers

For Shaft Mounting

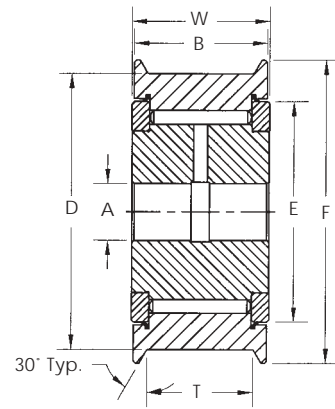

### General Information

**SMITH YR Special Chain Roller** bearings are manufactured for various industrial applications. Typical uses are in forklift style equipment or other chain guide applications which may require a double-flanged outer ring design. The table shown is intended as a guide to indicate basic typical sizes. Consult our Engineering Department for special design needs.

#### Dimensional Data (inches)

SMITH Bearing® Number	D Roller O.D. +.005 -.005	F Flange O.D. +.005 -.005	A Bore Diameter +.0003 -.0003	B Roller Width	W Overall Width	T Track Width	E Minimum Clamping Diameter	Basic Dynamic Capacity (lbs)
YR-2 <sup>1</sup> / <sub>2</sub> -18	2.375	2.75	.7449	1.810	1.873	1.440	1.74	16,000
YR-2 <sup>1</sup> / <sub>2</sub> -28	2.375	2.75	.7685	1.810	1.870	1.440	1.74	16,000
YR-2 <sup>1</sup> / <sub>2</sub> -30	2.375	2.75	.7449	1.810	1.870	1.440	1.74	16,000
YR-6757-2	2.375	2.75	.7449	1.810	1.870	1.440	1.74	16,000
YR-6265-X	2.990	3.38	.7501	1.510	1.564	1.160	2.12	8,750
YR-6636-X	3.150	3.86	.9840	1.850	1.909	1.280	2.25	13,304
YR-6634-X	3.543	4.25	1.3780	1.850	1.909	1.280	2.75	15,432
YR-6757-1	3.745	4.12	.7449	1.810	1.870	1.440	1.74	16,000
YR-4-X-5	3.750	4.13	.7685	1.810	1.870	1.440	3.00	32,000
YR-6635	4.094	3.86	.9840	1.850	1.909	1.280	2.25	13,304

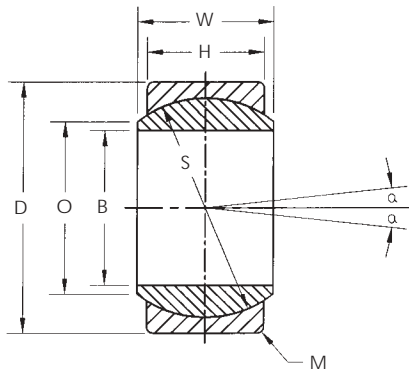

## GEZ

### Spherical Plain Bearings

Metal to Metal  
Fractured Race

#### General Information

**SMITH GEZ** (inch size) and **GE** (metric size) **Plain Spherical Bearings** are assembled units, which consist of a spherical O.D. inner ring and a spherical I.D. outer ring. Both inner and outer rings are phosphate treated and coated with Molybdenum disulphide. Bearings are available in sealed versions. For sealed bearings add suffix "X" (Example: **GEZ12ES-X**).

#### INCH Size Bearings

Dimensional Data (inches)

SMITH Bearing® Number	B Bore Diameter +.0000 -.0005	D Outer Diameter +.0000 -.0005	H Race Width +.000 -.005	W Overall Ball Width +.000 -.005	O Ball Flat Dia. (Ref)	M Race Chamfer (Min)	S Ball Diameter (Ref)	a Max Mis-align Angle	Max Radial Static Load Capacity (lbs)	Approx. Weight (lbs)
GEZ12ES	.5000	.875	.375	.437	.551	.032	.709	6.0	9,330	.044
GEZ15ES	.6250	1.0625	.469	.547	.703	.040	.906	6.0	14,726	.079
GEZ19ES	.7500	1.250	.562	.656	.844	.040	1.083	6.0	21,358	.126
GEZ22ES	.8750	1.4375	.656	.765	.974	.040	1.260	6.0	28,552	.193
GEZ25ES	1.0000	1.625	.750	.875	1.103	.040	1.417	6.0	37,320	.276
GEZ31ES	1.2500	2.000	.937	1.093	1.382	.040	1.772	6.0	58,453	.516
GEZ34ES	1.3750	2.1875	1.031	1.187	1.516	.040	1.929	6.0	69,694	.770
GEZ38ES	1.5000	2.4375	1.125	1.312	1.703	.040	2.165	6.0	84,308	.934
GEZ44ES	1.7500	2.8125	1.312	1.531	1.984	.040	2.520	6.0	114,658	1.430
GEZ50ES	2.0000	3.1875	1.500	1.750	2.266	.048	2.874	6.0	150,629	2.070
GEZ63ES	2.5000	3.9375	1.875	2.187	2.833	.048	3.583	6.0	236,061	4.090
GEZ69ES	2.7500	4.375	2.062	2.406	3.110	.048	3.937	6.0	281,025	5.380
GEZ76ES	3.0000	4.750	2.250	2.625	3.406	.048	4.331	6.0	337,230	6.870

#### METRIC Size Bearings

Dimensional Data (mm)

SMITH Bearing® Number	B Bore Diameter +.000 -.015	D Outer Diameter +.000 -.015	H Race Width +.00 -.15	W Overall Ball Width +.00 -.15	O Ball Flat Dia. (Ref)	M Race Chamfer (Min)	S Ball Diameter (Ref)	a Max Mis-align Angle	Radial Static Load Capacity (Newtons)	Approx. Weight (kilograms)
GE30ES	30	47	18	22	34	0.6	40.7	6	310,000	0.16
GE40ES	40	62	22	28	45	1.0	53.0	7	500,000	0.32
GE45ES	45	68	25	32	50	1.0	60.0	7	640,000	0.46
GE50ES	50	75	28	35	55	1.0	66.0	6	780,000	0.56



# Aerospace Bearings



## Introduction

**Smith Aircraft Bearings** presented in this section have been designed to meet the standards of the aerospace industry and conform to military and other appropriate national standards. When selecting these bearings for your application, it is recommended that you review the engineering data provided, along with any appropriate military or national specifications.

**Smith Bearing®** has been a leader in the design and manufacture of specialized bearings for the unique requirements of jet engines. We have kept pace with the ever increasing demands for anti-friction bearings to operate at higher temperatures. Thrust reversers, afterburners, and divergent nozzles are some of the areas in which **Smith Bearing®** Bearings are currently functioning. Contact our engineering department for recommendations and design assistance.

## Military Qualifications

The products listed meet the military requirements of **Mil-B-3990 (SAE AS 39901)**

**Smith Aircraft Bearings** are marked with the bearing designation including bearing type code. Many of these bearings are supplied pre-lubricated to meet the OEM's special requirements. When ordering, attention must be paid to the original manufacturers parts list requirements so that proper identification can be provided.

## Federal Aviation Administration Parts Manufacturing Approval FAA PMA

Smith manufactures bearings to meet the provisions of the Federal Aviation Regulations (**FAR**) for Parts Manufacturing Approval (**PMA**).

**Smith Bearing®** maintains an active list identifying all of our **FAA PMA** parts and where they are applicable. This list is available upon request.

## Bearing Selection

### YAF (MS21438) & YAT (MS21439)

**YAF** and **YAT** Series Yoke Type bearings have heavy outer ring sections and were designed for application as track rollers where the bearing O.D. is unsupported. These bearings will support heavy rolling or oscillating loads in cam or track roller applications. The **YAF-Series (single row)** needle bearings have a crowned outer race. The **YAT-Series (double row)** needle bearings have large blended outside corner radiuses to help distribute stresses. The outer race is hard-chrome plated and all other exposed surfaces are cadmium plated for corrosion protection. These bearings can be re-lubricated thru the inner ring bore. When mounting, care should be taken to properly support the end plates to eliminate the possibility of bearing separation due to thrust loads. These bearings are dimensionally interchangeable with the corresponding **YAD** and **YAS** Series.

### YAD (MS24465) & YAS (MS24466)

**YAD** and **YAS** Series Yoke Type bearings are dimensionally similar to the **YAF** and **YAT** Series. These bearings were designed for track roller applications where the outer race of the bearing is unsupported. They will handle heavy rolling or oscillating motion. The outer race is hard-chrome plated and all other exposed surfaces are cadmium plated for corrosion protection. The bearing is held together using a swedged ring inserted around the inside of the end washers. These bearings are generally considered for replacement in existing applications. For new applications and current designs use the **YAF** and **YAT** Series.

### YAG (MS24461)

**YAG** Series Yoke Type bearings were designed for applications where the bearing is mounted inside the housing. These bearings handle slow rotating or oscillating motions. All external surfaces except the bore are cadmium plated for corrosion protection. The bearing is held together using a swedged ring inserted around the inside of the end washer.

### HRS (MS21432) & CHRS (MS21447)

**HRS** and **CHRS** Series Stud Type bearings are of non-separable construction and are used in applications involving high-static loads or oscillating motion. The **HRS-Series - straight cylindrical outer race** and the **CHRS-Series - crowned outer race** were designed for airframe usage in flap tracks, canopies, and landing gear. When misalignment is a concern, the **CHRS (crowned)** Series is preferred. The outer races are hard-chrome plated and all other exposed surfaces are cadmium plated for corrosion protection.

# Aerospace Bearings

## Load Ratings

### Aircraft Static Capacity (ASC)

is the maximum load which can be placed on a housing mounted needle roller bearing without seriously brinelling the raceways (approx. 0.0001 inch deep) or deforming the rolling elements.

### Limit Load Rating

is the maximum static load that can be applied without impairing the subsequent function of the bearing.

### Ultimate Static Fracture Load Rating

is a minimum of 1.5 times the Limit Load Rating

## Track Roller Bearings

**YAF, YAT, YAD, and YAS** Series bearings are designed for use as a Track Roller and therefore operate with an unsupported outer race. For this reason deformation of the outer race must be taken into consideration. The dynamic rating method used for track roller bearings is the **Rating as a Track Roller** which equals 1/3 **ASC** (Aircraft Static Capacity). The **Limit Load Rating** for track roller bearings equals 4/9 **ASC** (Aircraft Static Capacity).

**HRS** and **CHRS** Series bearings with integral stud are designed for use as a track roller. For these bearings the **Limit Load Rating** equals 2/3 **ASC** (Aircraft Static Capacity).

## Housing Mounted Bearings:

**YAG** Series bearings must be mounted inside a housing and are not used as a track roller. For these types of bearings the **Ultimate Load Rating** is equal to the **ASC** (Aircraft Static Capacity). The **Limit Load Rating** equals 2/3 **ASC** (Aircraft Static Capacity).

## Temperature

Unsealed aircraft bearings can be operated at temperatures up to 400 °F provided that suitable lubrication is present. Higher temperature exposure will result in loss of capacity. The operating temperature for sealed bearings is limited to 250 °F due to the seal material.

## Stainless Steel

**Smith Bearing®** produces Stainless Steel airframe bearings which are dimensionally interchangeable to our standard line of bearings listed in this section. The special grade of stainless steel used has extremely high strength and corrosion resistance. Material used is per AMS 5925 or AMS 5898 for inner races, outer races, studs and rolls and AMS 5621 for end washers. Consult our engineering department for exact specifications and applications.

## Smith Aircraft & Military Bearings

SMITH Bearing® Model	Description	Military Standard	SAE Standard	ABMA Number	NAS Standard
<b>YAF</b>	Yoke Type • Single Row • Track Roller	MS21438	AS21438	N/A	N/A
<b>YAT</b>	Yoke Type • Double Row • Track Roller	MS21439	AS21439	N/A	N/A
<b>YAD</b>	Yoke Type • Single Row • Track Roller	MS24465	AS24465	NBF	NAS 502
<b>YAS</b>	Yoke Type • Double Row • Track Roller	MS24466	AS24466	NBL	NAS 503
<b>YAG</b>	Yoke Type • Housing Mounted	MS24461	AS24461	NBC	NAS 505
<b>HRS</b>	Stud Type • Track Roller	MS21432	AS21432	HRS	NAS 562
<b>CHRS</b>	Stud Type • Crowned • Track Roller	MS21447	AS21447	CHRS	N/A



## MS21438 (YAF SERIES)

### Single Row

## MS21439 (YAT SERIES)

### Double Row

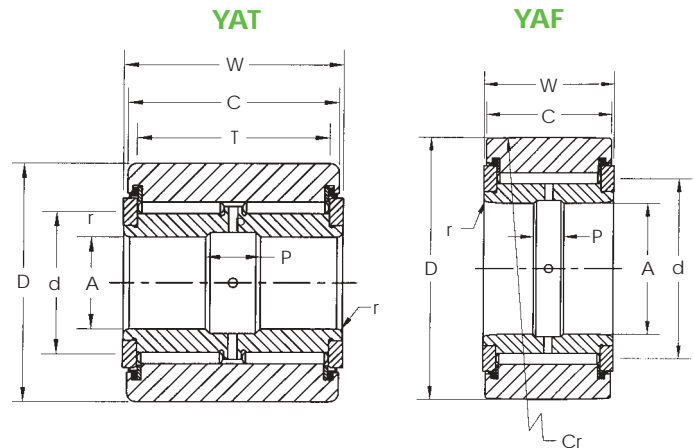

### General Information

The **YAF Single Row** & **YAT Double Row** Series bearings are manufactured in accordance with **MS21438** & **MS21439** standards. The bearings are used in track roller applications with each bearing consisting of an inner race, outer race, needle rollers, end washers & thrust seals. Relubrication holes and grooves are provided. For wear and corrosion protection the outer ring surface is hard-chrome plated. Other exposed surfaces are cadmium or zinc-nickel plated. Inner rings may be black-oxide coated. Consult our Engineering Department for further specific requirements and special designs.

These bearings can be produced from stainless steel grade AMS 5898 & AMS 5925.

SMITH Bearing® Number	Military Number MS	A Bore +.0000 -.0007	D Roller O.D. +.0000 -.0010	W Overall Width +.000 -.005	C Outer Race Width +.000 -.005	T Track Contact Width Min.	Cr Crown radius	d Min. Clamp Dia.	P Lube Groove Width	r Radius	Limit Load Rating (lbf)	Rating As A Track Roller (lbf)	Track Capacity 40HRC (lbf)	Recommended Shaft Diameter				Weight Approx. (lbs)
														Slip Fit		Press Fit		
														Max	Min	Max	Min	
YAF-03	21438-103	0.1900	0.7500	0.312	0.280	-	10.000	0.438	3/32	0.022	1200	900	290	0.1894	0.1889	0.1902	0.1897	0.030
YAF-04	21438-104	0.2500	0.8750	0.375	0.345	-	10.000	0.516	1/8	0.022	1910	1430	575	0.2494	0.2489	0.2502	0.2497	0.051
YAF-06	21438-106	0.3750	1.0625	0.500	0.455	-	10.000	0.672	3/16	0.022	3600	2700	1000	0.3744	0.3739	0.3752	0.3747	0.103
YAF-08	21438-108	0.5000	1.3125	0.625	0.580	-	12.500	0.844	3/16	0.032	5780	4300	1785	0.4994	0.4989	0.5002	0.4997	0.187
YAF-10	21438-110	0.6250	1.5000	0.750	0.705	-	17.500	0.953	1/4	0.032	8530	6400	2600	0.6244	0.6239	0.6252	0.6247	0.279
YAF-12	21438-112	0.7500	1.7500	1.000	0.950	-	25.000	1.109	1/4	0.032	14200	10700	4050	0.7494	0.7489	0.7502	0.7497	0.520
YAF-14	21438-114	0.8750	2.0000	1.125	1.075	-	27.500	1.219	1/4	0.032	19300	14400	5350	0.8744	0.8739	0.8752	0.8747	0.749
YAF-20	21438-120	1.2500	2.5000	1.250	1.200	-	30.000	1.625	3/8	0.032	25300	18900	7100	1.2494	1.2488	1.2503	1.2497	1.160
YAF-24	21438-124	1.5000	3.0000	1.500	1.440	-	60.000	1.984	3/8	0.032	37900	28400	10900	1.4994	1.4988	1.5003	1.4997	2.360
YAF-28	21438-128	1.7500	3.4375	1.500	1.440	-	60.000	2.281	3/8	0.032	44100	33000	12400	1.7494	1.7488	1.7503	1.7497	2.710
YAF-32	21438-132	2.0000	3.8750	1.500	1.440	-	60.000	2.562	3/8	0.032	48900	36700	14000	1.9994	1.9987	2.0003	1.9996	3.420
YAF-36	21438-136	2.2500	4.3125	1.500	1.440	-	60.000	2.859	3/8	0.032	55000	41200	15600	2.2494	2.2487	2.2503	2.2496	4.230
YAF-40	21438-140	2.5000	4.7500	1.500	1.440	-	60.000	3.109	3/8	0.032	59900	44900	17200	2.4994	2.4987	2.5003	2.4996	5.140
YAF-44	21438-144	2.7500	5.0000	1.500	1.440	-	60.000	3.344	3/8	0.032	64800	48600	18100	2.7494	2.7487	2.7503	2.7496	5.490
YAT-06	21439-106	0.3750	1.1250	1.000	0.940	0.750	-	0.672	3/16	0.032	7130	5370	2600	0.3744	0.3739	0.3752	0.3747	0.239
YAT-08	21439-108	0.5000	1.3750	1.250	1.190	1.000	-	0.891	1/4	0.032	12500	9370	4250	0.4994	0.4989	0.5002	0.4997	0.437
YAT-10	21439-110	0.6250	1.6250	1.500	1.440	1.125	-	1.109	3/8	0.032	19900	15000	5650	0.6244	0.6239	0.6252	0.6247	0.728
YAT-12	21439-112	0.7500	1.8750	1.750	1.690	1.375	-	1.281	3/8	0.032	28500	21400	7950	0.7494	0.7489	0.7502	0.7497	1.130

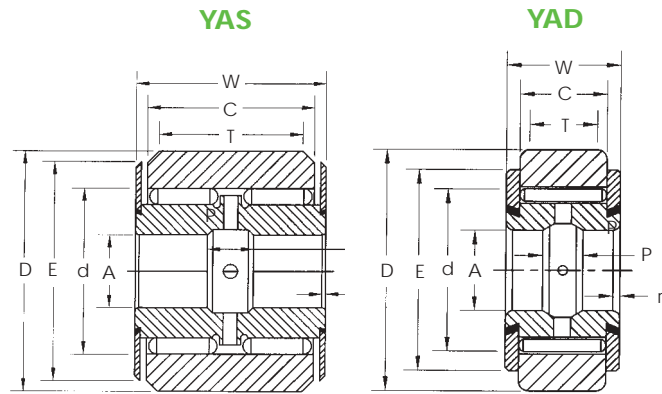

**MS24465 (YAD SERIES)**

Single Row

**MS24466 (YAS SERIES)**

Double Row

**General Information**

The **YAD Single Row** & **YAS Double Row** Series bearings are manufactured in accordance with **MS24465** & **MS24466** standards. The bearings are used in track roller applications with each bearing consisting of an inner race, outer race, needle rollers, end washers & thrust seals. Relubrication holes and grooves are provided. For corrosion protection the outer ring surface is hard chrome plated while all other exposed surfaces are cadmium or zinc-nickel plated. Consult our Engineering Department for further specific requirements and special designs.

Dimensional Data (inches)

SMITH Bearing® Number	Military Number MS	ABMA Number	A Bore +.0000 -.0007	D Roller O.D. +.0000 -.0010	W Overall Width +.000 -.005	C Outer Race Width +.000 -.005	T Track Contact Width Min	E End Ring Dia.	d Min. Clamp Dia.	P Lube Groove Width	r Radius or 45° Chamfer	Limit Load Rating (lbf)	Rating As A Track Roller (lbf)	Track Capacity 40HRC (lbf)	Recommended Shaft Diameter				Weight Approx. (lbs)
															Slip Fit		Press Fit		
															Max	Min	Max	Min	
YAD-03	24465-3	3NBF512YJ	0.1900	0.7500	0.312	0.218	0.125	0.688	0.438	3/32	0.022	1200	900	290	0.1894	0.1889	0.1902	0.1897	0.029
YAD-04	24465-4	4NBF614YJ	0.2500	0.8750	0.375	0.281	0.218	0.750	0.516	1/8	0.022	1910	1430	575	0.2494	0.2489	0.2502	0.2497	0.049
YAD-06	24465-6	6NBF817YJ	0.3750	1.0625	0.500	0.375	0.312	0.938	0.672	3/16	0.022	3600	2700	1000	0.3744	0.3739	0.3752	0.3747	0.980
YAD-08	24465-8	8NBF1012YJ	0.5000	1.3125	0.625	0.500	0.438	1.188	0.844	3/16	0.032	5780	4300	1785	0.4994	0.4989	0.5002	0.4997	0.178
YAD-10	24465-10	10NBF1224YJ	0.6250	1.5000	0.750	0.625	0.562	1.375	0.953	1/4	0.032	8530	6400	2600	0.6244	0.6239	0.6252	0.6247	0.266
YAD-12	24465-12	12NBF1628YJ	0.7500	1.7500	1.000	0.875	0.750	1.625	1.109	1/4	0.032	14200	10700	4050	0.7494	0.7489	0.7502	0.7497	0.495
YAD-14	24465-14	14NBF1832YJ	0.8750	2.0000	1.125	1.000	0.875	1.875	1.219	1/4	0.032	19300	14400	5350	0.8744	0.8739	0.8752	0.8747	0.713
YAD-20	24465-20	20NBF2040YJ	1.2500	2.5000	1.250	1.049	0.938	1.906	1.625	3/8	0.032	25300	18900	7100	1.2494	1.2488	1.2503	1.2497	1.060
YAD-24	24465-24	24NBF2448YJ	1.5000	3.0000	1.500	1.229	1.172	2.875	1.984	3/8	0.032	37900	28400	10900	1.4994	1.4988	1.5003	1.4997	2.070
YAD-28	24465-28	28NBF2455YJ	1.7500	3.4375	1.500	1.229	1.172	3.312	2.281	3/8	0.032	44100	33000	12400	1.7494	1.7488	1.7503	1.7497	2.710
YAD-32	24465-32	32NBF2462YJ	2.0000	3.8750	1.500	1.229	1.172	3.750	2.562	3/8	0.032	48900	36700	14000	1.9994	1.9987	2.0003	1.9996	3.420
YAD-36	24465-36	36NBF2469YJ	2.2500	4.3125	1.500	1.229	1.172	4.188	2.859	3/8	0.032	55000	41200	15600	2.2494	2.2487	2.2503	2.2496	4.230
YAD-40	24465-40	40NBF2476YJ	2.5000	4.7500	1.500	1.229	1.172	4.625	3.109	3/8	0.032	59900	44900	17200	2.4994	2.4987	2.5003	2.4996	5.140
YAD-44	24465-44	44NBF2480YJ	2.7500	5.0000	1.500	1.229	1.172	4.875	3.344	3/8	0.032	64800	48600	18100	2.7494	2.7487	2.7503	2.7496	5.490
YAS-06	24466-6	6NBL1618YJ	0.3750	1.1250	1.000	0.875	0.750	1.000	0.672	3/16	0.032	7130	5370	2600	0.3744	0.3739	0.3752	0.3747	0.228
YAS-08	24466-8	8NBL2022YJ	0.5000	1.3750	1.250	1.125	1.000	1.250	0.891	1/4	0.032	12500	9370	4250	0.4994	0.4989	0.5002	0.4997	0.416
YAS-10	24466-10	10NBL2426YJ	0.6250	1.6250	1.500	1.375	1.125	1.500	1.109	3/8	0.032	19900	15000	5650	0.6244	0.6239	0.6252	0.6247	0.693
YAS-12	24466-12	12NBL2830YJ	0.7500	1.8750	1.750	1.625	1.375	1.750	1.281	3/8	0.032	28500	21400	7950	0.7494	0.7489	0.7502	0.7497	1.180

## MS24461 (YAG SERIES)

### Single Row

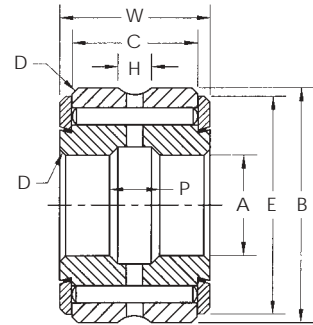

### General Information

The **YAG Series Airframe Bearings** are manufactured in accordance with **MS24461** standards. The O.D. of these bearings are cadmium plated and designed to be mounted inside a housing. Each bearing consists of an inner race, outer race, needle rollers & end washers. Relubrication holes and grooves are provided. For corrosion protection all external surfaces except the bore are cadmium plated. Inner race grooves are omitted from the -3, -4, and -5 sizes due to bolt strength limitations. Consult our Engineering department for further specific requirements and special designs.

Dimensional Data (inches)

SMITH Bearing® Number	Military Number MS	ABMA Number	A Bore +0.000 -0.007	B Roller O.D. +0.000 -0.010	W Overall Width +0.00 -0.05	C Outer Race Width +0.00 -0.05	D Radius or 45° Chamfer	E End Ring Dia.	H Outer Race Groove Width	P Inner Ring Lube Width	d Min Clamp Dia.	Limit Load Rating (lbf)	Aircraft Static Capacity (lbf)	Weight Approx (lbs)
YAG-03-C	24461-3	3NBC511ZP	0.1900	0.6875	0.312	0.218	0.022	0.625	1/16	-	0.438	1800	2700	0.028
YAG-04-C	24461-4	4NBC612ZP	0.2500	0.7500	0.375	0.281	0.022	0.688	11/16	-	0.516	2870	4300	0.040
YAG-05-C	24461-5	5NBC713ZP	0.3125	0.8125	0.437	0.344	0.022	0.750	3/32	-	0.516	4070	6100	0.057
YAG-06	24461-6	6NBC914ZP	0.3750	0.8750	0.562	0.469	0.022	0.812	1/8	3/16	0.641	6330	9500	0.075
YAG-07	24461-7	7NBC1015ZP	0.4375	0.9375	0.625	0.531	0.032	0.875	1/8	3/16	0.703	8000	12000	0.097
YAG-08	24461-8	8NBC1012ZP	0.5000	1.1250	0.750	0.656	0.032	1.031	1/8	3/16	0.844	11600	17400	0.165
YAG-09	24461-9	9NBC1419ZP	0.5625	1.1875	0.875	0.781	0.032	1.094	5/32	3/16	0.891	15000	22500	0.207
YAG-10	24461-10	10NBC1620ZP	0.6250	1.2500	1.000	0.906	0.032	1.156	5/32	1/4	0.953	18900	28300	0.252
YAG-12	24461-12	12NBC1822ZP	0.7500	1.3750	1.125	1.000	0.032	1.281	5/32	1/4	1.078	23900	35800	0.336
YAG-14	24461-14	14NBC2026ZP	0.8750	1.6250	1.250	1.125	0.032	1.500	5/32	3/8	1.250	30500	45800	0.423
YAG-16	24461-16	16NBC2028ZP	1.0000	1.7500	1.250	1.125	0.032	1.625	5/32	3/8	1.375	33900	50900	0.510
YAG-20	24461-20	20NBC2032ZP	1.2500	2.0000	1.250	1.049	0.032	1.906	5/32	3/8	1.625	37900	56800	0.600
YAG-24	24461-24	24NBC2036ZP	1.5000	2.2500	1.250	1.049	0.032	2.156	5/32	3/8	1.875	44200	66300	0.710
YAG-28	24461-28	28NBC2040ZP	1.7500	2.5000	1.250	1.049	0.032	2.406	5/32	3/8	2.125	50500	75700	0.780
YAG-32	24461-32	32NBC2044ZP	2.0000	2.7500	1.250	1.049	0.032	2.656	5/32	3/8	2.375	56800	85200	0.880
YAG-36	24461-36	36NBC2048ZP	2.2500	3.0000	1.250	1.049	0.032	2.906	5/32	3/8	2.625	63100	94600	0.980
YAG-40	24461-40	40NBC2052ZP	2.5000	3.2500	1.250	1.049	0.032	3.156	5/32	3/8	2.875	69400	104100	1.060
YAG-44	24461-44	44NBC2056ZP	2.7500	3.5000	1.250	1.049	0.032	3.406	5/32	3/8	3.125	75700	113500	1.150
YAG-48	24461-48	44NBC2060ZP	3.0000	3.7500	1.250	1.049	0.032	3.656	5/32	3/8	3.375	82000	123000	1.240
YAG-52	24461-52	52NBC2064ZP	3.2500	4.0000	1.250	1.049	0.032	3.906	5/32	3/8	3.641	88300	132500	1.340
YAG-56	24461-56	56NBC2070ZP	3.5000	4.3750	1.250	1.049	0.044	4.219	5/32	3/8	3.969	96700	145100	1.730
YAG-60	24461-60	60NBC2074ZP	3.7500	4.6250	1.250	1.049	0.044	4.469	5/32	3/8	4.219	103000	154500	1.840
YAG-64	24461-64	64NBC2078ZP	4.0000	4.8750	1.250	1.049	0.044	4.719	5/32	3/8	4.469	109000	164000	1.990

**MS24461 (YAG SERIES)**

**Single Row**

(continued)

**"A" Bore Tolerance**

<b>YAG-3 to YAG 52</b>	+0.0000 / -0.0007
<b>YAG-56 to YAG 64</b>	+0.0000 / -0.0008

**"D" Outer Diameter Tolerance**

<b>YAG-3 to YAG 16</b>	+0.0000 / -0.0005
<b>YAG-23 to YAG 36</b>	+0.0000 / -0.0006
<b>YAG-40 to YAG 60</b>	+0.0000 / -0.0008
<b>YAG 64</b>	+0.0000 / -0.0010

Chart continued from previous page

Recommended Shaft Diameter				Recommended Housing Bore Diameter			
Slip Fit		Press Fit		Slip Fit		Press Fit	
Max	Min	Max	Min	Max	Min	Max	Min
0.1894	0.1889	0.1902	0.1897	0.6867	0.6872	0.6874	0.6879
0.2494	0.2489	0.2502	0.2497	0.7492	0.7497	0.7499	0.7504
0.3119	0.3114	0.3127	0.3122	0.8117	0.8122	0.8124	0.8129
0.3744	0.3739	0.3752	0.3747	0.8742	0.8747	0.8749	0.8754
0.4369	0.4364	0.4377	0.4372	0.9367	0.9372	0.9374	0.9379
0.4994	0.4989	0.5002	0.4997	1.1242	1.1247	1.1249	1.1254
0.5619	0.5614	0.5627	0.5622	1.1867	1.1872	1.1874	1.1879
0.6244	0.6239	0.6252	0.6247	1.2492	1.2497	1.2499	1.2504
0.7494	0.7489	0.7502	0.7497	1.3741	1.3747	1.3749	1.3755
0.8744	0.8739	0.8752	0.8747	1.6241	1.6247	1.6249	1.6255
0.9994	0.9989	1.0002	0.9997	1.7491	1.7497	1.7499	1.7505
1.2494	1.2488	1.2503	1.2497	1.9991	1.9997	1.9999	2.0005
1.4994	1.4988	1.5003	1.4997	2.2488	2.2496	2.2499	2.2507
1.7494	1.7488	1.7503	1.7497	2.4988	2.4996	2.4999	2.5007
1.9994	1.9987	2.0003	1.9996	2.7488	2.7496	2.7499	2.7507
2.2494	2.2487	2.2503	2.2496	2.9988	2.9996	2.9999	3.0007
2.4994	2.4987	2.5003	2.4996	3.2485	3.2495	3.2498	3.2508
2.7494	2.7487	2.7503	2.7496	3.4985	3.4995	3.4998	3.5008
2.9994	2.9987	3.0003	2.9996	3.7485	3.7495	3.7498	3.7508
3.2494	3.2486	3.2504	3.2496	3.9985	3.9995	3.9998	4.0008
3.4994	3.4986	3.5004	3.4996	4.3735	4.3745	4.3748	4.3758
3.7494	3.7486	3.7504	3.7496	4.6235	4.6245	4.6248	4.6258
3.9994	3.9986	4.0004	3.9996	4.8735	4.8745	4.8748	4.8758

**MS21432 (HRS SERIES)**

**NAS 562**

**Integral Stud Type**

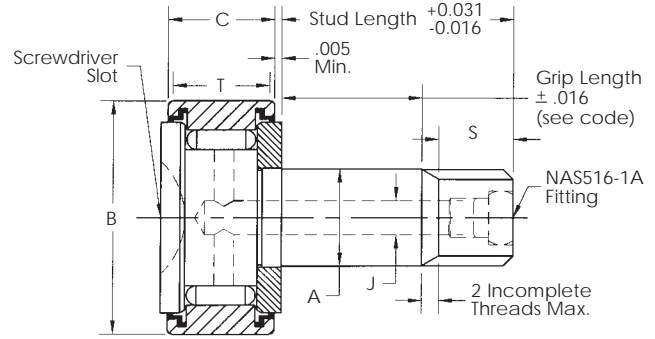

**General Information**

The **HRS Series Integral Stud Type** airframe bearings are manufactured in accordance with **MS21432** standards. The bearings consist of an inner stud, outer race, needle rollers, end washer and if required, seals. Relubrication holes and fittings are optional as shown below. For corrosion protection the outer race is hard-chrome plated while all other exposed surfaces are cadmium or zinc-nickel plated. Consult our Engineering Department for special variations.

**Coding Example:**

**NAS562-8FEE20 AG** = Cam Follower needle bearing 1.125" roller, 0.500" stud, sealed bearing, lubricator in flanged end of stud, 1.2500 grip length 1.672 stud length without cotter pin hole, with Mil-G-23827 grease.

(MS21432)

G = Mil-G-81322 grease; no code = Mil-G-23827 grease.

A = No cotter pin hole (Not required for types T or TEE) Omit for cotter pin hole.

Grip length in .0625 inch increments.

- F = unsealed with lubricator in flanged end of stud.
- T = unsealed with lubricator in threaded end of stud, no cotter pin hole.
- "-" = unsealed without lubricator.
- Bearing FEE = sealed with lubricator in flanged end of stud.
- TEE = sealed with lubricator in threaded end of stud, no cotter pin hole.
- R = sealed bearing without lubrication.

Stud diameter in 0.0625" increments.

Document number.

**Dimensional Data (inches)**

SMITH Bearing® Number	MS Bearing Number	NAS562 Number	A Stud Dia. +.0000 -0.0015	B Roller O.D. +.0010 -0.0005	C Roller Width +.000 -0.005	D Min	S Thread Length	Thread Size	P Cotter Pin Hole Dia.	T Track Contact Length (Min)	J Dia. (Ref)	Track Capacity 40HRC (lbf)	Limit Load Rating (lbf)	Load Rating As A Track Roller (lbf)	Housing Bore Diameter For Stud	
															Max	Min
HRS1	MS21432-3	NAS562-3	0.1900	0.5000	0.281	0.211	0.344	10-32	0.070	0.230	N/A	385	790	395	0.1905	0.1900
HRS2	MS21432-4	NAS562-4	0.2500	0.6875	0.281	0.224	0.344	1/4-28	0.076	0.232	0.076	525	940	470	0.2505	0.2500
HRS3	MS21432-5	NAS562-5	0.3125	0.7500	0.344	0.234	0.359	5/16-24	0.076	0.290	0.076	725	1,660	830	0.3125	0.3120
HRS4	MS21432-6	NAS562-6	0.3750	0.8750	0.469	0.265	0.359	3/8-24	0.106	0.380	0.106	1,100	2,720	1,360	0.3755	0.3750
HRS5	MS21432-7	NAS562-7	0.4375	1.0000	0.531	0.283	0.422	7/16-20	0.106	0.430	0.106	1,425	3,860	1,930	0.4375	0.4370
HRS6	MS21432-8	NAS562-8	0.5000	1.1250	0.656	0.314	0.422	1/2-20	0.106	0.530	0.106	1,975	6,080	3,040	0.5005	0.5000

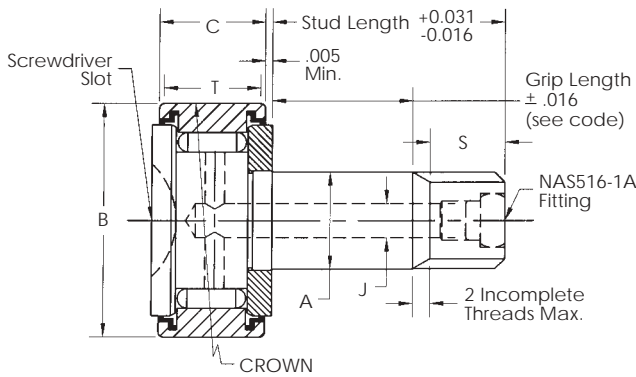

**MS21447 (CHRS SERIES)**

**Integral Stud Type**

**Crowned**

**General Information**

The **CHRS** Series **Integral Stud Type** airframe bearings are manufactured in accordance with **MS21447** standards. The outer races on the CHRS Series are **Crowned**. The bearings consist of an inner stud, outer race, needle rollers, end washer, and if required seals. Relubrication holes and fittings are optional as shown below. For corrosion protection the outer race is hard-chrome plated while all other exposed surfaces are cadmium or zinc-nickel plated. Consult our Engineering Department for special variations.

**Coding Example:**

**MS21447-8F20 AG =** Cam Follower needle bearing 1.1250" roller, stud, sealed with crown radius on the O.D. Lubrication in flanged end of stud. 1.250 grip length 1.672 stud length without cotter pin hole, with Mil-G-23827 grease.

- G = Mil-G-81322 grease; no designator = Mil-G-23827 grease.
- A = No cotter pin hole (Not required for type T) Omit for cotter pin hole.
- Grip length in .0625 inch increments.
- Bearing
  - F = Lubrication in flanged end of stud.
  - T = Lubrication in threaded end of stud. No cotter pin hole.
  - R = Bearing without lubrication.
- Stud diameter in 0.0625" increments.
- Document number.

Dimensional Data (inches)

SMITH Bearing® Number	MS Bearing Number	A Stud Dia.	B Roller O.D.	C Roller Width	D (Min)	S Thread Length	Thread Size	P Cotter Pin Hole Dia.	T Track Contact Length (Min)	J Dia. (Ref)	Track Capacity 40HRC (lbf)	Limit Load Rating (lbf)	Load Rating As A Track Roller (lbf)	Housing Bore Diameter For Stud	
		+ .0000 - .0015	+ .0010 - .0005	+ .000 - .005										Max	Min
CHRS1	MS21447-3	0.1900	0.5000	0.281	0.211	0.344	10-32	0.070	0.230	None	385	790	395	0.1905	0.1900
CHRS2	MS21447-4	0.2500	0.6875	0.281	0.224	0.344	1/4-28	0.076	0.230	0.076	525	940	470	0.2505	0.2500
CHRS3	MS21447-5	0.3125	0.7500	0.344	0.234	0.359	5/16-24	0.076	0.290	0.076	725	1,660	830	0.3125	0.3120
CHRS4	MS21447-6	0.3750	0.8750	0.469	0.265	0.359	3/8-24	0.106	0.380	0.106	1,100	2,720	1,360	0.3755	0.3750
CHRS5	MS21447-7	0.4375	1.0000	0.531	0.283	0.422	7/16-20	0.106	0.430	0.106	1,425	3,860	1,930	0.4375	0.4370
CHRS6	MS21447-8	0.5000	1.1250	0.656	0.314	0.422	1/2-20	0.106	0.530	0.106	1,975	6,080	3,040	0.5005	0.5000



MILITARY Standard Number	TORRINGTON Number	McGILL Number	SMITH® Number
24465-3	3NBF512YJ	3NBF512YJ	YAD-03
24465-4	4NBF614YJ	4NBF614YJ	YAD-04
24465-6	6NBF817YJ	6NBF817YJ	YAD-06
24465-8	8NBF1021YJ	8NBF1021YJ	YAD-08
24465-10	10NBF1224YJ	10NBF1224YJ	YAD-10
24465-12	12NBF1628YJ	12NBF1628YJ	YAD-12
24465-14	14NBF1832YJ	14NBF1832YJ	YAD-14
24465-20	20NBF2040YJ	20NBF2040YJ	YAD-20
24465-24	24NBF2448YJ	24NBF2448YJ	YAD-24
24465-28	28NBF2455YJ	28NBF2455YJ	YAD-28
24465-32	32NBF2462YJ	32NBF2462YJ	YAD-32
24465-36	36NBF2469YJ	36NBF2469YJ	YAD-36
24465-40	40NBF2476YJ	40NBF2476YJ	YAD-40
24465-44	44NBF2480YJ	44NBF2476YJ	YAD-44
24466-6	6NBL1618YJ	6NBL1618YJ	YAS-06
24466-8	8NBL2022YJ	8NBL2022YJ	YAS-08
24466-10	10NBL2426YJ	10NBL2426YJ	YAS-10
24466-12	12NBL2830YJ	12NBL2830YJ	YAS-12
21432-3	HRS-1C	HRS-1C	HRS-1C
21432-4	HRS-2C	HRS-2C	HRS-2C
21432-5	HRS-3C	HRS-3C	HRS-3C
21432-6	HRS-4C	HRS-4C	HRS-4C
21432-7	HRS-5C	HRS-5C	HRS-5C
21432-8	HRS-6C	HRS-6C	HRS-6C
21447-3	CHRS-1C	CHRS-1C	CHRS-1C
21447-4	CHRS-2C	CHRS-2C	CHRS-2C
21447-5	CHRS-3C	CHRS-3C	CHRS-3C
21447-6	CHRS-4C	CHRS-4C	CHRS-4C
21447-7	CHRS-5C	CHRS-5C	CHRS-5C
21447-8	CHRS-6C	CHRS-6C	CHRS-6C
21438-103	ATF-3	3 AFC 512	YAF-03
21438-104	ATF-4	4 AFC 614	YAF-04
21438-106	ATF-6	6 AFC 817	YAF-06
21438-108	AT	8 AFC 1021	YAF-08
21438-110	ATF-10	10 AFC 1224	YAF-10
21438-112	ATF-12	12 AFC 1628	YAF-12

## I N T E R C H A N G E T A B L E S

MILITARY Standard Number	TORRINGTON Number	McGILL Number	SMITH® Number
21438-114	ATF-14	14 AFC 1832	YAF-14
21438-120	ATF-20	20 AFC 2040	YAF-20
21438-124	ATF-24	24 AFC 2448	YAF-24
21438-128	ATF-28	28 AFC 2455	YAF-28
21438-132	ATF-32	32 AFC 2462	YAF-32
21438-136	ATF-36	36 AFC 2469	YAF-36
21438-140	ATF-40	40 AFC 2476	YAF-40
21438-144	ATF-44	44 AFC 2480	YAF-44
21439-106	ATL-6	6 AL 1618	YAT-06
21439-108	ATL-8	8 AL 2022	YAT-08
21439-110	ATL-10	10 AL 2426	YAT-10
21439-112	ATL-12	12 AL 2830	YAT-12
24461-3	3NBC511ZP	3NBC511ZP	YAG-03-C
24461-4	4NBC612ZP	4NBC612ZP	YAG-04-C
24461-5	5NBC713ZP	5NBC713ZP	YAG-05-C
24461-6	6NBC914YZP	6NBC914YZP	YAG-06
24461-7	7NBC1015YZP	7NBC1015YZP	YAG-07
24461-8	8NBC1218YZP	8NBC1218YZP	YAG-08
24461-9	9NBC1419YZP	9NBC1419YZP	YAG-09
24461-10	10NBC1620YZP	10NBC1620YZP	YAG-10
24461-12	12NBC1822YZP	12NBC1822YZP	YAG-12
24461-14	14NBC2026YZP	14NBC2026YZP	YAG-14
24461-16	16NBC2028YZP	16NBC2028YZP	YAG-16
24461-20	20NBC2032YZP	20NBC2032YZP	YAG-20
24461-24	24NBC2036YZP	24NBC2036YZP	YAG-24
24461-28	28NBC2040YZP	28NBC2040YZP	YAG-28
24461-32	32NBC2044YZP	32NBC2044YZP	YAG-32
24461-36	36NBC2048YZP	36NBC2048YZP	YAG-36
24461-40	40NBC2052YZP	40NBC2052YZP	YAG-40
24461-44	44NBC2056YZP	44NBC2056YZP	YAG-44
24461-48	48NBC2060YZP	48NBC2060YZP	YAG-48
24461-52	52NBC2064YZP	52NBC2064YZP	YAG-52
24461-56	56NBC2070YZP	56NBC2070YZP	YAG-56
24461-60	60NBC2074YZP	60NBC2074YZP	YAG-60
24461-64	64NBC2078YZP	64NBC2078YZP	YAG-64

**SEB**

**Slotted Entry Bearings**

**Pre-Swaged, Narrow, Annular**

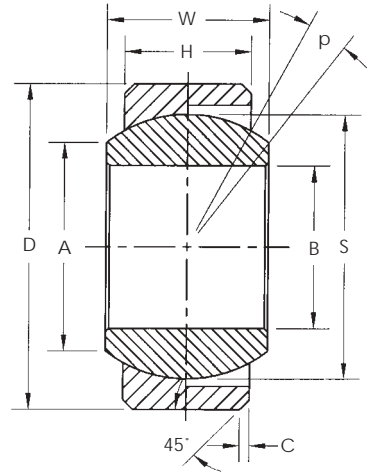

**General Information**

The **SMITH SEB Slotted Entry Bearings** feature a two-piece design which include an inner ball with a spherical race to accommodate misalignment. The outer ring housing has a slotted entry window to allow for fast and easy insertion and removal of the inner ball. Depending on your requirements, the **SMITH SEB Slotted Entry Bearings** can be produced using a wide range of materials. Slotted Entry Bearings are used in various Aerospace applications such as: slats, flap-tracks, landing gear, doors, etc.. Contact our Engineering Department for special design to meet your needs.

SMITH® Bearing Number	B Bore Diameter +.0000 -.0005	D Outside Diameter +.0000 -.0005	C Flanged Diameter +.002 -.002	W Ball Width +.000 -.002	H Race Width +.000 -.002	A Ball Flat Diameter	p' Mis-alignment Angle	S Ball O.D.. (Ref)	Radial Static Limit Load (lbs)	Weight Approx. (lbs)
SEB-4	.2500	.6562	.676	.343	.250	.364	12	.5000	4,880	.02
SEB-5	.3125	.7500	.770	.375	.281	.437	11	.5625	5,309	.03
SEB-6	.3750	.8125	.852	.406	.213	.486	10	.6250	6,435	.04
SEB-7	.4375	.9062	.946	.437	.343	.572	9	.7180	8,069	.06
SEB-8	.5000	1.0000	1.080	.500	.390	.562	9	.8125	11,180	.07
SEB-9	.5625	1.0937	1.174	.562	.437	.624	9	.8750	13,455	.09
SEB-10	.6250	1.1875	1.267	.625	.500	.687	9	.9680	17,166	.11
SEB-12	.7500	1.4375	1.517	.750	.593	.812	9	1.1870	25,680	.17
SEB-14	.8750	1.5625	1.642	.875	.703	.937	9	1.3120	39,610	.22
SEB-16	1.0000	1.7500	1.830	1.000	.797	1.062	9	1.5000	56,290	.28

**SEBF**  
**Slotted Entry Bearings**  
**Flanged**

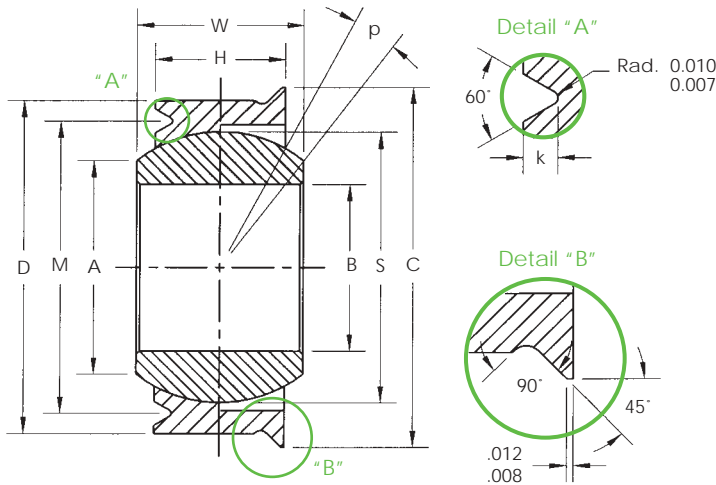

**General Information**

The **SMITH SEBF Slotted Entry Bearings** feature a two-piece design which include an inner ball with a spherical race to accommodate misalignment. The outer ring housing has a slotted entry window to allow for fast and easy insertion and removal of the inner ball. Depending on your requirements, the **SMITH SEBF Slotted Entry Bearings** can be produced using a wide range of materials. Slotted Entry Bearings are used in various Aerospace applications such as: slats, flap-tracks, landing gear, doors, etc.. Contact our Engineering Department for special design to meet your needs.

SMITH Bearing® Number	B Bore Diameter +.0000 -.0005	D Outside Diameter +.0000 -.0005	C Flanged Diameter +.002 -.002	W Ball Width +.000 -.002	H Race Width +.000 -.002	A Ball Flat Diameter	p Mis-alignment Angle	M V-groove Centerline +.002 -.002	K V-groove Depth Size	S Ball O.D.. (Ref)	Radial Static Limit Load (lbs)	Weight Approx. (lbs)
SEBF-4	.2500	.6562	.676	.343	.250	.364	12	.588	.022	.5000	4,880	.02
SEBF-5	.3125	.7500	.770	.375	.281	.437	11	.682	.022	.5625	5,309	.03
SEBF-6	.3750	.8125	.852	.406	.213	.486	10	.714	.032	.6250	6,435	.04
SEBF-7	.4375	.9062	.946	.437	.343	.572	9	.808	.032	.7180	8,069	.06
SEBF-8	.5000	1.0000	1.080	.500	.390	.562	9	.877	.052	.8125	11,180	.07
SEBF-9	.5625	1.0937	1.174	.562	.437	.624	9	.970	.052	.8750	13,455	.09
SEBF-10	.6250	1.1875	1.267	.625	.500	.687	9	1.064	.052	.9680	17,166	.11
SEBF-12	.7500	1.4375	1.517	.750	.593	.812	9	1.314	.052	1.1870	25,680	.17
SEBF-14	.8750	1.5625	1.642	.875	.703	.937	9	1.439	.052	1.3120	39,610	.22
SEBF-16	1.0000	1.7500	1.830	1.000	.797	1.062	9	1.627	.052	1.5000	56,290	.28

“F”

SMITH-ALIGN®

Spherical Bearings

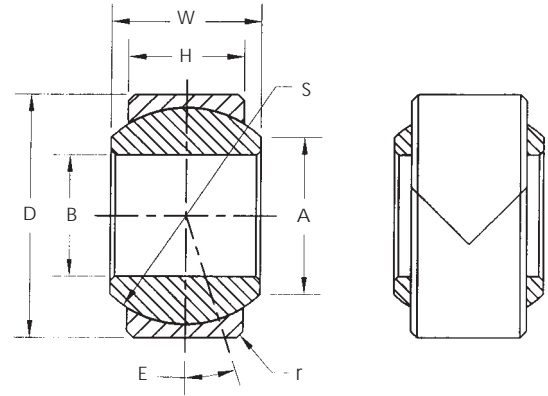

General Information

The “F” Series Smith-Align® Bearings are manufactured for various uses in the Aerospace Industry. The unique design of this bearing is its two-piece outer ring which is “self-retained” around the ball. The two-piece ring is separated by “V” joints. The extreme precision fit of the ball and ring assures complete inner ball and outer ring contact. The bearing can be provided using a variety of materials with either or both components hardened.

The Smith-Align® Bearings are manufactured in various other special series. The table indicates a basic style using SAE 52100 material hardened to RC 58-60. Please consult our Engineering Department for special design needs.

Dimensional Data (inches)

SMITH Bearing® Number	B Bore Diameter +.0000 -.0005	D Outer Diameter +.0000 -.0005	W Overall Ball Width +.000 -.005	H Race Width +.010 -.000	A Flat Diameter +.010 -.005	S Ball Diameter (Ref)	r Chamfer +.015 -.000	E Max. Tilt Angle	Radial Load Capacity (lbs)
F3	.1900	.500	0.359	0.281	0.250	0.437	0.010	18°	10700
F3-1	.1900	.625	0.437	0.322	0.301	0.531	0.010	18°	16000
F4	.2500	.625	0.437	0.322	0.301	0.531	0.010	18°	16000
F5	.3125	.6875	0.437	0.322	0.401	0.593	0.010	18°	17500
F6	.3750	.8125	0.500	0.401	0.472	0.687	0.020	18°	25700
F7	.4375	.9375	0.562	0.437	0.542	0.781	0.020	18°	32100
F8	.5000	1.000	0.625	0.500	0.612	0.875	0.020	18°	41200
F10	.5625	1.125	0.687	0.531	0.726	1.000	0.020	18°	49500
F11	.6250	1.1875	0.750	0.562	0.753	1.062	0.020	18°	53800
F12	.7500	1.375	0.875	0.625	0.892	1.250	0.020	18°	74700
F14	.8750	1.625	0.875	0.750	1.062	1.375	0.030	18°	97700
F16	1.0000	2.125	1.375	1.000	1.275	1.875	0.030	18°	178200
F20	1.2500	2.375	1.500	1.125	1.460	2.093	0.047	18°	223500
F22	1.3750	2.5625	1.687	1.218	1.535	2.261	0.047	18°	263700
F24	1.5000	2.6875	1.687	1.218	1.693	2.390	0.047	18°	277800

**Type P**  
Headless  
Press Fit Style



**Type H**  
with Head  
Press Fit Style



**Type F**  
Fixed  
Renewable



**Type F**  
Slip-Fixed  
Renewable



**Type L**  
Headless  
Liner



**Type HL**  
with Head  
Liner



**Type LS**  
Lockscrew for  
Standard  
Renewable Bushings



**Type TW**  
Lockscrew for  
Thinwall  
Renewable Bushings



# Drill Jig Bushings

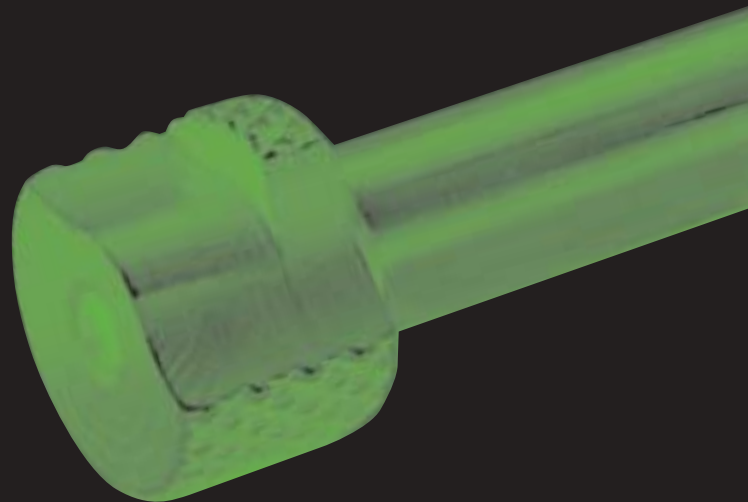
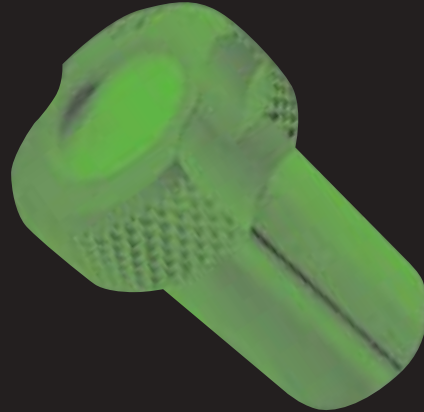
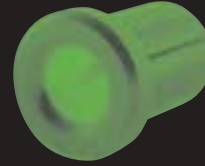



## General Information

### TECHNICAL DATA

#### I.D. Tolerances – ABC ANSI Standard

Standard Drill Sizes	I.D.	Tolerance
#80 to 1/4	Nominal	+ .0001 to + .0004
Over 1/4 to 3/4	Nominal	+ .0001 to + .0005
Over 3/4 to 1 <sup>1</sup> / <sub>2</sub>	Nominal	+ .0002 to + .0006
Over 1 <sup>1</sup> / <sub>2</sub>	Nominal	+ .0003 to + .0007

#### Standard Sizes

Standard sizes in a given I.D. range are sizes listed in the decimal equivalent chart either as a fraction, number or letter size. Any other decimal millimeter size within a given range is considered “**special**” and will be priced accordingly.

#### Special Bushings

When a special unlisted hole size is required, or a special outside diameter or length is required, the bushing becomes a “**special**” and will be priced accordingly.

When the bushing is not standard and has dimensions not according to the catalog, make sure that the length and O.D. are specified as well as the I.D. For Head-Type bushings, specify the head dimensions. Also, where tolerances are to be different from the catalog tolerances, be sure to include the tolerances required.

#### Materials

Drill bushings are manufactured from **C1144 stress-proof steel**, or other high carbon steels known for their long wear and stability. Specialty steels are available upon request.

#### Hardness

**62-64 Rockwell C**

#### Lead

All finish ground press-fit bushings have a concentric ground lead for exact alignment in press-fit starting.

#### Countersink

For drill entry end – a blended radius.

#### Counterbore

Certain bushings are relined in the I.D., depending on the bore-to-length ratio. They can also be supplied without counterbore. This type of bushing will be priced as a “**special**”. To order with **counterbore**, add the prefix letter “**C**” to the symbol.

When using drill bushings with special tools, such as reamers, counterbores, taps, pilots, etc., it would be an advantage if the exact hole size is specified—instead of the tool size. This is important since the tolerance and the clearance of these tools vary according to application.

By processing these “**special**” from semi-finished blanks, prompt service is assured at reasonable prices. All “**special**” bushings will be priced from the factory.

## Ordering Information

### HOW TO ORDER – EXAMPLES

Add Inside Diameter Size to ANSI Symbol

Example:

<b>P-10-5-#77</b>	5/32" Nominal O.D. 5/16" Length with #77 (.0180) Inside Diameter
<b>P-12-4-1/16</b>	3/16" Nominal O.D. 1/4" Length with 1/16" (.0625) Inside Diameter
<b>P-10-5- .0191</b>	5/32" Nominal O.D. 5/16" Length with .0191" Inside Diameter

### Suggestions for Ordering

Complete tolerance and dimensional data on all **ANSI** and **ABC** standard bushings are given in this catalog. See **Fractional Decimal Drill Size Chart** on preceding page for list of standard drill sizes and decimal equivalents. In specifying a drill size, use the number, letter, fractional or decimal size. In specifying decimally, indicate the size in four places;

Example: use .1875, not .187. We would consider .187 as .1870, which would be special.

### Terms

**Net 30 Days,**

F.O.B. Garwood, New Jersey 07027 USA

### Pricing - Prices subject to change without notice

For current price information, call or fax our Sales Department at:

Tel. **908.789.1121** Fax. **908.789.9429**  
www.[accuratebushing.com](http://accuratebushing.com)

### Return of Bushings

Special bushings are non-returnable. Full credit will be given for standard bushings if they are returned **freight prepaid** to the factory within **two weeks** after the date of shipment.

For orders exceeding \$100 U.S., written authorization must be obtained from the factory prior to return shipment.



# Headless Press-Fit

## Type P

Finish Ground & Unground O.D.

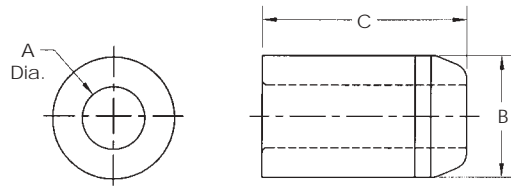

Inside Diameter Range Size (A)	Outside Diameter (B)		Length Inches (C)	ANSI Symbol†	Price Code	
	Finish Ground Size	Unground Size				
#80 - #70 (.0135 - .0280)	.1578 .1575	5/32"	.171	1/4	P-10-4	203
			.169	5/16	P-10-5	209
				3/8	P-10-6	211
				*1/2	P-10-8	214
#69 - 3/64" (.0292 - .0469)	.1578 .1575	5/32"	.171	1/4	P-10-4	190
			.169	5/16	P-10-5	193
				3/8	P-10-6	195
				1/2	P-10-8	199
				*3/4	P-10-12	209
#55 - 1/16" (.0520 - .0625)	.1578 .1575	5/32"	.171	1/4	P-10-4	166
			.169	5/16	P-10-5	170
				3/8	P-10-6	173
				1/2	P-10-8	174
		*3/4	P-10-12	182		
#55 - 1/16" (.0520 - .0625)	.1891 .1888	3/16"	.206	1/4	P-12-4	166
			.203	5/16	P-12-5	170
				3/8	P-12-6	173
				1/2	P-12-8	174
				*5/8	P-12-10	179
		*3/4	P-12-12	182		
#52 - #39 (.0635 - .0995)	.1891 .1888	3/16"	.206	1/4	P-12-4	119
			.203	5/16	P-12-5	125
				3/8	P-12-6	127
				1/2	P-12-8	130
				5/8	P-12-10	132
		*3/4	P-12-12	135		
#80 - #70 (.0135 - .0280)	.2046 .2043	13/64"	.219	1/4	P-13-4	203
			.216	5/16	P-13-5	209
				3/8	P-13-6	211
				*1/2	P-13-8	214
#69 - 3/64" (.0292 - .0469)	.2046 .2043	13/64"	.219	1/4	P-13-4	190
			.216	5/16	P-13-5	193
				3/8	P-13-6	195
				*1/2	P-13-8	199
				*3/4	P-13-12	209
#55 - 1/16" (.0520 - .0625)	.2046 .2043	13/64"	.219	1/4	P-13-4	166
			.216	5/16	P-13-5	170
				3/8	P-13-6	173
				1/2	P-13-8	174
				*3/4	P-13-12	182
				*1	P-13-16	195
#52 - #39 (.0635 - .0995)	.2046 .2043	13/64"	.219	1/4	P-13-4	119
			.216	5/16	P-13-5	125
				3/8	P-13-6	128
				1/2	P-13-8	130
				*3/4	P-13-12	135
				*1	P-13-16	140
		*1 3/8	P-13-22	171		

Inside Diameter Range Size (A)	Outside Diameter (B)		Length Inches (C)	ANSI Symbol†	Price Code	
	Finish Ground Size	Unground Size				
#40 - 9/64" (.0980 - .1406)	.2516 .2513	1/4"	.265	1/4	P-16-4	115
			.260	5/16	P-16-5	118
				3/8	P-16-6	122
				1/2	P-16-8	125
				5/8	P-16-10	128
				*3/4	P-16-12	131
				*1	P-16-16	136
				*1 3/8	P-16-22	169
		*1 1/2	P-16-24	174		
		*1 3/4	P-16-28	179		
1/8" - #10 (.1250 - .1935)	.3141 .3138	5/16"	.327	1/4	P-20-4	110
			.322	5/16	P-20-5	112
				3/8	P-20-6	113
				1/2	P-20-8	114
				5/8	P-20-10	115
				3/4	P-20-12	117
				*1	P-20-16	119
				*1 3/8	P-20-22	140
				*1 1/2	P-20-24	150
		*1 3/4	P-20-28	159		
#10 - #1 (.1935 - .2280) Includes 1/4"	.3766 .3763	3/8"	.390	1/4	P-24-4	105
			.385	5/16	P-24-5	106
				3/8	P-24-6	109
				1/2	P-24-8	110
				5/8	P-24-10	112
				3/4	P-24-12	113
		*1	P-24-16	118		
3/16" - F (.1875 - .2570) Includes .2510	.4078 .4075	13/32"	.421	1/4	P-26-4	105
			.416	5/16	P-26-5	106
				3/8	P-26-6	109
				1/2	P-26-8	110
				3/4	P-26-12	113
				*1	P-26-16	118
				*1 3/8	P-26-22	125
				*1 1/2	P-26-24	131
		*1 3/4	P-26-28	136		
A - L (.2340 - .2900) Includes .2510	.4392 .4389	7/16"	.421	1/4	P-28-4	105
			.416	5/16	P-28-5	106
				3/8	P-28-6	109
				1/2	P-28-8	110
				5/8	P-28-10	112
				3/4	P-28-12	113
		*1	P-28-16	118		
3/16" - O (.1875 - .3160) Includes 3/8"	.5017 .5014	1/2"	.520	1/4	P-32-4	105
			.515	5/16	P-32-5	106
				3/8	P-32-6	109
				1/2	P-32-8	110
				3/4	P-32-12	113
				*1	P-32-16	118
				*1 3/8	P-32-22	125
				*1 1/2	P-32-24	131
				*1 3/4	P-32-28	136
					*2 1/8	P-32-34

† All bushings are finished ground unless the letter "U" appears with the bushings type or the ANSI symbol.

\* Counterbored, leaving correct drill bearing and chip clearance. Metric sizes are available.

Headless Press-Fit

Type P

Finish Ground & Unground O.D.

Chart continued from previous page

Inside Diameter Range Size (A)	Outside Diameter (B)		Length Inches (C)	ANSI Symbol†	Price Code
	Finish Ground Size	Unground Size			
M – 11/32" (.2950 – .3437)	.5642 .5639	9/16"	1/4	P-36-4	110
			5/16	P-36-5	105
			3/8	P-36-6	107
			1/2	P-36-8	107
			5/8	P-36-10	109
			3/4	P-36-12	110
			1	P-36-16	112
5/16" – 7/16" (.3125 – .4375) Includes 1/2"	.6267 .6264	5/8"	1/4	P-40-4	110
			5/16	P-40-5	105
			3/8	P-40-6	107
			1/2	P-40-8	107
			5/8	P-40-10	109
			3/4	P-40-12	110
			1	P-40-16	112
			1 1/4	P-40-20	124
			1 3/8	P-40-22	124
			1 1/2	P-40-24	126
			1 3/4	P-40-28	131
			2 1/8	P-40-30	141
			5/16" – 17/32" (.3125 – .5312) Includes 5/8"	.7518 .7515	3/4"
5/16	P-12-5	106			
3/8	P-12-6	110			
1/2	P-12-8	110			
5/8	P-12-10	112			
3/4	P-13-12	112			
1	P-13-16	114			
1 1/4	P-13-20	125			
1 3/8	P-13-22	125			
1 1/2	P-13-24	128			
1 3/4	P-13-28	132			
2 1/8	P-13-34	142			
2 1/2	P-13-40	193			
1/2" – 21/32" (.5000 – .6562) Includes 3/4"	.8768 .8765	7/8"	5/16	P-56-5	119
			3/8	P-56-6	121
			1/2	P-56-8	115
			5/8	P-56-10	117
			3/4	P-56-12	117
			1	P-56-16	119
			1 1/4	P-56-20	124
			1 3/8	P-56-22	124
			1 1/2	P-56-24	128
			1 3/4	P-56-28	133
			2 1/8	P-56-34	141
2 1/2	P-56-40	151			
1/2" – 49/64" (.5000 – .7656)	1.0018 1.0015	1"	1/2	P-64-8	117
			5/8	P-64-10	117
			3/4	P-64-12	117
			1	P-64-16	120
			1 1/4	P-64-20	124
			1 3/8	P-64-22	124
			1 1/2	P-64-24	130
			1 3/4	P-64-28	135
			2 1/8	P-64-34	141
			2 1/2	P-64-40	151
			3	P-64-48	199

Inside Diameter Range Size (A)	Outside Diameter (B)		Length Inches (C)	ANSI Symbol†	Price Code
	Finish Ground Size	Unground Size			
49/64" – 27/32" (.7656 – .8437)	1.1270 1.1267	1 1/8"	1/2	P-72-8	140
			5/8	P-72-10	136
			3/4	P-72-12	131
			1	P-72-16	140
			1 1/2	P-72-20	148
			1 1/2	P-72-24	152
			1 3/4	P-72-28	159
55/64" – 15/16" (.8594 – .9375)	1.2520 1.2517	1 1/4"	5/8	P-80-10	136
			3/4	P-80-12	131
			1	P-80-16	140
			1 3/8	P-80-20	148
			1 1/2	P-80-24	152
			1 3/4	P-80-28	159
			2	P-80-32	171
5/8" – 11/32" (.6250 – 1.0312)	1.3772 1.3768	1 3/8"	1/2	P-88-8	141
			5/8	P-88-10	138
			3/4	P-88-12	131
			1	P-88-16	141
			1 1/4	P-88-20	149
			1 3/8	P-88-22	149
			1 1/2	P-88-24	153
			1 3/4	P-88-28	161
			2	P-88-32	173
			2 1/8	P-88-34	174
			2 1/2	P-88-40	185
3	P-88-48	222			
1 1/64" – 11/8" (1.0156 – 1.1250)	1.5022 1.5018	1 1/2"	3/4	P-96-12	156
			1	P-96-16	149
			1 1/4	P-96-20	156
			1 1/2	P-96-24	163
			1 3/4	P-96-28	166
			2	P-98-32	182
2 1/4	P-98-36	188			
1" – 125/64" (1.0000 – 1.3906)	1.7523 1.7519	1 3/4"	3/4	P-112-12	156
			1	P-112-16	149
			1 3/8	P-112-22	156
			1 1/2	P-112-24	163
			1 3/4	P-112-28	166
			2 1/8	P-112-34	182
			2 1/2	P-112-40	193
3	P-112-48	240			
1 3/8" – 149/64" (1.3750 – 1.7656)	2.2525 2.2521	2 1/4"	1	P-144-16	167
			1 3/8	P-144-22	178
			1 1/2	P-144-24	183
			1 3/4	P-144-28	187
			2 1/8	P-144-34	204
			2 1/2	P-144-40	216
			3	P-144-48	253

† All bushings are finished ground unless the letter "U" appears with the bushings type or the ANSI symbol.

\* Counterbore, leaving correct drill bearing and chip clearance. Metric sizes are available.

Head Press-Fit

Type H

Finish Ground & Unground O.D.

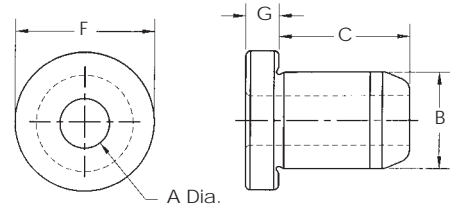

Inside Diameter Range Size (A)	Outside Diameter		Length Inches (C)	ANSI Symbol†	Price Code	
	Finish Ground Size	Unground Size				
#80 - #70 (.0135 - .0280)	.1578 .1575	5/32"	.171	1/4	H-10-4	209
			.169	5/16	H-10-5	211
				*3/8	H-10-6	215
				*1/2	H-10-8	217
#69 - 3/64" (.0292 - .0469)	.1578 .1575	5/32"	.171	1/4	H-10-4	193
			.169	5/16	H-10-5	195
				*3/8	H-10-6	199
				*1/2	H-10-8	202
#55 - 1/16" (.0520 - .0625)	.1578 .1575	5/32"	.171	1/4	H-10-4	171
			.169	5/16	H-10-5	173
				3/8	H-10-6	174
				*1/2	H-10-8	175
#80 - #70 (.0135 - .0280)	.2046 .2043	13/64"	.219	1/4	H-13-4	209
			.216	5/16	H-13-5	211
				*3/8	H-13-6	215
				*1/2	H-13-8	217
#69 - 3/64" (.0292 - .0469)	.2046 .2043	13/64"	.219	1/4	H-13-4	193
			.216	5/16	H-13-5	195
				*3/8	H-13-6	199
				*1/2	H-13-8	202
#55 - 1/16" (.0520 - .0625)	.2046 .2043	13/64"	.219	1/4	H-13-4	171
			.216	5/16	H-13-5	173
				3/8	H-13-6	174
				*1/2	H-13-8	175
#52 - #39 (.0635 - .0995)	.2046 .2043	13/64"	.219	*3/4	H-13-12	186
			.216	*1	H-13-16	200
				1/4	H-13-4	132
				5/16	H-13-5	133
#40 - 9/64" (.0980 - .1406)	.2516 .2513	1/4"	.265	3/8	H-13-6	136
			.260	*1/2	H-13-8	138
				*3/4	H-13-12	147
				*1	H-13-16	165
1/8" - #10 (.1250 - .1935)	.3141 .3138	5/16"	.327	1/4	H-16-4	125
			.322	5/16	H-16-5	128
				3/8	H-16-6	131
				*1/2	H-16-8	132
				*5/8	H-16-10	138
				*3/4	H-16-12	145
				*1	H-16-16	163
				*1 3/8	H-16-22	199
				*1 1/2	H-16-24	208
				1/4	H-20-4	115
				5/16	H-20-5	118
				3/8	H-20-6	121
				1/2	H-20-8	122
				5/8	H-20-10	123
				3/4	H-20-12	124
				*1	H-20-16	133
				*1 3/8	H-20-22	170
				*1 1/2	H-20-24	183

Inside Diameter Range Size (A)	Outside Diameter		Length Inches (C)	ANSI Symbol†	Price Code	
	Finish Ground Size	Unground Size				
#10 - #1 (.1935 - .2280)	.3766 .3763	3/8"	.390	1/4	H-24-4	113
			.385	5/16	H-24-5	115
				3/8	H-24-6	117
				1/2	H-24-8	118
				5/8	H-24-10	120
				3/4	H-24-12	121
3/16" - F (.1875 - .2570)	.4078 .4075	13/32"	.421	*1	H-24-16	130
			.416	*1 3/8	H-26-4	113
				5/16	H-26-5	114
				3/8	H-26-6	117
				1/2	H-26-8	118
				3/4	H-26-12	121
A - L (.2340 - .2900)	.4392 .4389	7/16"	.448	*1	H-26-16	130
			.453	*1 1/2	H-26-24	143
			.448	*1 3/4	H-26-28	150
				1/4	H-28-4	113
				5/16	H-28-5	115
				3/8	H-28-6	117
3/16" - O (.1875 - .3160)	.5017 .5014	1/2"	.520	1/2	H-28-8	118
			.515	5/8	H-28-10	120
				3/4	H-28-12	121
				*1	H-28-16	130
				*1 3/8	H-32-4	113
				5/16	H-32-5	114
M - 11/32" (.2950 - .3437)	.5642 .5639	9/16"	.577	3/8	H-32-6	117
			.582	1/2	H-32-8	118
			.577	5/8	H-32-10	119
				3/4	H-32-12	121
				1	H-32-16	121
				1/4	H-32-4	117
				5/16	P-28-5	113
				3/8	P-28-6	115
				1/2	P-28-8	115
				5/8	P-28-10	117
				3/4	P-28-12	117
				1	P-28-16	121

† All bushings are finished ground unless the letter "U" appears with the bushings type or the ANSI symbol.

\* Counterbore, leaving correct drill bearing and chip clearance. Metric sizes are available.

Head Press-Fit

Type H

Finish Ground & Unground O.D.

Continued from previous page

Inside Diameter Range Size (A)	Outside Diameter		Length Inches (C)	ANSI Symbol†	Price Code	
	Finish Ground Size (B)	Unground Size				
5/16" – 7/16" (.3125 – .4375)	.6267 .6264	5/8"	.645 .640	1/4	H-40-4	117
				5/16	H-40-5	113
				3/8	H-40-6	114
				1/2	H-40-8	114
				5/8	H-40-10	117
				3/4	H-40-12	117
				1	H-40-16	121
				1 3/8	H-40-22	136
				1 1/2	H-40-24	140
				1 3/4	H-40-28	145
				2 1/8	H-40-34	154
5/16" – 17/32" (.3125 – .5312)	.7518 .7515	3/4"	.770 .765	1/4	H-48-4	121
				5/16	H-48-5	115
				3/8	H-48-6	117
				1/2	H-48-8	117
				5/8	H-48-10	119
				3/4	H-48-12	121
				1	H-48-16	125
				1 1/4	H-48-20	138
				1 3/8	H-48-22	138
				1 1/2	H-48-24	141
				1 3/4	H-48-28	146
				2 1/8	H-48-34	156
				1/2" – 21/32" (.5000 – .6562)	.8768 .8765	7/8"
5/8	H-56-10	126				
3/4	H-56-12	127				
1	H-56-16	130				
1 1/4	H-56-20	135				
1 3/8	H-56-22	135				
1 1/2	H-56-24	141				
1 3/4	H-56-28	149				
2 1/8	H-56-34	156				
2 1/2	H-56-40	172				
1/2" – 49/64" (.5000 – .7656)	1.0018 1.0015	1"	1.020 1.015			
				3/4	H-64-12	128
				1	H-64-16	132
				1 3/8	H-64-22	136
				1 1/2	H-64-24	147
				1 3/4	H-64-28	153
				2 1/8	H-64-34	166
				2 1/2	H-64-40	181
3	H-64-48	230				

Inside Diameter Range Size (A)	Outside Diameter		Length Inches (C)	ANSI Symbol†	Price Code	
	Finish Ground Size (B)	Unground Size				
55/64" – 15/16" (.8594 – .9375)	1.2520 1.2517	1 1/4"	1.270 1.265	5/8	H-80-10	153
				3/4	H-80-12	151
				1	H-80-16	158
				1 1/4	H-80-20	166
				1 1/2	H-80-24	174
				1 3/4	H-80-28	181
5/8" – 1-1/32" (.6250 – 1.0312)	1.3772 1.3768	1 3/8"	1.395 1.390	1/2	H-88-8	159
				3/4	H-88-12	152
				1	H-88-16	160
				1 3/8	H-88-22	168
				1 1/2	H-88-24	175
				1 3/4	H-88-28	182
				2 1/8	H-88-34	195
				2 1/2	H-88-40	210
1" – 1-25/64" (1.0000 – 1.3906)	1.7523 1.7519	1 3/4"	1.770 1.765	3/4	H-112-12	187
				1	H-112-16	177
				1 3/8	H-112-22	187
				1 1/2	H-112-24	191
				1 3/4	H-112-28	196
				2 1/8	H-112-34	212
				2 1/2	H-112-40	224
1-3/8" – 1-49/64" (1.3750 – 1.7656)	2.2525 2.2521	2 1/4"	2.270 2.265	3	H-112-48	258
				1	H-144-16	205
				1 3/8	H-144-22	219
				1 1/2	H-144-24	223
				1 3/4	H-144-28	233
				2 1/8	H-144-34	243
				2 1/2	H-144-40	250
				3	H-144-48	268

ANSI HEAD PRESS-FIT  
HEAD DIMENSIONS

Body O.D. (B)	(F)	(G)
5/32"	1/4"	3/32"
13/64"	19/64"	3/32"
1/4"	23/64"	3/32"
5/16"	27/64"	1/8"
3/8"	1/2"	3/32"
13/32"	1/2"	5/32"
7/16"	9/16"	3/32"
1/2"	39/64"	7/32"
9/16"	11/16"	3/32"
5/8"	51/64"	7/32"
3/4"	59/64"	7/32"
7/8"	1-7/64"	1/4"
1"	1-15/64"	5/16"
1-1/4"	1-1/2"	1/4"
1-3/8"	1-39/64"	3/8"
1-3/4"	1-63/64"	3/8"
2-1/4"	2-31/64"	3/8"

† All bushings are finished ground unless the letter "U" appears with the bushings type or the ANSI symbol.

\* Counterbore, leaving correct drill bearing and chip clearance. Metric sizes are available.

## Fixed Renewable Type F Finish Ground O.D.

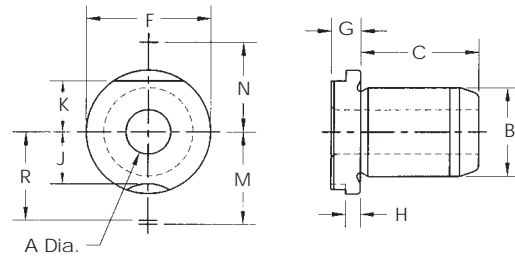

Inside Diameter Range Size (A)	Outside Diameter Finish Ground Size (B)	Length Inches (C)	ANSI Symbol	Price Code	Lock Screw Clamps
#80 - #70 (.0135 - .0280)	3/16"	*1/4	F-12-4	233	LS-0
		*5/16	F-12-5	235	
		*3/8	F-12-6	237	
		*1/2	F-12-8	238	
#69 - 3/64" (.0292 - .0469)	3/16"	1/4	F-12-4	214	LS-0
		*5/16	F-12-5	216	
		*3/8	F-12-6	219	
		*1/2	F-12-8	221	
#55 - 1/16" (.0520 - .0625)	3/16"	1/4	F-12-4	182	LS-0
		*5/16	F-12-5	184	
		*3/8	F-12-6	186	
		*1/2	F-12-8	187	
		*5/8	F-12-10	191	
		*3/4	F-12-12	197	
#52 - #40 (.0635 - .0980)	3/16"	1/4	F-12-4	141	LS-0
		*5/16	F-12-5	142	
		3/8	F-12-6	144	
		*1/2	F-12-8	147	
		*5/8	F-12-10	151	
#39 - 9/64" (.0995 - .1400)	1/4"	1/4	F-16-4	136	TW-2
		5/16	F-16-5	136	
		*3/8	F-16-6	138	
		*1/2	F-16-8	141	
#80 - #70 (.0135 - .0280)	5/16"	*5/16	F-20-5	235	FC-01 LS-1 RC-01
		*3/8	F-20-6	237	
		*1/2	F-20-8	238	
		*3/4	F-20-12	260	
		*1/4	F-20-4	233	
#69 - 3/64" (.0292 - .0469)	5/16"	*5/16	F-20-5	216	LS-1 FC-01 FC-11 RC-01
		*3/8	F-20-6	220	
		*1/2	F-20-8	221	
		*3/4	F-20-12	230	
#55 - 1/16" (.0520 - .0625)	5/16"	*5/16	F-20-5	184	LS-1 FC-01 FC-11 RC-01
		*3/8	F-20-6	186	
		*1/2	F-20-8	187	
#52 - #43 (.0635 - .0890)	5/16"	*3/4	F-20-12	197	LS-1 FC-01 FC-11 RC-01
		5/16	F-20-5	142	
		*3/8	F-20-6	144	
		*1/2	F-20-8	147	
#42 - #31 (.0935 - .1200)	5/16"	*3/4	F-20-12	154	LS-1 FC-01 FC-11 RC-01
		*1	F-20-16	172	
		5/16	F-20-5	136	
		3/8	F-20-6	138	
		*1/2	F-20-8	141	

Inside Diameter Range Size (A)	Outside Diameter Finish Ground Size (B)	Length Inches (C)	ANSI Symbol	Price Code	Lock Screw Clamps
1/8" - #10 (.1250 - .1935)	5/16"	5/16	F-20-5	135	LS-1 FC-01 FC-11 RC-01
		3/8	F-20-6	136	
		1/2	F-20-8	139	
		5/8	F-20-10	143	
		*3/4	F-20-12	148	
		*1	F-20-16	161	
#10 - #1 (.1935 - .2280)	3/8"	*1 3/8	F-20-22	184	TW-2
		1/4	F-24-4	117	
		5/16	F-24-5	120	
		3/8	F-24-6	122	
A - L (.2340 - .2900)	7/16"	1/2	F-24-8	125	TW-2
		5/8	F-24-10	126	
		3/4	F-24-12	128	
		*1	F-24-16	135	
		1/4	F-28-4	117	
#28 - 3/16" (.1405 - .1875)	1/2"	5/16	F-28-5	120	LS-1 FC-01 FC-11 RC-01
		3/8	F-28-6	122	
		1/2	F-28-8	125	
		5/8	F-28-10	126	
		3/4	F-28-12	128	
		*1	F-28-16	135	
#80 - #70 (.0135 - .0280)	1/2"	5/16	F-32-5	120	LS-1 FC-01 FC-11 RC-01
		3/8	F-32-6	122	
		1/2	F-32-8	124	
		3/4	F-32-12	128	
		*1	F-32-16	135	
		*1 1/2	F-32-24	157	
#12 - 11/32" (.1890 - .3437)	1/2"	*1 3/4	F-32-28	164	LS-1 FC-01 FC-11 RC-01
		*3/4	F-32-12	128	
		*1	F-32-16	135	
		*1 1/8	F-32-22	147	
		*1 1/2	F-32-24	150	
M - 11/32" (.2950 - .3437)	9/16"	*1 3/4	F-32-28	155	TW-2
		1/4	F-36-4	117	
		5/16	F-36-5	120	
		3/8	F-36-6	122	
		1/2	F-36-8	125	
		5/8	F-36-10	126	

\* Counterbore, leaving correct drill bearing and chip clearance.  
Metric sizes are available.

Fixed Renewable

Type F

Finish Ground O.D.

Continued from previous page

Inside Diameter Range Size (A)	Outside Diameter Finish Ground Size (B)	Length Inches (C)	ANSI Symbol	Price Code	Lock Screw Clamps
S - 7/16" (.3480 - .4375)	5/8" .6250 .6248	3/8	F-40-6	123	TW-2
		1/2	F-40-8	123	
		5/8	F-40-10	125	
		3/4	F-40-12	126	
		1	F-40-16	130	
		1 1/4	F-40-20	147	
9/32" - 9/16" (.2812 - .5625)	3/4" .7500 .7498	3/8	F-48-6	122	FC-01 FC-11 LS-1 RC-01
		1/2	F-48-8	123	
		3/4	F-48-12	126	
		1	F-48-16	130	
		1 3/8	F-48-22	147	
		1 1/2	F-48-24	151	
		1 3/4	F-48-28	156	
		2 1/8	F-48-40	166	
		*2 1/2	F-48-28	226	
*3	F-48-48	257			
35/64" - 21/32" (.5469 - .6562)	7/8" .8750 .8748	1/2	F-56-8	135	TW-7
		5/8	F-56-10	136	
		3/4	F-56-12	136	
		1	F-56-16	141	
		1 1/4	F-56-22	148	
		1 1/2	F-56-24	152	
15/32" - 25/32" (.4687 - .7812)	1" 1.0000 .9998	1/2	F-64-8	135	FC-02 FC-12 LS-2 RC-02
		3/4	F-64-12	136	
		1	F-64-16	141	
		1 3/8	F-64-22	148	
		1 1/2	F-64-24	153	
		1 3/4	F-64-28	161	
		2 1/8	F-64-34	177	
		2 1/2	F-64-40	234	
		3	F-64-48	259	

Inside Diameter Range Size (A)	Outside Diameter Finish Ground Size (B)	Length Inches (C)	ANSI Symbol	Price Code	Lock Screw Clamps
23/32" - 1 1/16" (.7187 - 1.0625)	1 3/8" 1.3750 1.3747	3/4	F-88-12	164	LS-2 RC-02
		1	F-88-16	175	
		1 3/8	F-88-22	184	
		1 1/2	F-88-24	190	
		1 3/4	F-88-28	198	
		2 1/8	F-88-34	212	
		2 1/2	F-88-40	244	
		3	F-88-48	266	
31/32" - 1 13/32" (.9687 - 1.4062)	1 3/4" 1.7500 1.7497	3/4	F-112-12	202	FC-3 FC-13 LS-3 RC-03
		1	F-112-16	191	
		1 3/8	F-112-22	202	
		1 1/2	F-112-24	210	
		1 3/4	F-112-28	220	
		2 1/8	F-112-34	233	
		2 1/2	F-112-40	252	
		3	F-112-48	266	
1 11/32" - 1 7/8" (1.3437 - 1.8750)	2 1/4" 2.2500 2.2496	3/4	F-144-12	239	FC-3 FC-13 LS-3 RC-03
		1	F-144-16	228	
		1 3/8	F-144-22	239	
		1 1/2	F-144-24	243	
		1 3/4	F-144-28	245	
		2 1/8	F-144-34	256	
		2 1/2	F-144-40	263	
		3	F-144-48	271	

\* Counterbore, leaving correct drill bearing and chip clearance. Metric sizes are available.

DIMENSIONAL DATA ANSI FIXED RENEWABLE HEAD DIMENSIONS									
Body O.D. (B)	(F)	(G)	(H)	(J)	(K)	(M)	(N)	(R)	Lock Screw
3/16"	5/16"	3/16"	3/32"	3/32"				17/64"	LS-0
1/4"	7/16"	1/4"	1/8"	9/64"				23/64"	TW-2
5/16"	35/64"	1/4"	1/8"	11/64"	11/64"	5/8"	11/16"	1/2"	LS-1
3/8"	5/8"	1/4"	1/8"	15/64"				29/64"	TW-2
7/16"	5/8"	1/4"	1/8"	15/64"				29/64"	TW-2
1/2"	51/64"	1/4"	1/8"	19/64"	17/64"	3/4"	25/32"	5/8"	LS-1
9/16"	7/8"	1/4"	1/8"	23/64"				37/64"	TW-2
5/8"	7/8"	1/4"	1/8"	23/64"				37/64"	TW-2
3/4"	1-3/64"	1/4"	1/8"	27/64"	25/64"	7/8"	57/64"	3/4"	LS-1
7/8"	1-1/4"	3/8"	3/16"	31/64"				53/64"	TW-7
1"	1-27/64"	3/8"	3/16"	19/32"	1/2"	1-7/64"	1-9/64"	59/64"	LS-2
1-3/8"	1-51/64"	3/8"	3/16"	25/32"	11/16"	1-19/64"	1-21/64"	1-7/64"	LS-2
1-3/4"	2-19/64"	3/8"	3/16"	1"	7/8"	1-41/64"	1-33/64"	1-25/64"	LS-3
2-1/4"	2-51/64"	3/8"	3/16"	1-1/4"	1-1/8"	1-57/64"	1-49/64"	1-41/64"	LS-3

## Slip-Fixed Renewable Type SF

Finish Ground O.D.

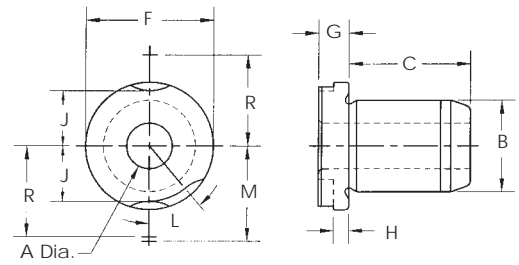

Inside Diameter Range Size (A)	Outside Diameter Finish Ground Size (B)	Length Inches (C)	ANSI Symbol	Price Code	Lock Screw Clamps
#80 - #70 (.0135 - .0280)	3/16"	*1/4	SF-12-4	233	LS-O
		*5/16	SF-12-5	235	
		*3/8	SF-12-6	237	
		*1/2	SF-12-8	238	
		*5/8	SF-12-10	248	
		*3/4	SF-12-12	260	
#69 - 3/64" (.0292 - .0469)	3/16"	1/4	SF-12-4	214	LS-O
		*5/16	SF-12-5	216	
		*3/8	SF-12-6	219	
		*1/2	SF-12-8	221	
		*5/8	SF-12-10	225	
		*3/4	SF-12-12	230	
#55 - 1/16" (.0520 - .0625)	3/16"	1/4	SF-12-4	182	LS-O
		*5/16	SF-12-5	184	
		*3/8	SF-12-6	186	
		*1/2	SF-12-8	187	
		*5/8	SF-12-10	191	
		*3/4	SF-12-12	197	
#52 - #40 (.0635 - .0980)	3/16"	1/4	SF-12-4	141	LS-O
		*5/16	SF-12-5	143	
		*3/8	SF-12-6	144	
		*1/2	SF-12-8	147	
		*5/8	SF-12-10	151	
		*3/4	SF-12-12	154	
#39 - 9/64" (.0995 - .1406)	1/4"	1/4	SF-16-4	136	TW-2
		5/16	SF-16-5	136	
		*3/8	SF-16-6	138	
		*1/2	SF-16-8	141	
		*5/8	SF-16-10	146	
		*3/4	SF-16-12	150	
#80 - #70 (.0135 - .0280)	5/16"	*1/4	SF-20-4	233	LS-1 RC-01 RK-01 RK-11
		*5/16	SF-20-5	235	
		*3/8	SF-20-6	237	
		*1/2	SF-20-8	238	
		*3/4	SF-20-12	260	
		#69 - 3/64" (.0292 - .0469)	5/16"	*5/16	
*3/8	SF-20-6	219			
*1/2	SF-20-8	221			
*3/4	SF-20-12	230			
#55 - 1/16" (.0520 - .0625)	5/16"	*5/16	SF-20-5	184	LS-1 RC-01 RK-01 RK-11
		*3/8	SF-20-6	186	
		*1/2	SF-20-8	187	
		*3/4	SF-20-12	197	
#52 - #43 (.0635 - .0890)	5/16"	5/16	SF-20-5	142	LS-1 RC-01 RK-01 RK-11
		*3/8	SF-20-6	144	
		*1/2	SF-20-8	147	
		*3/4	SF-20-12	154	
		*1	SF-20-16	172	
#42 - #31 (.0935 - .1200)	5/16"	5/16	SF-20-5	136	LS-1 RC-01 RK-01 RK-11
		3/8	SF-20-6	138	
		*1/2	SF-20-8	141	
		*3/4	SF-20-12	150	
		*1	SF-20-16	163	
		*1 3/8	SF-20-22	185	

Inside Diameter Range Size (A)	Outside Diameter Finish Ground Size (B)	Length Inches (C)	ANSI Symbol	Price Code	Lock Screw Clamps
1/8" - #10 (.1250 - .1935)	5/16"	5/16	SF-20-5	135	LS-1 RC-01 RK-01 RK-11
		3/8	SF-20-6	136	
		1/2	SF-20-8	139	
		5/8	SF-20-10	143	
		*3/4	SF-20-12	148	
		*1	SF-20-16	161	
		*1 3/8	SF-20-22	184	
#10 - #1 (.1935 - .2280)	3/8"	1/4	SF-24-4	117	TW-2
		5/16	SF-24-5	120	
		*3/8	SF-24-6	122	
		1/2	SF-24-8	125	
		5/8	SF-24-10	126	
		3/4	SF-24-12	128	
		*1	SF-24-16	135	
A - L (.2340 - .2900)	7/16"	1/4	SF-28-4	117	TW-2
		5/16	SF-28-5	120	
		3/8	SF-28-6	122	
		1/2	SF-28-8	125	
		5/8	SF-28-10	126	
		3/4	SF-28-12	128	
		*1	SF-20-16	135	
#28 - 3/16" (.1405 - .1875)	1/2"	5/16	SF-32-5	126	LS-1 RC-01 RK-01 RK-11
		3/8	SF-32-6	128	
		1/2	SF-32-8	130	
		*3/4	SF-32-12	135	
		*1	SF-32-16	143	
		*1 3/8	SF-32-22	152	
		*1 1/2	SF-32-24	157	
		*1 3/4	SF-32-28	164	
#12 - 11/32" (.1890 - .3437)	1/2"	5/16	SF-32-5	120	LS-1 RC-01 RK-01 RK-11
		3/8	SF-32-6	122	
		1/2	SF-32-8	124	
		3/4	SF-32-12	128	
		*1	SF-32-16	135	
		*1 3/8	SF-32-22	147	
		*1 1/2	SF-32-24	150	
		*1 3/4	SF-32-28	155	
		*2 1/8	SF-32-34	221	
M - 11/32" (.2950 - .3437)	9/16"	1/4	SF-36-4	117	TW-2
		5/16	SF-36-5	120	
		3/8	SF-36-6	122	
		1/2	SF-36-8	125	
		5/8	SF-36-10	126	
		3/4	SF-36-12	128	
		1	SF-36-16	135	

\* Counterbore, leaving correct drill bearing and chip clearance. Metric sizes are available.

**Slip-Fixed Renewable  
Type SF**

**Finish Ground O.D.**

Continued from previous page

Range Size (A)	Finish Ground Size (B)	Length Inches (C)	ANSI Symbol	Price Code	Lock Screw Clamps
S - 7/16" (.3480 - .4375)	5/8" .6250 .6248	3/8	SF-40-6	123	TW-2
		1/2	SF-40-8	123	
		5/8	SF-40-10	125	
		3/4	SF-40-12	126	
		1	SF-40-16	129	
		1 1/4	SF-40-20	147	
9/32" - 9/16" (.2812 - .5625)	3/4" .7500 .7498	3/8	SF-48-6	122	LS-1 RC-01 RK-01 RK-11
		1/2	SF-48-8	123	
		3/4	SF-48-12	126	
		1	SF-48-16	130	
		1 3/8	SF-48-22	147	
		1 1/2	SF-48-24	151	
		1 3/4	SF-48-28	156	
		2 1/8	SF-48-34	166	
		*2 1/2	SF-48-40	226	
		*3	SF-48-48	257	
35/64" - 21/32" (.5469 - .6562)	7/8" .8750 .8748	1/2	SF-56-8	135	TW-7
		5/8	SF-56-10	136	
		3/4	SF-56-12	137	
		1	SF-56-16	141	
		1 3/8	SF-56-20	148	
		1 1/2	SF-56-24	153	
15/32" - 25/32" (.4687 - .7812)	1" 1.0000 .9998	1/2	SF-64-8	135	LS-2 RC-02 RK-2 RK-12
		3/4	SF-64-12	136	
		1	SF-64-16	141	
		1 3/8	SF-64-22	148	
		1 1/2	SF-64-24	152	
		1 3/4	SF-64-28	161	
		2 1/8	SF-64-34	177	
		2 1/2	SF-64-40	234	
		3	SF-64-48	259	

Range Size (A)	Finish Ground Size (B)	Length Inches (C)	ANSI Symbol	Price Code	Lock Screw Clamps
23/32" - 1 1/16" (.7187 - 1.0625)	1 3/8" 1.3750 1.3747	3/4	SF-88-12	164	LS-2 RC-02 RK-2 RK-13
		1	SF-88-16	175	
		1 3/8	SF-88-22	184	
		1 1/2	SF-88-24	190	
		1 3/4	SF-88-28	198	
		2 1/8	SF-88-34	212	
		2 1/2	SF-88-40	244	
		3	SF-88-48	266	
3 1/32" - 1 13/32" (.9687 - 1.4062)	1 3/4" 1.7500 1.7497	3/4	SF-112-12	202	LS-3 RC-03 RK-3 RK-13
		1	SF-112-16	191	
		1 3/8	SF-112-22	202	
		1 1/2	SF-112-24	210	
		1 3/4	SF-112-28	220	
		2 1/8	SF-112-34	233	
		2 1/2	SF-112-40	252	
		3	SF-112-48	267	
1 11/32" - 1 7/8" (1.3437 - 1.8750)	2 1/4" 2.2500 2.2496	3/4	SF-144-12	239	LC-3 RC-03 RK-3 RK-13
		1	SF-144-16	228	
		1 3/8	SF-144-22	239	
		1 1/2	SF-144-24	243	
		1 3/4	SF-144-28	245	
		2 1/8	SF-144-34	256	
		2 1/2	SF-144-40	263	
		3	SF-144-48	271	

\* Counterbore, leaving correct drill bearing and chip clearance. Metric sizes are available.

Body O.D. (B)	DIMENSIONAL DATA ANSI FIXED RENEWABLE HEAD DIMENSIONS								Lock Screw
	(F)	(G)	(H)	(J)	(K)	(M)	(N)	(R)	
3/16"	5/16"	3/16"	3/32"	3/32"	55°			17/64"	LS-0
1/4"	7/16"	1/4"	3/32"	9/64"	30°		11/16"	21/64"	TW-2
5/16"	35/64"	1/4"	1/8"	11/64"	65°	5/8"		1/2"	LS-1
3/8"	5/8"	1/4"	1/8"	15/64"	30°			29/64"	TW-2
7/16"	5/8"	1/4"	1/8"	15/64"	30°			29/64"	TW-2
1/2"	51/64"	1/4"	1/8"	19/64"	65°	3/4"	25/32"	5/8"	LS-1
9/16"	7/8"	1/4"	1/8"	21/64"	30°			37/64"	TW-2
5/8"	7/8"	1/4"	1/8"	21/64"	30°			37/64"	TW-2
3/4"	1-3/64"	1/4"	1/8"	27/64"	50°	7/8"	57/64"	3/4"	LS-1
7/8"	1-1/4"	3/8"	3/16"	33/64"	30°			53/64"	TW-7
1"	1-27/64"	3/8"	3/16"	19/32"	35°	1-7/64"	1-9/64"	59/64"	LS-2
1-3/8"	1-51/64"	3/8"	3/16"	25/32"	30°	1-19/64"	1-21/64"	1-7/64"	LS-2
1-3/4"	2-19/64"	3/8"	3/16"	1"	30°	1-41/64"	1-33/64"	1-25/64"	LS-3
2-1/4"	2-51/64"	3/8"	3/16"	1-1/4"	25°	1-57/64"	1-49/64"	1-41/64"	LS-3



Headless Liner

Type L

Finish Ground & Unground O.D.

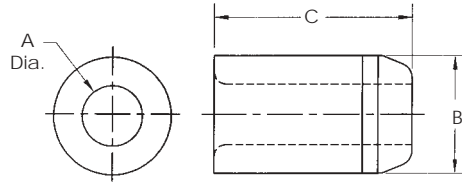

Inside Diameter Range Size (A)	Outside Diameter		Length Inches (C)	ANSI Symbol†	Price Code
	Finish Ground Size	Unground Size			
3/16" (.1876 - .1879)	.3141 .3138	5/16"	.327 .322	1/4 L-20-4 110	
				5/16 L-20-5 112	
				3/8 L-20-6 113	
				1/2 L-20-8 114	
				5/8 L-20-10 115	
				3/4 L-20-12 117	
1/4" (.2501 - .2504)	.4392 .4389	7/16"	.453 .448	1/4 L-28-4 105	
				5/16 L-28-5 106	
				3/8 L-28-6 109	
				1/2 L-28-8 110	
				5/8 L-28-10 112	
5/16" (.3126 - .3129)	.5017 .5014	1/2"	.520 .515	3/4 L-28-12 113	
				1/4 L-32-4 105	
				5/16 L-32-5 106	
				3/8 L-32-6 109	
				1/2 L-32-8 110	
				5/8 L-32-10 112	
				3/4 L-32-12 113	
5/16" (.3126 - .3129)	.5642 .5639	9/16"	.582 .577	1 L-32-16 118	
				1 3/8 L-32-22 125	
				1/4 L-36-4 110	
				5/16 L-36-5 105	
				3/8 L-36-6 107	
				1/2 L-36-8 107	
3/8" (.3751 - .3754)	.6267 .6264	5/8"	.645 .640	5/8 L-36-10 109	
				3/4 L-36-12 110	
				1 L-36-16 112	
				1/4 L-40-4 110	
				5/16 L-40-5 105	
				3/8 L-40-6 107	
7/16" (.4377 - .4380)	.6267 .6264	5/8"	.645 .640	1/2 L-40-8 107	
				5/8 L-40-10 109	
				3/4 L-40-12 110	
				1 L-40-16 112	
				1/4 L-40-4 110	
				5/16 L-40-5 105	
1/2" (.5002 - .5005)	.7518 .7515	3/4"	.770 .765	3/8 L-40-6 107	
				1/2 L-40-8 107	
				5/8 L-40-10 109	
				3/4 L-40-12 110	
				1 L-40-16 112	
				5/16 L-48-5 106	
				3/8 L-48-6 110	
				1/2 L-48-8 110	
9/16" (.5627 - .5630)	.8768 .8765	3/4"	.895 .890	3/4 L-48-12 112	
				1 L-48-16 114	
				1 3/8 L-48-22 125	
				1 1/2 L-48-24 128	
				1 3/4 L-48-28 132	
				2 1/8 L-48-34 142	
				5/16 L-56-5 119	
				3/8 L-56-6 121	
2 1/4" (2.2510 - 2.2515)	2.7526 2.7522	2 3/4"	.895 .890	1/2 L-56-8 115	
				5/8 L-56-10 117	
				3/4 L-56-12 117	
				1 L-56-16 119	
				1 1/4 L-56-20 124	
				5/16 L-56-5 119	

Inside Diameter Range Size (A)	Outside Diameter		Length Inches (C)	ANSI Symbol†	Price Code
	Finish Ground Size	Unground Size			
5/8" (.6252 - .6255)	.8768 .8765	7/8"	.895 .890	5/16 L-56-5 119	
				3/8 L-56-6 121	
				1/2 L-56-8 115	
				5/8 L-56-10 117	
				3/4 L-56-12 117	
				1 L-56-16 119	
3/4" (.7503 - .7506)	1.0018 1.0015	1"	1.020 1.015	1 1/4 L-56-20 124	
				1/2 L-64-8 117	
				3/4 L-64-12 117	
				1 L-64-16 120	
				13/8 L-64-22 124	
				1 1/2 L-64-24 130	
				13/4 L-64-28 135	
7/8" (.8754 - .8757)	1.2520 1.2517	1 1/4"	1.270 1.265	2 1/8 L-64-34 141	
				2 1/2 L-64-40 151	
				3 L-64-48 199	
				1/2 L-80-8 140	
				5/8 L-80-10 136	
				3/4 L-80-12 131	
1" (1.0004 - 1.0007)	1.3772 1.3768	1 3/8"	1.395 1.390	1 L-80-16 140	
				1 1/4 L-80-20 148	
				1 1/2 L-80-24 152	
				1/2 L-88-8 141	
				3/4 L-88-12 131	
				1 L-88-16 141	
1 3/8" (1.3756 - 1.3760)	1.7523 1.7519	1 3/4"	1.770 1.765	13/8 L-88-22 149	
				1 1/2 L-88-24 153	
				13/4 L-88-28 161	
				2 1/8 L-88-34 174	
				2 1/2 L-88-40 185	
				3 L-88-48 222	
1 3/4" (1.7508 - 1.7512)	2.2525 2.2521	2 1/4"	2.270 2.265	3/4 L-112-12 156	
				1 L-112-16 149	
				13/8 L-112-22 156	
				1 1/2 L-112-24 163	
				13/4 L-112-28 166	
				2 1/8 L-112-34 182	
2 1/4" (2.2510 - 2.2515)	2.7526 2.7522	2 3/4"	2.770 2.765	2 1/2 L-112-40 193	
				3 L-112-48 240	
				3/4 L-144-12 178	
				1 L-144-16 167	
				13/8 L-144-22 178	
				1 1/2 L-144-24 183	
2 3/4" (2.2510 - 2.2515)	2.7526 2.7522	2 3/4"	2.770 2.765	13/4 L-144-28 187	
				2 1/8 L-144-34 204	
				2 1/2 L-144-40 216	
				3 L-144-48 253	
				3/4 L-176-12 188	
				1 L-176-16 178	
2 1/2" (2.2510 - 2.2515)	2.7526 2.7522	2 3/4"	2.770 2.765	13/8 L-176-22 189	
				1 1/2 L-176-24 194	
				13/4 L-176-28 201	
				2 1/8 L-176-34 212	
				2 1/2 L-176-40 225	
				3 L-176-48 255	

# DRILL JIG BUSHINGS

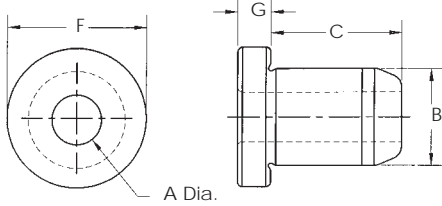

## Head Liner

### Type HL

Finish Ground & Unground O.D.

Inside Diameter Range Size (A)	Outside Diameter		Length Inches (C)	ANSI Symbol†	Price Code
	Finish Ground Size (B)	Unground Size			
5/16" (.3126 - .3129)	.5017 .5014	1/2"	5/16	HL-32-5	114
			3/8	HL-32-6	117
			1/2	HL-32-8	117
			3/4	HL-32-12	121
			1	HL-32-16	135
1/2" (.5002 - .5005)	.7518 .7515	3/4"	1 3/8	HL-32-22	149
			5/16	HL-48-5	115
			3/8	HL-48-6	117
			1/2	HL-48-8	117
			3/4	HL-48-12	121
1" (.7503 - .7506)	1.0018 1.0015	1"	1	HL-48-16	128
			1 3/8	HL-48-22	136
			1 1/2	HL-48-24	141
			1 3/4	HL-48-28	147
			2 1/8	HL-48-34	156
1 3/4" (.7503 - .7506)	1.0018 1.0015	1"	1/2	HL-64-8	126
			3/4	HL-64-12	130
			1	HL-64-16	133
			1 3/8	HL-64-22	136
			1 1/2	HL-64-24	143
1" (1.0004 - 1.0007)	1.3772 1.3768	1 3/8"	1 3/4	HL-64-28	151
			2 1/8	HL-64-34	161
			2 1/2	HL-64-40	177
			3	HL-64-48	228
			1/2	HL-88-8	144
1 3/8" (1.3756 - 1.3760)	1.7523 1.7519	1 3/4"	3/4	HL-88-12	136
			1	HL-88-16	144
			1 3/8	HL-88-22	150
			1 1/2	HL-88-24	153
			1 3/4	HL-88-28	161
1 3/4" (2.2510 - 2.2515)	2.2525 2.2521	2 1/4"	2 1/8	HL-88-34	171
			2 1/2	HL-88-40	185
			3	HL-88-48	246
			3/4	HL-112-12	158
			1	HL-112-16	163
2 1/4" (2.2510 - 2.2515)	2.270 2.265	2 1/4"	1 3/8	HL-112-22	170
			1 1/2	HL-112-24	176
			1 3/4	HL-112-28	182
			2 1/8	HL-112-34	195
			2 1/2	HL-112-40	210
2 1/4" (2.2510 - 2.2515)	2.2525 2.2521	2 1/4"	3	HL-112-48	261
			3/4	HL-144-12	191
			1	HL-144-16	184
			1 3/8	HL-144-22	192
			1 1/2	HL-144-24	198
2 1/4" (2.2510 - 2.2515)	2.7526 2.7522	2 3/4"	1 3/4	HL-144-28	205
			2 1/8	HL-144-34	218
			2 1/2	HL-144-40	231
			3	HL-144-48	264
			3/4	HL-176-12	216
2 1/4" (2.2510 - 2.2515)	2.7526 2.7522	2 3/4"	1	HL-176-16	203
			1 3/8	HL-176-22	218
			1 1/2	HL-176-24	222
			1 3/4	HL-176-28	229
			2 1/8	HL-176-34	241
2 1/4" (2.2510 - 2.2515)	2.7526 2.7522	2 3/4"	2 1/2	HL-176-40	249
			3	HL-176-48	270

### ANSI HEAD LINER HEAD DIMENSIONS

Body O.D. (B)	(F)	(G)
1/2"	5/8"	3/32"
3/4"	7/8"	3/32"
1	1-1/8"	1/8"
1-3/8"	1-1/2"	1/8"
1-3/4"	1-7/8"	3/16"
2-1/4"	2-3/8"	3/16"
2-3/4"	2-7/8"	3/16"

### I.D. TOLERANCES ABS & ANSI STANDARD

Standard Drill Sizes	I.D.	Tolerance
3/16" - 3/8"	Nominal	+ .0001" - + .0004"
7/16" - 5/8"	Nominal	+ .0002" - + .0005"
3/4"	Nominal	+ .0003" - + .0006"
7/8" - 1"	Nominal	+ .0004" - + .0007"
1-3/8"	Nominal	+ .0006" - + .0010"
1-3/4"	Nominal	+ .0008" - + .0012"
2-1/4"	Nominal	+ .0010" - + .0015"

† All bushings are finished ground unless the letter "U" appears with the bushings type or the ANSI symbol.

MISCELLANEOUS HARDWARE

Lock Screws for  
ANSI Carbide and  
Extended Renewable  
Bushings



Type LS Series

Standard Part No.	(A)	(B)	(C)	(E)	(F)	Thread
LS-0	7/16"	3/16"	5/16"	.100	.097"	8-32
LS-1	5/8"	3/8"	5/8"	1/4"	.035"	5/16" - 18
LS-2	7/8"	3/8"	5/8"	3/8"	.197"	5/16" - 18
LS-3	1"	7/16"	3/4"	3/8"	.197"	3/8 - 16
LS-4	1-1/16"	7/16"	3/4"	7/16"	.228"	3/8 - 16
LS-5	1-1/8"	7/16"	3/4"	1/2"	.260"	3/8 - 16

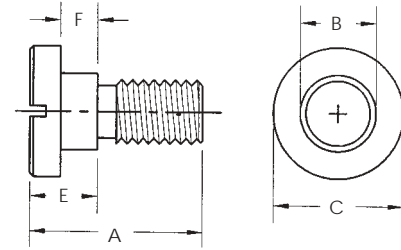

Lock Screws for  
Thin Wall Renewable  
Bushings

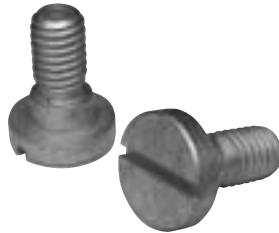

Type TW Series

Slotted Part No.	(G)	(H)	(I)	(J)	(L)	Thread
TW-1	3/16"	3/32"	3/16"	5/16"	1/4"	8-32
TW-2	1/4"	1/8"	1/4"	3/8"	1/4"	10-32
TW-3	3/8"	3/16"	1/4"	7/16"	5/16"	10-32
TW-4	1/2"	1/4"	3/8"	9/16"	3/8"	5/16 - 18
TW-5	5/8"	5/16"	3/8"	5/8"	3/8"	5/16 - 18
TW-7	3/8"	3/16"	3/8"	5/8"	3/8"	5/16 - 18

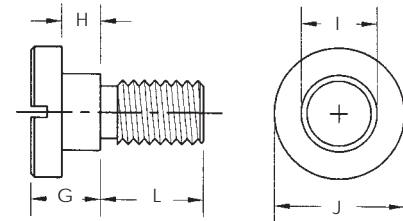

Custom Bushings and Accessories Manufactured to Your Requirements

Miscellaneous Hardware

- Round Clamps – for "F" Type Renewable Bushings
- Extended Range Bushings – Finish Ground and Unground O.D.
- Oil Groove – Applications that require lubrication
- Thin Wall Bushings

SMITH BEARING® is a registered trademark of ABC • Accurate Bushing Company

## CAM FOLLOWERS (Needle Roller Yoke Type & Stud Type)

INCH Sizes - Yoke Type & Stud Type • Unsealed .....	94
INCH Sizes - Yoke Type & Stud Type • Sealed .....	95
Stainless Steel .....	96
Non-Metallic Bushing .....	97
METRIC Sizes - Yoke Type & Stud Type .....	98
NUKR Metric Yoke • Double Row • Heavy Roller • Full Complement	99
MUTD Metric Stud • Double Row • Heavy Roller • Full Complement	99

## SMITH-TRAX®

Inch Smith®-Trax .....	100
Metric Smith®-Trax .....	101

## AEROSPACE Bearings

<b>MS21438/YAF</b>	Airframe Track Rollers Needle Bearings - Single Row
<b>MS21439/YAT</b>	Airframe Track Rollers Needle Bearings - Double Row
<b>MS24465/YAD</b>	Airframe Track Rollers Needle Bearings - Single Row
<b>MS24466/YAS</b>	Airframe Track Rollers Needle Bearings - Double Row
<b>MS24461/YAG</b>	Bearings, Roller, Needle, Heavy Duty - Single Row
<b>MS21432/HRS</b>	Airframe Integral Stud
<b>MS21447/CHRS</b>	Airframe Integral Stud - Crowned

102-103

INTERCHANGE TABLES

Unsealed Cam Followers

Regular Stud • Unsealed

SMITH®	McGill	RBC	Torrington
CR - 1/2-A	CF - 1/2-N	---	CR - 8
CR - 1/2	CF - 1/2	S - 16	CR - 8-1
CR - 9/16	CF - 9/16	S - 18	---
CR - 5/8-A	CF - 5/8-N	---	CR - 10
CR - 5/8	CF - 5/8	S - 20	CR - 10-1
CR - 11/16	CF - 11/16	S - 22	---
CR - 3/4	CF - 3/4	S - 24	CR - 12
CR - 7/8	CF - 7/8	S - 28	CR - 14
CR - 1	CF - 1	S - 32	CR - 16
CR - 1 1/8	CF - 1 1/8	S - 36	CR - 18
CR - 1 1/4	CF - 1 1/4	S - 40	CR - 20
CR - 1 3/8	CF - 1 3/8	S - 44	CR - 22
CR - 1 1/2	CF - 1 1/2	S - 48	CR - 24
CR - 1 5/8	CF - 1 5/8	S - 52	CR - 26
CR - 1 3/4	CF - 1 3/4	S - 56	CR - 28
CR - 1 7/8	CF - 1 7/8	S - 60	CR - 30
CR - 2	CF - 2	S - 64	CR - 32
CR - 2 1/4	CF - 2 1/4	S - 72	CR - 36
CR - 2 1/2	CF - 2 1/2	S - 80	CR - 40
CR - 2 3/4	CF - 2 3/4	S - 88	CR - 44
CR - 3	CF - 3	S - 96	CR - 48
CR - 3 1/4	CF - 3 1/4	S - 104	CR - 52
CR - 3 1/2	CF - 3 1/2	S - 112	CR - 56
CR - 4	CF - 4	S - 128	CR - 64
CR - 5	CF - 5	S - 160	CR - 80
CR - 6	CF - 6	S - 192	CR - 96

Heavy Stud • Unsealed

SMITH®	McGill	RBC
HR - 1/2	CFH - 1/2	H-16
HR - 5/8	CFH - 5/8	H-20
HR - 3/4	CFH - 3/4	H-24
HR - 7/8	CFH - 7/8	H-28
HR - 1	CFH - 1	H-32
HR - 1 1/8	CFH - 1 1/8	H-36
HR - 1 1/4	CFH - 1 1/4	H-40
HR - 1 3/8	CFH - 1 3/8	H-44
HR - 1 1/2	CFH - 1 1/2	H-48
HR - 1 5/8	CFH - 1 5/8	H-52
HR - 1 3/4	CFH - 1 3/4	H-56
HR - 1 7/8	CFH - 1 7/8	H-60
HR - 2	CFH - 2	H-64
HR - 2 1/4	CFH - 2 1/4	H-72
HR - 2 1/2	CFH - 2 1/2	H-80
HR - 2 3/4	CFH - 2 3/4	H-88
HR - 3	CFH - 3	H-96
HR - 3 1/4	CFH - 3 1/4	H-104
HR - 3 1/2	CFH - 3 1/2	H-112
HR - 4	CFH - 4	H-128

Yoke Roller • Unsealed

SMITH®	McGill	RBC	Torrington
YR - 3/4	CYR - 3/4	Y-24	YCR - 12
YR - 7/8	CYR - 7/8	Y-28	YCR - 14
YR - 1	CYR - 1	Y-32	YCR - 16
YR - 1 1/8	CYR - 1 1/8	Y-36	YCR - 18
YR - 1 1/4	CYR - 1 1/4	Y-40	YCR - 20
YR - 1 3/8	CYR - 1 3/8	Y-44	YCR - 22
YR - 1 1/2	CYR - 1 1/2	Y-48	YCR - 24
YR - 1 5/8	CYR - 1 5/8	Y-52	YCR - 26
YR - 1 3/4	CYR - 1 3/4	Y-56	YCR - 28
YR - 1 7/8	CYR - 1 7/8	Y-60	YCR - 30
YR - 2	CYR - 2	Y-64	YCR - 32
YR - 2 1/4	CYR - 2 1/4	Y-72	YCR - 36
YR - 2 1/2	CYR - 2 1/2	Y-80	YCR - 40
YR - 2 3/4	CYR - 2 3/4	Y-88	YCR - 44
YR - 3	CYR - 3	Y-96	YCR - 48
YR - 3 1/4	CYR - 3 1/4	Y-104	YCR - 52
YR - 3 1/2	CYR - 3 1/2	Y-112	YCR - 56
YR - 4	CYR - 4	Y-128	YCR - 64
YR - 5	CYR - 5	Y-160	YCR - 80
YR - 6	CYR - 6	Y-192	YCR - 96

Optional Features	SMITH®	McGill	RBC	Torrington
Hex-Drive	Add Suffix "B"	Add Suffix "B"	Add Suffix "W"	Add Prefix "B"
Eccentric	Add Suffix "E"	Add Suffix "E"	Add Suffix "X"	Add Prefix "E"
Crowned O.D.	Add Suffix "C"	Add Prefix "C"	Add Prefix "C"	Add Prefix "C"
Thrust Seal	Add Suffix "L"	-	Replace "S" with "L"	-

INTERCHANGE TABLES

Sealed Cam Followers

Regular Stud • Sealed

SMITH®	McGill	RBC	Torrington
CR - 1/2-AX	CF - 1/2-N-S	---	CRS - 8
CR - 1/2-X	CF - 1/2-S	S - 16 -S	CRS - 8-1
CR - 9/16-X	CF - 9/16-S	S - 18 -S	---
CR - 5/8-AX	CF - 5/8-N-S	---	CRS - 10
CR - 5/8-X	CF - 5/8-S	S - 20 -S	CRS - 10-1
CR - 11/16-X	CF - 11/16-S	S - 22 -S	---
CR - 3/4-X	CF - 3/4-S	S - 24 -S	CRS - 12
CR - 7/8-X	CF - 7/8-S	S - 28 -S	CRS - 14
CR - 1-X	CF - 1-S	S - 32 -S	CRS - 16
CR - 1 1/8-X	CF - 1 1/8-S	S - 36 -S	CRS - 18
CR - 1 1/4-X	CF - 1 1/4-S	S - 40 -S	CRS - 20
CR - 1 3/8-X	CF - 1 3/8-S	S - 44 -S	CRS - 22
CR - 1 1/2-X	CF - 1 1/2-S	S - 48 -S	CRS - 24
CR - 1 5/8-X	CF - 1 5/8-S	S - 52 -S	CRS - 26
CR - 1 3/4-X	CF - 1 3/4-S	S - 56 -S	CRS - 28
CR - 1 7/8-X	CF - 1 7/8-S	S - 60 -S	CRS - 30
CR - 2-X	CF - 2-S	S - 64 -S	CRS - 32
CR - 2 1/4-X	CF - 2 1/4-S	S - 72 -S	CRS - 36
CR - 2 1/2-X	CF - 2 1/2-S	S - 80 -S	CRS - 40
CR - 2 3/4-X	CF - 2 3/4-S	S - 88 -S	CRS - 44
CR - 3-X	CF - 3-S	S - 96 -S	CRS - 48
CR - 3 1/4-X	CF - 3 1/4-S	S - 104 -S	CRS - 52
CR - 3 1/2-X	CF - 3 1/2-S	S - 112 -S	CRS - 56
CR - 4-X	CF - 4-S	S - 128 -S	CRS - 64
CR - 5-X	CF - 5-S	S - 160 -S	CRS - 80
CR - 6-X	CF - 6-S	S - 192 -S	CRS - 96

Heavy Stud • Sealed

SMITH®	McGill	RBC
HR - 1/2-X	CFH - 1/2-S	H-16 -S
HR - 5/8-X	CFH - 5/8-S	H-20 -S
HR - 3/4-X	CFH - 3/4-S	H-24 -S
HR - 7/8-X	CFH - 7/8-S	H-28 -S
HR - 1-X	CFH - 1-S	H-32 -S
HR - 1 1/8-X	CFH - 1 1/8-S	H-36 -S
HR - 1 1/4-X	CFH - 1 1/4-S	H-40 -S
HR - 1 3/8-X	CFH - 1 3/8-S	H-44 -S
HR - 1 1/2-X	CFH - 1 1/2-S	H-48 -S
HR - 1 5/8-X	CFH - 1 5/8-S	H-52 -S
HR - 1 3/4-X	CFH - 1 3/4-S	H-56 -S
HR - 1 7/8-X	CFH - 1 7/8-S	H-60 -S
HR - 2-X	CFH - 2-S	H-64 -S
HR - 2 1/4-X	CFH - 2 1/4-S	H-72 -S
HR - 2 1/2-X	CFH - 2 1/2-S	H-80 -S
HR - 2 3/4-X	CFH - 2 3/4-S	H-88 -S
HR - 3-X	CFH - 3-S	H-96 -S
HR - 3 1/4-X	CFH - 3 1/4-S	H-104 -S
HR - 3 1/2-X	CFH - 3 1/2-S	H-112 -S
HR - 4-X	CFH - 4-S	H-128 -S

Yoke Roller • Sealed

SMITH®	McGill	RBC	Torrington
YR - 3/4-X	CYR - 3/4-S	Y-24 -S	YCRS - 12
YR - 7/8-X	CYR - 7/8-S	Y-28 -S	YCRS - 14
YR - 1-X	CYR - 1-S	Y-32 -S	YCRS - 16
YR - 1 1/8-X	CYR - 1 1/8-S	Y-36 -S	YCRS - 18
YR - 1 1/4-X	CYR - 1 1/4-S	Y-40 -S	YCRS - 20
YR - 1 3/8-X	CYR - 1 3/8-S	Y-44 -S	YCRS - 22
YR - 1 1/2-X	CYR - 1 1/2-S	Y-48 -S	YCRS - 24
YR - 1 5/8-X	CYR - 1 5/8-S	Y-52 -S	YCRS - 26
YR - 1 3/4-X	CYR - 1 3/4-S	Y-56 -S	YCRS - 28
YR - 1 7/8-X	CYR - 1 7/8-S	Y-60 -S	YCRS - 30
YR - 2-X	CYR - 2-S	Y-64 -S	YCRS - 32
YR - 2 1/4-X	CYR - 2 1/4-S	Y-72 -S	YCRS - 36
YR - 2 1/2-X	CYR - 2 1/2-S	Y-80 -S	YCRS - 40
YR - 2 3/4-X	CYR - 2 3/4-S	Y-88 -S	YCRS - 44
YR - 3-X	CYR - 3-S	Y-96 -S	YCRS - 48
YR - 3 1/4-X	CYR - 3 1/4-S	Y-104 -S	YCRS - 52
YR - 3 1/2-X	CYR - 3 1/2-S	Y-112 -S	YCRS - 56
YR - 4-X	CYR - 4-S	Y-128 -S	YCRS - 64
YR - 5-X	CYR - 5-S	Y-160 -S	YCRS - 80
YR - 6-X	CYR - 6-S	Y-192 -S	YCRS - 96

Optional Features	SMITH®	McGill	RBC	Torrington
Hex-Drive	Add Suffix "B"	Add Suffix "B"	Add Suffix "W"	Add Prefix "B"
Eccentric	Add Suffix "E"	Add Suffix "E"	Add Suffix "X"	Add Prefix "E"
Crowned O.D.	Add Suffix "C"	Add Prefix "C"	Add Prefix "C"	Add Prefix "C"
Thrust Seal	Add Suffix "L"	-	Replace "S" with "L"	-

# Stainless Steel Cam Followers

## Regular Stud Screw-Driver Slot

SMITH®	McGill	Carter
CR-1/2-SS	CF-1/2-CR	SC-16
CR-5/8-SS	CF-5/8-CR	SC-20
CR-3/4-SS	CF-3/4-CR	SC-24
CR-7/8-SS	CF-7/8-CR	SC-28
CR-1-SS	CF-1-CR	SC-32
CR-1 1/8-SS	CF-1 1/8-CR	SC-36
CR-1 1/4-SS	CF-1 1/4-CR	SC-40
CR-1 3/8-SS	CF-1 3/8-CR	SC-44
CR-1 1/2-SS	CF-1 1/2-CR	SC-48
CR-1 5/8-SS	CF-1 5/8-CR	SC-52
CR-1 3/4-SS	CF-1 3/4-CR	SC-56
CR-1 7/8-SS	CF-1 7/8-CR	SC-60
CR-2-SS	CF-2-CR	SC-64
CR-2 1/4-SS	CF-2 1/4-CR	SC-72
CR-2 1/2-SS	CF-2 1/2-CR	-
CR-2 3/4-SS	CF-2 3/4-CR	-
CR-3-SS	CF-3-CR	-
CR-4-SS	CF-4-CR	-

## Regular Stud Hex Socket

SMITH®	McGill	Carter
CR-1/2-B-SS	CF-1/2-B-CR	SC-16-B
CR-5/8-B-SS	CF-5/8-B-CR	SC-20-B
CR-3/4-B-SS	CF-3/4-B-CR	SC-24-B
CR-7/8-B-SS	CF-7/8-B-CR	SC-28-B
CR-1-B-SS	CF-1-B-CR	SC-32-B
CR-1 1/8-B-SS	CF-1 1/8-B-CR	SC-36-B
CR-1 1/4-B-SS	CF-1 1/4-B-CR	SC-40-B
CR-1 3/8-B-SS	CF-1 3/8-B-CR	SC-44-B
CR-1 1/2-B-SS	CF-1 1/2-B-CR	SC-48-B
CR-1 5/8-B-SS	CF-1 5/8-B-CR	SC-52-B
CR-1 3/4-B-SS	CF-1 3/4-B-CR	SC-56-B
CR-1 7/8-B-SS	CF-1 7/8-B-CR	SC-60-B
CR-2-B-SS	CF-2-B-CR	SC-64-B
CR-2 1/4-B-SS	CF-2 1/4-B-CR	SC-72-B
CR-2 1/2-B-SS	CF-2 1/2-B-CR	-
CR-2 3/4-B-SS	CF-2 3/4-B-CR	-
CR-3-B-SS	CF-3-B-CR	-
CR-4-B-SS	CF-4-B-CR	-

## Yoke Type

SMITH®	McGill	Carter
YR-3/4-SS	CYR-3/4-CR	SY-24
YR-7/8-SS	CYR-7/8-CR	SY-28
YR-1-SS	CYR-1-CR	SY-32
YR-1 1/8-SS	CYR-1 1/8-CR	SY-36
YR-1 1/4-SS	CYR-1 1/4-CR	SY-40
YR-1 3/8-SS	CYR-1 3/8-CR	SY-44
YR-1 1/2-SS	CYR-1 1/2-CR	SY-48
YR-1 5/8-SS	CYR-1 5/8-CR	SY-52
YR-1 3/4-SS	CYR-1 3/4-CR	SY-56
YR-1 7/8-SS	CYR-1 7/8-CR	SY-60
YR-2-SS	CYR-2-CR	SY-64
YR-2 1/4-SS	-	SY-72

## Coding for Other Features

Optional Feature	SMITH®	McGILL	Carter
Sealed	add suffix "X"	add suffix "S"	add suffix "S"
Hex-Drive	add suffix "B"	add suffix "B"	add suffix "B"

## I N T E R C H A N G E T A B L E S

## Cam Followers with

## Non-Metallic Bushing

## Stud Type Screw-Driver Slot

SMITH®	McGill	Carter
BCR-1/2	BCF-1/2	N/A
BCR-5/8	BCF-5/8	N/A
BCR-11/16	BCF-11/16	N/A
BCR-3/4	BCF-3/4	N/A
BCR-7/8	BCF-7/8	N/A
BCR-1	BCF-1	N/A
BCR-11/8	BCF-11/8	N/A
BCR-11/4	BCF-11/4	N/A
BCR-13/8	BCF-13/8	N/A
BCR-11/2	BCF-11/2	N/A
BCR-15/8	BCF-15/8	N/A
BCR-13/4	BCF-13/4	N/A
BCR-17/8	BCF-17/8	N/A
BCR-2	BCF-2	N/A
BCR-21/4	BCF-21/4	N/A
BCR-21/2	BCF-21/2	N/A
BCR-23/4	BCF-23/4	N/A
BCR-3	BCF-3	N/A

## Stud Type Hex Socket

SMITH®	McGill	Carter
BCR-1/2-B	BCF-1/2-B	SFH-16-A
BCR-5/8-B	BCF-5/8-B	SFH-20-A
BCR-11/16-B	BCF-11/16-B	SFH-22-A
BCR-3/4-B	BCF-3/4-B	SFH-24-A
BCR-7/8-B	BCF-7/8-B	SFH-28-A
BCR-1-B	BCF-1-B	SFH-32-A
BCR-11/8-B	BCF-11/8-B	SFH-36-A
BCR-11/4-B	BCF-11/4-B	SFH-40-A
BCR-13/8-B	BCF-13/8-B	SFH-44-A
BCR-11/2-B	BCF-11/2-B	SFH-48-A
BCR-15/8-B	BCF-15/8-B	SFH-52-A
BCR-13/4-B	BCF-13/4-B	SFH-56-A
BCR-17/8-B	BCF-17/8-B	SFH-60-A
BCR-2-B	BCF-2-B	SFH-64-A
BCR-21/4-B	BCF-21/4-B	SFH-72-A
BCR-21/2-B	BCF-21/2-B	SFH-80-A
BCR-23/4-B	BCF-23/4-B	SFH-88-A
BCR-3-B	BCF-3-B	SFH-96-A

## Yoke Type

SMITH®	McGill	Carter
BYR-3/4	BCYR-3/4	NYR-24-A
BYR-7/8	BCYR-7/8	NYR-28-A
BYR-1	BCYR-1	NYR-32-A
BYR-11/8	BCYR-11/8	NYR-36-A
BYR-11/4	BCYR-11/4	NYR-40-A
BYR-13/8	BCYR-13/8	NYR-44-A
BYR-11/2	BCYR-11/2	NYR-48-A
BYR-15/8	BCYR-15/8	NYR-52-A
BYR-13/4	BCYR-13/4	NYR-56-A
BYR-17/8	BCYR-17/8	NYR-60-A
BYR-2	BCYR-2	NYR-64-A
BYR-21/4	BCYR-21/4	NYR-72-A
BYR-21/2	BCYR-21/2	NYR-80-A
BYR-23/4	BCYR-23/4	NYR-88-A
BYR-3	BCYR-3	NYR-96-A

## Coding for Other Features

Optional Feature	SMITH®	McGILL
Sealed	add suffix "X"	add suffix "S"



INTERCHANGE TABLES

Metric Cam Followers

STUD TYPE – Caged & Full Complement

SMITH®		McGILL		INA • SKF • NTN		IKO • THK	
Caged	Full Complement	Caged	Full Complement	Caged	Full Complement	Caged	Full Complement
MCR-13	MCRV-13	MCFR-13	MCF-13	–	–	CF5	–
MCR-16	MCRV-16	MCFR-16	MCF-16	KR-16	KRV-16	CF6R	CF6VR
MCR-19	MCRV-19	MCFR-19	MCF-19	KR-19	KRV-19	CF8R	CF8VR
MCR-22	MCRV-22	MCFR-22	MCF-22	KR-22	KRV-22	–	–
–	–	MCFR-22-A	MCF-22A	–	–	CF10R	CF10VR
MCR-26	MCRV-26	MCFR-26	MCF-26	KR-26	KRV-26	–	–
–	–	MCFR-26-A	MCF-26A	–	–	CF10-1R	CF10-1VR
MCR-30	MCRV-30	MCFR-30	MCF-30	KR-30	KRV-30	CF12R	CF12VR
MCR-32	MCRV-32	MCFR-32	MCF-32	KR-32	KRV-32	CF12-1R	CF12-1VR
MCR-35	MCRV-35	MCFR-35	MCF-35	KR-35	KRV-35	CF16R	CF16VR
MCR-40	MCRV-40	MCFR-40	MCF-40	KR-40	KRV-40	–	–
–	–	MCFR-40-A	MCF-40A	–	–	CF18R	CF18VR
MCR-47	MCRV-47	MCFR-47	MCF-47	KR-47	KRV-47	–	–
–	–	MCFR-47-A	MCF-47A	–	–	CF20-1R	CF20-1VR
MCR-52	MCRV-52	MCFR-52	MCF-52	KR-52	KRV-52	–	–
–	–	MCFR-52-A	MCF-52A	–	–	CF20R	CF20VR
MCR-62	MCRV-62	MCFR-62	MCF-62	KR-62	KRV-62	–	–
–	–	MCFR-62-A	MCF-62A	–	–	CF24R	CF24VR
MCR-72	MCRV-72	MCFR-72	MCF-72	KR-72	KRV-72	–	–
–	–	MCFR-72-A	MCF-72A	–	–	CF24-1R	CF24-1VR
MCR-80	MCRV-80	MCFR-80	MCF-80	KR-80	KRV-80	CF30R	CF30VR
MCR-85	MCRV-85	MCFR-85	MCF-85	KR-85	–	CF30-1R	CF30-1VR
MCR-90	MCRV-90	MCFR-90	MCF-90	KR-90	KRV-90	CF30-2R	CF30-2VR

Coding for Other Cam Followers and Yoke Roller Types

Optional Features	SMITH®	McGILL	INA • SKF	IKO	THK	NTN
Sealed	add suffix "S"	add suffix "S"	add suffix "PP"	add suffix "UU"	add suffix "UU"	add suffix "LL"
Cylindrical O.D.	add suffix "C"	add suffix "X"	add suffix "X"	remove suffix "R"	remove suffix "R"	add suffix "X"
Hex-Drive	add suffix "B"	add suffix "B"	add suffix "SK"	add suffix "B"	add suffix "A"	add suffix "H"
Eccentric	add suffix "E"	add prefix "E"	add prefix "E"	add prefix "E"		

YOKE TYPE – Caged & Full Complement

SMITH®		McGILL		INA • SKF • NTN		IKO • THK	
Caged	Full Complement	Caged	Full Complement	Caged	Full Complement	Caged	Full Complement
MYR-5	MYRV-5	MCYRR-5	MCYR-5	NATR-5	NATV-5	NART-5R	NART-5VR
MYR-6	MYRV-6	MCYRR-6	MCYR-6	NATR-6	NATV-6	NART-6R	NART-6VR
MYR-8	MYRV-8	MCYRR-8	MCYR-8	NATR-8	NATV-8	NART-8R	NART-8VR
MYR-10	MYRV-10	MCYRR-10	MCYR-10	NATR-10	NATV-10	NART-10R	NART-10VR
MYR-12	MYRV-12	MCYRR-12	MCYR-12	NATR-12	NATV-12	NART-12R	NART-12VR
MYR-15	MYRV-15	MCYRR-15	MCYR-15	NATR-15	NATV-15	NART-15R	NART-15VR
MYR-17	MYRV-17	MCYRR-17	MCYR-17	NATR-17	NATV-17	NART-17R	NART-17VR
MYR-20	MYRV-20	MCYRR-20	MCYR-20	NATR-20	NATV-20	NART-20R	NART-20VR
MYR-25	MYRV-25	MCYRR-25	MCYR-25	NATR-25	NATV-25	NART-25R	NART-25VR
MYR-30	MYRV-30	MCYRR-30	MCYR-30	NATR-30	NATV-30	NART-30R	NART-30VR
MYR-35	MYRV-35	MCYRR-35	MCYR-35	NATR-35	NATV-35	NART-35R	NART-35VR
MYR-40	MYRV-40	MCYRR-40	MCYR-40	NATR-40	NATV-40	NART-40R	NART-40VR
MYR-45	MYRV-45	MCYRR-45	MCYR-45	NATR-45	–	NART-45R	NART-45VR
MYR-50	MYRV-50	MCYRR-50	MCYR-50	NATR-50	NATV-50	NART-50R	NART-50VR

## Metric Cam Followers

## Double Row • Heavy Rollers • Screwdriver Slot • Shielded • Full Complement

SMITH® • INA	McGILL
NUKR-35	MCFD-35
NUKR-40	MCFD-40
NUKR-47	MCFD-47
NUKR-52	MCFD-52
NUKR-62	MCFD-62
NUKR-72	MCFD-72
NUKR-80	MCFD-80
NUKR-85	MCFD-85
NUKR-90	MCFD-90



## Double Row • Heavy Rollers • Yoke Type • Shielded • Full Complement

SMITH®	McGILL	INA
MUTD-15	MCYRD-15	NUTR-15
MUTD-17	MCYRD-17	NUTR-17
MUTD-1542	MCYRD-1542	NUTR-1542
MUTD-1747	MCYRD-1747	NUTR-1747
MUTD-20	MCYRD-20	NUTR-20
MUTD-2052	MCYRD-2052	NUTR-2052
MUTD-25	MCYRD-25	NUTR-25
MUTD-2562	MCYRD-2562	NUTR-2562
MUTD-30	MCYRD-30	NUTR-30
MUTD-3072	MCYRD-3072	NUTR-3072
MUTD-35	MCYRD-35	NUTR-35
MUTD-3580	MCYRD-3580	NUTR-3580
MUTD-40	MCYRD-40	NUTR-40
MUTD-45	MCYRD-45	NUTR-45
MUTD-4090	MCYRD-4090	NUTR-4090
MUTD-50	MCYRD-50	NUTR-50
MUTD-45100	MCYRD-45100	NUTR-45100
MUTD-50110	MCYRD-50110	NUTR-50110



# INCH SIZES



## Track Roller Bearings

### Plain Track Rollers

SMITH®	McGill	Osborn	PCI
PCR-1-1/2	PCF-1-1/2	PLR-1-1/2	PTR-1.50
PCR-1-3/4	PCF-1-3/4	PLR-1-3/4	PTR-1.75
PCR-2	PCF-2	PLR-2	PTR-2.00
PCR-2-1/4	PCF-2-1/4	PLR-2-1/4	PTR-2.25
PCR-2-3/4	PCF-2-3/4	PLR-2-3/4	PTR-2.75
PCR-3	PCF-3	PLR-3	PTR-3.00
PCR-3-1/4	PCF-3-1/4	PLR-3-1/4	PTR-3.25
PCR-3-1/2	PCF-3-1/2	PLR-3-1/2	PTR-3.50
PCR-4	PCF-4	PLR-4	PTR-4.00
PCR-4-1/2	PCF-4-1/2	PLR-4-1/2	PTR-4.50
PCR-5	PCF-5	PLR-5	PTR-5.00
PCR-6	PCF-6	PLR-6	PTR-6.00
PCR-7	PCF-7	PLR-7	PTR-7.00
PCR-8	PCF-8	PLR-8	PTR-8.00

### Flanged Track Rollers

SMITH®	McGill	Osborn	PCI
FCR-1-1/2	FCF-1-1/2	FLR-1-1/2	FTR-1.50
FCR-1-3/4	FCF-1-3/4	FLR-1-3/4	FTR-1.75
FCR-2	FCF-2	FLR-2	FTR-2.00
FCR-2-1/4	FCF-2-1/4	FLR-2-1/4	FTR-2.25
FCR-2-1/2	FCF-2-1/2	FLR-2-1/2	FTR-2.50
FCR-2-3/4	FCF-2-3/4	FLR-2-3/4	FTR-2.75
FCR-3	FCF-3	FLR-3	FTR-3.00
FCR-3-1/4	FCF-3-1/4	FLR-3-1/4	FTR-3.25
FCR-3-1/2	FCF-3-1/2	FLR-3-1/2	FTR-3.50
FCR-4	FCF-4	FLR-4	FTR-4.00
FCR-4-1/2	FCF-4-1/2	FLR-4-1/2	FTR-4.50
FCR-5	FCF-5	FLR-5	FTR-5.00
FCR-6	FCF-6	FLR-6	FTR-6.00
FCR-7	FCF-7	FLR-7	FTR-7.00
FCR-8	FCF-8	FLR-8	FTR-8.00

### V-Grooved Track Rollers

SMITH	McGill	Osborn	PCI
VCR-3-1/2	VCF-3-1/2	VLR-3-1/2	VTR-3.50
VCR-4-1/2	VCF-4-1/2	VLR-4-1/2	VTR-4.50
VCR-5-1/2	VCF-5-1/2	VLR-5-1/2	VTR-5.50
VCR-6-1/2	VCF-6-1/2	VLR-6-1/2	VTR-6.50
VCR-7-1/2	VCF-7-1/2	VLR-7-1/2	VTR-7.50
VCR-8-1/2	VCF-8-1/2	VLR-8-1/2	VTR-8.50

### U-Grooved Track Rollers

SMITH®	McGill	Osborn	PCI
UCR-2-15/16-1	UCF-2-15/16-1	ULR-2-15/16-A	UTR-2.9375-A
UCR-2-15/16-2	UCF-2-15/16-2	ULR-2-15/16-B	UTR-2.9375-B
UCR-2-15/16-3	UCF-2-15/16-3	ULR-2-15/16-C	UTR-2.9375-C
UCR-2-15/16-4	UCF-2-15/16-4	ULR-2-15/16-D	UTR-2.9375-D
UCR-2-15/16-5	UCF-2-15/16-5	ULR-2-15/16-E	UTR-2.9375-E
UCR-2-15/16-6	UCF-2-15/16-6	ULR-2-15/16-F	UTR-2.9375-F
UCR-2-15/16-7	UCF-2-15/16-7	ULR-2-15/16-G	UTR-2.9375-G
UCR-2-15/16-8	UCF-2-15/16-8	ULR-2-15/16-H	UTR-2.9375-H
UCR-2-15/16-9	UCF-2-15/16-9	ULR-2-15/16-I	UTR-2.9375-I
UCR-2-15/16-10	UCF-2-15/16-10	ULR-2-15/16-J	UTR-2.9375-J

## Yoke Track Roller Bearings

### Plain Yoke Rollers

SMITH®	Osborn	PCI
PYR-3	PLRY-3	PTRY-3.00
PYR-3-1/4	PLRY-3-1/4	PTRY-3.25
PYR-3-1/2	PLRY-3-1/2	PTRY-3.50
PYR-4	PLRY-4	PTRY-4.00
PYR-5	PLRY-5	PTRY-5.00
PYR-6	PLRY-6	PTRY-6.00
PYR-7	PLRY-7	PTRY-7.00
PYR-8	PLRY-8	PTRY-8.00

### Flanged Yoke Rollers

SMITH®	Osborn	PCI
FYR-3	FLRY-3	FTRY-3.00
FYR-3-1/4	FLRY-3-1/4	FTRY-3.25
FYR-3-1/2	FLRY-3-1/2	FTRY-3.50
FYR-4	FLRY-4	FTRY-4.00
FYR-5	FLRY-5	FTRY-5.00
FYR-6	FLRY-6	FTRY-6.00
FYR-7	FLRY-7	FTRY-7.00
FYR-8	FLRY-8	FTRY-8.00

### V-Grooved Yoke Rollers

SMITH®	Osborn	PCI
VYR-4-1/2	VLRY-4-1/2	VTRY-4.50
VYR-5-1/2	VLRY-5-1/2	VTRY-5.50
VYR-6-1/2	VLRY-6-1/2	VTRY-6.50
VYR-7-1/2	VLRY-7-1/2	VTRY-7.50
VYR-8-1/2	VLRY-8-1/2	VTRY-8.50

### Coding for Other Track Rollers

Optional Feature	SMITH®	Osborn	McGILL	PCI
Eccentric Collar	add suffix "E"	add prefix "E"	add prefix "E"	add prefix "E"



MPCR

MFCR

MVCR

MPYR

MFYR

MVYR

# METRIC SIZES

SMITH-TRAX® Interchange

## Track Roller Bearings

### Plain Track Rollers

SMITH®	Osborn
MPCR-26	HPC-26
MPCR-30	HPC-30
MPCR-32	HPC-32
MPCR-35	HPC-35
MPCR-40	HPC-40
MPCR-47	HPC-47
MPCR-50	HPC-50
MPCR-52	HPC-52
MPCR-62	HPC-62
MPCR-72	HPC-72
MPCR-76	HPC-76
MPCR-80	HPC-80
MPCR-85	HPC-85
MPCR-90	HPC-90
MPCR-100	HPC-100
MPCR-125	HPC-125
MPCR-150	HPC-150
MPCR-200	HPC-200

### V-Grooved Track Rollers

SMITH®	Osborn
MVCR-26	HPV-26
MVCR-32	HPV-32
MVCR-40	HPV-40
MVCR-62	HPV-62
MVCR-76	HPV-76
MVCR-100	HPV-100
MVCR-125	HPV-125

### Flanged Track Rollers

SMITH®	Osborn
MFCR-26	HPJ-26
MFCR-30	HPJ-30
MFCR-32	HPJ-32
MFCR-35	HPJ-35
MFCR-40	HPJ-40
MFCR-47	HPJ-47
MFCR-50	HPJ-50
MFCR-52	HPJ-52
MFCR-62	HPJ-62
MFCR-72	HPJ-72
MFCR-76	HPJ-76
MFCR-80	HPJ-80
MFCR-85	HPJ-85
MFCR-90	HPJ-90
MFCR-100	HPJ-100
MFCR-125	HPJ-125
MFCR-150	HPJ-150
MFCR-200	HPJ-200

## Yoke Track Roller Bearings

### Plain Yoke Rollers

SMITH®	Osborn
MPYR-62	HPCA-62
MPYR-76	HPCA-76
MPYR-80	HPCA-80
MPYR-85	HPCA-85
MPYR-90	HPCA-90
MPYR-100	HPCA-100
MPYR-125	HPCA-125
MPYR-150	HPCA-150
MPYR-200	HPCA-200
MPYR-250	HPCA-250

### V-Grooved Yoke Rollers

SMITH®	Osborn
MVYR-62	HPVA-62
MVYR-76	HPVA-76
MVYR-100	HPVA-100
MVYR-125	HPVA-125
MVYR-150	HPVA-150
MVYR-200	HPVA-200
MVYR-250	HPVA-250

### Flanged Yoke Rollers

SMITH®	Osborn
MFYR-62	HPJA-62
MFYR-76	HPJA-76
MFYR-80	HPJA-80
MFYR-85	HPJA-85
MFYR-90	HPJA-90
MFYR-100	HPJA-100
MFYR-125	HPJA-125
MFYR-150	HPJA-150
MFYR-200	HPJA-200
MFYR-250	HPJA-250

### Coding for Other Track Rollers

Optional Feature	SMITH®	Osborn
Eccentric Collar	add suffix "E"	add prefix "E"

MILITARY Standard Number	TORRINGTON Number	McGILL Number	SMITH® Number
24465-3	3NBF512YJ	3NBF512YJ	YAD-03
24465-4	4NBF614YJ	4NBF614YJ	YAD-04
24465-6	6NBF817YJ	6NBF817YJ	YAD-06
24465-8	8NBF1021YJ	8NBF1021YJ	YAD-08
24465-10	10NBF1224YJ	10NBF1224YJ	YAD-10
24465-12	12NBF1628YJ	12NBF1628YJ	YAD-12
24465-14	14NBF1832YJ	14NBF1832YJ	YAD-14
24465-20	20NBF2040YJ	20NBF2040YJ	YAD-20
24465-24	24NBF2448YJ	24NBF2448YJ	YAD-24
24465-28	28NBF2455YJ	28NBF2455YJ	YAD-28
24465-32	32NBF2462YJ	32NBF2462YJ	YAD-32
24465-36	36NBF2469YJ	36NBF2469YJ	YAD-36
24465-40	40NBF2476YJ	40NBF2476YJ	YAD-40
24465-44	44NBF2480YJ	44NBF2476YJ	YAD-44
24466-6	6NBL1618YJ	6NBL1618YJ	YAS-06
24466-8	8NBL2022YJ	8NBL2022YJ	YAS-08
24466-10	10NBL2426YJ	10NBL2426YJ	YAS-10
24466-12	12NBL2830YJ	12NBL2830YJ	YAS-12
21432-3	HRS-1C	HRS-1C	HRS-1C
21432-4	HRS-2C	HRS-2C	HRS-2C
21432-5	HRS-3C	HRS-3C	HRS-3C
21432-6	HRS-4C	HRS-4C	HRS-4C
21432-7	HRS-5C	HRS-5C	HRS-5C
21432-8	HRS-6C	HRS-6C	HRS-6C
21447-3	CHRS-1C	CHRS-1C	CHRS-1C
21447-4	CHRS-2C	CHRS-2C	CHRS-2C
21447-5	CHRS-3C	CHRS-3C	CHRS-3C
21447-6	CHRS-4C	CHRS-4C	CHRS-4C
21447-7	CHRS-5C	CHRS-5C	CHRS-5C
21447-8	CHRS-6C	CHRS-6C	CHRS-6C
21438-103	ATF-3	3 AFC 512	YAF-03
21438-104	ATF-4	4 AFC 614	YAF-04
21438-106	ATF-6	6 AFC 817	YAF-06
21438-108	ATF-8	8 AFC 1021	YAF-08
21438-110	ATF-10	10 AFC 1224	YAF-10
21438-112	ATF-12	12 AFC 1628	YAF-12

## INTERCHANGE TABLES

MILITARY Standard Number	TORRINGTON Number	McGILL Number	SMITH® Number
21438-114	ATF-14	14 AFC 1832	YAF-14
21438-120	ATF-20	20 AFC 2040	YAF-20
21438-124	ATF-24	24 AFC 2448	YAF-24
21438-128	ATF-28	28 AFC 2455	YAF-28
21438-132	ATF-32	32 AFC 2462	YAF-32
21438-136	ATF-36	36 AFC 2469	YAF-36
21438-140	ATF-40	40 AFC 2476	YAF-40
21438-144	ATF-44	44 AFC 2480	YAF-44
21439-106	ATL-6	6 AL 1618	YAT-06
21439-108	ATL-8	8 AL 2022	YAT-08
21439-110	ATL-10	10 AL 2426	YAT-10
21439-112	ATL-12	12 AL 2830	YAT-12
24461-3	3NBC511ZP	3NBC511ZP	YAG-03-C
24461-4	4NBC612ZP	4NBC612ZP	YAG-04-C
24461-5	5NBC713ZP	5NBC713ZP	YAG-05-C
24461-6	6NBC914YZP	6NBC914YZP	YAG-06
24461-7	7NBC1015YZP	7NBC1015YZP	YAG-07
24461-8	8NBC1218YZP	8NBC1218YZP	YAG-08
24461-9	9NBC1419YZP	9NBC1419YZP	YAG-09
24461-10	10NBC1620YZP	10NBC1620YZP	YAG-10
24461-12	12NBC1822YZP	12NBC1822YZP	YAG-12
24461-14	14NBC2026YZP	14NBC2026YZP	YAG-14
24461-16	16NBC2028YZP	16NBC2028YZP	YAG-16
24461-20	20NBC2032YZP	20NBC2032YZP	YAG-20
24461-24	24NBC2036YZP	24NBC2036YZP	YAG-24
24461-28	28NBC2040YZP	28NBC2040YZP	YAG-28
24461-32	32NBC2044YZP	32NBC2044YZP	YAG-32
24461-36	36NBC2048YZP	36NBC2048YZP	YAG-36
24461-40	40NBC2052YZP	40NBC2052YZP	YAG-40
24461-44	44NBC2056YZP	44NBC2056YZP	YAG-44
24461-48	48NBC2060YZP	48NBC2060YZP	YAG-48
24461-52	52NBC2064YZP	52NBC2064YZP	YAG-52
24461-56	56NBC2070YZP	56NBC2070YZP	YAG-56
24461-60	60NBC2074YZP	60NBC2074YZP	YAG-60
24461-64	64NBC2078YZP	64NBC2078YZP	YAG-64











**1. ACCEPTANCE BY BUYER**

Acceptance of this sales order or quotation by buyer **IS EXPRESSLY LIMITED TO THE TERMS AND CONDITIONS HEREIN CONTAINED.** Any item or condition in any purchase order or other form in conflict with the terms or conditions of this sales order or quotation is hereby expressly rejected and shall not be binding on Seller. If these terms and conditions differ in any way from terms and conditions of Buyer's order, or other documentation, this document will be construed as a counteroffer and will not be deemed an acceptance of Buyer's terms and conditions which conflict herewith. This quotation may be withdrawn by Seller at any time prior to acceptance by Buyer of each and every term and condition hereof, and will expire automatically upon (90) days from the date hereof unless accepted by Buyer. On all orders, the prices shown and acknowledged at the time of entry will be subject to revision in accordance with Seller's price schedules in effect at time of shipment. All sales, contracts and orders become effective only when approved and accepted in writing by Seller on Seller's sales order or acknowledgment.

**2. PRICES - Prices are**

- a) subject to change without notice prior to acceptance of Buyer's order by Seller, unless quoted otherwise in writing by Seller.
- b) exclusive of all federal, state, municipal or other government excise, sales, use occupational or like taxes now in force or to be enacted in the future.
- c) subject to an increase equal in the amount to any tax the Seller may be required to collect or pay upon the sales of the items quoted.
- d) quoted F.O.B., place of manufacture.
- e) subject to change at any time by Seller in the event of any change in the Buyer's requirements or the terms and conditions of this quotation.

**3. TERMS**

- a) Invoices will be issued under date of shipment with terms of net thirty (30) days from date of invoice, subject to such change as Seller's home office may impose because of financial or credit conditions existing at time of shipment. In the event of an order for several units, each unit will be invoiced when shipped.
- b) Seller reserves the right to modify these terms for export business and special projects.

**4. BUYERS CREDIT**

If the financial responsibility of the Buyer becomes impaired or unsatisfactory to Seller or if Buyer is in default to Seller under this or any other contract, advance cash payment or satisfactory security shall be given by Buyer upon demand by Seller and shipments may be withheld until such payment or security is received.

**5. SHIPPING ESTIMATES**

- a) The shipping date shown in this sales order or quotation is approximate and dependent upon prior sales and circumstances beyond Seller's control.
- b) Shipping date will be computed from the date or receipt of all data required to enable complete engineering or acceptance of buyers order as provided in Section 1 above, whichever is later.
- c) Every effort will be made to effect shipment within the time stated, but Seller will not be liable for any damages resulting directly or indirectly from fire, embargo, strikes, or acts of God, civil strife or insurrection, transportation delay, whether at place of manufacture or elsewhere, or from delay by reason of any rule, regulation or order of any governmental authority directly affecting delivery or from causes beyond seller's control.
- d) Any changes in customer's requirements will require confirmation or revision of estimated shipping date.

**6. DELIVERY**

All goods shall be shipped F.O.B. the stated shipping point. Seller shall have the right to select the carrier unless the carrier is designated by the Buyer and upon delivery of the goods by the Seller to the carrier, the carrier shall be deemed to be the agent of the Buyer and thereafter risk of loss shall be on the buyer.

**7. WARRANTY**

- a) Seller warrants that the Buyer will receive good title to the product and that such part of the product manufactured by the Seller will be free from defects which are not commercially acceptable in material and workmanship for a period of ninety (90) days from date of shipment, when used by the Buyer in accordance with the instructions as to maintenance and operation recommended by Seller. In no event shall this warranty extend to or obligate Seller in any way regarding parts or components in the product not actually manufactured by Seller, but Seller's warranty in respect to any such parts and components manufactured by others is hereby expressly limited to the warranty of the original manufacturer of such item or component. A copy of the original manufacturer's warranty of such items or products will be submitted to the Buyer upon request.
- b) This warranty is void and of no effect and Seller shall not be liable for any breach of warranty, express or implied. If the product or any part or component thereof shall have been repaired or altered by persons other than the Seller unless expressly authorized in writing by the Seller, or if the product is operated or installed contrary to Seller's instructions or subjected to misuse, negligence or accident.
- c) THERE ARE NO OTHER WARRANTIES THAT EXTEND BEYOND THE WARRANTY HEREIN CONTAINED and no statement, oral or written, inconsistent with this warranty is binding on Seller. No agent, employee or representative of the Seller has any authority to bind the Seller to any confirmation, representation or warranty concerning the product that is the subject of this quotation beyond that specifically included in this written quotation or sales order. Extension of or amendment of this warranty can be made only in writing by a authorized officer of the Seller.
- d) This warranty is made IN LIEU OF ALL OTHER WARRANTIES, EXPRESSED OR IMPLIED, including any warranty of MERCHANTABILITY or FITNESS for a particular purpose.
- e) Seller's remedy for breach of any warranty shall be limited as in the next section provided.

**8. REMEDY FOR BREACH OF WARRANTY AND LIMITATION OF LIABILITY**

- a) Seller agrees to repair or replace without cost any part of the product manufactured by the Seller that, for the period of ninety (90) days specified in Section 6 above, may prove upon Seller's inspection, to be defective in material or workmanship and not commercially acceptable.
- b) Seller shall have the option to inspect any parts claimed to be defective either at Seller's place of business or Buyer's place of business. No return shall be accepted unless Seller has had an opportunity to inspect the product or has expressly authorized the return.
- c) Under no circumstances shall Seller be liable for consequential or incidental damages resulting from any breach of warranty even though Seller may have been advised of the possibility of such damages. Seller's liability for breach of any warranty shall not exceed the purchase price of the product less the value of the product at any time of acceptance.

- d) Any claim for breach of Seller's warranty herein contained must be made in writing addressed to the Seller setting forth in sufficient detail to permit identification of the defect. Any claim for breach of warranty must be made within twelve (12) months after installation on Buyer's premises of the product. If not made within said twelve (12) month period it shall be conclusively deemed to have been waived.
- e) The remedies for breach of warranty herein contained shall be exclusive.

**9. RESERVATION OF RIGHTS IN RESPECT TO SELLERS OTHER PRODUCTS**

- a) Seller reserves the right to make improvements and changes in design upon its products without imposing any obligation to make such changes or improvements upon the product that is the subject of this order or on product previously manufactured and sold by it.

**10. LIMITATION OF ACTIONS**

Any action for breach of Seller's warranty must be commenced within twelve (12) months from the time the cause of actions accrues unless the period for action shall be extended by Seller's writing. In the interpretation of this limitation on action for breach of Seller's warranty, it is expressly agreed that there are no warranties of future performance of the product that extend the period of limitation herein contained for bringing an action.

**11. CANCELLATION**

In the event Buyer requests a Seller to stop work or cancel the order or any part thereof, cancellation charges shall be paid to Seller as follows:

- a) Any and all work that is complete on the date of notification in writing to stop work or to cancel shall be invoiced and paid in full.
- b) For work in process and any materials and supplies procured or for which definite commitments have been made by Seller in connection with the Buyer shall pay the actual costs and overhead expenses determined in accordance with good accounting practices.
- c) Buyer shall promptly instruct Seller as to the disposition of the product and the latter shall, if requested, hold the product for Buyer's account. All costs of storage, insurance handling, boxing or other costs in connection therewith shall be borne by the Buyer.

**12. COMPLETE AGREEMENT**

This quotation or sales order when accepted by the Buyer without condition and acknowledgment of receipt of the acceptance is given to the Buyer shall constitute the entire agreement between the Buyer and Seller and supersedes all proposals, oral or written and all other communications between the parties relating to the subject matter of this quotation. No alteration or addition to this quotation shall bind the Seller unless expressly assented to in writing by a duly authorized officer of the company.