

301 L

301 R

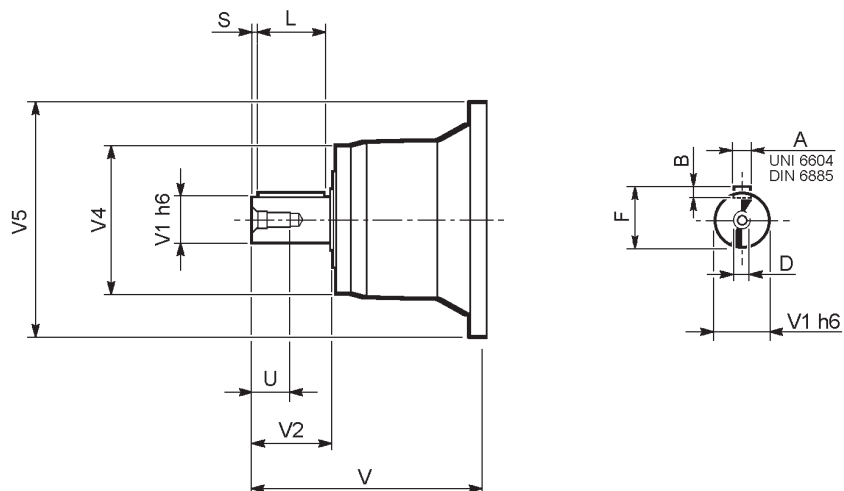

	CODE	V	V1	V2	V4	V5	A	B	F	L	S	D	U
301 L1	V01A	137.5	24	36	120	186	8	7	27	30	3	M8	19
	V01B	158	38	58	120	186	10	8	41	50	4	M12	28
301 L2	V01A	137.5	24	36	120	186	8	7	27	30	3	M8	19
	V01B	158	38	58	120	186	10	8	41	50	4	M12	28
301 L3	V01A	137.5	24	36	120	186	8	7	27	30	3	M8	19
	V01B	158	38	58	120	186	10	8	41	50	4	M12	28
301 L4	V01A	137.5	24	36	120	186	8	7	27	30	3	M8	19
	V01B	158	38	58	120	186	10	8	41	50	4	M12	28
301 R2-R3-R4	V01A	137.5	24	36	120	186	8	7	27	30	3	M8	19
	V01B	158	38	58	120	186	10	8	41	50	4	M12	28

3/V 01L3

3/A 01L2

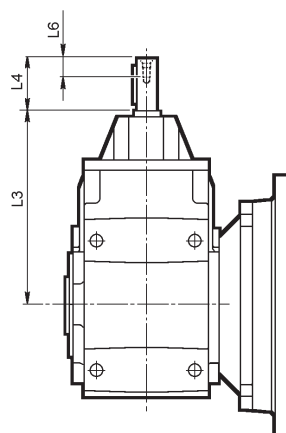
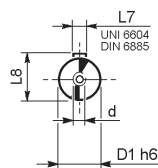
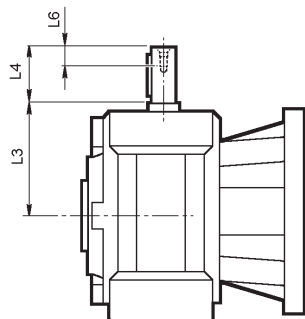
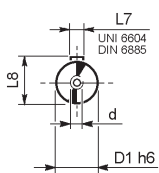

	D1 h6	L3	L4	L6	L7	L8	d
3/V 01L3_HS	16	65	40	16	5	18	M6

	D1 h6	L3	L4	L6	L7	L8	d
3/A 01L2_HS	19	235.5	40	16	6	21.5	M6

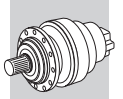

Fattore di posizione per carichi radiali sugli alberi in uscita.

Load location factor for radial loading on output shaft.

Positionsfaktor für Radialkräfte an der Abtriebswelle.

Facteur de position pour charges radiales sur les arbres en sortie.

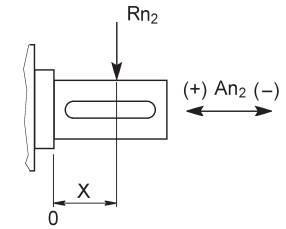
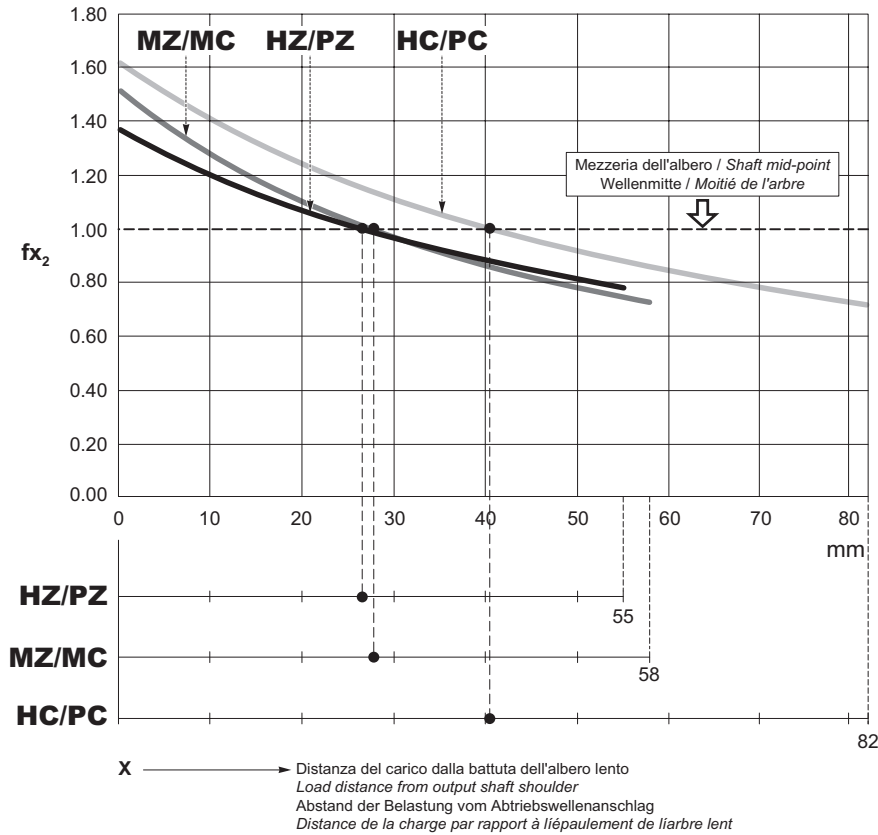

$$R_{x2} = R_{n2} \cdot f_{x2}$$

$An_2 (\pm) = R_{n2} \cdot fa_2 (\pm)$		
	$fa_2 (+)$	$fa_2 (-)$
HZ/PZ	1.18	1.18
HC/PC	1.29	1.29
MC	2.20	2.20
MZ	2.04	2.04

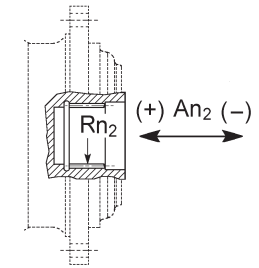

$$An_2 (\pm) = R_{n2} \cdot fa_2 (\pm)$$

	$fa_2 (+)$	$fa_2 (-)$
FZ	1.00	1.00

Carichi radiali ammissibili sull'albero veloce per $n_1 = 1000 \text{ min}^{-1}$ e 10000 h di vita teorica.

Permitted overhung loads on input shaft when $n_1 = 1000 \text{ min}^{-1}$ and theoretical lifetime = 10000 h.

Zulässige Radialkräfte an den Antriebswellen für $n_1 = 1000 \text{ min}^{-1}$ und 10000 std.

Charges radiales admissibles sur les arbres d'entrée pour $n_1 = 1000 \text{ min}^{-1}$ et 10000 h.

Per velocità di comando e/o durate diverse vedi il capitolo: Verifiche.

For drive speed and/or lifetimes other than those specified here, see Chapter: Verifications.

Im Hinblick auf Geschwindigkeit und/oder anderweitige Dauern verweisen wir auf Par: Prüfungen

Pour des vitesses et/ou durées différentes, voir par. Vérifications.

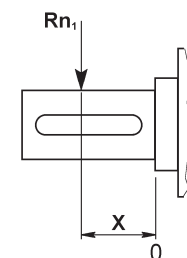
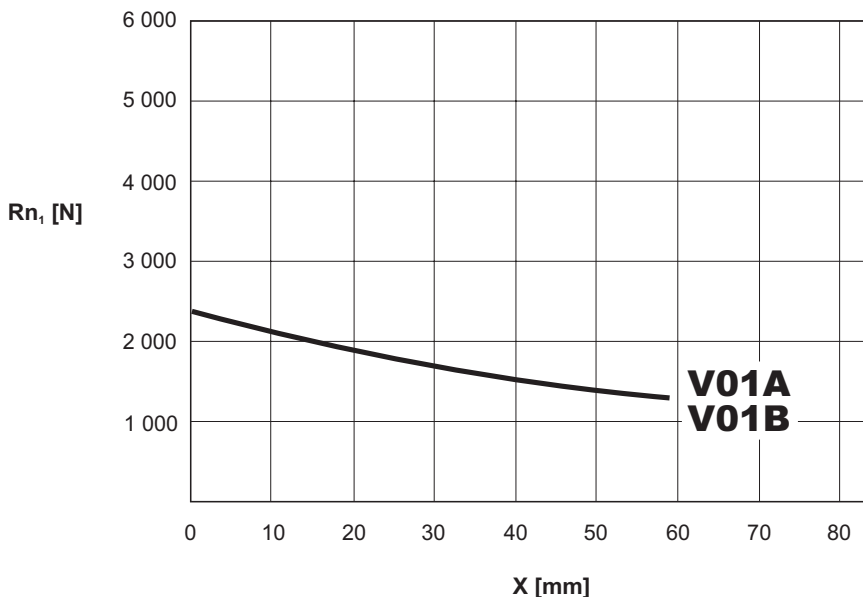

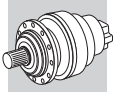

303 L

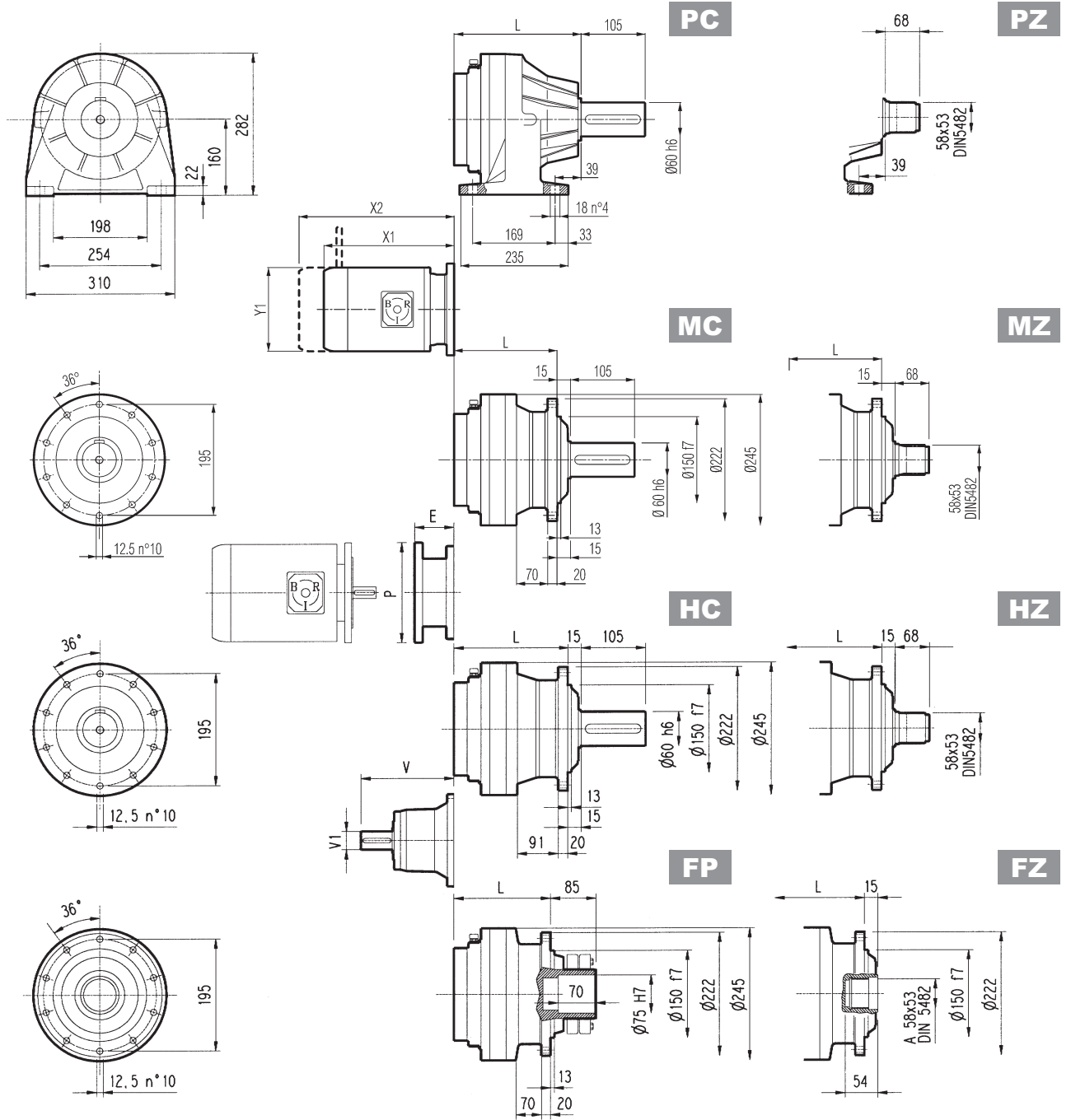

FP

$M_{2max} = 3\ 500\ \text{Nm}$

	L				Kg				Albero veloce / Input shaft / Antriebswelle / Arbre d'entrée					
	MC - MZ	PC - PZ	HC - HZ	FP - FZ	MC - MZ	PC - PZ	HC - HZ	FP - FZ	V	V1	Kg	V	V1	Kg
303 L1	125	165	150	125	31	40	35	31	239	48	15	-	-	-
303 L2	178	218	203	178	35	44	39	35	137.5	24	6	158	38	7
303 L3	231	271	256	231	39	48	43	39	137.5	24	6	158	38	7
303 L4	284	324	309	284	43	52	47	43	137.5	24	6	158	38	7

	P71		P80		P90		P100		P112		P132		P160		P180	
	E	P	E	P	E	P	E	P	E	P	E	P	E	P	E	P
303 L1	-	-	-	-	-	-	-	-	-	-	114	300	144	350	144	350
303 L2	65	160	84	200	84	200	94	250	94	250	114	300	-	-	-	-
303 L3	65	160	84	200	84	200	94	250	94	250	114	300	-	-	-	-
303 L4	65	160	84	200	84	200	94	250	94	250	114	300	-	-	-	-

	S1 - M1S			S1 - M1L			S2 - M2S			S3 - M3S			S3 - M3L			S4 - M4			S5 - M5S			S5 - M5L		
	X1	X2	Y1	X1	X2	Y1	X1	X2	Y1	X1	X2	Y1	X1	X2	Y1	X1	X2	Y1	X1	X2	Y1	X1	X2	Y
303 L1	-	-	-	-	-	-	-	-	-	-	-	-	-	-	-	460	571	258	552	692	310	596	736	310
303 L2	229	292	138	253	314	138	280	352	156	325	421	195	357	449	195	460	571	258	-	-	-	-	-	-
303 L3	229	292	138	253	314	138	280	352	156	325	421	195	357	449	195	460	571	258	-	-	-	-	-	-
303 L4	229	292	138	253	314	138	280	352	156	325	421	195	357	449	195	460	571	258	-	-	-	-	-	-

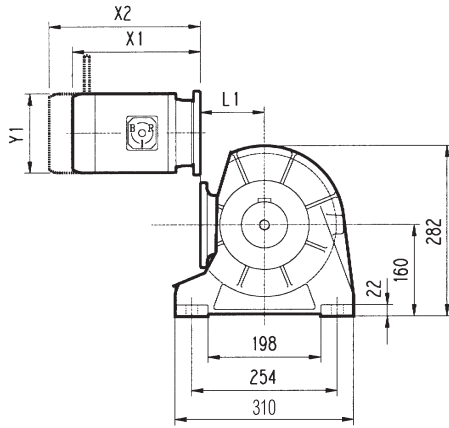
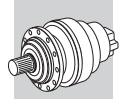

PC

PZ

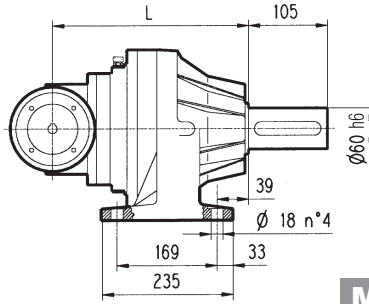

MC

MZ

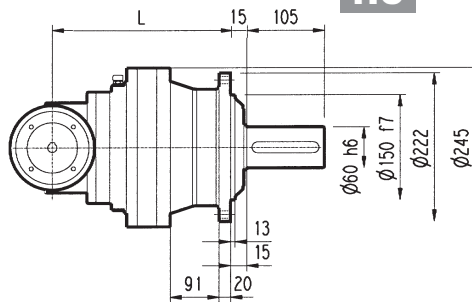
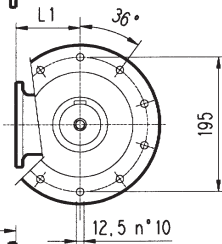
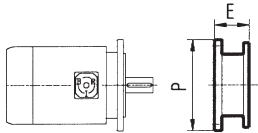
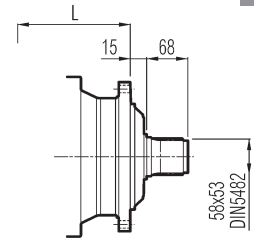
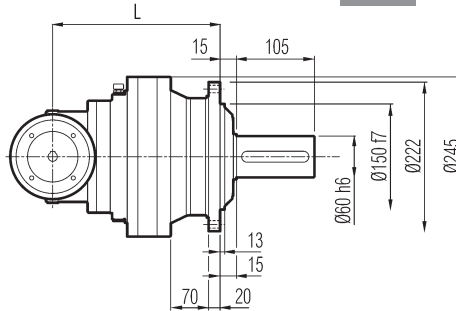
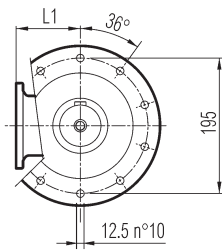
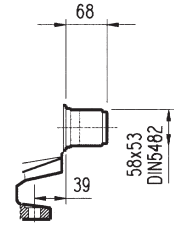

HC

HZ

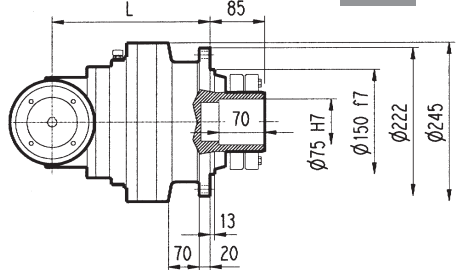
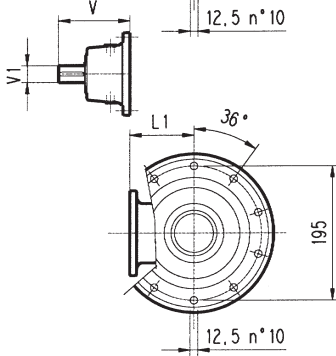
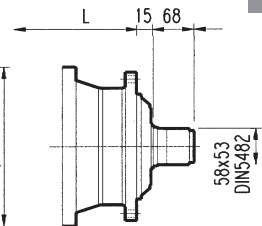

FP

FZ

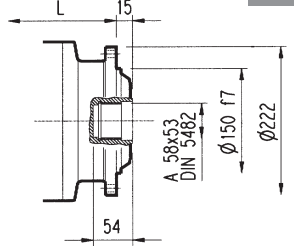

FP $M_{2max} = 3\ 500\ Nm$

	L				L1	Kg				Albero veloce / Input shaft / Antriebswelle / Arbre d'entrée								
	MC - MZ	PC - PZ	HC - HZ	FP - FZ		MC - MZ	PC - PZ	HC - HZ	FP - FZ	V	V1	Kg	V	V1	Kg			
303 R2	217	257	242	217	140	51	60	55	51	137.5	24	6	158	38	7			
303 R3	270	310	295	270	122	49	58	53	49	137.5	24	6	158	38	7			
303 R4	323	363	348	323	122	53	62	57	53	137.5	24	6	158	38	7			
	P71		P80		P90		P100		P112		P132							
	E	P	E	P	E	P	E	P	E	P	E	P						
303 R2	65	160	84	200	84	200	94	250	94	250	114	300						
303 R3	65	160	84	200	84	200	94	250	94	250	-	-						
303 R4	65	160	84	200	84	200	94	250	94	250	-	-						
	S1 - M1S			S1 - M1L			S2 - M2S			S3 - M3S			S3 - M3L			S4 - M4		
	X1	X2	Y1	X1	X2	Y1	X1	X2	Y1	X1	X2	Y1	X1	X2	Y1	X1	X2	Y1
303 R2	-	-	-	-	-	-	328	400	156	373	469	195	405	497	195	508	619	258
303 R3	229	292	138	253	314	138	328	400	156	373	469	195	405	497	195	-	-	-
303 R4	229	292	138	253	314	138	328	400	156	373	469	195	405	497	195	-	-	-

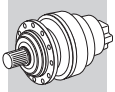

3/V 03L3

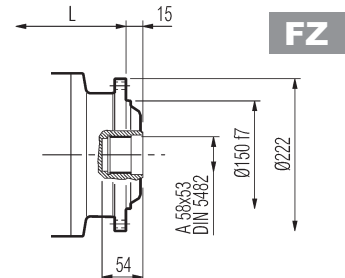
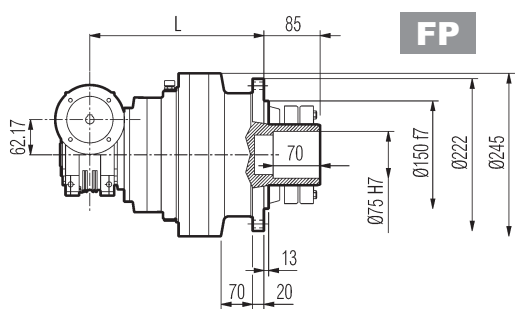
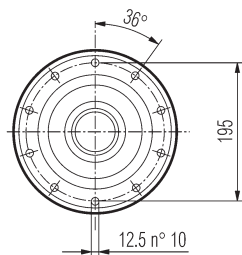
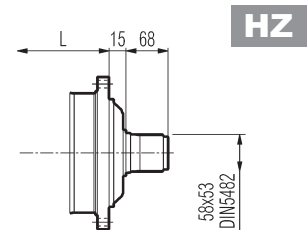
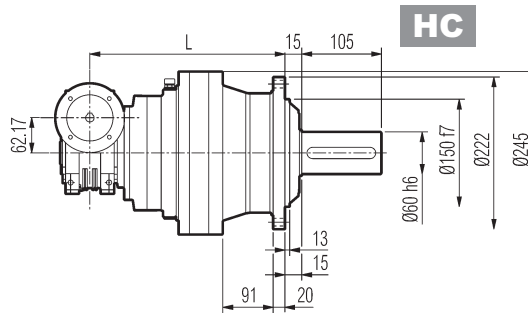
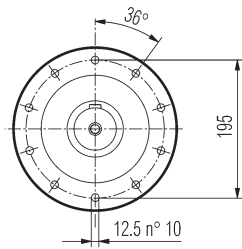
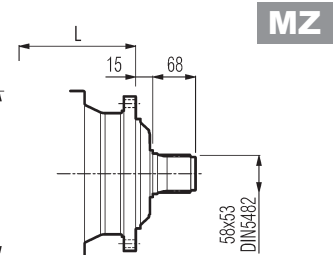
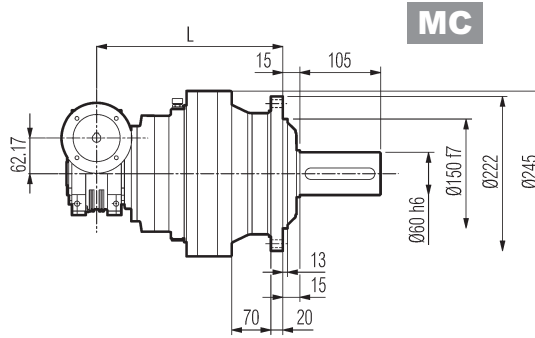
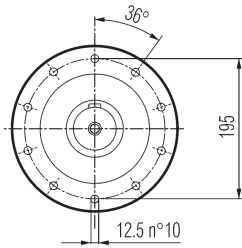
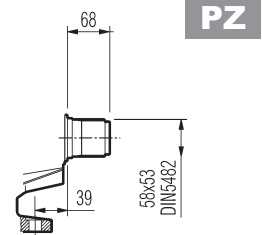
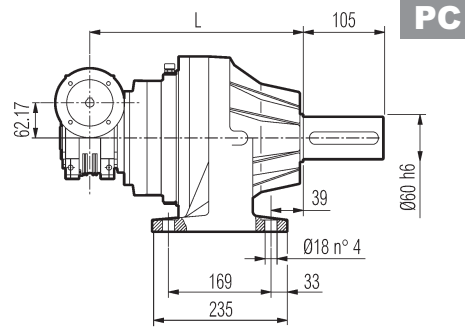
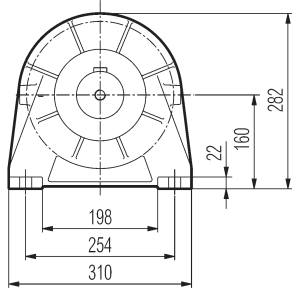

VISTA DA A
VIEW FROM A

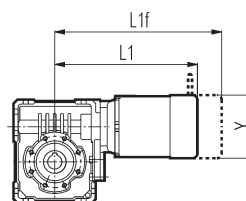
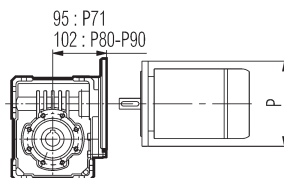
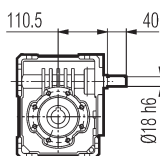

FP

$M_{2max} = 3\ 500\ \text{Nm}$

3/V 03L3	L				Kg			
	MC - MZ	PC - PZ	HC - HZ	FP - FZ	MC - MZ	PC - PZ	HC - HZ	FP - FZ
	270	330	315	270	43	51	45	41

3/V 03L3	P71	P80	P90	S1 - M1S			S1 - M1L			S2 - M2S		
	P	P	P	L1	L1f	Y	L1	L1f	Y	L1	L1f	Y
	160	200	200	265	328	138	289	350	138	317	393	156

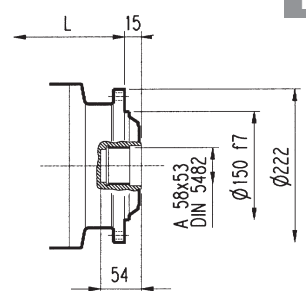
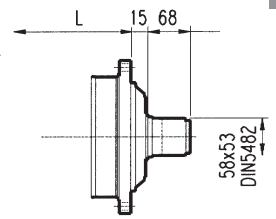
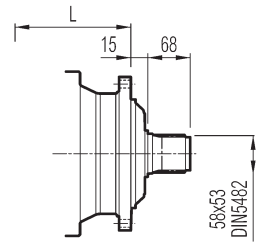
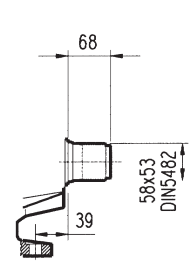
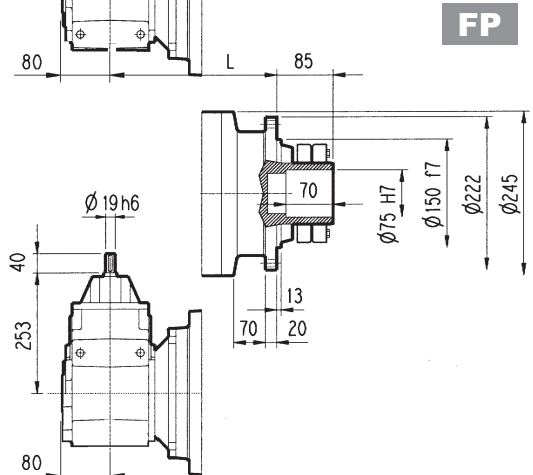
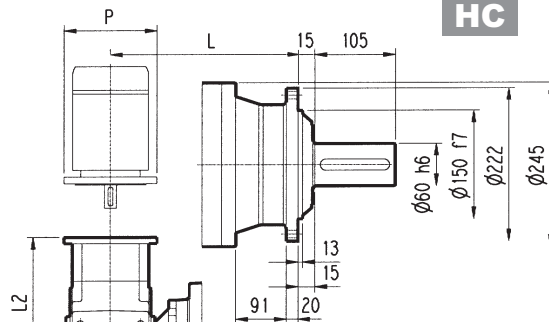
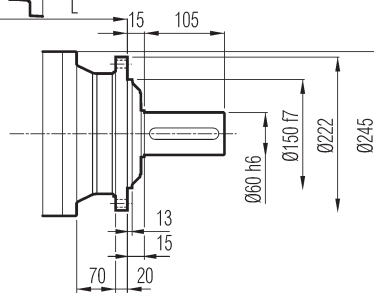
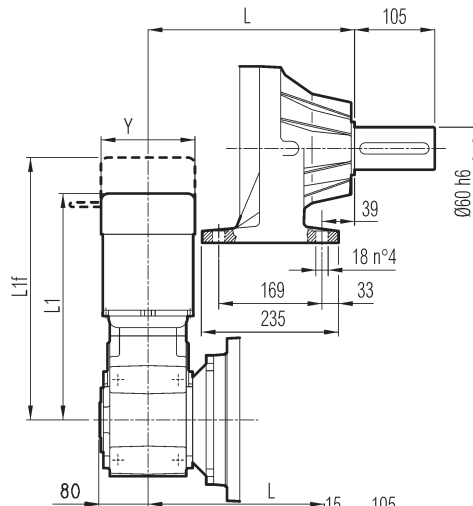
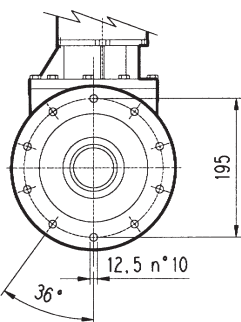
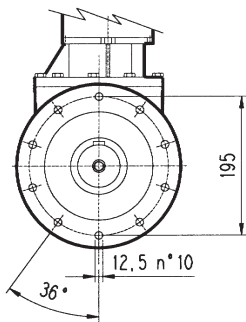
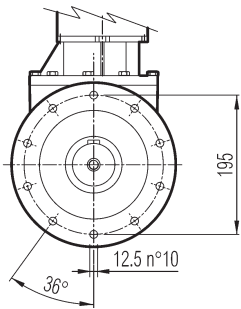
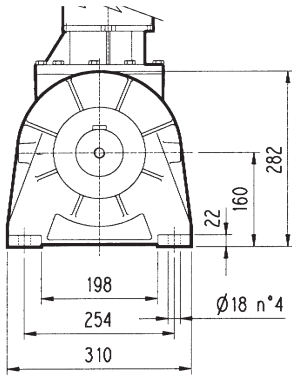
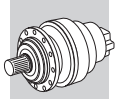

PC

PZ

MC

MZ

HC

HZ

FP

FZ

FP

$M_{2max} = 3\,500\text{ Nm}$

3/A 03L2	L				Kg			
	MC - MZ		PC - PZ		HC - HZ		FP - FZ	
	225	285	270	225	63	71	65	60

3/A 03L2	P63		P71		P80		P90		P100		P112		S1 - M1S			S1 - M1L			S2 - M2S			S3 - M3SA			S3 - M3LA		
	L2	P	L2	P	L2	P	L2	P	L2	P	L2	P	L1	L1f	Y	L1	L1f	Y	L1	L1f	Y	L1	L1f	Y	L1	L1f	Y
	243	140	243	160	262	200	262	200	272	250	272	250	371	437	138	399	416	138	425	497	156	470	467	195	501	518	195

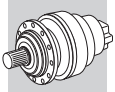

303 L

303 R

3/V 03L3

3/A 03L2

MC HC

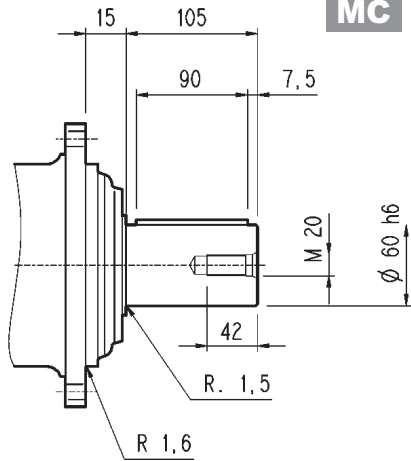

A 18x11x90
UNI 6604
DIN 6885

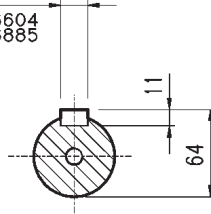

PC

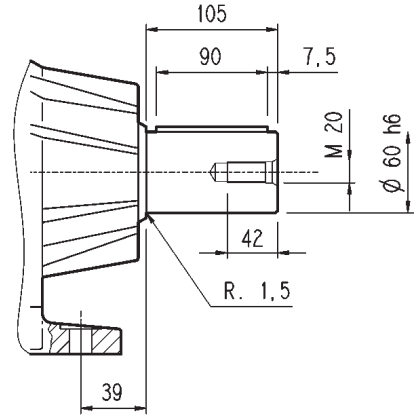

MZ HZ

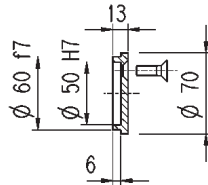
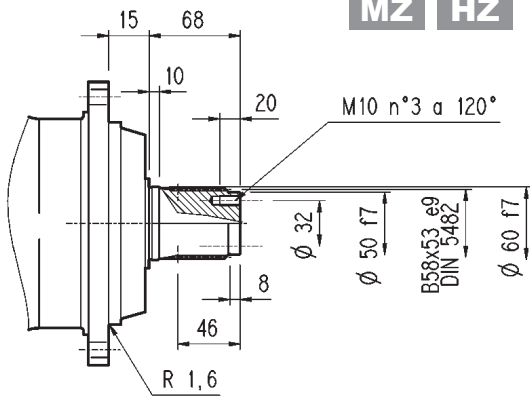

FZ

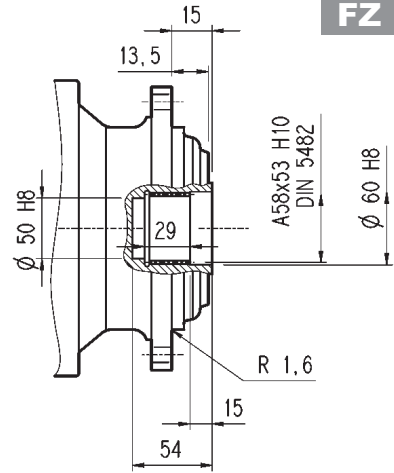

FP

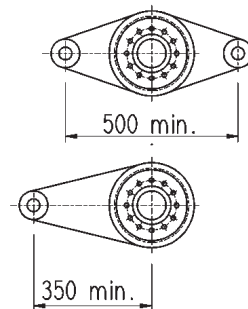
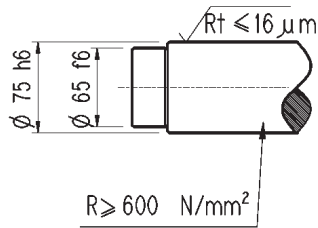
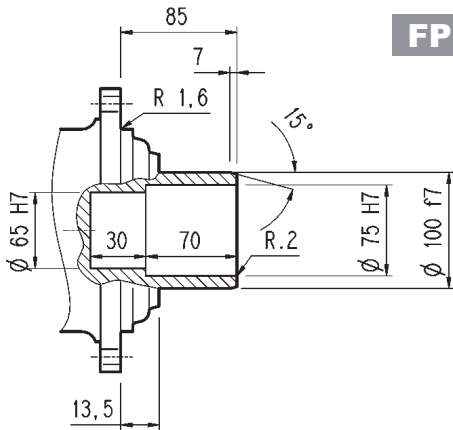

FP

$M_{2max} = 3\ 500\ Nm$

303 L

303 R

3/V 03L3

3/A 03L2

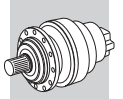

Flangia / Flange
Flansch / Brides

W0A

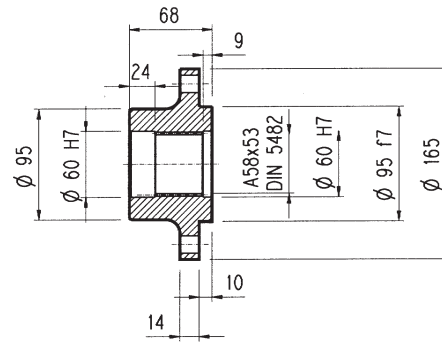
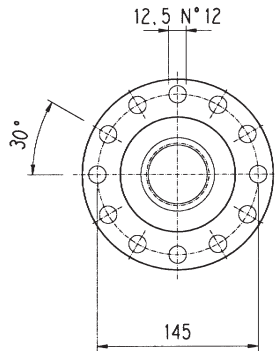
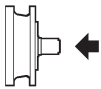

Materiale : Acciaio C40
Material : Steel C40
Material : Stahl C40
Materiał : Acier C40

Pignoni / Pinion gears
Ritzel / Pignons

P...

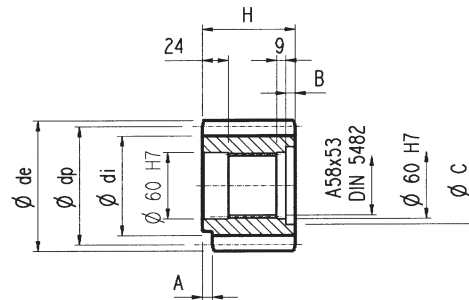
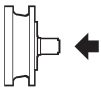

	m	z	x	dp	di	de	H	A	B	C	☆
PCL1	5	19	0	95	82	104	77	12	9	72	□
PCL2	5	19	0	95	82	104	68	0	0	0	□
PCM	5	20	0	100	87.5	110	68	18	0	0	■
PCP	5	22	0	110	97.5	120	68	18	0	0	■
PDE	6	14	0.500	84	75	99.6	68	0	0	0	□
PDI	6	18	0.500	108	99	123.6	68	0	0	0	□
PDM	6	20	0.833	120	115	140	68	0	0	0	□
PDF	8	13	0.675	104	95	127.6	68	0	0	0	■
PFE1	8	14	0	112	92	126	68	0	0	0	■
PFE2	8	14	0	112	92	126	80	0	12	72	■
PFF	8	15	0	120	100	136	68	0	0	0	□
PFP	8	22	0	176	156	190	77	12	10	71	□
PHG	10	16	0.500	160	145	188	75	0	7	72	□

☆	Materiale / Material / Material / Matriel
□	Acciaio 39NiCrMo3 Bonificato Steel 39NiCrMo3 hardened and tempered Vergüteter Stahl 39NiCrMo3 Acier bonifié 39NiCrMo3
■	Acciaio 18NiCrMo5 Cementato e temprato Steel 18NiCrMo5 Case hardened Einsatzstahl 18NiCrMo5 Einsatzgehärtet Acier cementé et tempré 18NiCrMo5

Manicotti lisci / Sleeve couplings
Naben / Manchons lisses a cannelure interieure

MOA

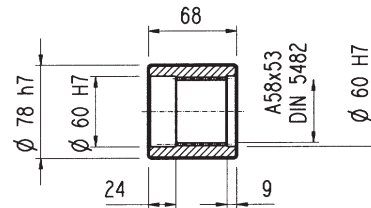
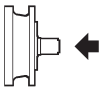

Materiale : Acciaio 16CrNi4
Material : Steel 16CrNi4
Material : Stahl 16CrNi4
Materiał : Acier 16CrNi4

Barre scanalate / Splined bars
Vielkeilwellen / Barre cannelée

B0A

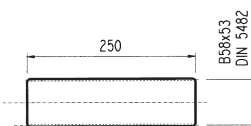
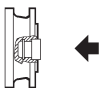

Mat. acciaio 18NiCrMo5 UNI 5331 da cementare e temprare 50-55 HRC
Case hardening steel 18NiCrMo5 UNI 5331 must be case hardened 50-55 HRC
Material: Einsatzstahl 18NiCrMo5 UNI 5331 muss einsatzgehärtet werden 50-55 HRC
Acier 18 NiCrMo5 UNI 5331 doit être cémenté trempé 50-55 HRC

Giunto ad attrito / Shrink disc
Schrumpfscheibe / Frette de serrage

G0A

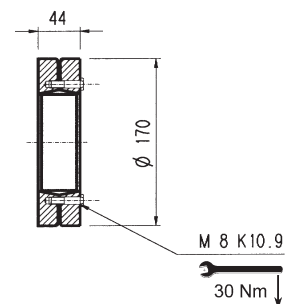
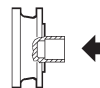

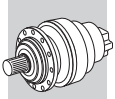

303 L

303 R

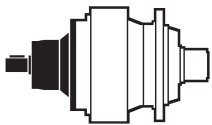
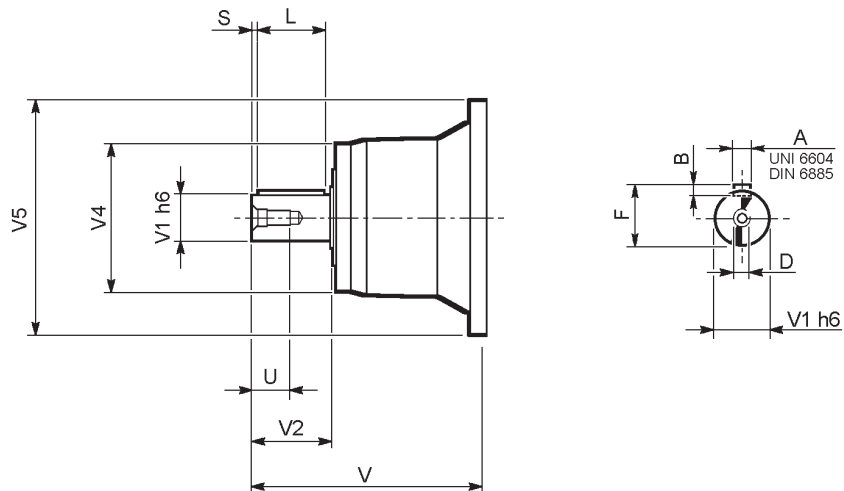

	CODE	V	V1	V2	V4	V5	A	B	F	L	S	D	U
303 L1	V05B	239	48	82	155	245	14	9	51.5	70	6	M16	36
303 L2	V01A	137.5	24	36	120	186	8	7	27	30	3	M8	19
	V01B	158	38	58	120	186	10	8	41	50	4	M12	28
303 L3	V01A	137.5	24	36	120	186	8	7	27	30	3	M8	19
	V01B	158	38	58	120	186	10	8	41	50	4	M12	28
303 L4	V01A	137.5	24	36	120	186	8	7	27	30	3	M8	19
	V01B	158	38	58	120	186	10	8	41	50	4	M12	28
303 R2-R3-R4	V01A	137.5	24	36	120	186	8	7	27	30	3	M8	19
	V01B	158	38	58	120	186	10	8	41	50	4	M12	28

3/V 03L3

3/A 03L2

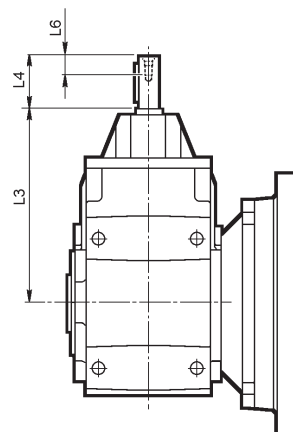
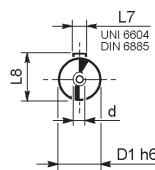
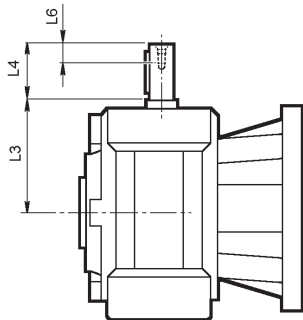
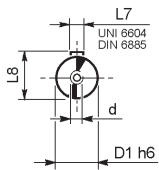

	D1 h6	L3	L4	L6	L7	L8	d
3/V 03L3_HS	18	110.5	40	16	6	20.5	M6

	D1 h6	L3	L4	L6	L7	L8	d
3/A 03L2_HS	19	252.5	40	16	6	21.5	M6

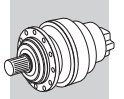

Fattore di posizione per carichi radiali sugli alberi in uscita.

Load location factor for radial loading on output shaft.

Positionsfaktor für Radialkräfte an der Abtriebswelle.

Facteur de position pour charges radiales sur les arbres en sortie.

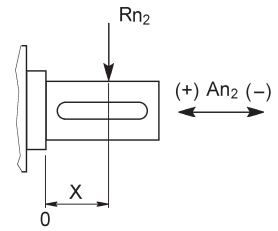
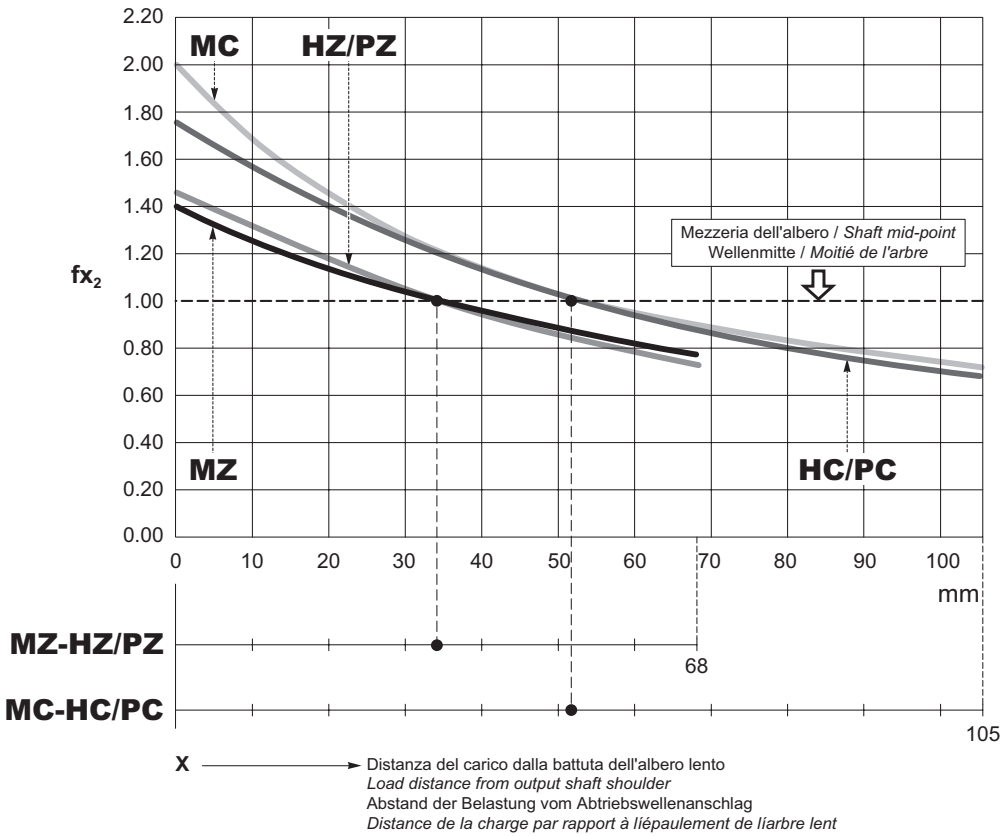

$$R_{x2} = R_{n2} \cdot f_{x2}$$

$An_2 (\pm) = R_{n2} \cdot fa_2 (\pm)$		
	$fa_2 (+)$	$fa_2 (-)$
HZ/PZ	0.74	0.59
HC/PC	0.86	0.69
MC	2.04	2.04
MZ	1.74	1.74

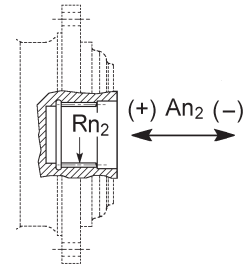

$An_2 (\pm) = R_{n2} \cdot fa_2 (\pm)$		
	$fa_2 (+)$	$fa_2 (-)$
FZ	1.00	1.00

Carichi radiali ammissibili sull'albero veloce per $n_1 = 1000 \text{ min}^{-1}$ e 10000 h di vita teorica.

Permitted overhung loads on input shaft when $n_1 = 1000 \text{ min}^{-1}$ and theoretical lifetime = 10000 h.

Zulässige Radialkräfte an den Antriebswellen für $n_1 = 1000 \text{ min}^{-1}$ und 10000 std.

Charges radiales admissibles sur les arbres d'entrée pour $n_1 = 1000 \text{ min}^{-1}$ et 10000 h.

Per velocità di comando e/o durate diverse vedi il capitolo: Verifiche.

For drive speed and/or lifetimes other than those specified here, see Chapter: Verifications.

Im Hinblick auf Geschwindigkeit und/oder anderweitige Dauern verweisen wir auf Par: Prüfungen

Pour des vitesses et/ou durées différentes, voir par. Vérifications.

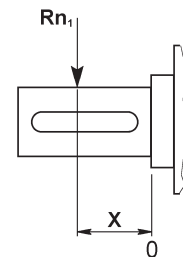
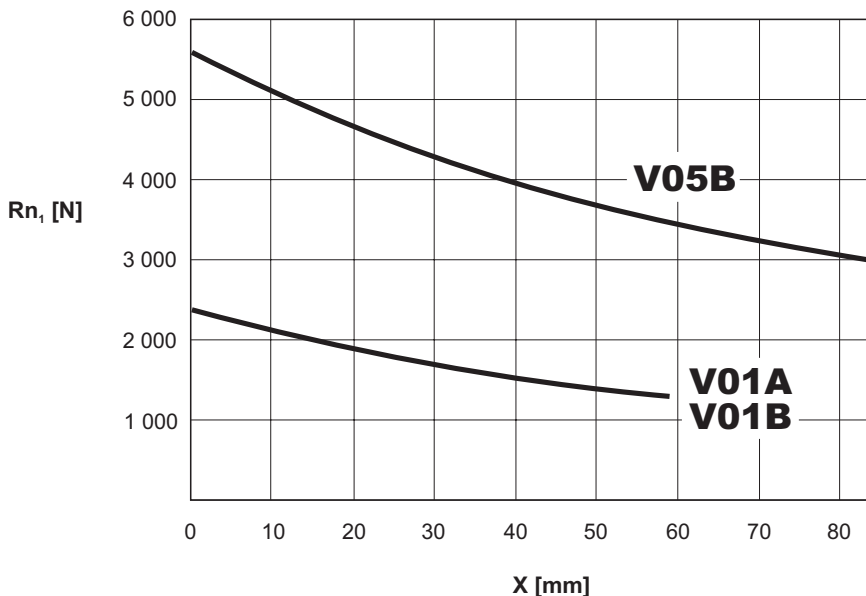

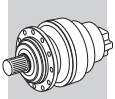

303_VK

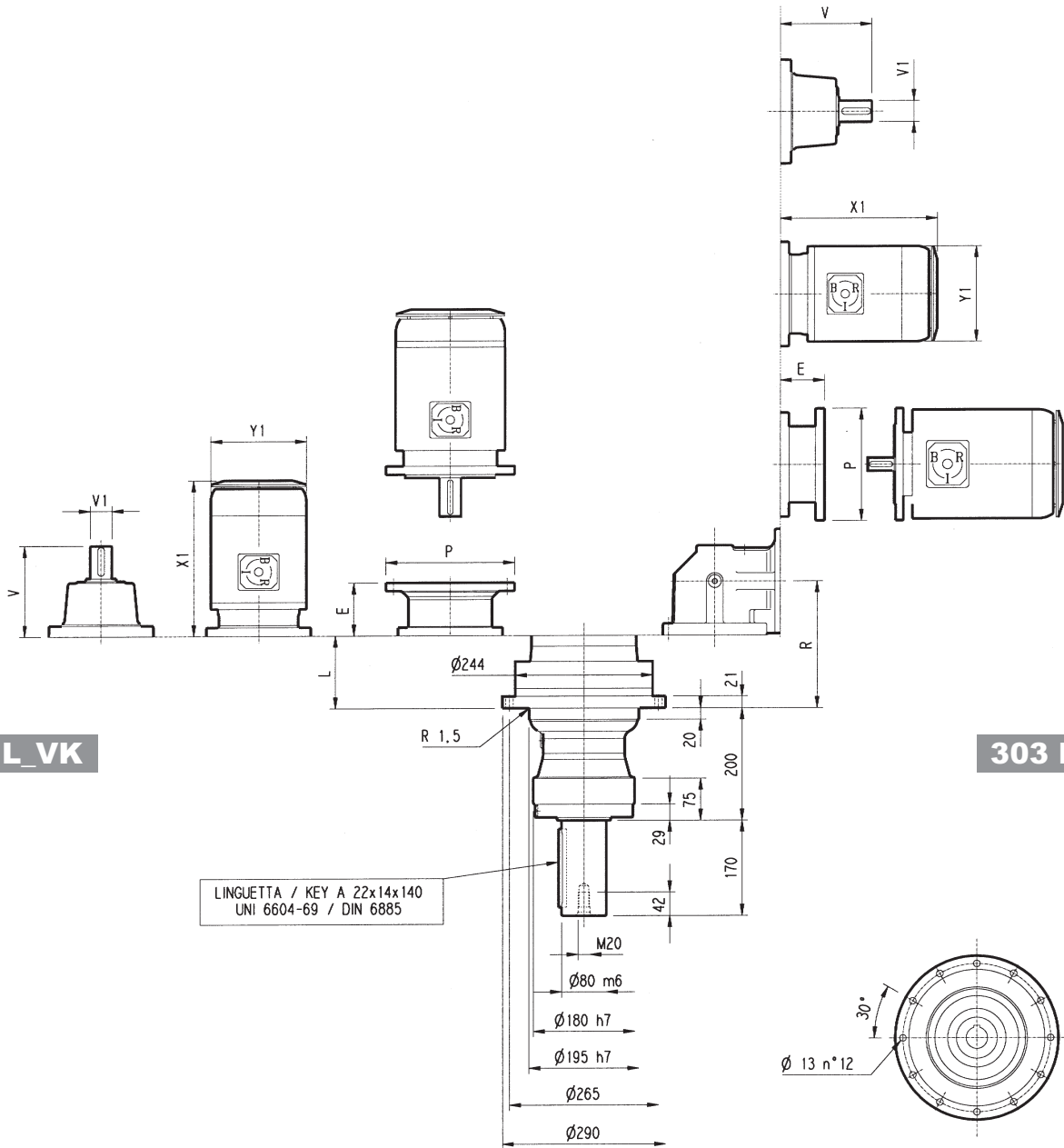

303 L_VK

303 R_VK

	L	Kg	Albero veloce / Input shaft Antriebswelle / Arbre d'entrée						P71		P80		P90		P100		P112		P132		P160		P180	
			V	V1	Kg	V	V1	Kg	E	P	E	P	E	P	E	P	E	P	E	P	E	P	E	P
303 L1	51	65	239	48	15	-	-	-	-	-	-	-	-	-	-	-	-	-	114	300	144	350	144	350
303 L2	104	70	137.5	24	6	158	38	7	65	160	84	200	84	200	94	250	94	250	114	300	-	-	-	-
303 L3	157	73	137.5	24	6	158	38	7	65	160	84	200	84	200	94	250	94	250	114	300	-	-	-	-
303 L4	210	77	137.5	24	6	158	38	7	65	160	84	200	84	200	94	250	94	250	114	300	-	-	-	-

	R	R1	Kg	Albero veloce / Input shaft Antriebswelle / Arbre d'entrée						P71		P80		P90		P100		P112		P132	
				V	V1	Kg	V	V1	Kg	E	P	E	P	E	P	E	P	E	P	E	P
303 R2	143	140	85	137.5	24	6	158	38	7	65	160	84	200	84	200	94	250	94	250	114	300
303 R3	196	122	83	137.5	24	6	158	38	7	65	160	84	200	84	200	94	250	94	250	-	-
303 R4	249	122	87	137.5	24	6	158	38	7	65	160	84	200	84	200	94	250	94	250	-	-

	S1 - M1S			S1 - M1L			S2 - M2S			S3 - M3S			S3 - M3L			S4 - M4			S5 - M5S			S5 - M5L		
	X1	X2	Y1	X1	X2	Y1	X1	X2	Y1	X1	X2	Y1	X1	X2	Y1	X1	X2	Y1	X1	X2	Y1	X1	X2	Y1
303 L1	-	-	-	-	-	-	-	-	-	-	-	-	-	-	-	460	571	258	552	692	310	596	736	310
303 L2	229	292	138	253	314	138	280	352	156	325	421	195	357	449	195	460	571	258	-	-	-	-	-	-
303 L3	229	292	138	253	314	138	280	352	156	325	421	195	357	449	195	460	571	258	-	-	-	-	-	-
303 L4	229	292	138	253	314	138	280	352	156	325	421	195	357	449	195	460	571	258	-	-	-	-	-	-

	S1 - M1S			S1 - M1L			S2 - M2S			S3 - M3S			S3 - M3L			S4 - M4		
	X1	X2	Y1	X1	X2	Y1	X1	X2	Y1	X1	X2	Y1	X1	X2	Y1	X1	X2	Y1
303 R2	-	-	-	-	-	-	328	400	156	373	469	195	405	497	195	508	619	258
303 R3	229	292	138	253	314	138	328	400	156	373	469	195	405	497	195	-	-	-
303 R4	229	292	138	253	314	138	328	400	156	373	469	195	405	497	195	-	-	-

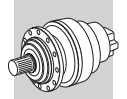

Il diagramma seguente consente di ricavare il carico radiale ammissibile R_{x2} quando questo è applicato alla distanza x dallo spallamento dell'albero lento del riduttore 303_VK.

Le curve si riferiscono al valore risultante dal rapporto fra il carico assiale A_{n2} e il carico radiale R_{n2} , entrambi riferiti a $n_2 = 10 \text{ min}^{-1}$ e durata teorica di 10000 h.

The diagram below allows the calculation of permitted overhung load R_{x2} on the output shaft of gearbox type 303_VK, with radial force applying at a distance x from shaft shoulder.

The curves are relevant to value resulting from the relationship of trust load A_{n2} to radial load R_{n2} , based on $n_2 = 10 \text{ min}^{-1}$ and 10000 hrs theoretical lifetime.

Das nachstehende Diagramm ermöglicht das Individuieren der zulässigen, auf die Welle des Getriebes 303_VK einwirkenden Radialkraft, die auf der Distanz x vom Anschlag der Welle selbst appliziert wird.

Die Kurven beziehen sich auf den Wert, der sich aus dem Verhältnis zwischen der Axialkraft A_{n2} und der Radialkraft R_{n2} für $n_2 = 10 \text{ min}^{-1}$ und einer Dauer von 10000 Std. ergibt.

Le diagramme suivant permet de déterminer la charge radiale admissible R_{x2} sur l'arbre lent du réducteur 303_VK appliqué à la distance x de l'épaule de l'arbre.

Les courbes se réfèrent à la valeur résultant de l'équation entre la charge axiale A_{n2} et la charge radiale R_{n2} pour $n_2 = 10 \text{ min}^{-1}$ et durée de 10000 h.

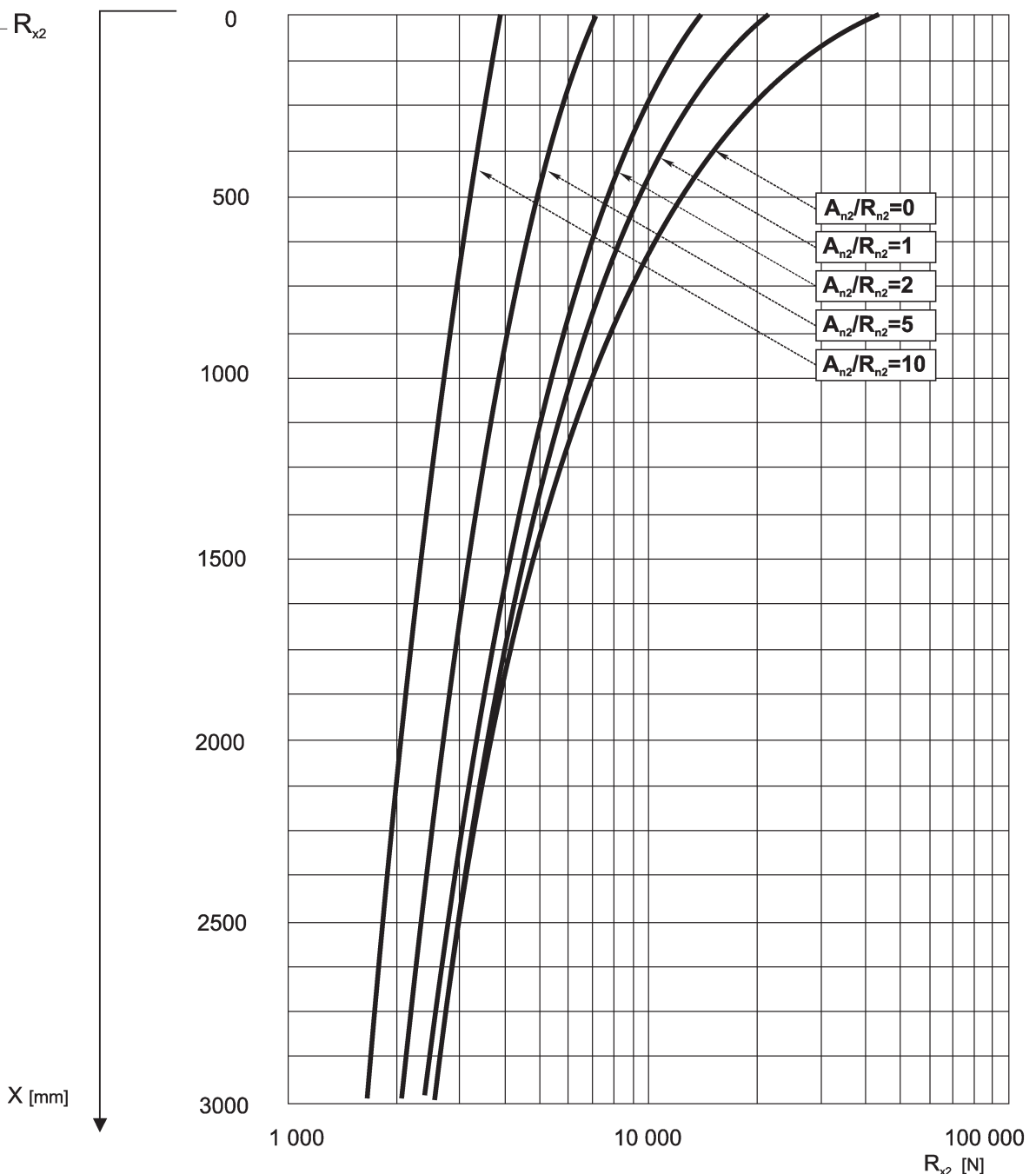
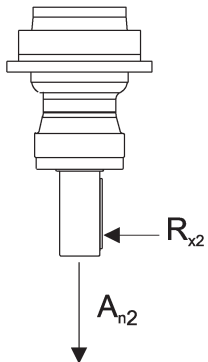

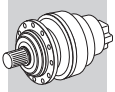

305 L

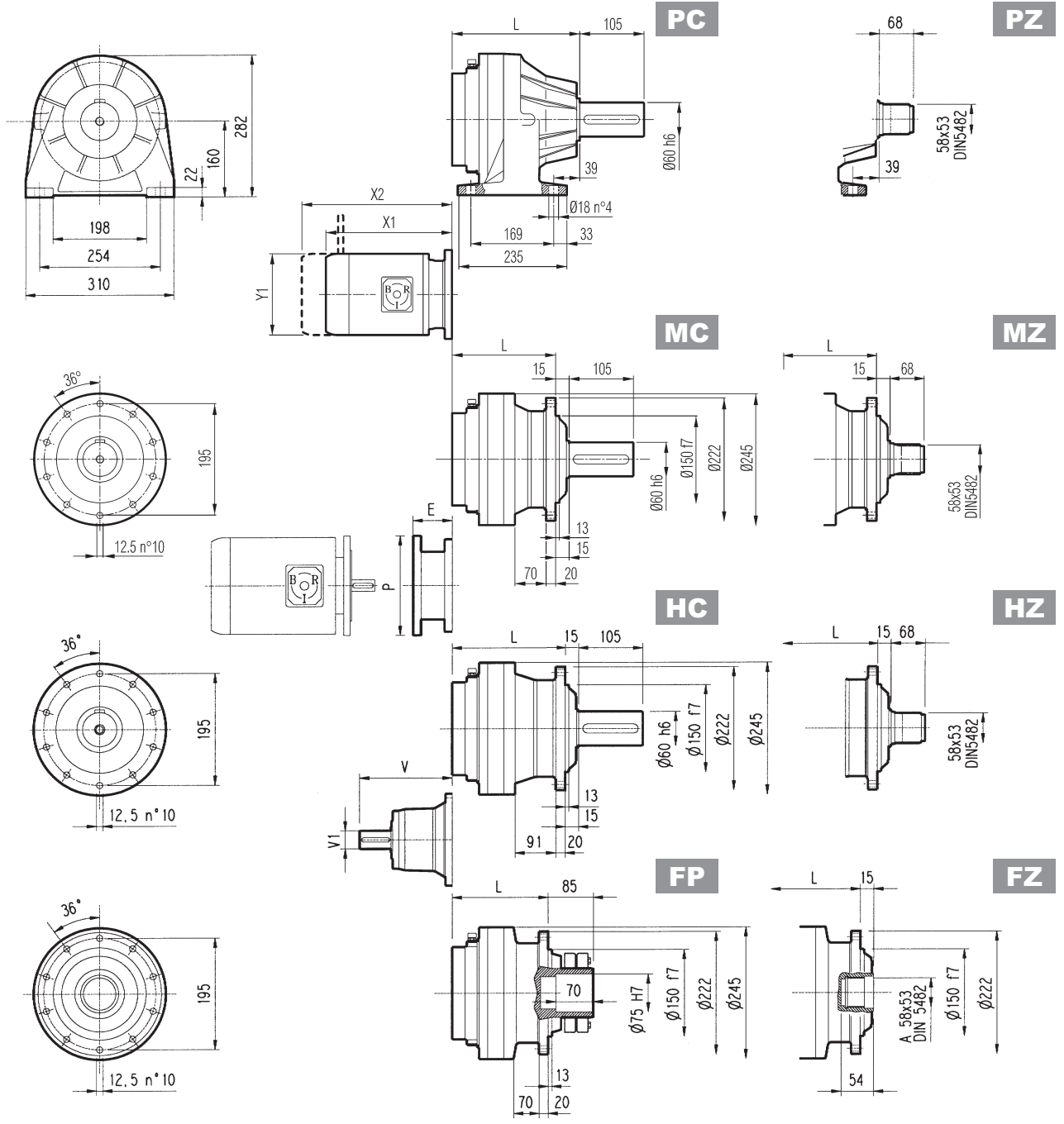

FP $M_{2max} = 7\ 000\ Nm$

	L				Kg				Albero veloce / Input shaft / Antriebswelle / Arbre d'entrée					
	MC - MZ	PC - PZ	HC - HZ	FP - FZ	MC - MZ	PC - PZ	HC - HZ	FP - FZ	V	V1	Kg	V	V1	Kg
305 L1	143	183	168	143	36	45	40	36	239	48	15	-	-	-
305 L2	208	248	233	208	43	52	47	43	137.5	24	6	158	38	7
305 L3	261	301	286	261	47	56	51	47	137.5	24	6	158	38	7
305 L4	314	354	339	314	51	60	55	51	137.5	24	6	158	38	7

	P71		P80		P90		P100		P112		P132		P160		P180	
	E	P	E	P	E	P	E	P	E	P	E	P	E	P	E	P
305 L1	-	-	-	-	-	-	-	-	-	-	114	300	144	350	144	350
305 L2	65	160	84	200	84	200	94	250	94	250	114	300	-	-	-	-
305 L3	65	160	84	200	84	200	94	250	94	250	114	300	-	-	-	-
305 L4	65	160	84	200	84	200	94	250	94	250	114	300	-	-	-	-

	S1 - M1S			S1 - M1L			S2 - M2S			S3 - M3S			S3 - M3L			S4 - M4			S5 - M5S			S5 - M5L		
	X1	X2	Y1	X1	X2	Y1	X1	X2	Y1	X1	X2	Y1	X1	X2	Y1	X1	X2	Y1	X1	X2	Y1	X1	X2	Y1
305 L1	-	-	-	-	-	-	-	-	-	-	-	-	-	-	-	460	571	258	552	692	310	596	736	310
305 L2	-	-	-	-	-	-	280	352	156	325	421	195	357	449	195	460	571	258	-	-	-	-	-	-
305 L3	229	292	138	253	314	138	280	352	156	325	421	195	357	449	195	460	571	258	-	-	-	-	-	-
305 L4	229	292	138	253	314	138	280	352	156	325	421	195	357	449	195	460	571	258	-	-	-	-	-	-

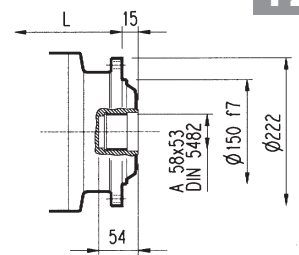
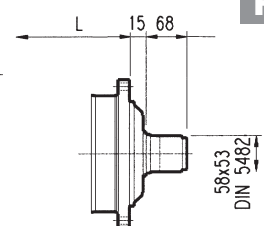
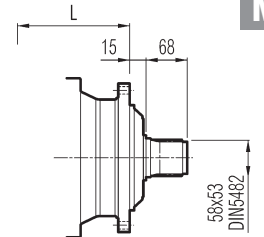
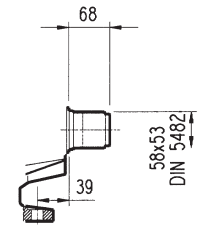
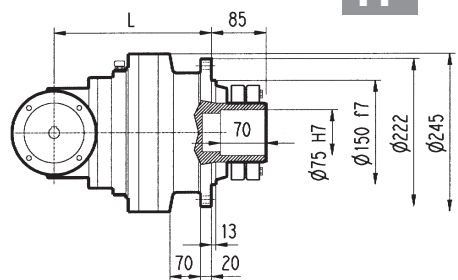
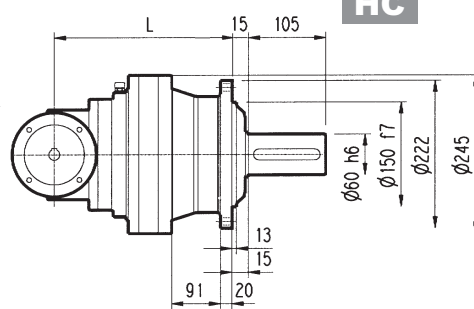
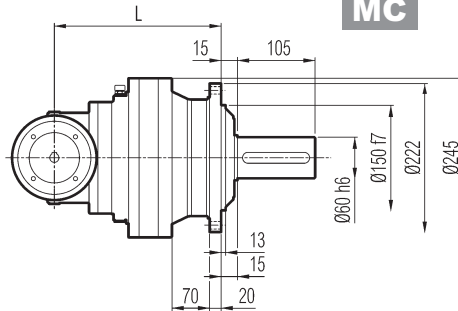
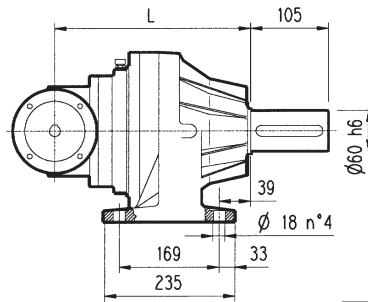
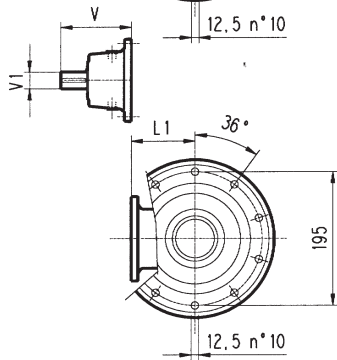
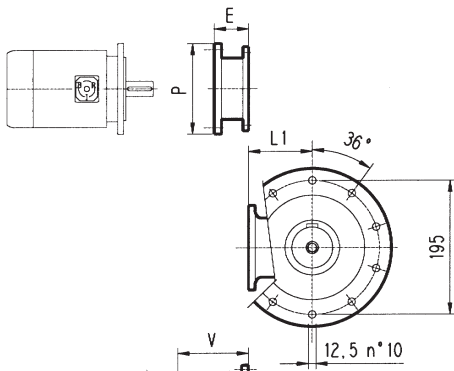
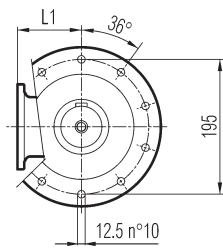
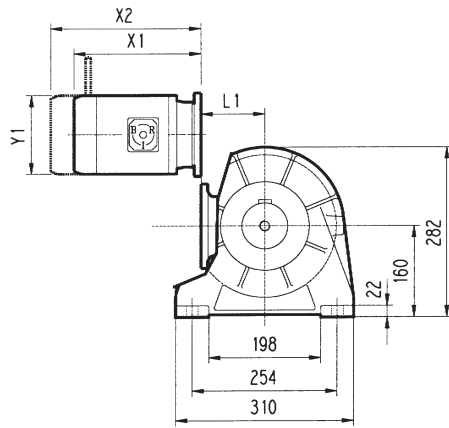
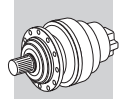

PC

PZ

MC

MZ

HC

HZ

FP

FZ

FP

$M_{2max} = 7\ 000\ Nm$

	L				L1	Kg				Albero veloce / Input shaft / Antriebswelle / Arbre d'entrée					
	MC - MZ	PC - PZ	HC - HZ	FP - FZ		MC - MZ	PC - PZ	HC - HZ	FP - FZ	V	V1	Kg	V	V1	Kg
305 R2	235	375	260	235	140	56	65	60	56	137.5	24	6	158	38	7
305 R3	300	340	325	300	122	57	66	61	57	137.5	24	6	158	38	7
305 R4	353	393	378	353	122	61	70	65	61	137.5	24	6	158	38	7

	P71		P80		P90		P100		P112		P132	
	E	P	E	P	E	P	E	P	E	P	E	P
305 R2	65	160	84	200	84	200	94	250	94	250	114	300
305 R3	65	160	84	200	84	200	94	250	94	250	114	300
305 R4	65	160	84	200	84	200	94	250	94	250	114	300

	S1 - M1S			S1 - M1L			S2 - M2S			S3 - M3S			S3 - M3L			S4 - M4		
	X1	X2	Y1	X1	X2	Y1	X1	X2	Y1	X1	X2	Y1	X1	X2	Y1	X1	X2	Y1
305 R2	-	-	-	-	-	-	328	400	156	373	469	195	405	497	195	508	619	258
305 R3	229	292	138	253	314	138	328	400	156	373	469	195	405	497	195	508	619	258
305 R4	229	292	138	253	314	138	328	400	156	373	469	195	405	497	195	508	619	258

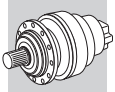

3/V 05L3

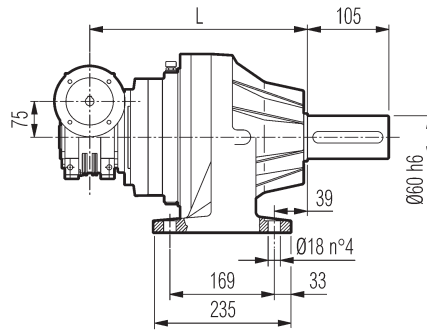
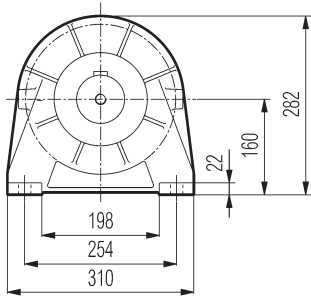

PC

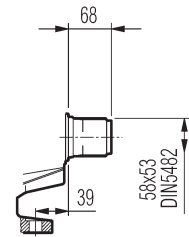

PZ

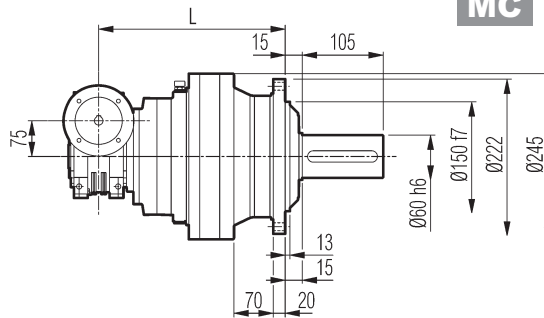
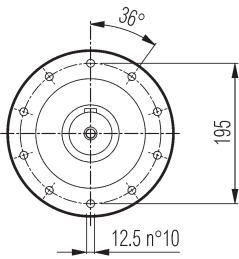

MC

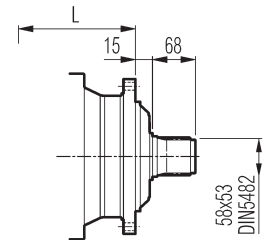

MZ

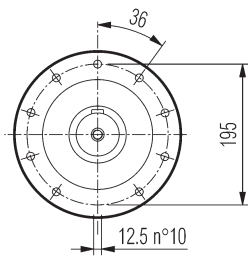

A

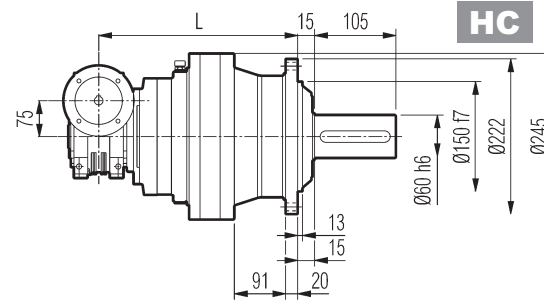

HC

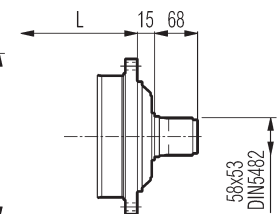

HZ

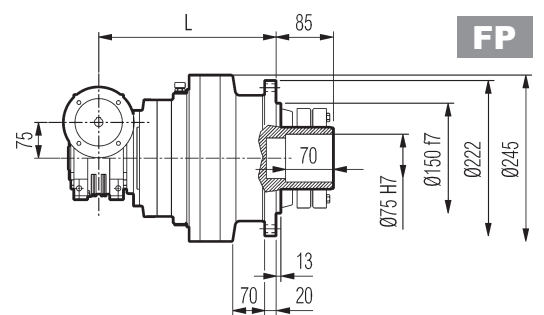
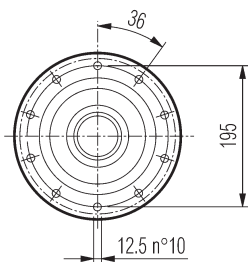

FP

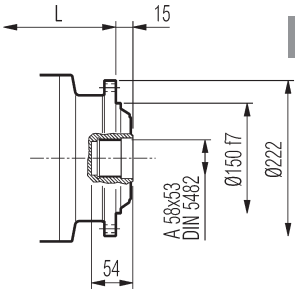

FZ

VISTA DA A
VIEW FROM A

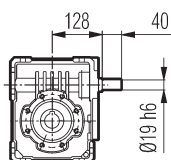

112 : P71-P80-P90
120 : P100-P112

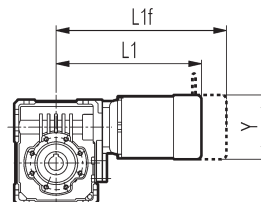
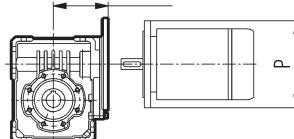

FP

$M_{2max} = 7\,000\text{ Nm}$

	L				Kg				P71	P80	P90	P100
	MC - MZ	PC - PZ	HC - HZ	FP - FZ	MC - MZ	PC - PZ	HC - HZ	FP - FZ	P	P	P	P
3/V 05L3	323	363	348	323	51	60	55	51	160	200	200	250

	S1 - M1S			S1 - M1L			S2 - M2S			S3 - M3S			S3 - M3L		
	L1	L1f	Y	L1	L1f	Y	L1	L1f	Y	L1	L1f	Y	L1	L1f	Y
3/V 05L3	284	347	138	308	369	138	333	409	156	376	472	193	408	499	193

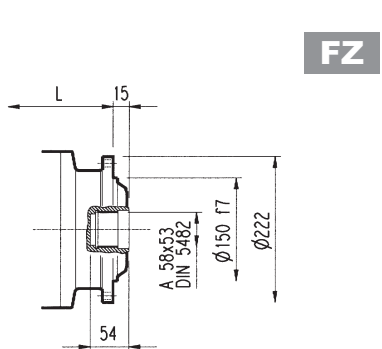
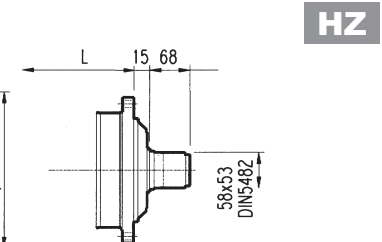
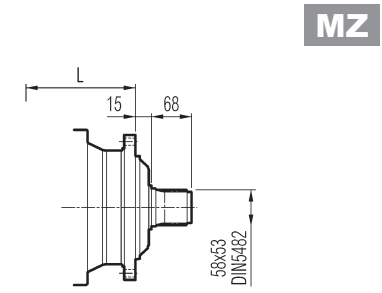
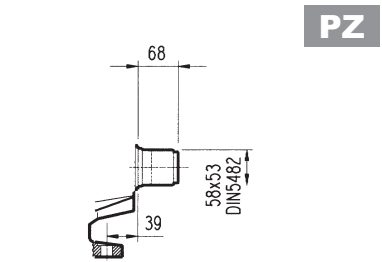
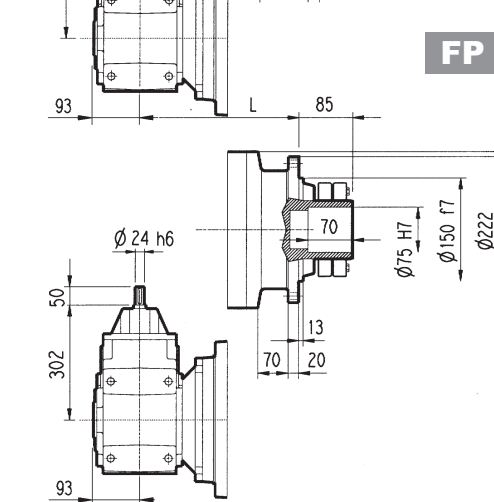
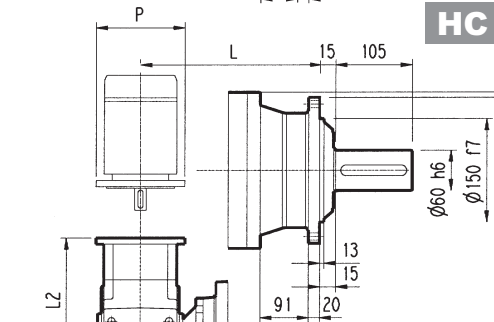
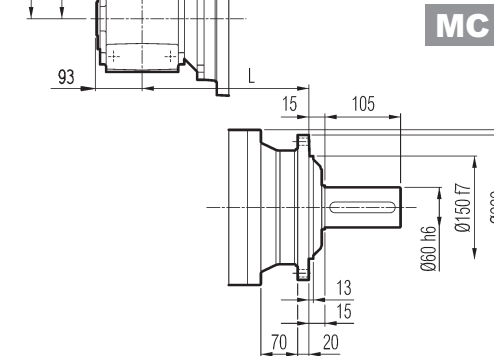
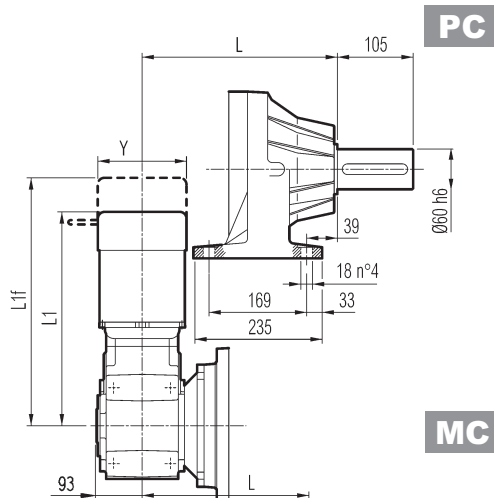
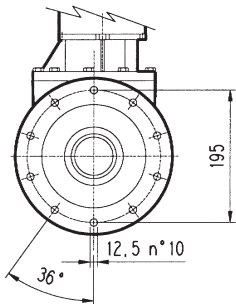
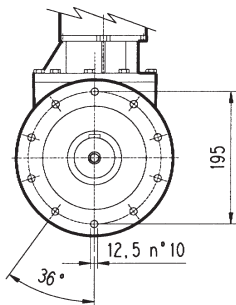
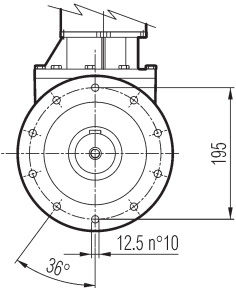
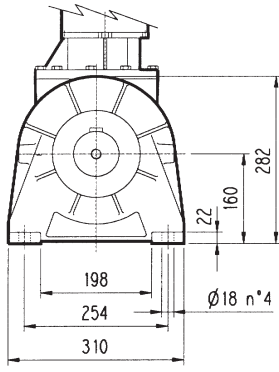
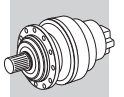

FP $M_{2max} = 7\ 000\ Nm$

	L								kg	D1	L3	L4
	MC - MZ	PC - PZ	HC - HZ	FP - FZ	MC - MZ	PC - PZ	HC - HZ	FP - FZ				
3/A 05L2	276	316	301	276	90	105	100	90	24	302	50	

	P63		P71		P80		P90		P100		P112		P132	
	L2	P	L2	P	L2	P	L2	P	L2	P	L2	P	L2	P
3/A 05L2	263	140	263	160	282.5	200	282.5	200	292.5	250	292.5	250	329	457

	S1 - M1S			S1 - M1L			S2 - M2S			S3 - M3SA			S3 - M3LA			S4 - M4		
	L1	L1f	Y	L1	L1f	Y	L1	L1f	Y	L1	L1f	Y	L1	L1f	Y	L1	L1f	Y
3/A 05L2	394	457	138	418	439	138	447	517	156	490	487	195	522	538	195	630	738	258

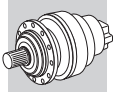

305 L

305 R

3/V 05L3

3/A 05L2

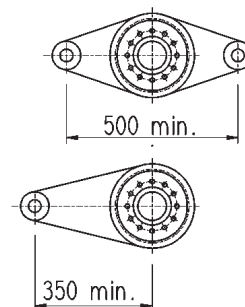
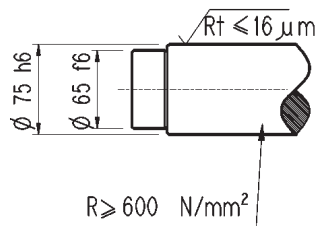
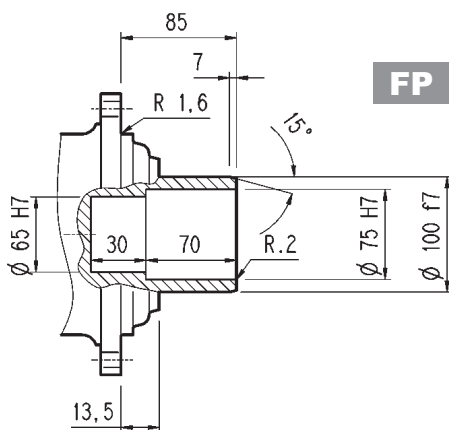
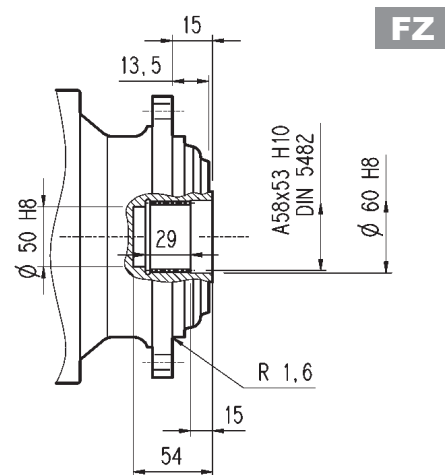
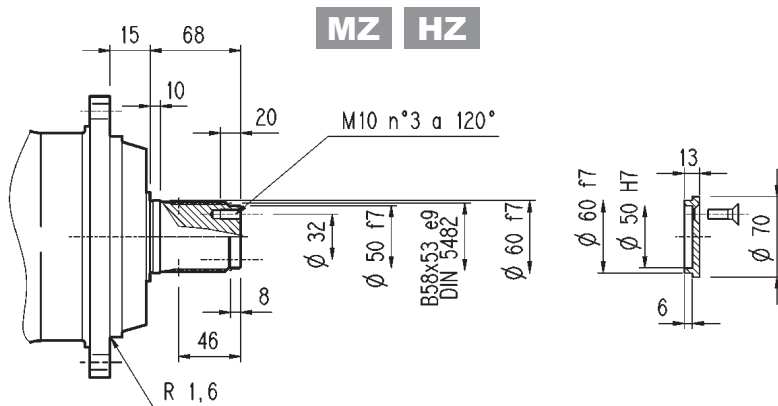
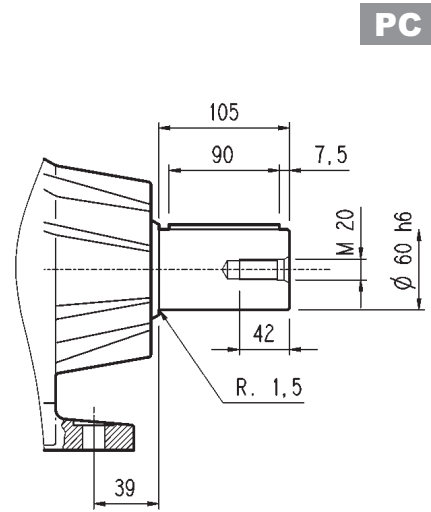
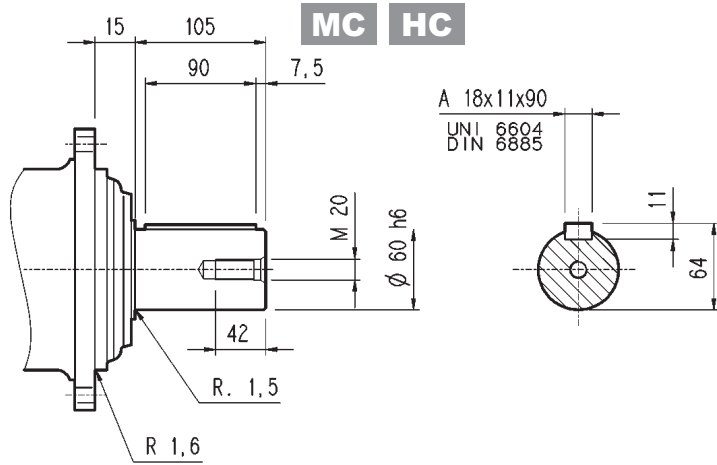

FP

$M_{2max} = 7\,000\text{ Nm}$

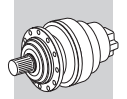
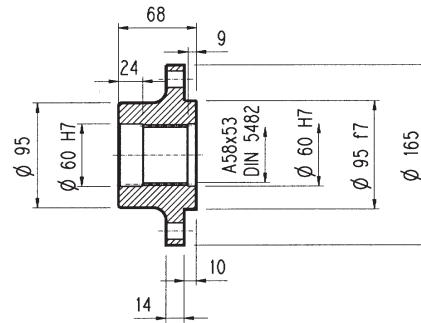
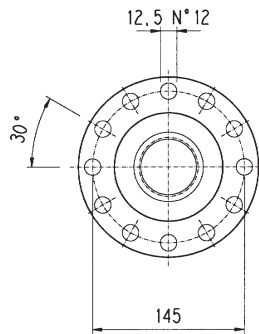
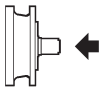
305 L**305 R****3/V 05L3****3/A 05L2**
Flangia / Flange
Flansch / Brides
WOA

Materiale : Acciaio C40
 Material : Steel C40
 Material : Stahl C40
 Matière : Acier C40

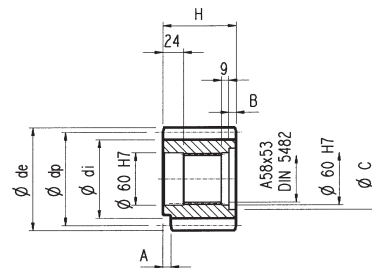
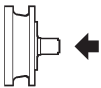
Pignoni / Pinion gears
Ritzel / Pignons
P...

	m	z	x	dp	di	de	H	A	B	C	☆
PCL1	5	19	0	95	82	104	77	12	9	72	□
PCL2	5	19	0	95	82	104	68	0	0	0	□
PCM	5	20	0	100	87.5	110	68	18	0	0	■
PCP	5	22	0	110	97.5	120	68	18	0	0	■
PDE	6	14	0.500	84	75	99.6	68	0	0	0	□
PDI	6	18	0.500	108	99	123.6	68	0	0	0	□
PDM	6	20	0.833	120	115	140	68	0	0	0	□
PFD	8	13	0.675	104	95	127.6	68	0	0	0	■
PFE1	8	14	0	112	92	126	68	0	0	0	■
PFE2	8	14	0	112	92	126	80	0	12	72	■
PFF	8	15	0	120	100	136	68	0	0	0	□
PFP	8	22	0	176	156	190	77	12	10	71	□
PHG	10	16	0.500	160	145	188	75	0	7	72	□

☆	Materiale / Material / Material / Matière
□	Acciaio 39NiCrMo3 Bonificato Steel 39NiCrMo3 hardened and tempered Vergüteter Stahl 39NiCrMo3 Acier bonifiée 39NiCrMo3
■	Acciaio 18NiCrMo5 Cementato e temprato Steel 18NiCrMo5 Case hardened Einsatzstahl 18NiCrMo5 Einsatzgehärtet Acier cémentée et tempré 18NiCrMo5

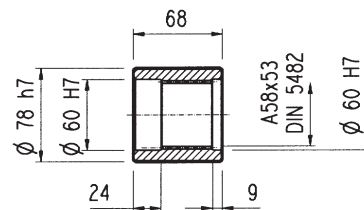
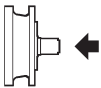
Manicotti lisci / Sleeve couplings
Naben / Manchons lisses a cannelure interieure
MOA

Materiale : Acciaio 16CrNi4
 Material : Steel 16CrNi4
 Material : Stahl 16CrNi4
 Matière : Acier 16CrNi4

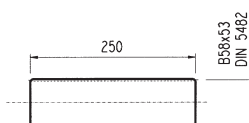
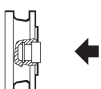
Barre scanalate / Splined bars
Vielkeilwellen / Barre cannelée
B0A

Mat. acciaio 18NiCrMo5 UNI 5331 da cementare e temprare 50-55 HRC
 Case hardening steel 18NiCrMo5 UNI 5331 must be case hardened 50-55 HRC
 Material: Einsatzstahl 18NiCrMo5 UNI 5331 muss einsatzgehärtet werden 50-55 HRC
 Acier 18 NiCrMo5 UNI 5331 doit être cémenté trempé 50-55 HRC

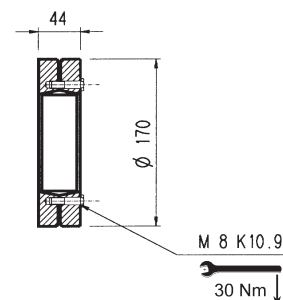
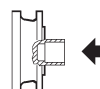
Giunto ad attrito / Shrink disc
Schrumpfscheibe / Frette de serrage
GOA

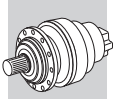

305 L

305 R

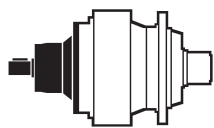
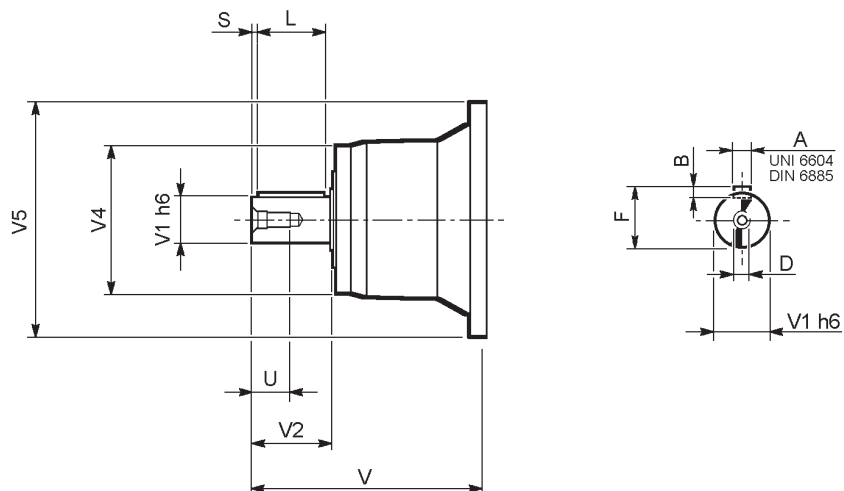

	CODE	V	V1	V2	V4	V5	A	B	F	L	S	D	U
305 L1	V05B	239	48	82	155	245	14	9	51.5	70	6	M16	36
305 L2	V01A	137.5	24	36	120	186	8	7	27	30	3	M8	19
	V01B	158	38	58	120	186	10	8	41	50	4	M12	28
305 L3	V01A	137.5	24	36	120	186	8	7	27	30	3	M8	19
	V01B	158	38	58	120	186	10	8	41	50	4	M12	28
305 L4	V01A	137.5	24	36	120	186	8	7	27	30	3	M8	19
	V01B	158	38	58	120	186	10	8	41	50	4	M12	28
305 R2-R3-R4	V01A	137.5	24	36	120	186	8	7	27	30	3	M8	19
	V01B	158	38	58	120	186	10	8	41	50	4	M12	28

3/V 05L3

3/A 05L2

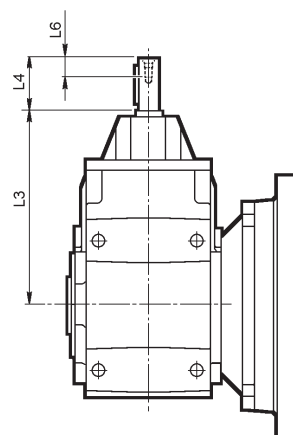
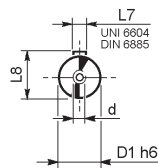
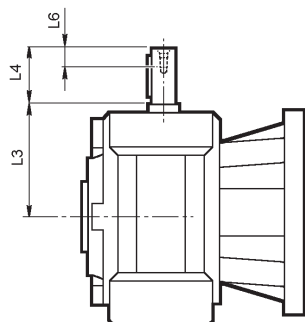
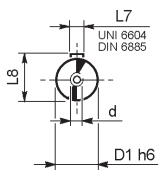

	D1 h6	L3	L4	L6	L7	L8	d
3/V 05L3_HS	19	128	40	16	6	21.5	M6

	D1 h6	L3	L4	L6	L7	L8	d
3/A 05L2_HS	24	302	50	19	8	27	M8

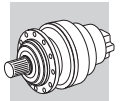

Fattore di posizione per carichi radiali sugli alberi in uscita.

Load location factor for radial loading on output shaft.

Positionsfaktor für Radialkräfte an der Abtriebswelle.

Facteur de position pour charges radiales sur les arbres en sortie.

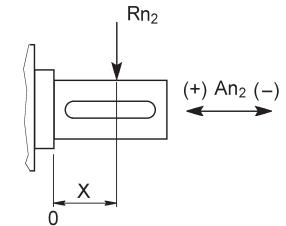
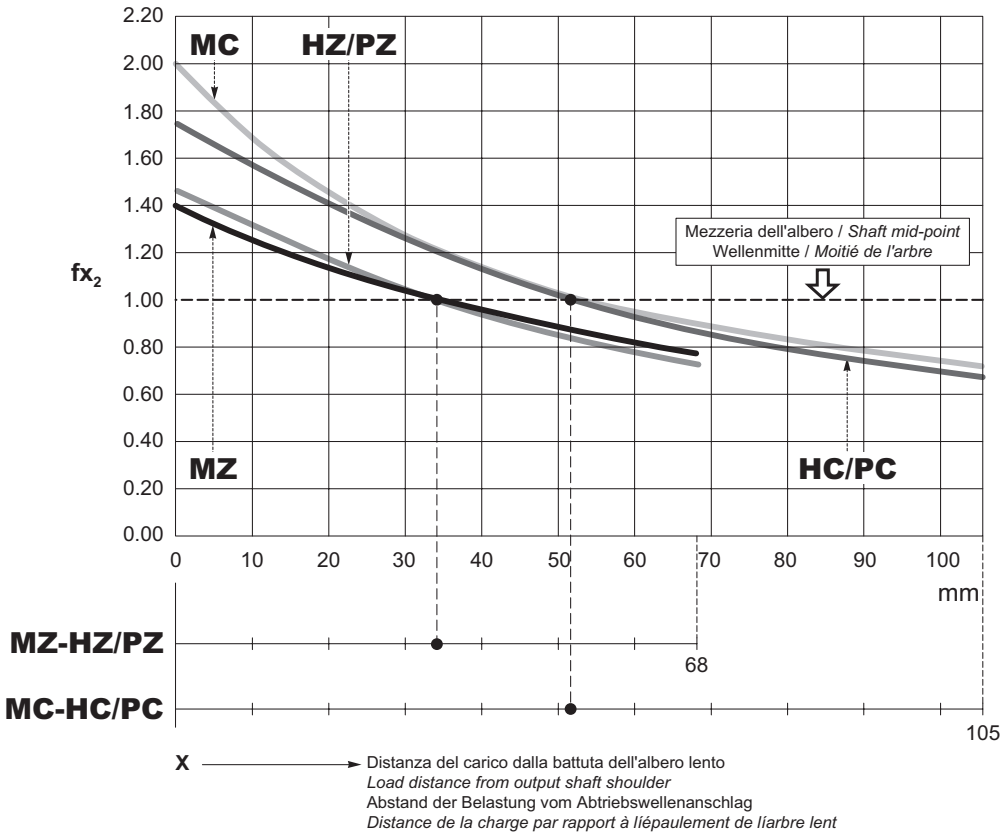

$$R_{x2} = Rn_2 \cdot fx_2$$

$An_2 (\pm) = Rn_2 \cdot fa_2 (\pm)$		
	$fa_2 (+)$	$fa_2 (-)$
HZ/PZ	0.74	0.59
HC/PC	0.86	0.69
MC	2.04	2.04
MZ	1.74	1.74

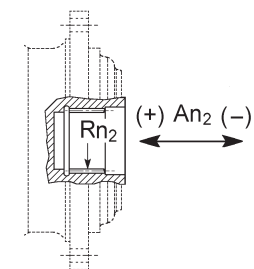

$$An_2 (\pm) = Rn_2 \cdot fa_2 (\pm)$$

	$fa_2 (+)$	$fa_2 (-)$
FZ	1.04	1.04

Carichi radiali ammissibili sull'albero veloce per $n_1 = 1000 \text{ min}^{-1}$ e 10000 h di vita teorica. Per velocità di comando e/o durate diverse vedi il capitolo: Verifiche.

Permitted overhung loads on input shaft when $n_1 = 1000 \text{ min}^{-1}$ and theoretical lifetime = 10000 h. For drive speed and/or lifetimes other than those specified here, see Chapter: Verifications.

Zulässige Radialkräfte an den Antriebswellen für $n_1 = 1000 \text{ min}^{-1}$ und 10000 std. Im Hinblick auf Geschwindigkeit und/oder anderweitige Dauern verweisen wir auf Par. Prüfungen

Charges radiales admissibles sur les arbres d'entrée pour $n_1 = 1000 \text{ min}^{-1}$ et 10000 h. Pour des vitesses et/ou durées différentes, voir par. Vérifications.

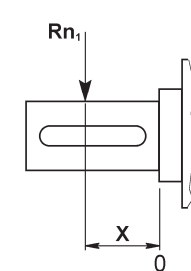
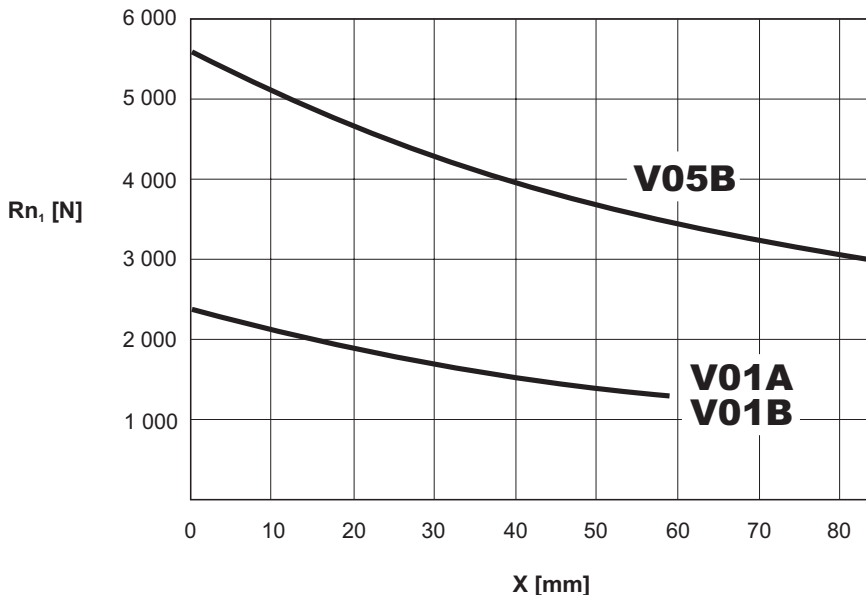

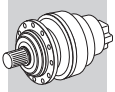

305_VK

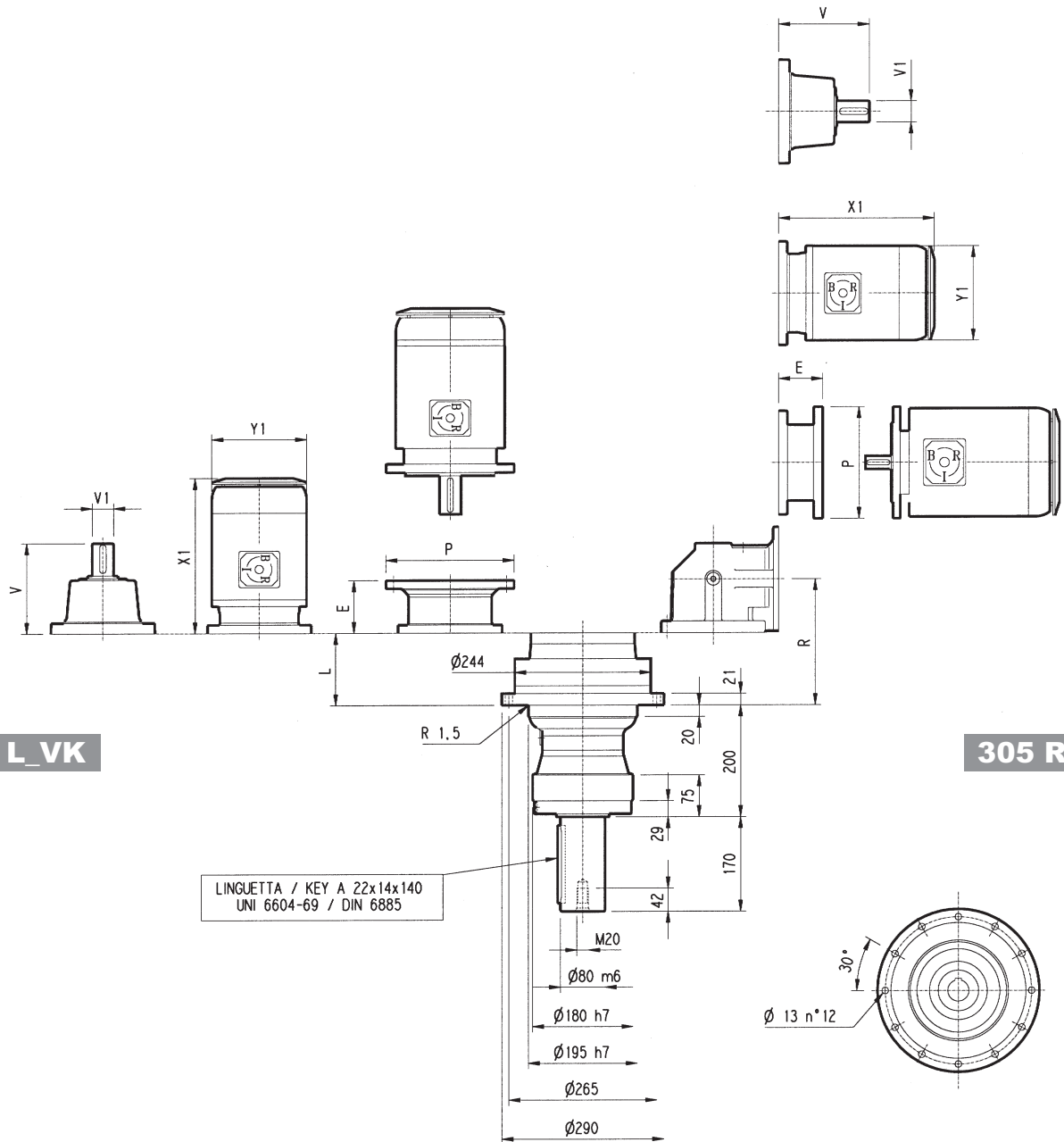

305 L_VK

305 R_VK

	L	Kg	Albero veloce / Input shaft Antriebswelle / Arbre d'entrée						P71		P80		P90		P100		P112		P132		P160		P180	
			V	V1	Kg	V	V1	Kg	E	P	E	P	E	P	E	P	E	P	E	P	E	P	E	P
305 L1	69	70	239	48	15	-	-	-	65	160	84	200	84	200	94	250	94	250	114	300	144	350	144	350
305 L2	134	77	137.5	24	6	158	38	7	65	160	84	200	84	200	94	250	94	250	114	300	-	-	-	-
305 L3	187	81	137.5	24	6	158	38	7	65	160	84	200	84	200	94	250	94	250	114	300	-	-	-	-
305 L4	240	85	137.5	24	6	158	38	7	65	160	84	200	84	200	94	250	94	250	114	300	-	-	-	-

	R	R1	Kg	Albero veloce / Input shaft Antriebswelle / Arbre d'entrée						P71		P80		P90		P100		P112		P132	
				V	V1	Kg	V	V1	Kg	E	P	E	P	E	P	E	P	E	P	E	P
305 R2	161	140	90	137.5	24	6	158	38	7	65	160	84	200	84	200	94	250	94	250	114	300
305 R3	226	122	92	137.5	24	6	158	38	7	65	160	84	200	84	200	94	250	94	250	-	-
305 R4	279	122	95	137.5	24	6	158	38	7	65	160	84	200	84	200	94	250	94	250	-	-

	S1 - M1S			S1 - M1L			S2 - M2S			S3 - M3S			S3 - M3L			S4 - M4			S5 - M5S			S5 - M5L		
	X1	X2	Y1	X1	X2	Y1	X1	X2	Y1	X1	X2	Y1	X1	X2	Y1	X1	X2	Y1	X1	X2	Y1	X1	X2	Y1
305 L1	-	-	-	-	-	-	-	-	-	-	-	-	-	-	-	460	571	258	552	692	310	596	736	310
305 L2	229	292	138	253	314	138	280	352	156	325	421	195	357	449	195	460	571	258	-	-	-	-	-	-
305 L3	229	292	138	253	314	138	280	352	156	325	421	195	357	449	195	460	571	258	-	-	-	-	-	-
305 L4	229	292	138	253	314	138	280	352	156	325	421	195	357	449	195	460	571	258	-	-	-	-	-	-

	S1 - M1S			S1 - M1L			S2 - M2S			S3 - M3S			S3 - M3L			S4 - M4		
	X1	X2	Y1	X1	X2	Y1	X1	X2	Y1	X1	X2	Y1	X1	X2	Y1	X1	X2	Y1
305 R2	-	-	-	-	-	-	328	400	156	373	469	195	405	497	195	508	619	258
305 R3	229	292	138	253	314	138	328	400	156	373	469	195	405	497	195	508	619	258
305 R4	229	292	138	253	314	138	328	400	156	373	469	195	405	497	195	508	619	258

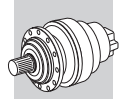

Il diagramma seguente consente di ricavare il carico radiale ammissibile R_{x2} quando questo è applicato alla distanza x dallo spallamento dell'albero lento del riduttore 305_VK.

Le curve si riferiscono al valore risultante dal rapporto fra il carico assiale A_{n2} e il carico radiale R_{n2} , entrambi riferiti a $n_2 = 10 \text{ min}^{-1}$ e durata teorica di 10000 h.

The diagram below allows the calculation of permitted overhung load R_{x2} on the output shaft of gearbox type 305_VK, with radial force applying at a distance x from shaft shoulder.

The curves are relevant to value resulting from the relationship of trust load A_{n2} to radial load R_{n2} , based on $n_2 = 10 \text{ min}^{-1}$ and 10000 hrs theoretical lifetime.

Das nachstehende Diagramm ermöglicht das Individuieren der zulässigen, auf die Welle des Getriebes 305_VK einwirkenden Radialkraft, die auf der Distanz x vom Anschlag der Welle selbst appliziert wird.

Die Kurven beziehen sich auf den Wert, der sich aus dem Verhältnis zwischen der Axialkraft A_{n2} und der Radialkraft R_{n2} für $n_2 = 10 \text{ min}^{-1}$ und einer Dauer von 10000 Std. ergibt.

Le diagramme suivant permet de déterminer la charge radiale admissible R_{x2} sur l'arbre lent du réducteur 305_VK appliqué à la distance x de l'épaule de l'arbre.

Les courbes se réfèrent à la valeur résultant de l'équation entre la charge axiale A_{n2} et la charge radiale R_{n2} pour $n_2 = 10 \text{ min}^{-1}$ et durée de 10000 h.

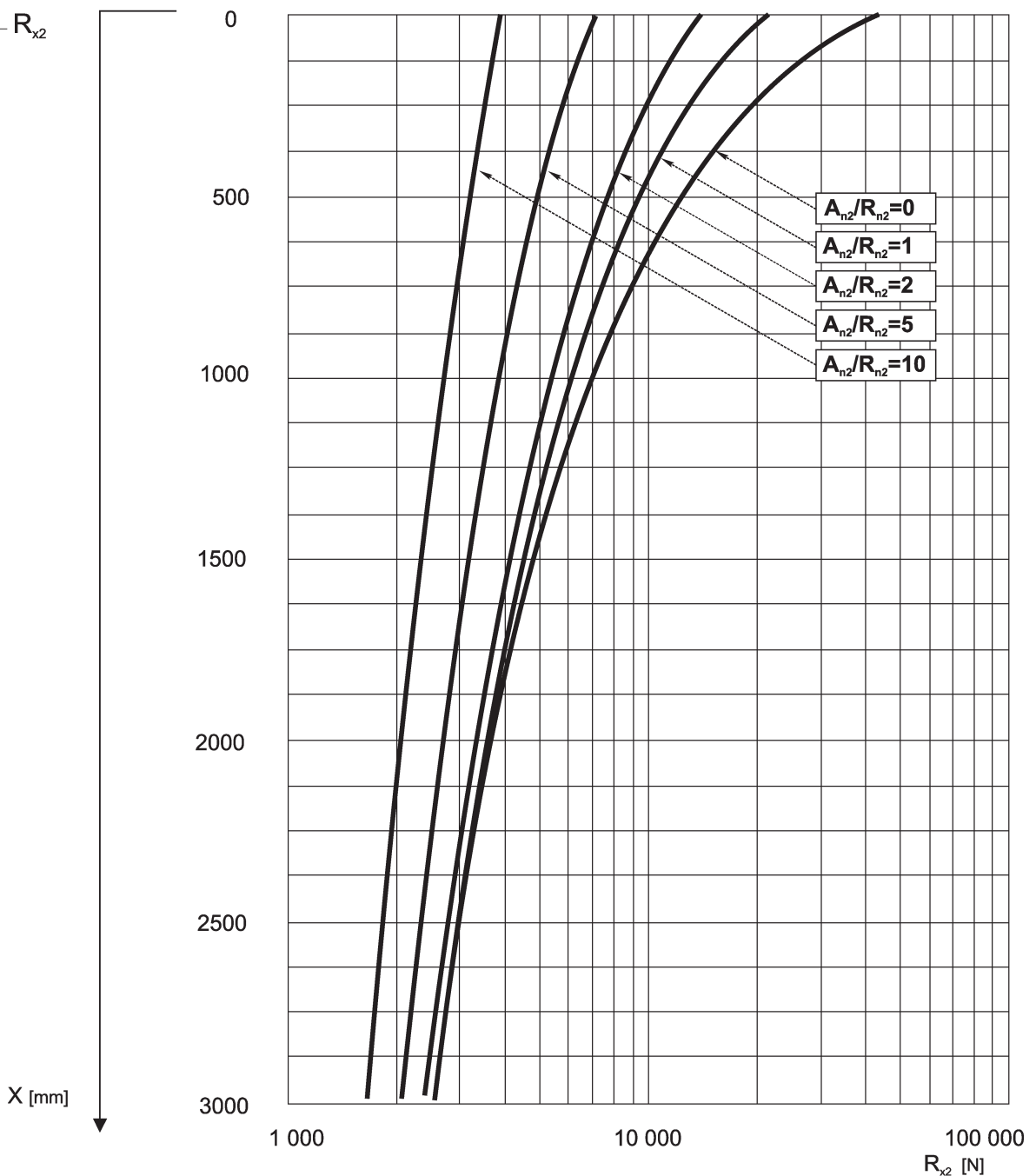
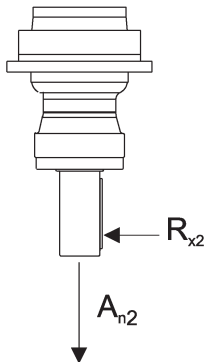

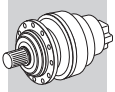

306 L

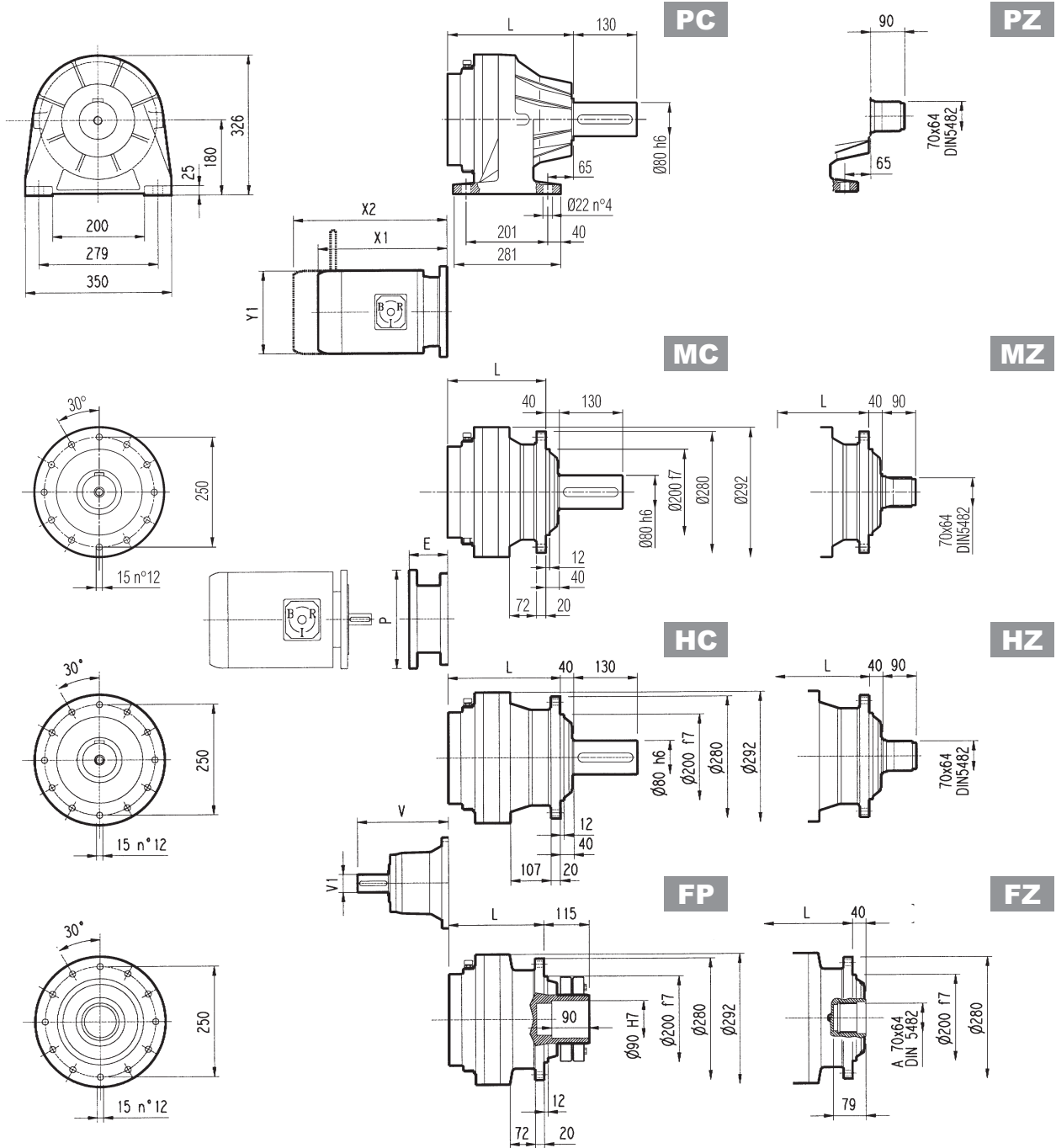

FP $M_{2max} = 12\ 000\ \text{Nm}$

	L								Kg						Albero veloce / Input shaft / Antriebswelle / Arbre d'entrée					
	MC - MZ		PC - PZ		HC - HZ		FP - FZ		MC - MZ	PC - PZ	HC - HZ	FP - FZ	V	V1	Kg	V	V1	Kg		
306 L1	160	235	195	160	65	85	70	65	307	60	23	-	-	-	-	-	-	-		
306 L2	225	300	260	225	74	95	79	74	239	48	15	-	-	-	-	-	-	-		
306 L3	278	353	313	278	78	98	83	78	137.5	24	6	158	38	7	-	-	-	-		
306 L4	331	406	366	331	82	103	87	82	137.5	24	6	158	38	7	-	-	-	-		

	P71		P80		P90		P100		P112		P132		P160		P180		P200L		P225	
	E	P	E	P	E	P	E	P	E	P	E	P	E	P	E	P	E	P	E	P
306 L1	-	-	-	-	-	-	-	-	-	-	-	-	144	350	153	350	183	400	212	450
306 L2	-	-	-	-	-	-	-	-	-	-	114	300	144	350	144	350	-	-	-	-
306 L3	65	160	84	200	84	200	94	250	94	250	114	300	-	-	-	-	-	-	-	-
306 L4	65	160	84	200	84	200	94	250	-	-	-	-	-	-	-	-	-	-	-	-

	S1 - M1S			S1 - M1L			S2 - M2S			S3 - M3S			S3 - M3L			S4 - M4			S5 - M5S			S5 - M5L		
	X1	X2	Y1	X1	X2	Y1	X1	X2	Y1	X1	X2	Y1	X1	X2	Y1	X1	X2	Y1	X1	X2	Y1	X1	X2	Y
306 L1	-	-	-	-	-	-	-	-	-	-	-	-	-	-	-	-	-	-	-	-	-	-	-	
306 L2	-	-	-	-	-	-	-	-	-	-	-	-	-	-	460	571	258	552	692	310	596	736	310	
306 L3	229	292	138	253	314	138	280	352	156	325	421	195	357	449	195	460	571	258	-	-	-	-	-	
306 L4	229	292	138	253	314	138	280	352	156	325	421	195	357	449	195	460	571	258	-	-	-	-	-	

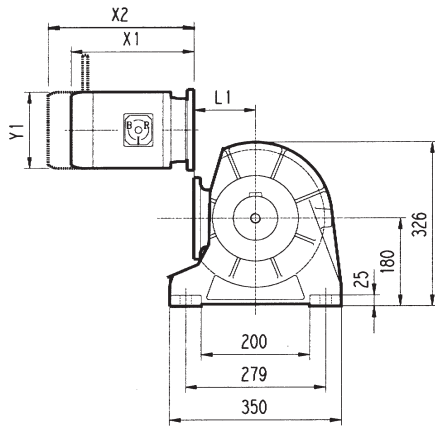
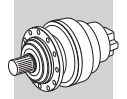

PC

PZ

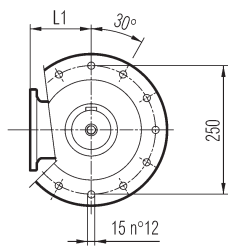
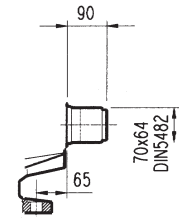
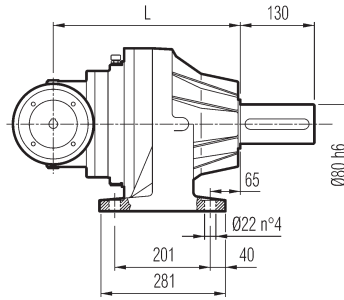

MC

MZ

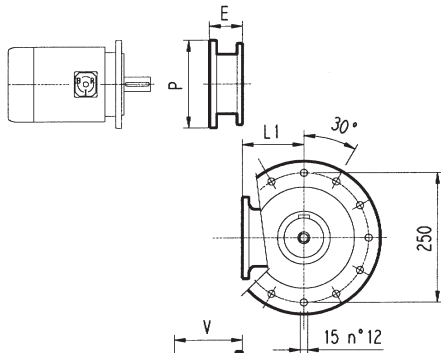
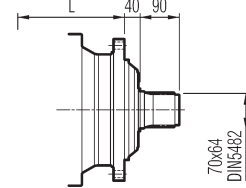
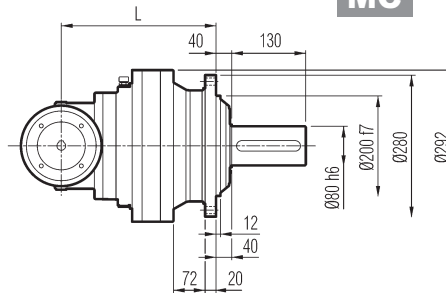

HC

HZ

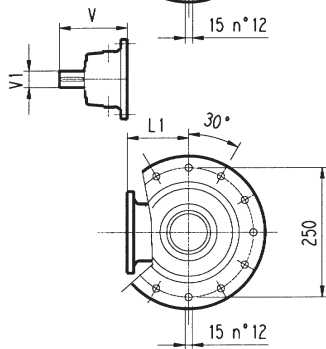
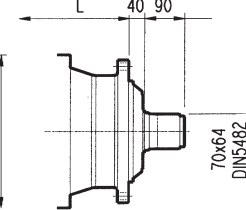
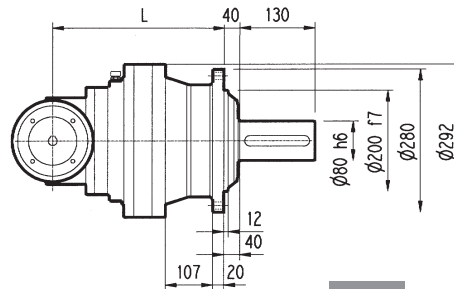

FP

FZ

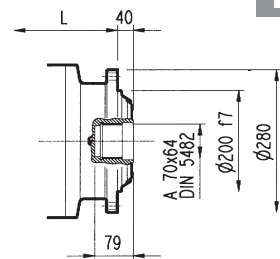
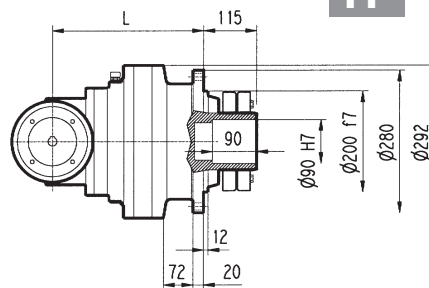

FP

$M_{2max} = 12\ 000\ Nm$

	L				L1	Kg				Albero veloce / Input shaft / Antriebswelle / Arbre d'entrée					
	MC - MZ	PC - PZ	HC - HZ	FP - FZ		MC - MZ	PC - PZ	HC - HZ	FP - FZ	V	V1	Kg	V	V1	Kg
306 R2	297	372	332	297	140	89	105	94	89	137.5	24	6	158	38	7
306 R3	317	392	352	317	140	85	100	90	85	137.5	24	6	158	38	7
306 R4	370	445	405	370	122	79	95	84	79	137.5	24	6	158	38	7

	P71		P80		P90		P100		P112		P132		P160M	
	E	P	E	P	E	P	E	P	E	P	E	P	E	P
306 R2	65	160	84	200	84	200	94	250	94	250	114	300	144	350
306 R3	65	160	84	200	84	200	94	250	94	250	114	300	-	-
306 R4	65	160	84	200	84	200	94	250	94	250	114	300	-	-

	S1 - M1S			S1 - M1L			S2 - M2S			S3 - M3S			S3 - M3L			S4 - M4		
	X1	X2	Y1	X1	X2	Y1	X1	X2	Y1	X1	X2	Y1	X1	X2	Y1	X1	X2	Y1
306 R2	-	-	-	-	-	-	328	400	156	373	469	195	405	497	195	508	619	258
306 R3	229	292	138	253	314	138	328	400	156	373	469	195	405	497	195	508	619	258
306 R4	229	292	138	253	314	138	328	400	156	373	469	195	405	497	195	508	619	258

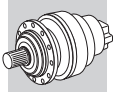

3/V 06L3

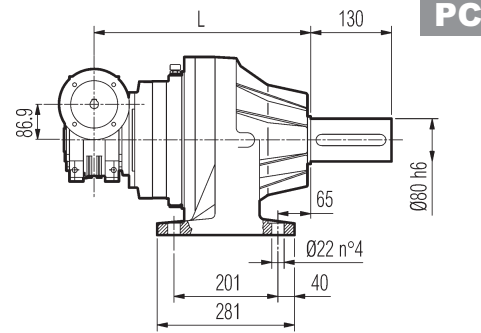
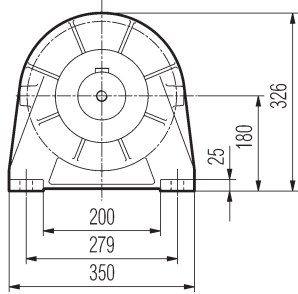

PC

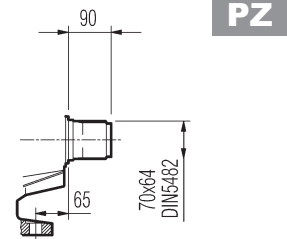

PZ

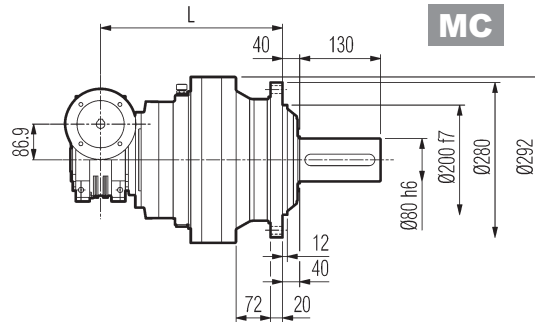
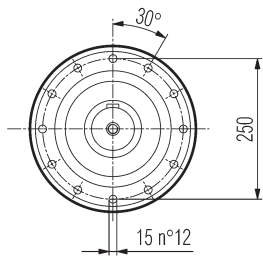

MC

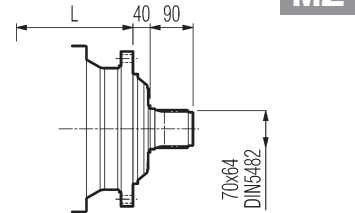

MZ

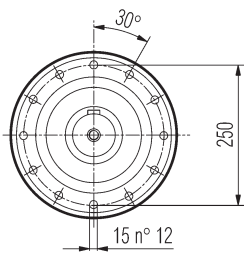

A

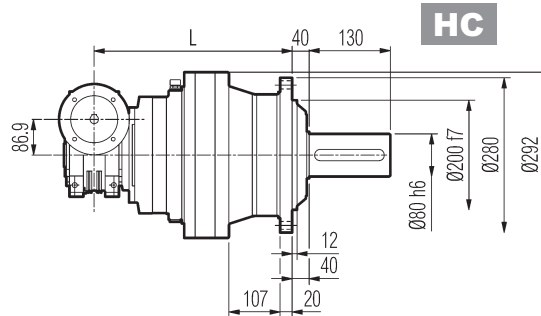

HC

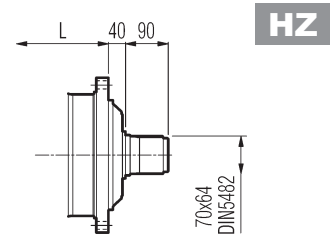

HZ

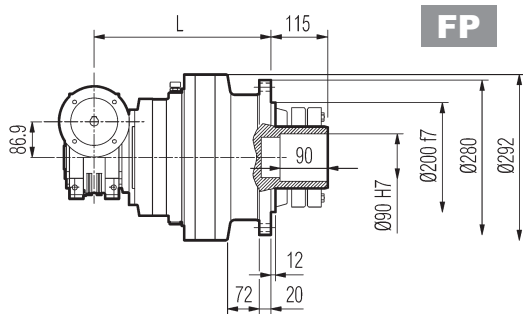
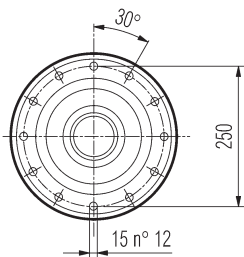

FP

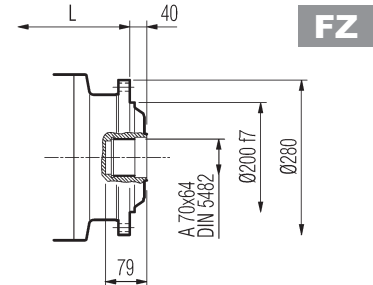

FZ

VISTA DA A
VIEW FROM A

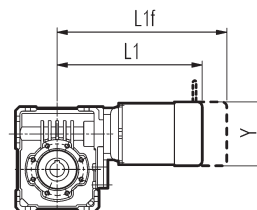
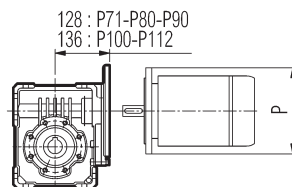
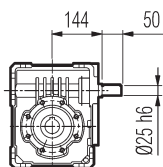

FP

$M_{2max} = 12\ 000\ \text{Nm}$

	L				Kg				P71	P80	P90	P100	P112
	MC - MZ	PC - PZ	HC - HZ	FP - FZ	MC - MZ	PC - PZ	HC - HZ	FP - FZ	P	P	P	P	P
3/V 06L3	370	445	405	370	80	111	95	80	160	200	200	250	250

	S1 - M1S			S1 - M1L			S2 - M2S			S3 - M3S			S3 - M3L		
	L1	L1f	Y	L1	L1f	Y	L1	L1f	Y	L1	L1f	Y	L1	L1f	Y
3/V 06L3	300	363	138	324	385	138	349	425	156	392	477	193	424	515	193

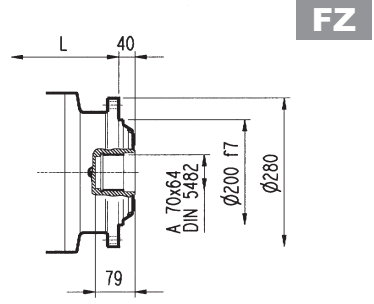
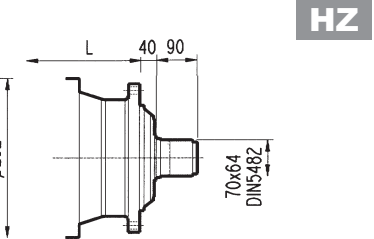
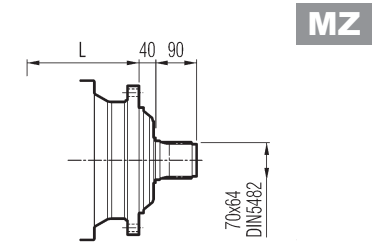
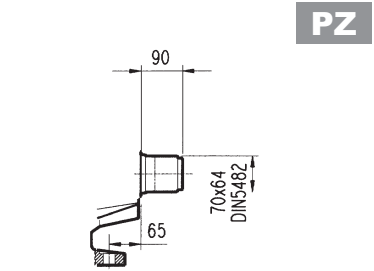
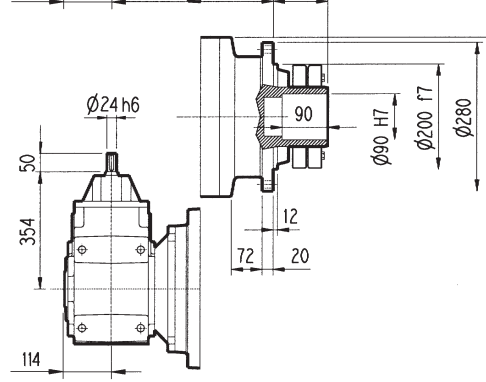
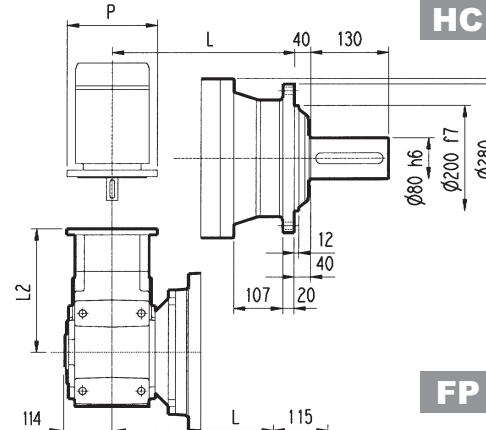
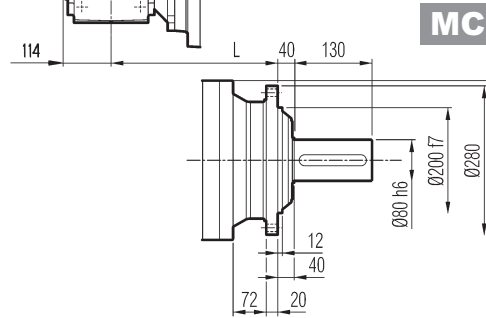
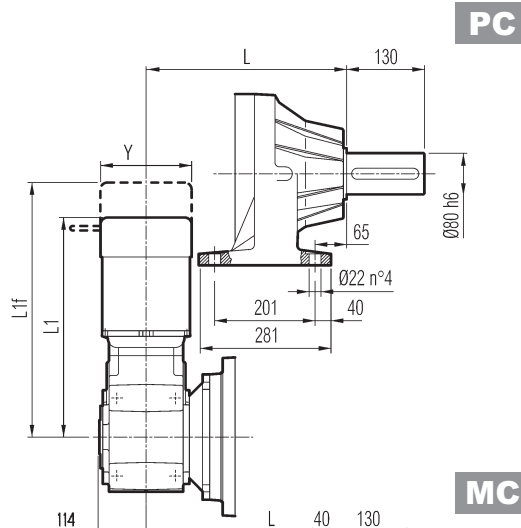
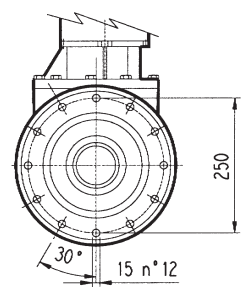
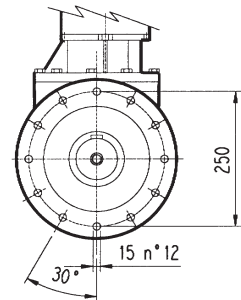
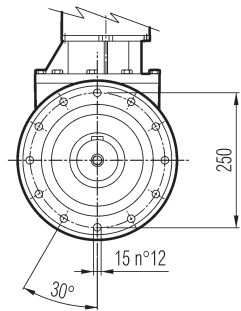
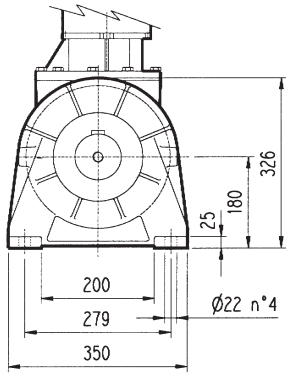
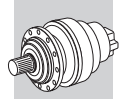

FP $M_{2max} = 12\ 000\ Nm$

	L								Kg	D1	L3	L4
	MC - MZ	PC - PZ	HC - HZ	FP - FZ	MC - MZ	PC - PZ	HC - HZ	FP - FZ				
3/A 06L2	340	415	375	340	140	170	150	140	24	354	50	

	P63		P71		P80		P90		P100		P112		P132		P160		P180	
	L2	P	L2	P	L2	P	L2	P	L2	P	L2	P	L2	P	L2	P	L2	P
3/A 06L2	314.5	140	314.5	160	334	200	334	200	344	250	344	250	380.5	300	431	350	431	350

	S1 - M1			S2 - M2S			S3 - M3SA			S3 - M3LA			S4 - M4		
	L1	L1f	Y	L1	L1f	Y	L1	L1f	Y	L1	L1f	Y	L1	L1f	Y
3/A 06L2	445	508	138	568	517	156	541	637	195	572	665	195	678	789	258

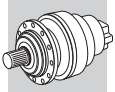

306 L

306 R

3/V 06L3

3/A 06L2

MC HC

PC

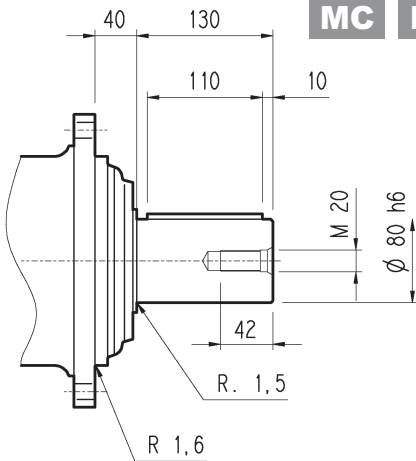

A 22x14x110
UNI 6604
DIN 6885

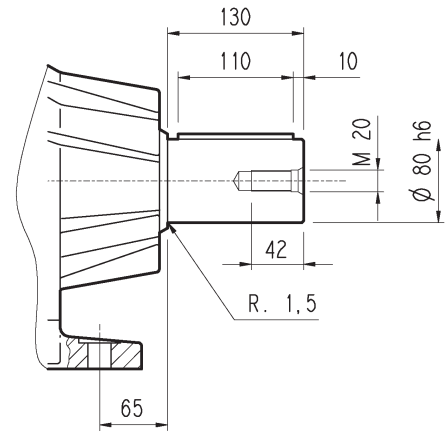
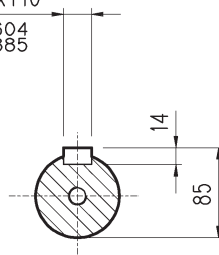

MZ HZ

FZ

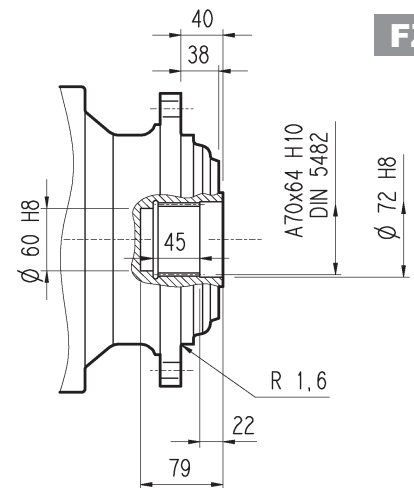
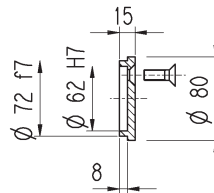
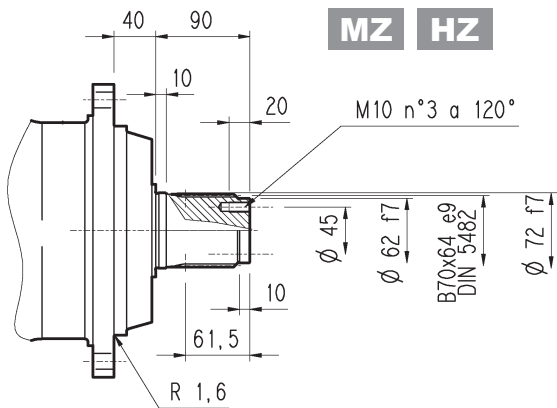

FP

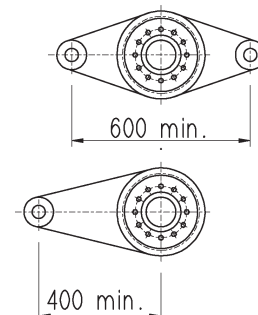
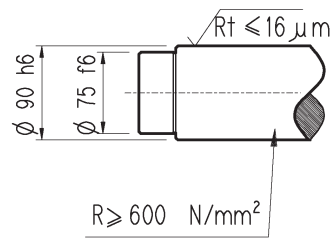
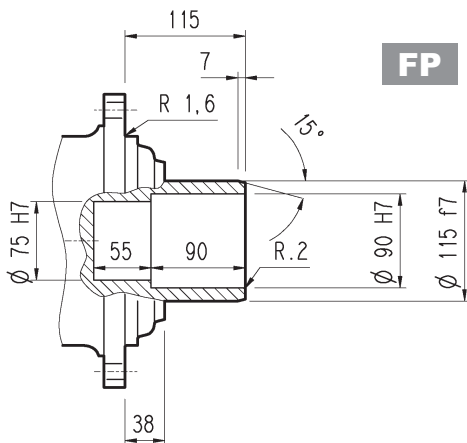

FP

$M_{2max} = 12\ 000\ Nm$

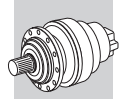
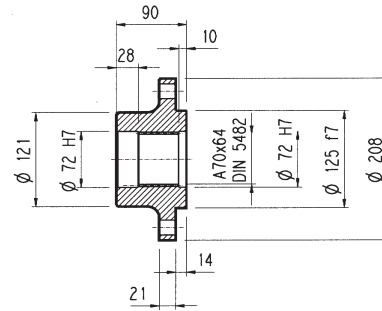
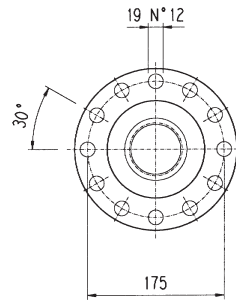
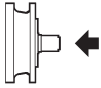
306 L**306 R****3/V 06L3****3/A 06L2**
Flangia / Flange
Flansch / Brides
W0A
 Materiale : Acciaio C40
 Material : Steel C40
 Material : Stahl C40
 Matière : Acier C40

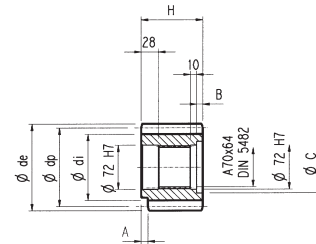
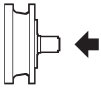
Pignoni / Pinion gears
Ritzel / Pignons
P...

	m	z	x	dp	di	de	H	A	B	C	☆
PFF1	8	15	0	120	100	134	90	0	0	0	□
PFF2	8	15	0.500	120	108	141	90	0	0	0	□
PHB	10	11	0.500	110	95	136	90	10	0	0	□
PHC1	10	12	0.450	120	104	145	90	0	0	0	□
PHC2	10	12	0.320	120	100	144.2	90	0	0	0	□
PHC3	10	12	0.350	120	101	144	90	0	0	0	□
PHD1	10	13	0.950	130	124	165	90	0	0	0	□
PHD2	10	13	0.500	130	115	159	90	0	0	0	□
PHE1	10	14	0	140	115	160	90	0	0	0	□
PHE2	10	14	0.500	140	125	166	90	0	0	0	■
PHF	10	15	0	150	127	167	90	24	0	0	□
PHH	10	17	0.480	170	154	197.5	90	10	0	0	□

☆	Materiale / Material / Material / Matière
□	Acciaio 39NiCrMo3 Bonificato Steel 39NiCrMo3 hardened and tempered Vergüteter Stahl 39NiCrMo3 Acier bonifiée 39NiCrMo3
■	Acciaio 18NiCrMo5 Cementato e temprato Steel 18NiCrMo5 Case hardened Einsatzstahl 18NiCrMo5 Einsatzgehärtet Acier cémentée et tempré 18NiCrMo5

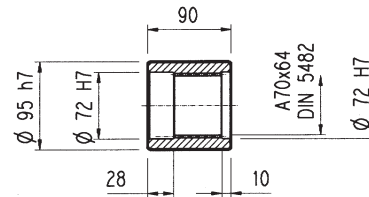
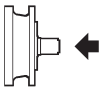
Manicotti lisci / Sleeve couplings
Naben / Manchons lisses a cannelure interieure
MOA
 Materiale : Acciaio 16CrNi4
 Material : Steel 16CrNi4
 Material : Stahl 16CrNi4
 Matière : Acier 16CrNi4

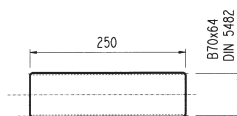
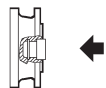
Barre scanalate / Splined bars
Vielkeilwellen / Barre cannelée
B0A
 Mat. acciaio 18NiCrMo5 UNI 5331 da cementare e
 temprare 50-55 HRC
 Case hardening steel 18NiCrMo5 UNI 5331 must be case
 hardened 50-55 HRC
 Material: Einsatzstahl 18NiCrMo5 UNI 5331 muss einsatzgehärtet
 werden 50-55 HRC
 Acier 18 NiCrMo5 UNI 5331 doit être cémenté trempé 50-55 HRC

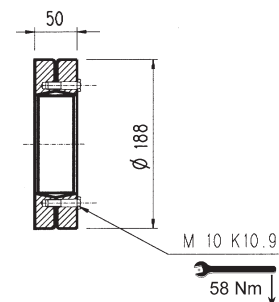
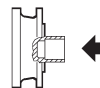
Giunto ad attrito / Shrink disc
Schrumpfscheibe / Frette de serrage
GOA

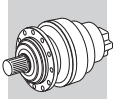

306 L

306 R

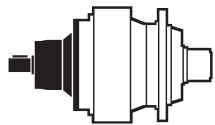
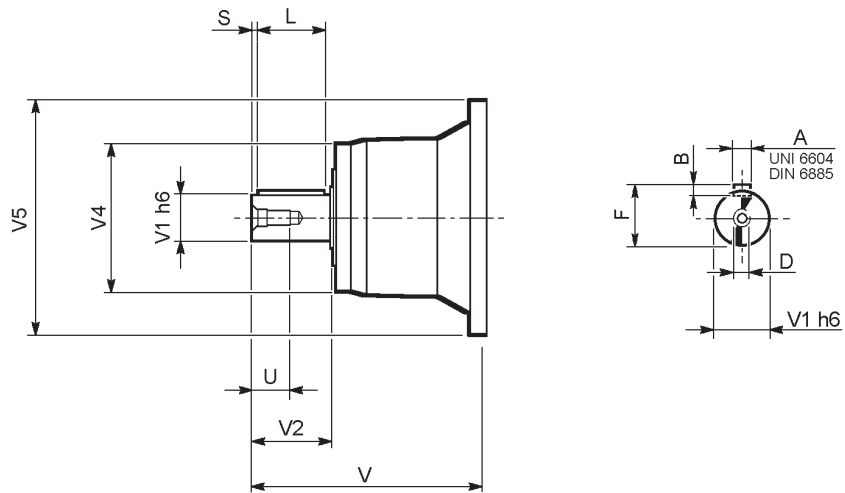

	CODE	V	V1	V2	V4	V5	A	B	F	L	S	D	U
306 L1	V06B	307	60	105	155	292	18	11	64	90	7.5	M16	36
306 L2	V05B	239	48	82	155	245	14	9	51.5	70	6	M16	36
306 L3	V01A	137.5	24	36	120	186	8	7	27	30	3	M8	19
	V01B	158	38	58	120	186	10	8	41	50	4	M12	28
306 L4	V01A	137.5	24	36	120	186	8	7	27	30	3	M8	19
	V01B	158	38	58	120	186	10	8	41	50	4	M12	28
306 R2-R3-R4	V01A	137.5	24	36	120	186	8	7	27	30	3	M8	19
	V01B	158	38	58	120	186	10	8	41	50	4	M12	28

3/V 06L3

3/A 06L2

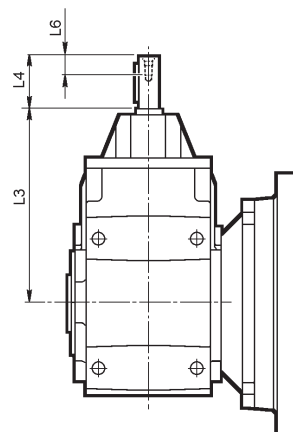
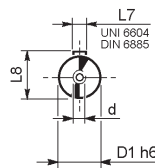
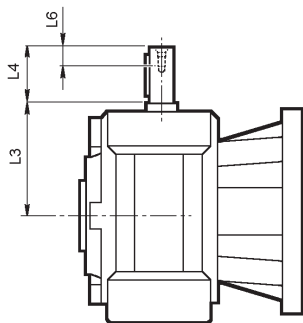
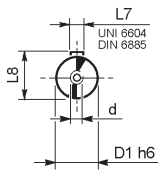

	D1 h6	L3	L4	L6	L7	L8	d
3/V 06L3_HS	25	144	50	19	8	28	M8

	D1 h6	L3	L4	L6	L7	L8	d
3/A 06L2_HS	24	354	50	19	8	27	M8

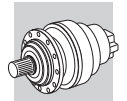

Fattore di posizione per carichi radiali sugli alberi in uscita.

Load location factor for radial loading on output shaft.

Positionsfaktor für Radialkräfte an der Abtriebswelle.

Facteur de position pour charges radiales sur les arbres en sortie.

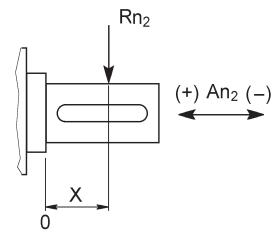
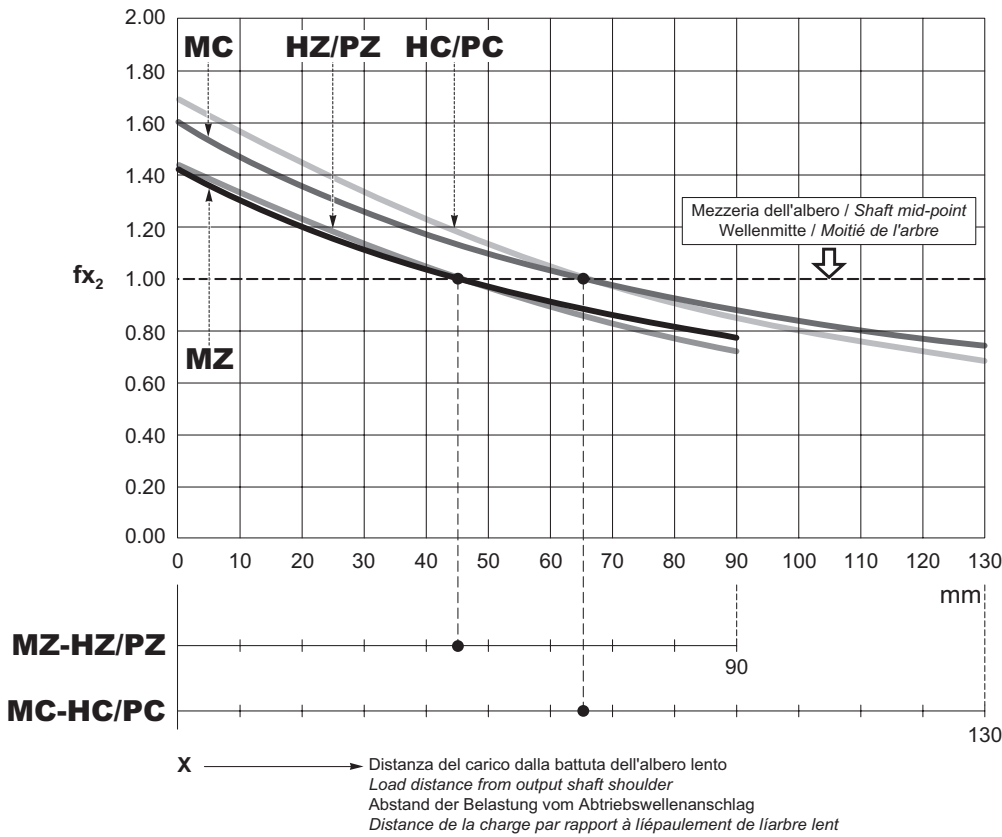

$$R_{x2} = R_{n2} \cdot f_{x2}$$

$An_2 (\pm) = R_{n2} \cdot fa_2 (\pm)$		
	$fa_2 (+)$	$fa_2 (-)$
HZ/PZ	1.01	0.50
HC/PC	1.19	0.59
MC	2.14	2.14
MZ	1.89	1.89

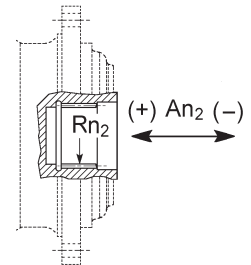

$An_2 (\pm) = R_{n2} \cdot fa_2 (\pm)$		
	$fa_2 (+)$	$fa_2 (-)$
FZ	1.00	1.00

Carichi radiali ammissibili sull'albero veloce per $n_1 = 1000 \text{ min}^{-1}$ e 10000 h di vita teorica.

Permitted overhung loads on input shaft when $n_1 = 1000 \text{ min}^{-1}$ and theoretical lifetime = 10000 h.

Zulässige Radialkräfte an den Antriebswellen für $n_1 = 1000 \text{ min}^{-1}$ und 10000 std.

Charges radiales admissibles sur les arbres d'entrée pour $n_1 = 1000 \text{ min}^{-1}$ et 10000 h.

Per velocità di comando e/o durate diverse vedi il capitolo: Verifiche.

For drive speed and/or lifetimes other than those specified here, see Chapter: Verifications.

Im Hinblick auf Geschwindigkeit und/oder anderweitige Dauern verweisen wir auf Par: Prüfungen

Pour des vitesses et/ou durées différentes, voir par. Vérifications.

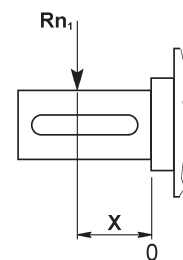
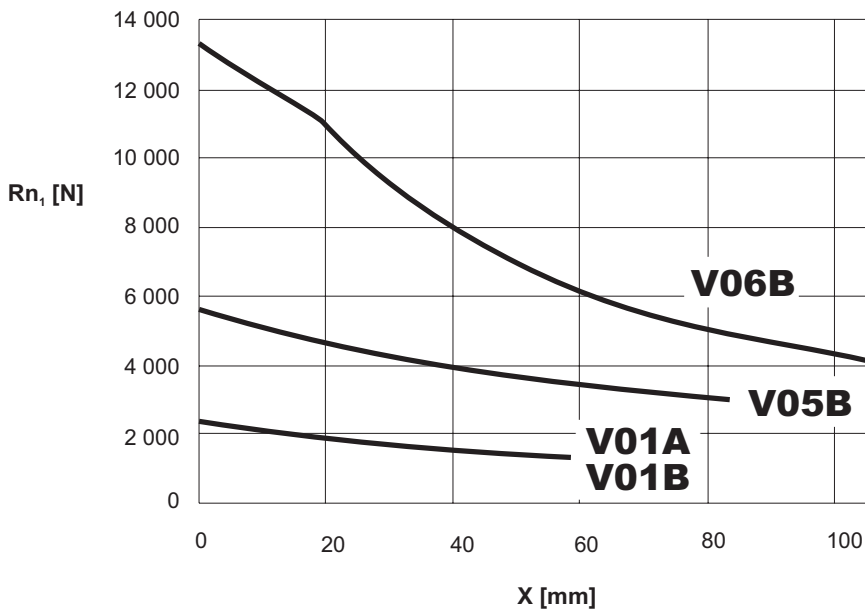

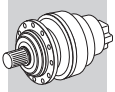

306_VK

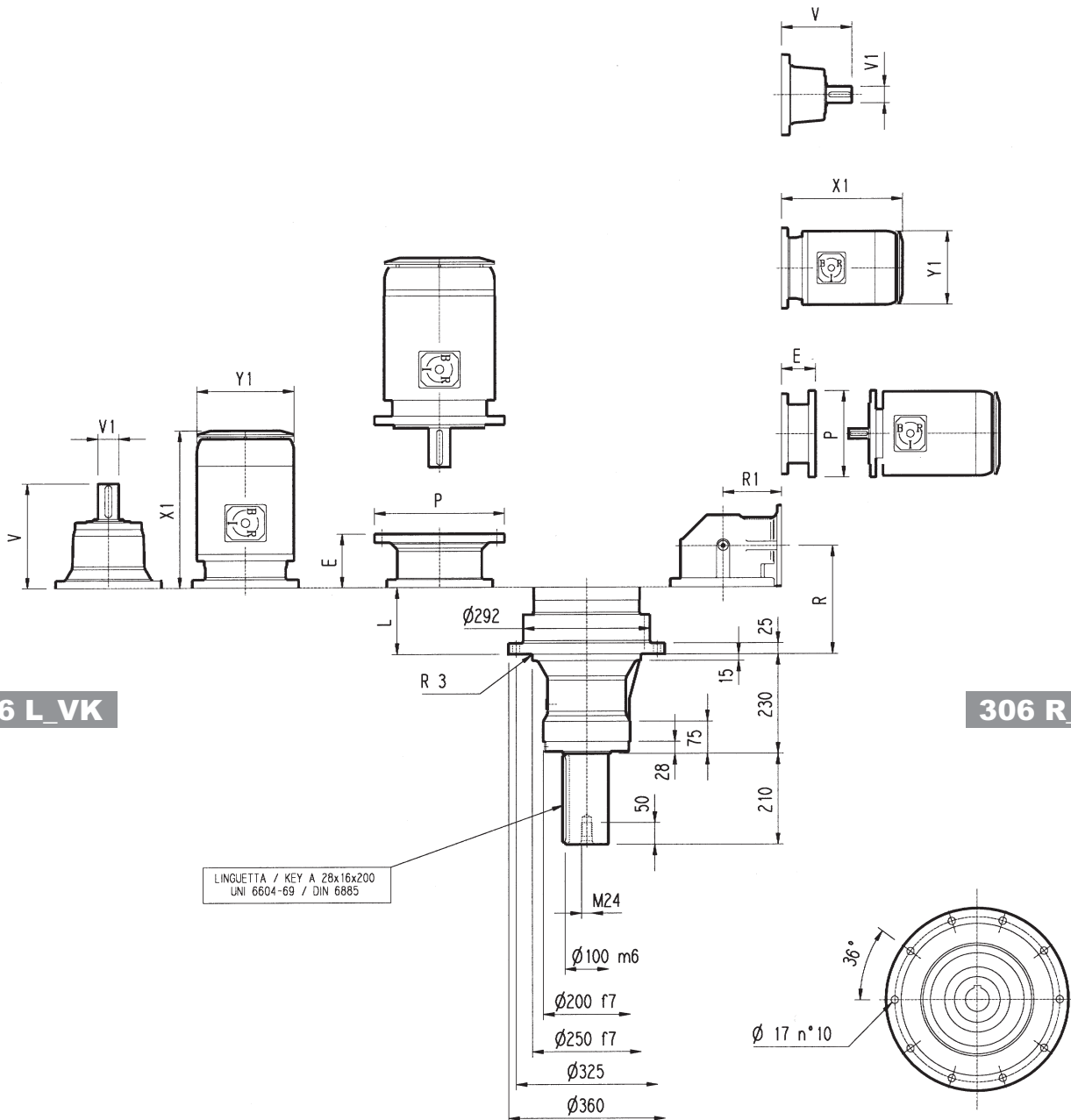

306 L_VK

306 R_VK

	L	Kg	Albero veloce / Input shaft Antriebswelle / Arbre d'entrée									P71		P80		P90		P100		P112		P132		P160		P180		P200 L		
			V	V1	Kg	V	V1	Kg	E	P	E	P	E	P	E	P	E	P	E	P	E	P	E	P	E	P	E	P		
306 L1	75	110	307	307	60	23	-	-	-	-	-	-	-	-	-	-	-	-	-	-	-	-	-	-	-	-	153	350	183	400
306 L2	140	120	239	239	48	15	-	-	-	-	-	-	-	-	-	-	-	-	-	114	300	144	350	144	350	-	-	-	-	
306 L3	193	125	137.5	137.5	24	6	158	38	7	65	160	84	200	84	200	94	250	94	250	114	300	-	-	-	-	-	-	-	-	
306 L4	246	130	137.5	137.5	24	6	158	38	7	65	160	84	200	84	200	94	250	94	250	114	300	-	-	-	-	-	-	-	-	

	R	R1	Kg	Albero veloce / Input shaft Antriebswelle / Arbre d'entrée									P71		P80		P90		P100		P112		P132		P160		
				V	V1	Kg	V	V1	Kg	E	P	E	P	E	P	E	P	E	P	E	P	E	P	E	P		
306 R2	212	140	130	137.5	24	6	158	38	7	65	160	84	200	84	200	94	250	94	250	114	300	144	350	144	350	-	-
306 R3	232	140	125	137.5	24	6	158	38	7	65	160	84	200	84	200	94	250	94	250	114	300	-	-	-	-	-	-
306 R4	285	122	120	137.5	24	6	158	38	7	65	160	84	200	84	200	94	250	94	250	114	300	-	-	-	-	-	-

	S1 - M1S			S1 - M1L			S2 - M2S			S3 - M3S			S3 - M3L			S4 - M4			S5 - M5S			S5 - M5L		
	X1	X2	Y1	X1	X2	Y1	X1	X2	Y1	X1	X2	Y1	X1	X2	Y1	X1	X2	Y1	X1	X2	Y1	X1	X2	Y1
306 L1	-	-	-	-	-	-	-	-	-	-	-	-	-	-	-	-	-	-	-	-	-	-	-	-
306 L2	-	-	-	-	-	-	-	-	-	-	-	-	-	-	-	460	571	258	552	692	310	596	736	310
306 L3	229	292	138	253	314	138	280	352	156	325	421	195	357	449	195	460	571	258	-	-	-	-	-	-
306 L4	229	292	138	253	314	138	280	352	156	325	421	195	357	449	195	460	571	258	-	-	-	-	-	-

	S1 - M1S			S1 - M1L			S2 - M2S			S3 - M3S			S3 - M3L			S4 - M4		
	X1	X2	Y1	X1	X2	Y1	X1	X2	Y1	X1	X2	Y1	X1	X2	Y1	X1	X2	Y1
306 R2	-	-	-	-	-	-	328	400	156	373	469	195	405	497	195	508	619	258
306 R3	229	292	138	253	314	138	328	400	156	373	469	195	405	497	195	508	619	258
306 R4	229	292	138	253	314	138	328	400	156	373	469	195	405	497	195	508	619	258

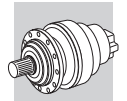

Il diagramma seguente consente di ricavare il carico radiale ammissibile R_{x2} quando questo è applicato alla distanza x dallo spallamento dell'albero lento del riduttore 306_VK.

Le curve si riferiscono al valore risultante dal rapporto fra il carico assiale A_{n2} e il carico radiale R_{n2} , entrambi riferiti a $n_2 = 10 \text{ min}^{-1}$ e durata teorica di 10000 h.

The diagram below allows the calculation of permitted overhung load R_{x2} on the output shaft of gearbox type 306_VK, with radial force applying at a distance x from shaft shoulder.

The curves are relevant to value resulting from the relationship of trust load A_{n2} to radial load R_{n2} , based on $n_2 = 10 \text{ min}^{-1}$ and 10000 hrs theoretical lifetime.

Das nachstehende Diagramm ermöglicht das Individuieren der zulässigen, auf die Welle des Getriebes 306_VK einwirkenden Radialkraft, die auf der Distanz x vom Anschlag der Welle selbst appliziert wird.

Die Kurven beziehen sich auf den Wert, der sich aus dem Verhältnis zwischen der Axialkraft A_{n2} und der Radialkraft R_{n2} für $n_2 = 10 \text{ min}^{-1}$ und einer Dauer von 10000 Std. ergibt.

Le diagramme suivant permet de déterminer la charge radiale admissible R_{x2} sur l'arbre lent du réducteur 306_VK appliqué à la distance x de l'épaule de l'arbre.

Les courbes se réfèrent à la valeur résultant de l'équation entre la charge axiale A_{n2} et la charge radiale R_{n2} pour $n_2 = 10 \text{ min}^{-1}$ et durée de 10000 h.

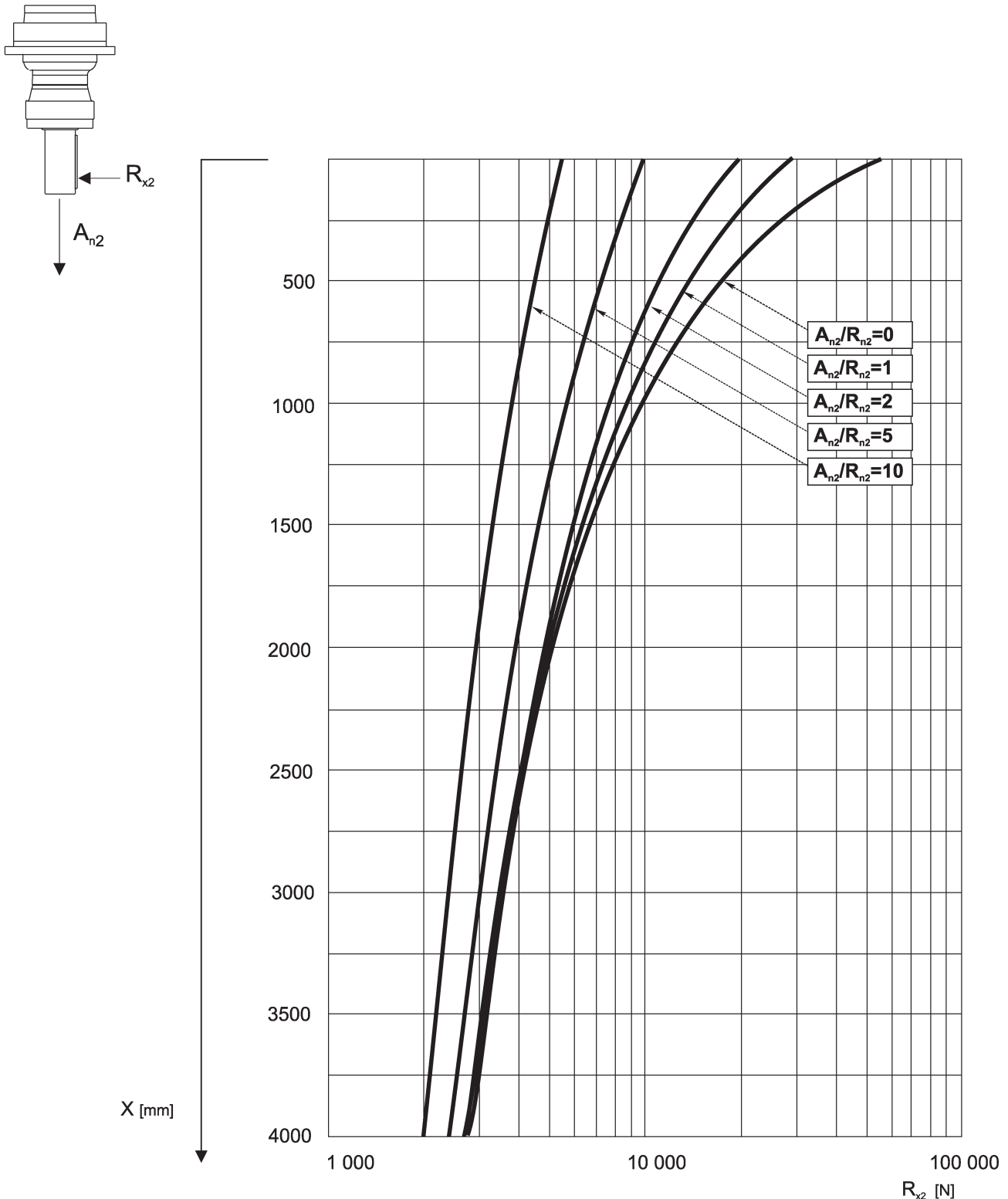

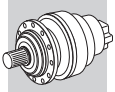

307 L

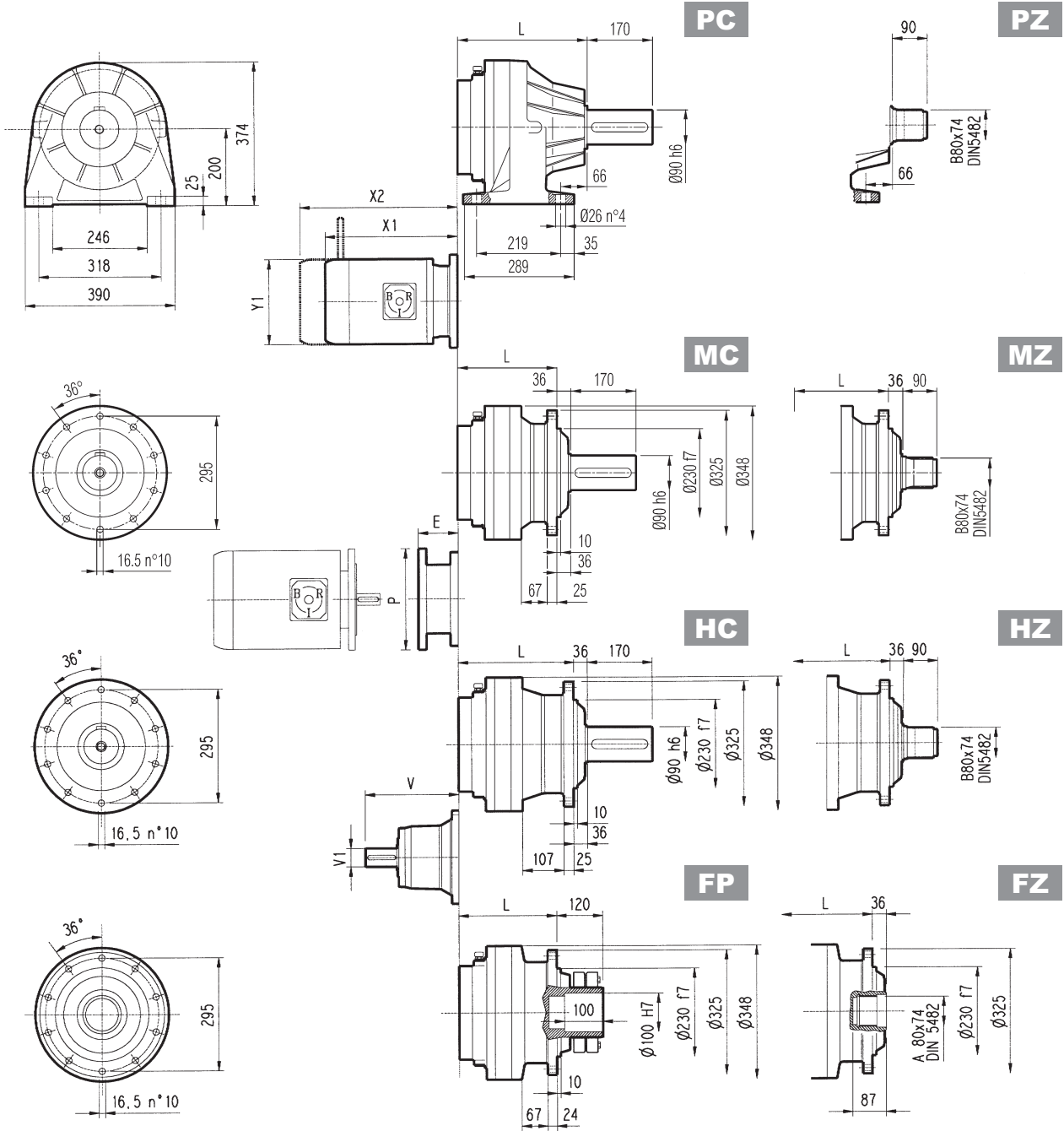

FP $M_{2max} = 18\ 000\ \text{Nm}$

	L				Kg				Albero veloce / Input shaft / Antriebswelle / Arbre d'entrée					
	MC - MZ	PC - PZ	HC - HZ	FP - FZ	MC - MZ	PC - PZ	HC - HZ	FP - FZ	V	V1	Kg	V	V1	Kg
307 L1	165	246	210	165	85	120	105	85	315	80	35	313	60	28
307 L2	254	335	299	254	97	132	117	97	239	48	15	-	-	-
307 L3	319	400	364	319	104	139	124	104	137.5	24	6	158	38	7
307 L4	372	453	417	372	108	143	128	108	137.5	24	6	158	38	7

	P71		P80		P90		P100		P112		P132		P160		P180		P200L		P225		P250	
	E	P	E	P	E	P	E	P	E	P	E	P	E	P	E	P	E	P	E	P	E	P
307 L1	-	-	-	-	-	-	-	-	-	-	-	-	-	-	195	350	186	400	216	450	216	550
307 L2	-	-	-	-	-	-	-	-	-	-	114	300	144	350	144	350	-	-	-	-	-	-
307 L3	65	160	84	200	84	200	94	250	94	250	114	300	144	350	-	-	-	-	-	-	-	-
307 L4	65	160	84	200	84	200	94	250	94	250	114	300	144	350	-	-	-	-	-	-	-	-

	S1 - M1S			S1 - M1L			S2 - M2S			S3 - M3S			S3 - M3L			S4 - M4			S5 - M5S			S5 - M5L		
	X1	X2	Y1	X1	X2	Y1	X1	X2	Y1	X1	X2	Y1	X1	X2	Y1	X1	X2	Y1	X1	X2	Y1	X1	X2	Y
307 L1	-	-	-	-	-	-	-	-	-	-	-	-	-	-	-	-	-	-	-	-	-	-	-	-
307 L2	-	-	-	-	-	-	-	-	-	-	-	-	-	-	-	460	571	258	552	692	310	596	736	310
307 L3	-	-	-	-	-	-	280	352	156	325	421	195	357	449	195	460	571	258	-	-	-	-	-	-
307 L4	229	292	138	253	314	138	280	352	156	325	421	195	357	449	195	460	571	258	-	-	-	-	-	-

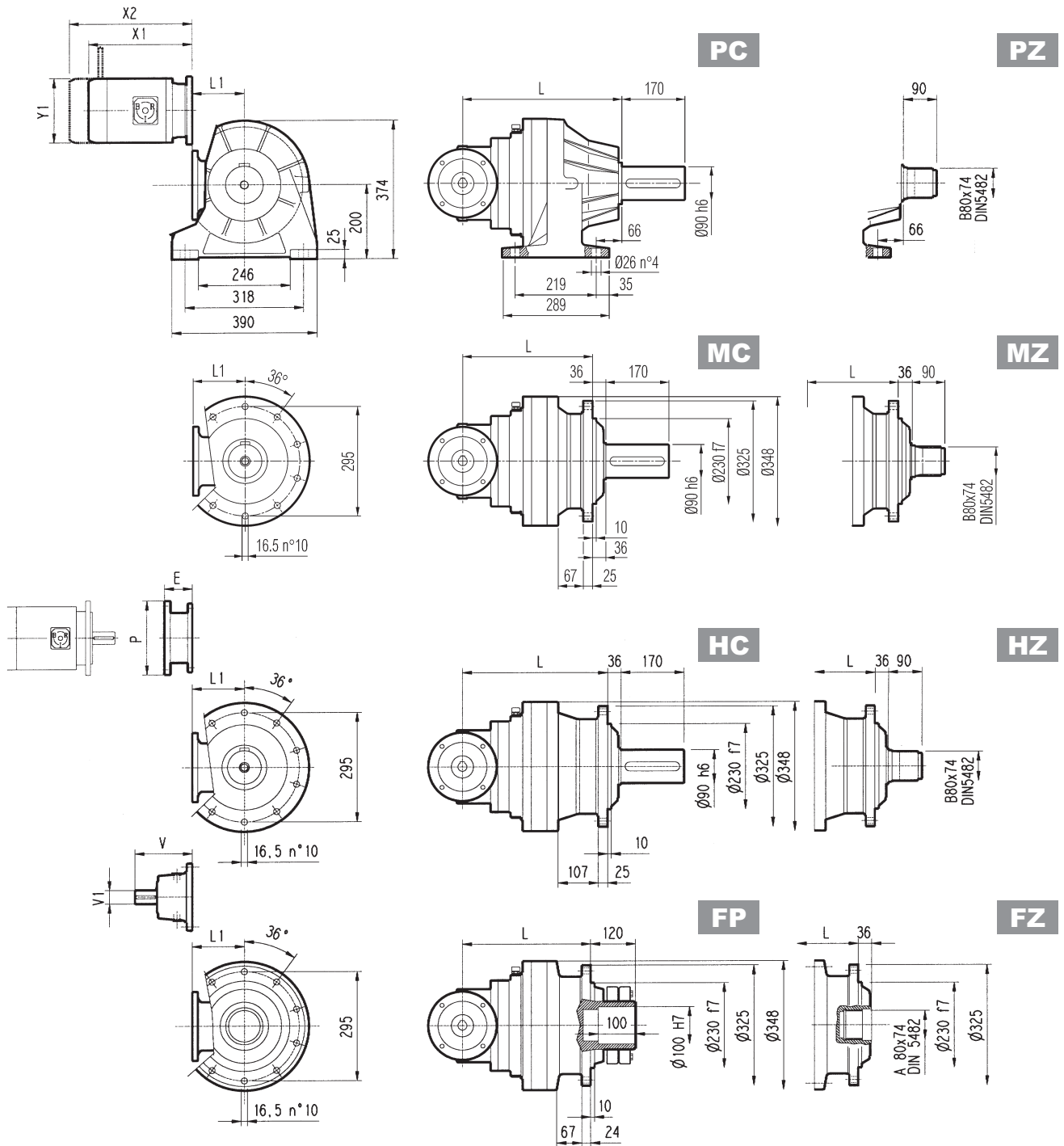
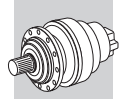

FP $M_{2max} = 18\ 000\ Nm$

	L				L1	Kg				Albero veloce / Input shaft / Antriebswelle / Arbre d'entrée					
	MC - MZ	PC - PZ	HC - HZ	FP - FZ		MC - MZ	PC - PZ	HC - HZ	FP - FZ	V	V1	Kg	V	V1	Kg
307 R2	284	365	329	284	225	135	170	155	135	239	48	15	-	-	-
307 R3	346	427	391	346	140	117	152	137	117	137.5	24	6	158	38	7
307 R4	411	492	456	411	122	118	153	138	118	137.5	24	6	158	38	7

	P71		P80		P90		P100		P112		P132		P160M		P180		P200L	
	E	P	E	P	E	P	E	P	E	P	E	P	E	P	E	P	E	P
307 R2	-	-	-	-	-	-	-	-	-	-	114	300	144	350	144	350	174	400
307 R3	65	160	84	200	84	200	94	250	94	250	114	300	144	350	-	-	-	-
307 R4	65	160	84	200	84	200	94	250	94	250	114	300	-	-	-	-	-	-

	S1 - M1S			S1 - M1L			S2 - M2S			S3 - M3S			S3 - M3L			S4 - M4			S5 - M5S			S5 - M5L		
	X1	X2	Y1	X1	X2	Y1	X1	X2	Y1	X1	X2	Y1	X1	X2	Y1	X1	X2	Y1	X1	X2	Y1	X1	X2	Y1
307 R2	-	-	-	-	-	-	-	-	-	-	-	-	-	-	-	508	619	258	552	692	310	596	736	310
307 R3	229	292	138	253	314	138	328	400	156	373	469	195	405	497	195	508	619	258	-	-	-	-	-	-
307 R4	229	292	138	253	314	138	328	400	156	373	469	195	405	497	195	508	619	258	-	-	-	-	-	-

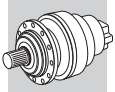

3/V 07L3

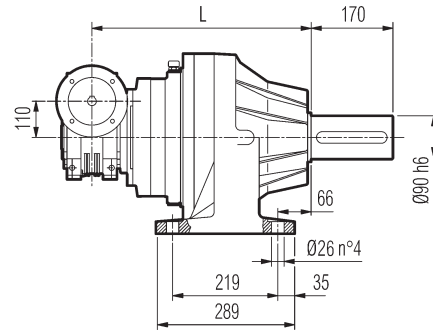
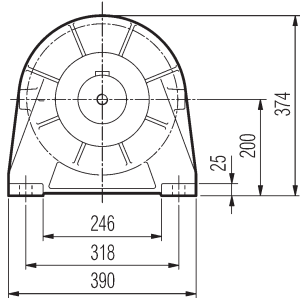

PC

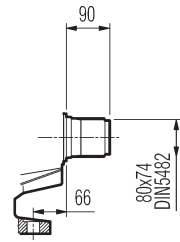

PZ

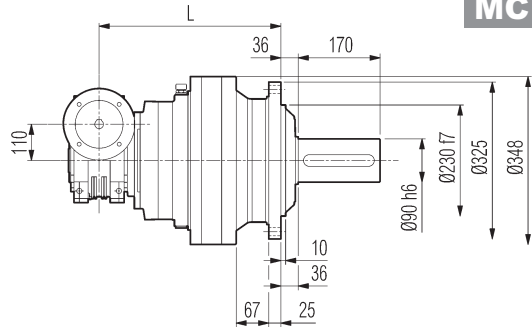
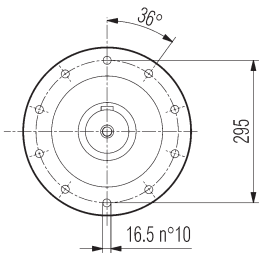

MC

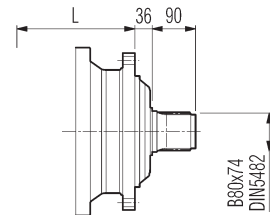

MZ

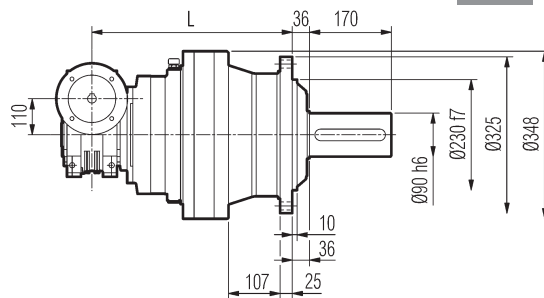
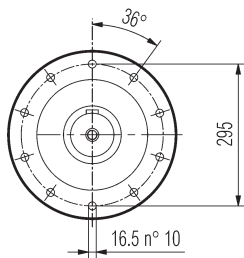

HC

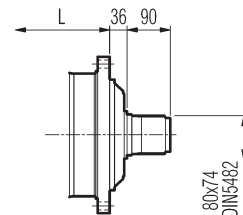

HZ

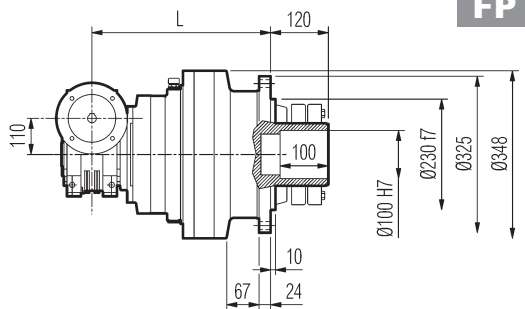
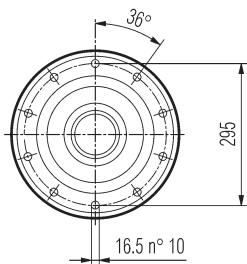

FP

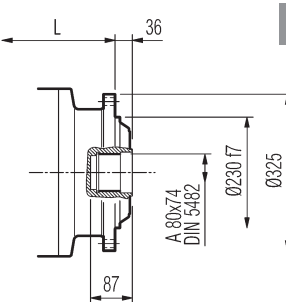

FZ

VISTA DA A
VIEW FROM A

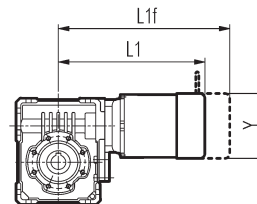
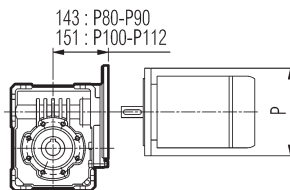
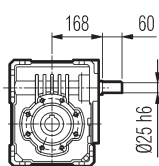

FP

M_{2max} = 18 000 Nm

	L				Kg				P80	P90	P100	P112
	MC - MZ	PC - PZ	HC - HZ	FP - FZ	MC - MZ	PC - PZ	HC - HZ	FP - FZ	P	P	P	P
3/V 07L3	414	495	459	414	130	165	150	130	200	200	250	250

	S2 - M2S			S3 - M3S			S3 - M3L		
	L1	L1f	Y	L1	L1f	Y	L1	L1f	Y
3/V 07L3	364	440	156	407	503	193	439	530	193

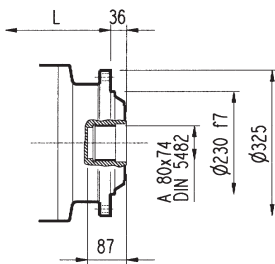
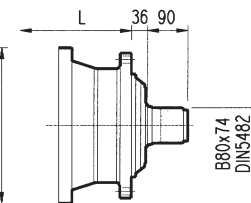
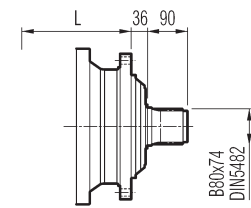
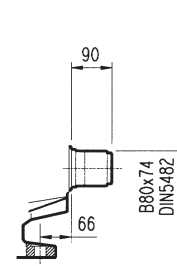
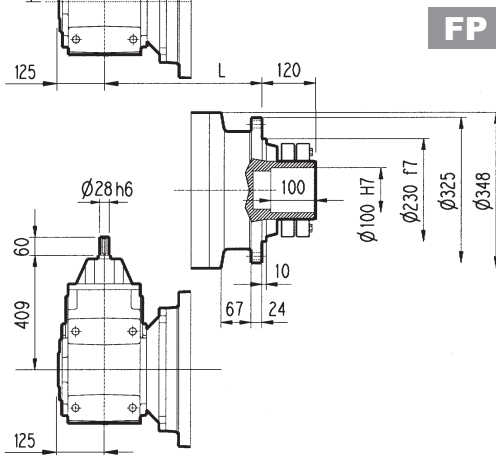
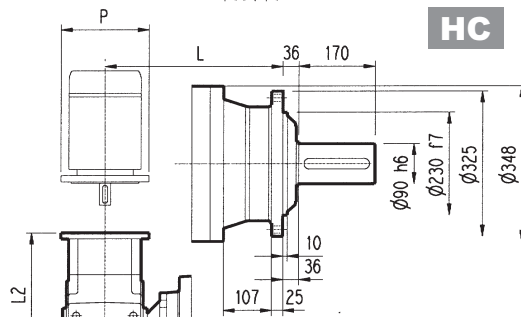
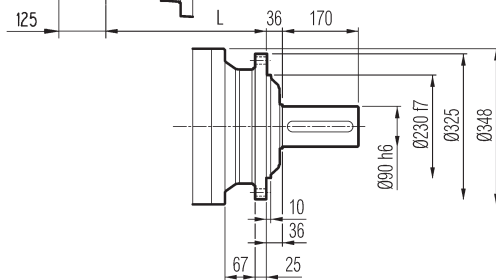
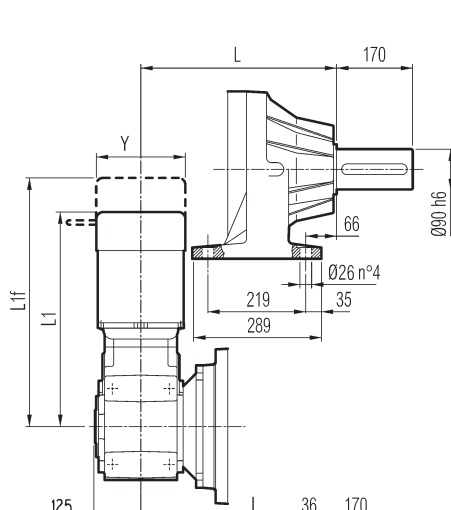
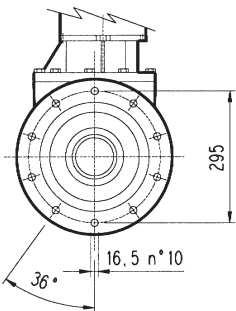
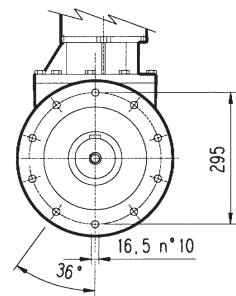
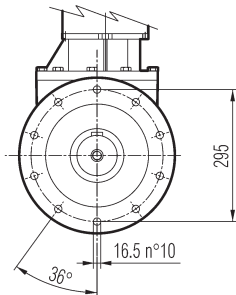
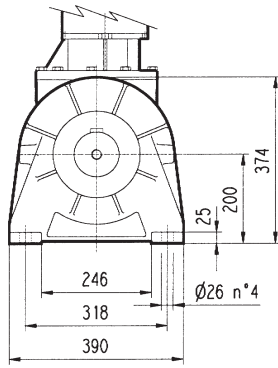
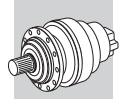

PC

PZ

MC

MZ

HC

HZ

FP

FZ

FP

M_{2max} = 18 000 Nm

3/A 07L2	L												Kg					
	MC - MZ		PC - PZ		HC - HZ		FP - FZ		MC - MZ		PC - PZ		HC - HZ		FP - FZ			
	336		417		381		336		200		230		210		200			
3/A 07L2	P80		P90		P100		P112		P132		P160		P180					
	L2	P	L2	P	L2	P	L2	P	L2	P	L2	P	L2	P				
	371	200	371	200	381	250	381	250	416.5	300	468	350	468	350				
3/A 07L2	S2 - M2			S3 - M3SA			S3 - M3LA			S4 - M4			S5 - M5S			S5 - M5L		
	L1	L1f	Y	L1	L1f	Y	L1	L1f	Y	L1	L1f	Y	L1	L1f	Y	L1	L1f	Y
	535	605	156	578.5	674.5	195	610.5	701.5	195	718.5	827.5	258	970	1110	-	1014	1154	-

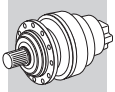

307 L

307 R

3/V 07L3

3/A 07L2

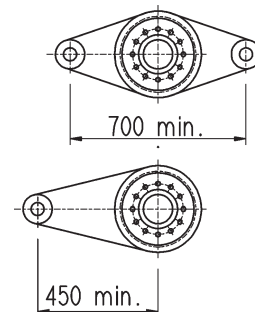
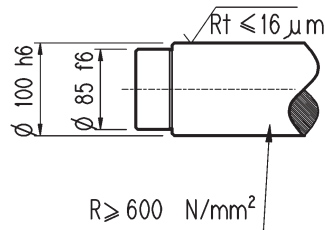
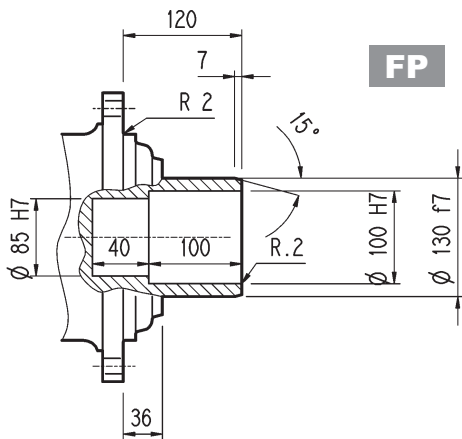
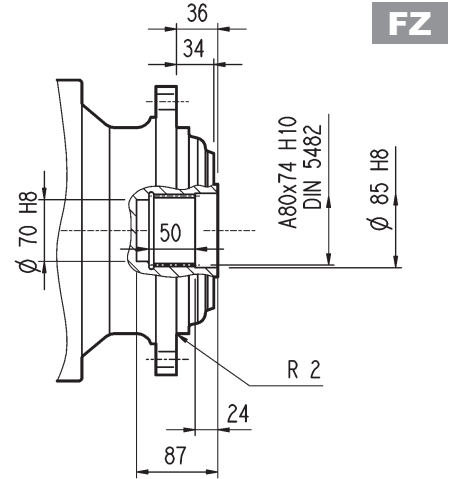
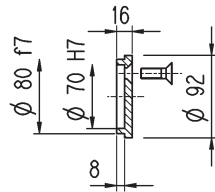
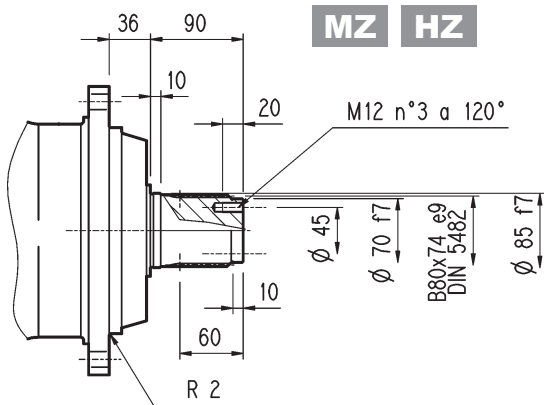
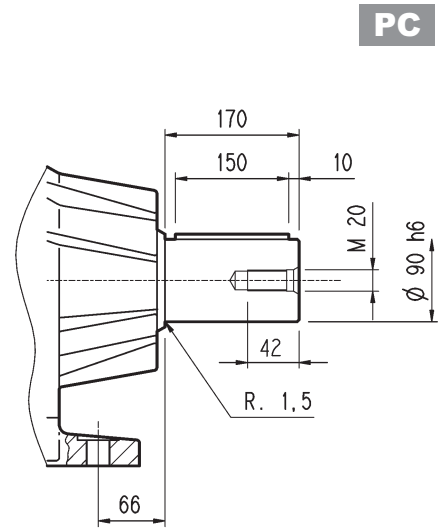
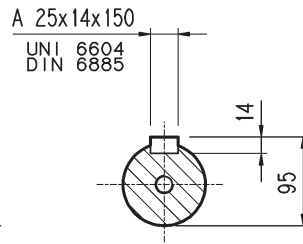
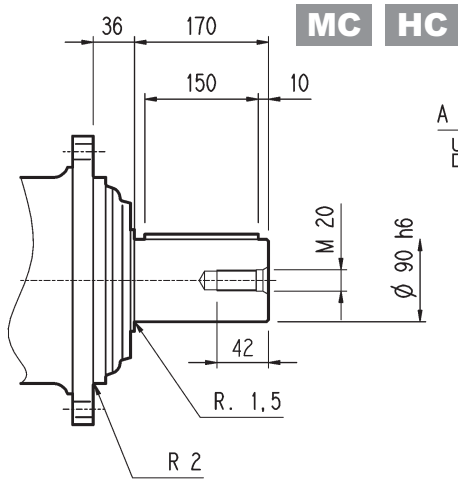

FP

$M_{2max} = 18\,000 \text{ Nm}$

307 L

307 R

3/V 07L3

3/A 07L2

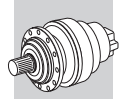

Flangia / Flange
Flansch / Brides

W0A

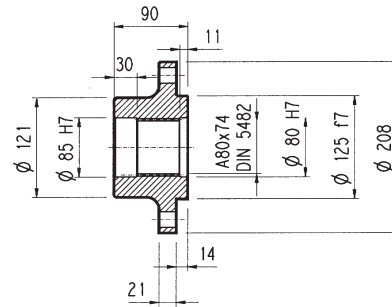
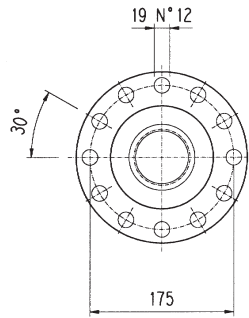
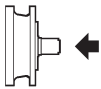

Materiale : Acciaio C40
Material : Steel C40
Material : Stahl C40
Màterial : Acier C40

Pignoni / Pinion gears
Ritzel / Pignons

P...

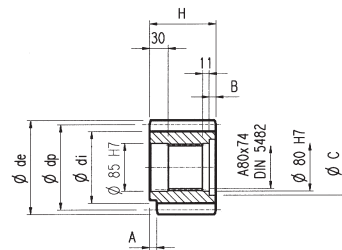
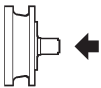

	m	z	x	dp	di	de	H	A	B	C	☆
PFG	8	16	0.500	128	117	149.5	90	0	0	0	□
PHC	10	12	0.450	120	104	145	90	0	0	0	□
PHE	10	14	0.320	140	121	162.5	116	13	26	95	□
PHF	10	15	0.150	150	130	171.5	107	20	17	100	□
PHG	10	16	0.500	160	145	186	90	0	0	0	■
PHH1	10	17	0	170	145	190	90	0	0	0	■
PHH2	10	17	0.500	170	154	198	90	0	0	0	■
PLD	12	13	0.500	156	138	192	102	0	12	95	□
PLE	12	14	0.500	168	150	199.2	90	0	0	0	□
PLI	12	18	0.500	216	198	249.6	107	7	17	95	□
PLT	12	26	0	312	282	336	90	10	0	0	■

☆	Materiale / Material / Material / Matière
□	Acciaio 39NiCrMo3 Bonificato Steel 39NiCrMo3 hardened and tempered Vergüteter Stahl 39NiCrMo3 Acier bonifiée 39NiCrMo3
■	Acciaio 18NiCrMo5 Cementato e temprato Steel 18NiCrMo5 Case hardened Einsatzstahl 18NiCrMo5 Einsatzgehärtet Acier cimenté et tempré 18NiCrMo5

Manicotti lisci / Sleeve couplings
Naben / Manchons lisses a cannelure interieure

MOA

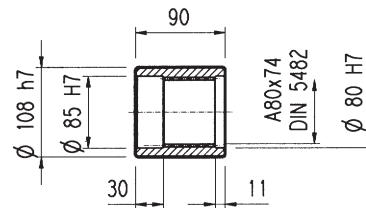
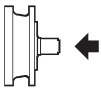

Materiale : Acciaio 16CrNi4
Material : Steel 16CrNi4
Material : Stahl 16CrNi4
Màterial : Acier 16CrNi4

Barre scanalate / Splined bars
Vielkeilwellen / Barre cannelée

B0A

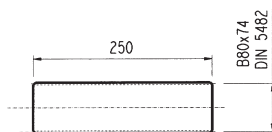
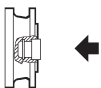

Mat. acciaio 18NiCrMo5 UNI 5331 da cementare e temprare 50-55 HRC
Case hardening steel 18NiCrMo5 UNI 5331 must be case hardened 50-55 HRC
Material: Einsatzstahl 18NiCrMo5 UNI 5331 muss einsatzgehärtet werden 50-55 HRC
Acier 18 NiCrMo5 UNI 5331 doit être cémenté trempé 50-55 HRC

Giunto ad attrito / Shrink disc
Schrumpfscheibe / Frette de serrage

GOA

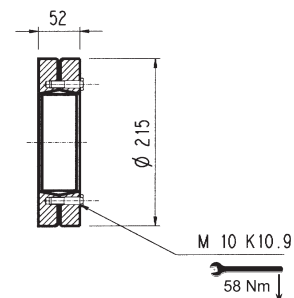
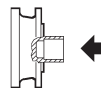

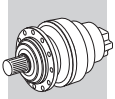

307 L

307 R

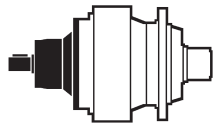
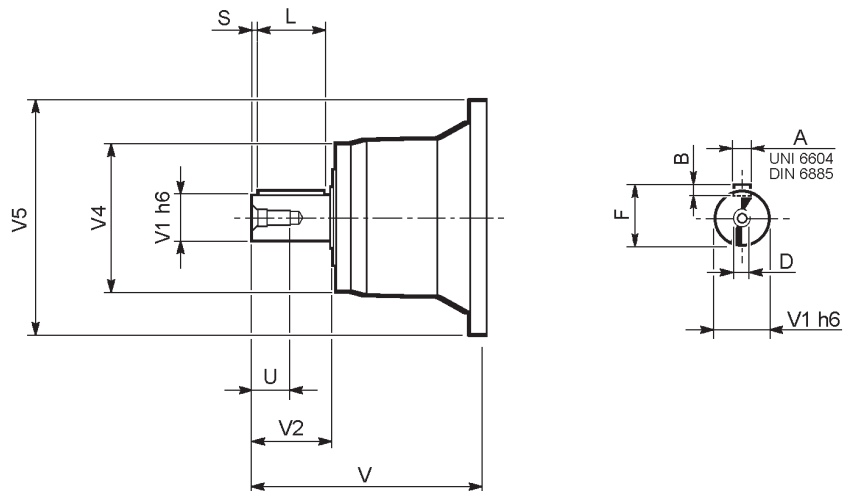

	CODE	V	V1	V2	V4	V5	A	B	F	L	S	D	U
307 L1	V07B	315	80	130	200	345	22	14	85	110	10	M16	36
	V07A	313	60	105	155	345	18	11	64	90	7.5	M16	36
307 L2	V05B	239	48	82	155	245	14	9	51.5	70	6	M16	36
307 L3	V01A	137.5	24	36	120	186	8	7	27	30	3	M8	19
	V01B	158	38	58	120	186	10	8	41	50	4	M12	28
307 L4	V01A	137.5	24	36	120	186	8	7	27	30	3	M8	19
	V01B	158	38	58	120	186	10	8	41	50	4	M12	28
307 R2	V05B	239	48	82	155	245	14	9	51.5	70	6	M16	36
307 R3-R4	V01A	137.5	24	36	120	186	8	7	27	30	3	M8	19
	V01B	158	38	58	120	186	10	8	41	50	4	M12	28

3/V 07L3

3/A 07L2

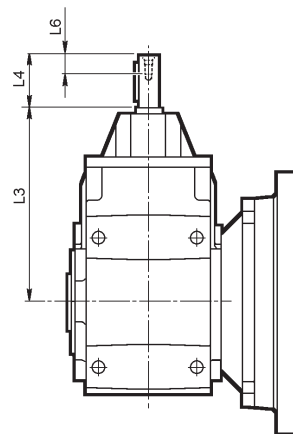
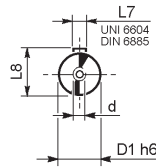
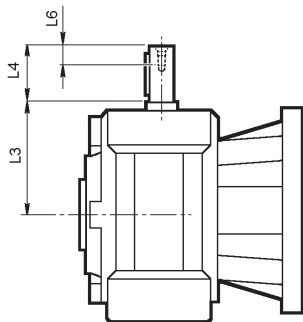
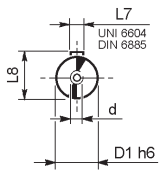

	D1 h6	L3	L4	L6	L7	L8	d
3/V 07L3_HS	25	168	60	19	8	28	M8

	D1 h6	L3	L4	L6	L7	L8	d
3/A 07L2_HS	28	409	60	22	8	31	M10

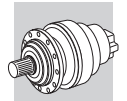

Fattore di posizione per carichi radiali sugli alberi in uscita.

Load location factor for radial loading on output shaft.

Positionsfaktor für Radialkräfte an der Abtriebswelle.

Facteur de position pour charges radiales sur les arbres en sortie.

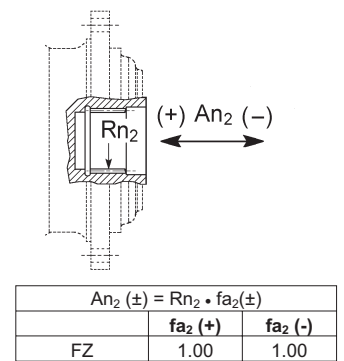
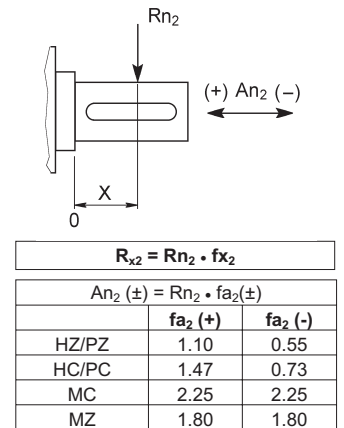
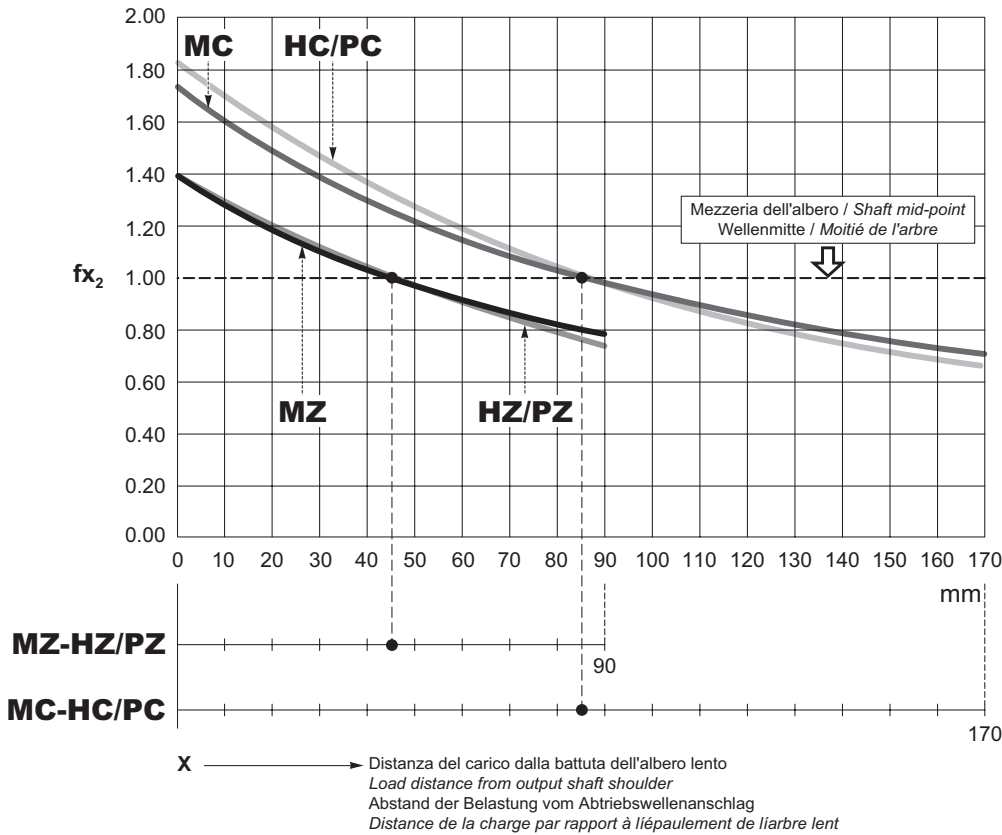

Carichi radiali ammissibili sull'albero veloce per $n_1 = 1000 \text{ min}^{-1}$ e 10000 h di vita teorica. Per velocità di comando e/o durate diverse vedi il capitolo: Verifiche.

Permitted overhung loads on input shaft when $n_1 = 1000 \text{ min}^{-1}$ and theoretical lifetime = 10000 h. For drive speed and/or lifetimes other than those specified here, see Chapter: Verifications.

Zulässige Radialkräfte an den Antriebswellen für $n_1 = 1000 \text{ min}^{-1}$ und 10000 std. Im Hinblick auf Geschwindigkeit und/oder anderweitige Dauern verweisen wir auf Par: Prüfungen

Charges radiales admissibles sur les arbres d'entrée pour $n_1 = 1000 \text{ min}^{-1}$ et 10000 h. Pour des vitesses et/ou durées différentes, voir par. Vérifications.

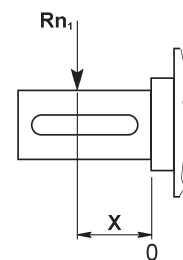
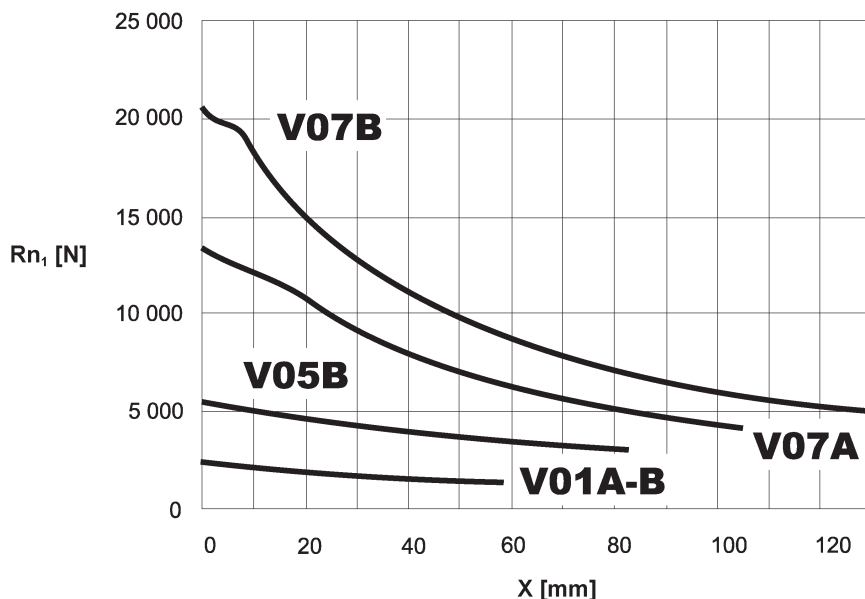

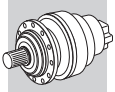

307_VK

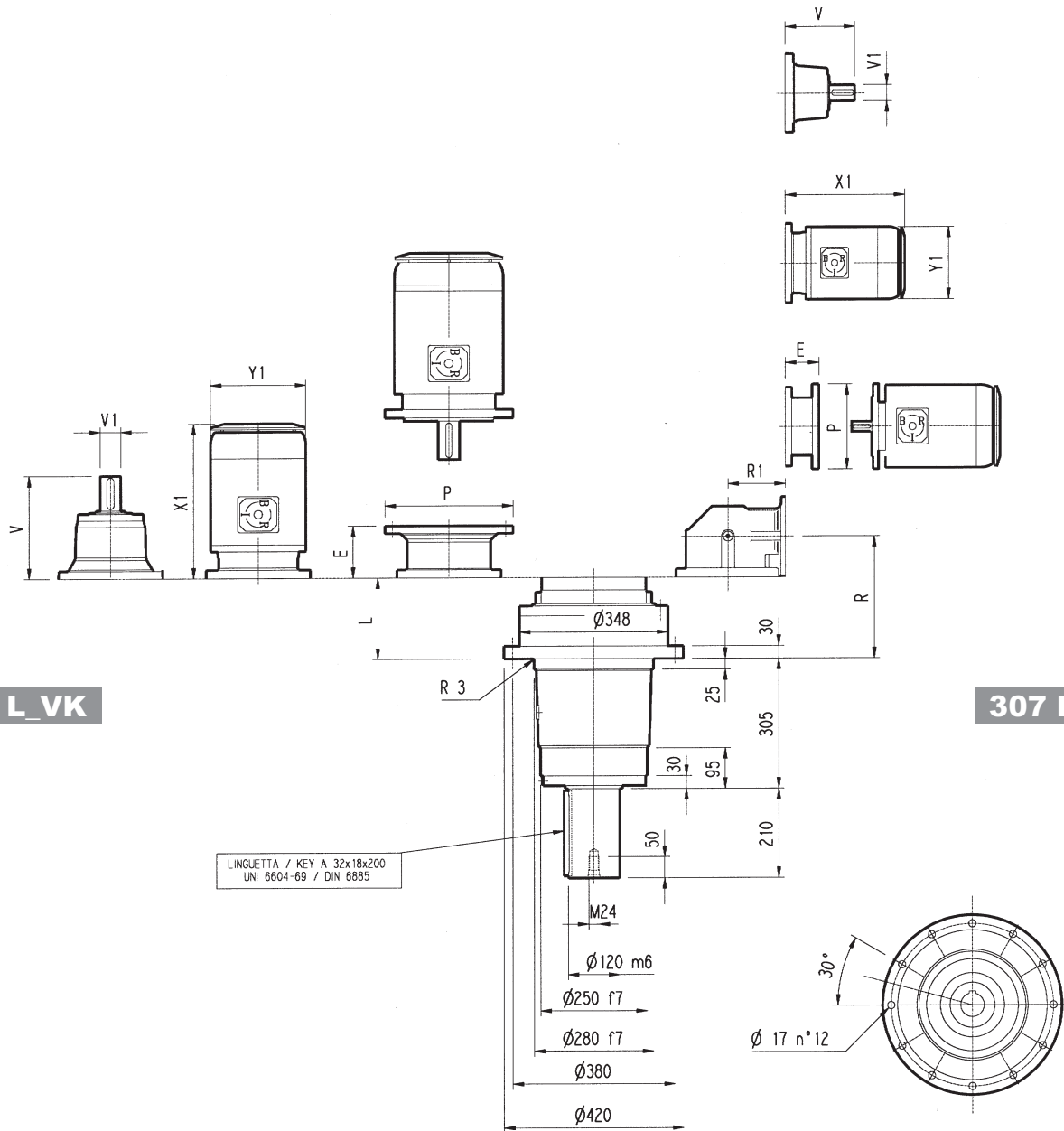

307 L_VK

307 R_VK

	L	Kg	Albero veloce / Input shaft Antriebswelle / Arbre d'entrée							P71		P80		P90		P100		P112		P132		P160		P180		P200L		P225	
			V	V1	Kg	V	V1	Kg	E	P	E	P	E	P	E	P	E	P	E	P	E	P	E	P	E	P	E	P	
			V	V1	Kg	V	V1	Kg	E	P	E	P	E	P	E	P	E	P	E	P	E	P	E	P	E	P	E	P	
307 L1	80	145	315	80	35	313	60	28	-	-	-	-	-	-	-	-	-	-	-	-	-	-	-	195	350	186	400	216	450
307 L2	169	160	239	48	15	-	-	-	-	-	-	-	-	-	-	-	-	-	114	300	144	350	144	350	-	-	-	-	-
307 L3	234	170	137.5	24	6	158	38	7	65	160	84	200	84	200	94	250	94	250	114	300	144	350	-	-	-	-	-	-	-
307 L4	287	175	137.5	24	6	158	38	7	65	160	84	200	84	200	94	250	94	250	114	300	144	350	-	-	-	-	-	-	-

	R	R1	Kg	Albero veloce / Input shaft Antriebswelle / Arbre d'entrée							P71		P80		P90		P100		P112		P132		P160		P180		P200L		
				V	V1	Kg	V	V1	Kg	E	P	E	P	E	P	E	P	E	P	E	P	E	P	E	P	E	P	E	P
				V	V1	Kg	V	V1	Kg	E	P	E	P	E	P	E	P	E	P	E	P	E	P	E	P	E	P	E	P
307 R2	199	225	180	239	48	15	-	-	-	-	-	-	-	-	-	-	-	-	-	114	300	144	350	144	350	144	350	174	400
307 R3	261	140	170	137.5	24	6	158	38	7	65	160	84	200	84	200	94	250	94	250	114	300	144	350	-	-	-	-	-	-
307 R4	326	122	175	137.5	24	6	158	38	7	65	160	84	200	84	200	94	250	94	250	114	300	144	350	-	-	-	-	-	-

	S1 - M1S			S1 - M1L			S2 - M2S			S3 - M3S			S3 - M3L			S4 - M4			S5 - M5S			S5 - M5L		
	X1	X2	Y1	X1	X2	Y1	X1	X2	Y1	X1	X2	Y1	X1	X2	Y1	X1	X2	Y1	X1	X2	Y1	X1	X2	Y1
307 L1	-	-	-	-	-	-	-	-	-	-	-	-	-	-	-	-	-	-	-	-	-	-	-	-
307 L2	-	-	-	-	-	-	-	-	-	-	-	-	-	-	-	460	571	258	552	692	310	596	736	310
307 L3	229	292	138	253	314	138	280	352	156	325	421	195	357	449	195	460	571	258	-	-	-	-	-	-
307 L4	229	292	138	253	314	138	280	352	156	325	421	195	357	449	195	460	571	258	-	-	-	-	-	-

	S1 - M1S			S1 - M1L			S2 - M2S			S3 - M3S			S3 - M3L			S4 - M4			S5 - M5S			S5 - M5L		
	X1	X2	Y1	X1	X2	Y1	X1	X2	Y1	X1	X2	Y1	X1	X2	Y1	X1	X2	Y1	X1	X2	Y1	X1	X2	Y1
307 R2	-	-	-	-	-	-	-	-	-	-	-	-	-	-	-	508	619	258	552	692	310	596	736	310
307 R3	229	292	138	253	314	138	328	400	156	373	469	195	405	497	195	508	619	258	-	-	-	-	-	-
307 R4	229	292	138	253	314	138	328	400	156	373	469	195	405	497	195	508	619	258	-	-	-	-	-	-

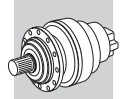

Il diagramma seguente consente di ricavare il carico radiale ammissibile R_{x2} quando questo è applicato alla distanza x dallo spallamento dell'albero lento del riduttore 307_VK.

Le curve si riferiscono al valore risultante dal rapporto fra il carico assiale A_{n2} e il carico radiale R_{n2} , entrambi riferiti a $n_2 = 10 \text{ min}^{-1}$ e durata teorica di 10000 h.

The diagram below allows the calculation of permitted overhung load R_{x2} on the output shaft of gearbox type 307_VK, with radial force applying at a distance x from shaft shoulder.

The curves are relevant to value resulting from the relationship of trust load A_{n2} to radial load R_{n2} , based on $n_2 = 10 \text{ min}^{-1}$ and 10000 hrs theoretical lifetime.

Das nachstehende Diagramm ermöglicht das Individuieren der zulässigen, auf die Welle des Getriebes 307_VK einwirkenden Radialkraft, die auf der Distanz x vom Anschlag der Welle selbst appliziert wird.

Die Kurven beziehen sich auf den Wert, der sich aus dem Verhältnis zwischen der Axialkraft A_{n2} und der Radialkraft R_{n2} für $n_2 = 10 \text{ min}^{-1}$ und einer Dauer von 10000 Std. ergibt.

Le diagramme suivant permet de déterminer la charge radiale admissible R_{x2} sur l'arbre lent du réducteur 307_VK appliqué à la distance x de l'épaule de l'arbre.

Les courbes se réfèrent à la valeur résultant de l'équation entre la charge axiale A_{n2} et la charge radiale R_{n2} pour $n_2 = 10 \text{ min}^{-1}$ et durée de 10000 h.

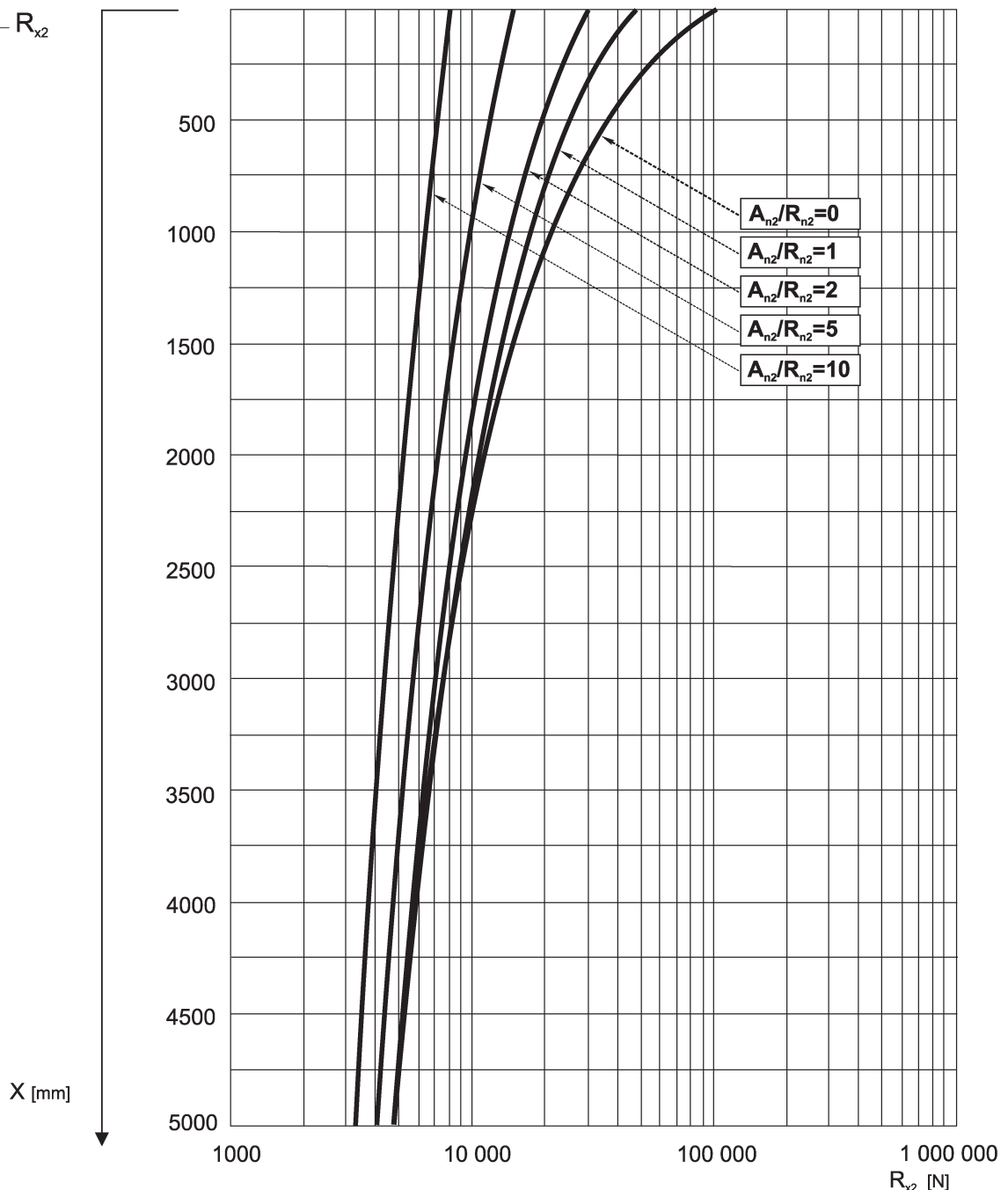
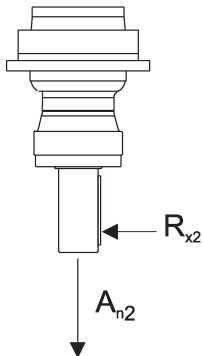

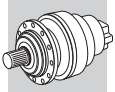

309 L

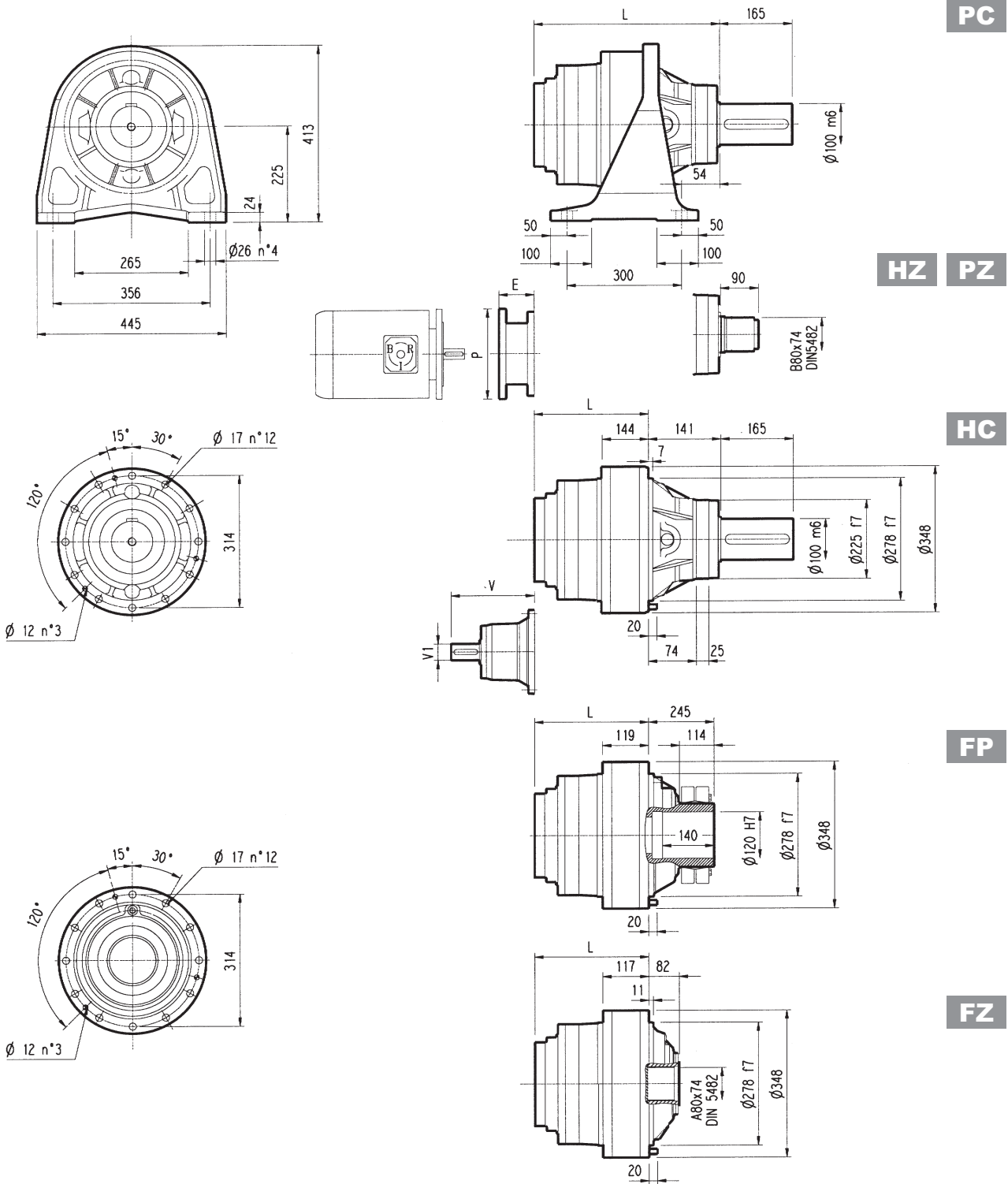

FP

$M_{2max} = 25\,000\text{ Nm}$

	L				$\overset{\text{Kg}}{\text{kg}}$				Albero veloce / Input shaft / Antriebswelle / Arbre d'entrée					
	PC - PZ	HC - HZ	FZ	FP	PC - PZ	HC - HZ	FZ	FP	V	V1	$\overset{\text{Kg}}{\text{kg}}$	V	V1	$\overset{\text{Kg}}{\text{kg}}$
309 L1	267	126	99	101	130	115	95	100	315	80	35	313	60	28
309 L2	356	215	188	190	142	127	107	112	239	48	15	-	-	-
309 L3	421	280	253	255	149	134	114	119	137.5	24	6	158	38	7
309 L4	474	333	306	308	153	138	118	123	137.5	24	6	158	38	7

	P71		P80		P90		P100		P112		P132		P160		P180		P200		P225		P250	
	E	P	E	P	E	P	E	P	E	P	E	P	E	P	E	P	E	P	E	P	E	P
309 L1	-	-	-	-	-	-	-	-	-	-	-	-	-	-	195	350	186	400	216	450	216	550
309 L2	-	-	-	-	-	-	-	-	-	-	114	300	144	350	144	350	-	-	-	-	-	-
309 L3	65	160	84	200	84	200	94	250	94	250	114	300	144	350	-	-	-	-	-	-	-	-
309 L4	65	160	84	200	84	200	94	250	94	250	114	300	144	350	-	-	-	-	-	-	-	-

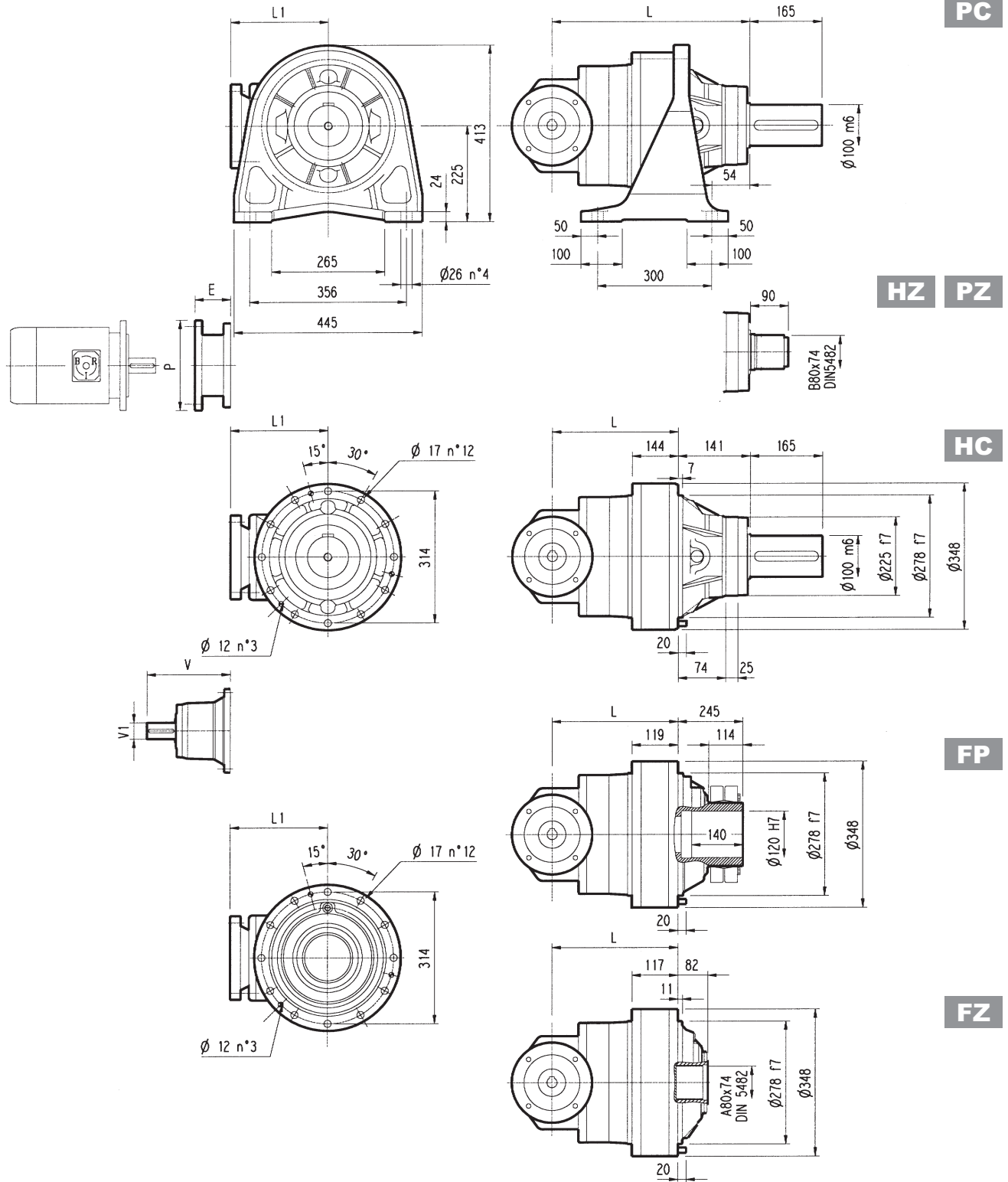
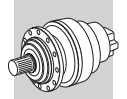

FP $M_{2max} = 25\,000\text{ Nm}$

	L				L1	Kg				Albero veloce / Input shaft / Antriebswelle / Arbre d'entrée					
	PC - PZ	HC - HZ	FZ	FP		PC - PZ	HC - HZ	FZ	FP	V	V1	Kg	V	V1	Kg
309 R2	386	245	218	220	225	180	165	145	150	239	48	15	-	-	-
309 R3	448	307	280	282	140	162	147	127	132	137.5	24	6	158	38	7
309 R4	513	372	345	347	122	163	148	128	133	137.5	24	6	158	38	7

	P71		P80		P90		P100		P112		P132		P160M		P180		P200L	
	E	P	E	P	E	P	E	P	E	P	E	P	E	P	E	P	E	P
309 R2	-	-	-	-	-	-	-	-	-	-	114	300	144	350	144	350	174	400
309 R3	65	160	84	200	84	200	94	250	94	250	114	300	144	350	-	-	-	-
309 R4	65	160	84	200	84	200	94	250	94	250	114	300	-	-	-	-	-	-

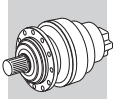

3/V 09L3

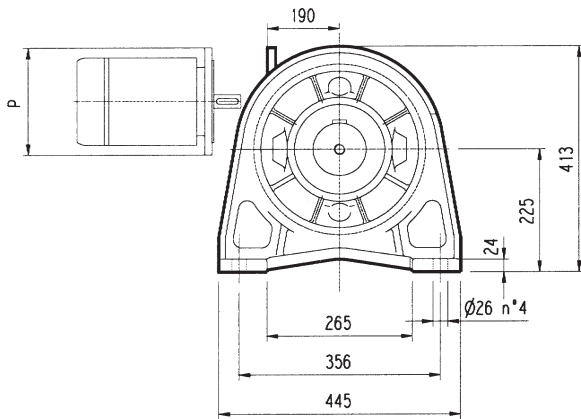

PC

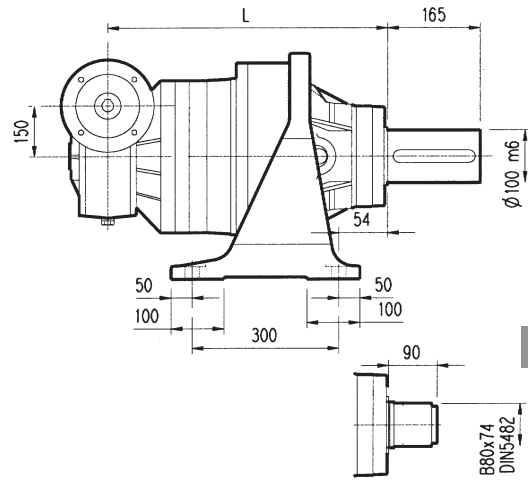

HZ PZ

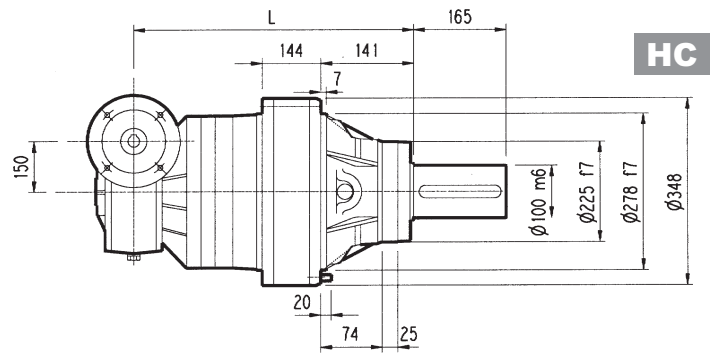
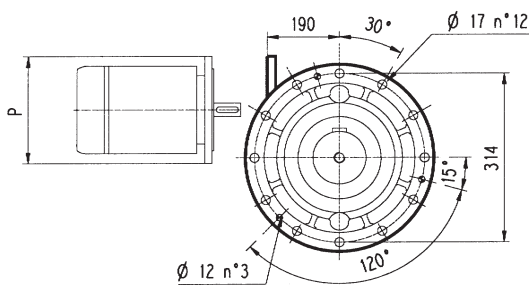

HC

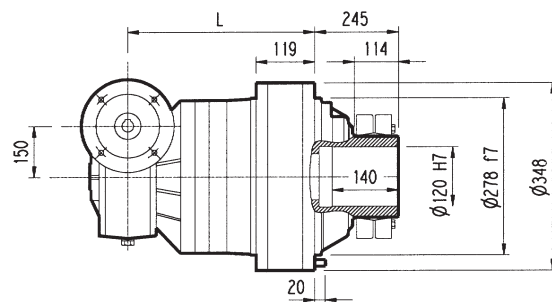
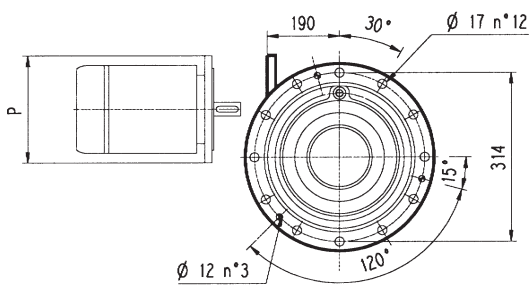
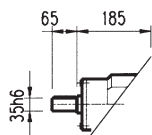

FP

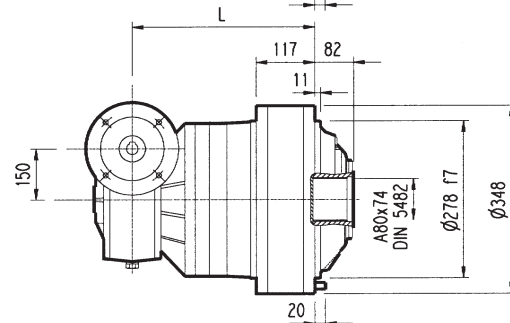

FZ

FP $M_{2max} = 25\,000\text{ Nm}$

	L				Kg				P100	P112	P132	P160
	PC - PZ	HC - HZ	FZ	FP	PC - PZ	HC - HZ	FZ	FP	P	P	P	P
3/V 09L3	530	389	362	364	202	187	167	172	250	250	300	350

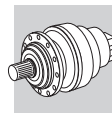

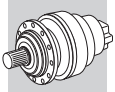

309 L

309 R

3/V 09L3

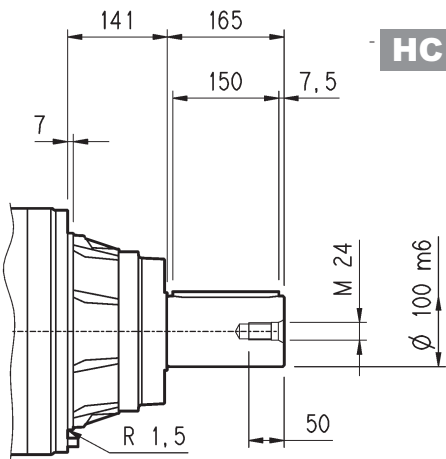

HC

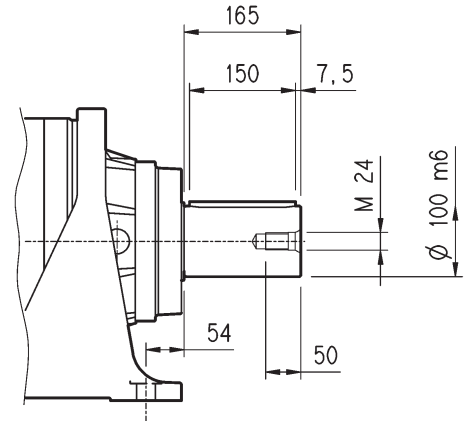
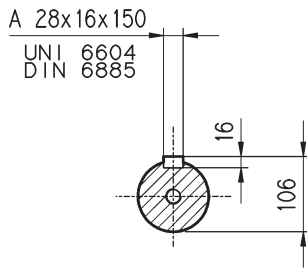

PC

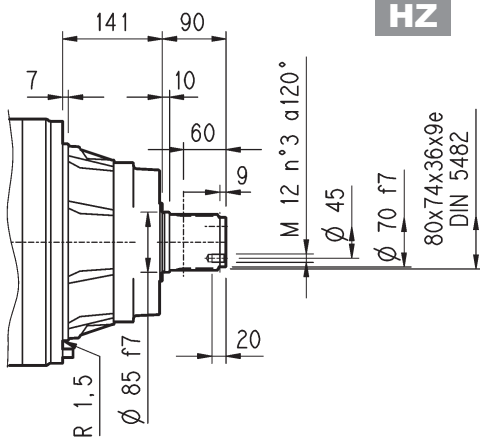

HZ

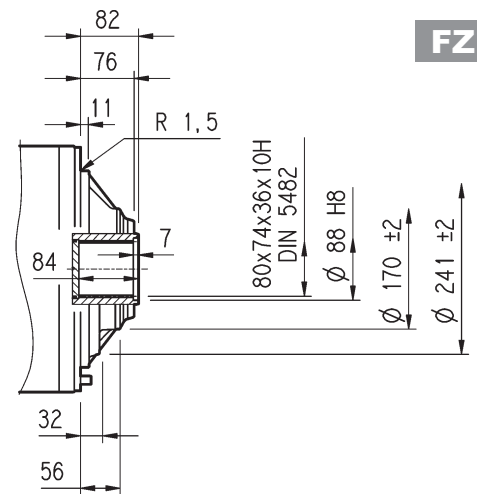
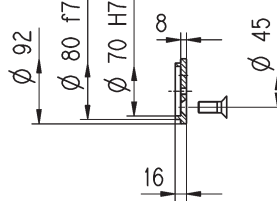

FZ

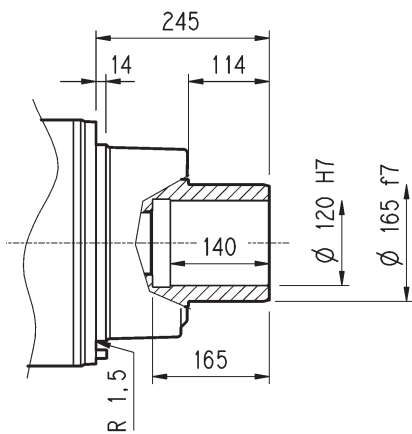

FP

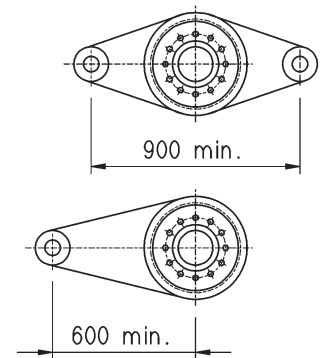
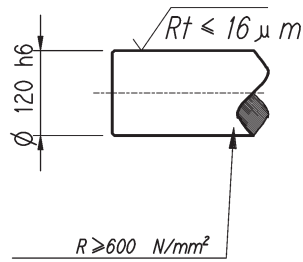

FP

$M_{2max} = 25\,000\text{ Nm}$

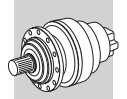
Flangia / Flange
Flansch / Brides

W0A

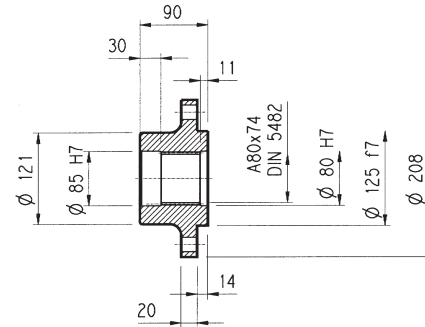
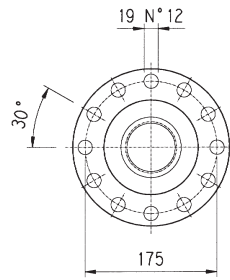
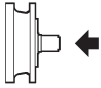

Materiale : Acciaio C40
 Material : Steel C40
 Material : Stahl C40
 Matière : Acier C40

Pignoni / Pinion gears
Ritzel / Pignons

P...

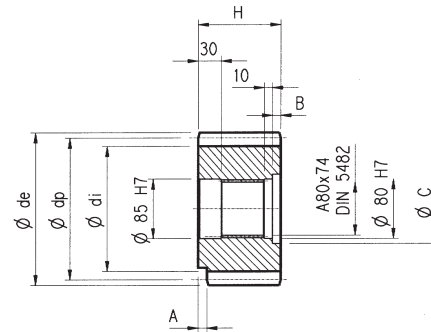
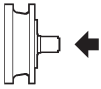

	m	z	x	dp	di	de	H	A	B	C	☆
PFG	8	16	0.500	128	117	149.5	90	0	0	0	□
PHC	10	12	0.450	120	104	145	90	0	0	0	□
PHE	10	14	0.320	140	121	162.5	116	13	26	95	□
PHF	10	15	0.150	150	130	171.5	107	20	17	100	□
PHG	10	16	0.500	160	145	186	90	0	0	0	■
PHH1	10	17	0	170	145	190	90	0	0	0	■
PHH2	10	17	0.500	170	154	198	90	0	0	0	■
PLD	12	13	0.500	156	138	192	102	0	12	95	□
PLE	12	14	0.500	168	150	199.2	90	0	0	0	□
PLI	12	18	0.500	216	198	249.6	107	7	17	95	□
PLT	12	26	0	312	282	336	90	10	0	0	■

☆	Materiale / Material / Material / Matière
□	Acciaio 39NiCrMo3 Bonificato Steel 39NiCrMo3 hardened and tempered Vergüteter Stahl 39NiCrMo3 Acier bonifiée 39NiCrMo3
■	Acciaio 18NiCrMo5 Cementato e temprato Steel 18NiCrMo5 Case hardened Einsatzstahl 18NiCrMo5 Einsatzgehärtet Acier cimenté et tempré 18NiCrMo5

Manicotti lisci / Sleeve couplings
Naben / Manchons lisses a cannelure interieure

MOA

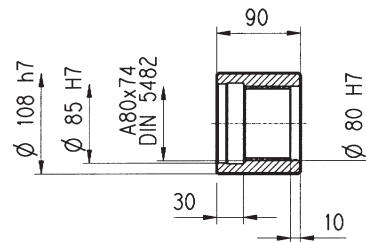
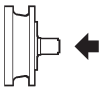

Materiale : Acciaio 16CrNi4
 Material : Steel 16CrNi4
 Material : Stahl 16CrNi4
 Matière : Acier 16CrNi4

Barre scanalate / Splined bars
Vielkeilwellen / Barre cannelée

B0A

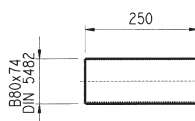
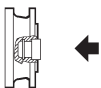

Mat. acciaio 18NiCrMo5 UNI 5331 da cementare e temprare 50-55 HRC
 Case hardening steel 18NiCrMo5 UNI 5331 must be case hardened 50-55 HRC
 Material: Einsatzstahl 18NiCrMo5 UNI 5331 muss einsatzgehärtet werden 50-55 HRC
 Acier 18 NiCrMo5 UNI 5331 doit être cimenté trempé 50-55 HRC

Giunto ad attrito / Shrink disc
Schrumpfscheibe / Frette de serrage

GOA

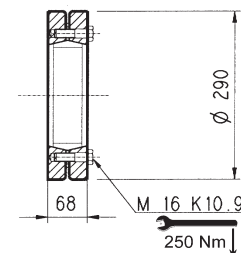
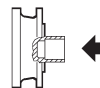

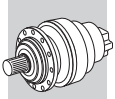

309 L

309 R

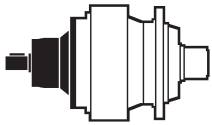
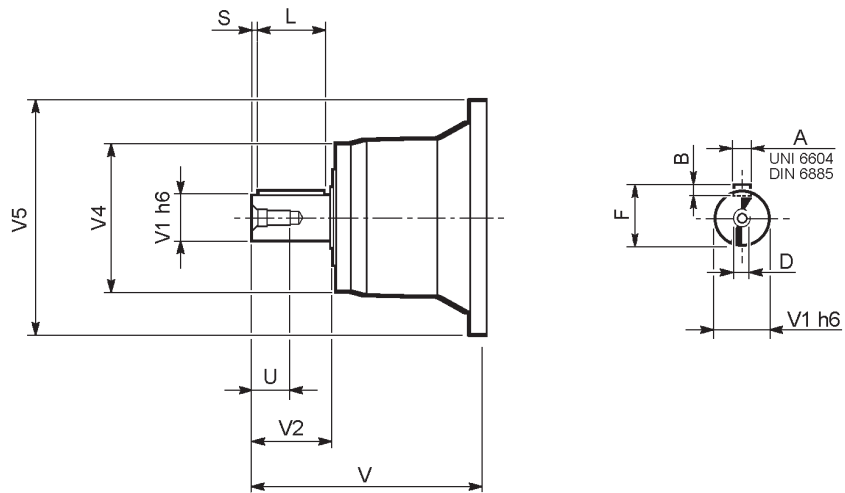

	CODE	V	V1	V2	V4	V5	A	B	F	L	S	D	U
309 L1	V07B	315	80	130	200	345	22	14	85	110	10	M16	36
	V07A	313	60	105	155	345	18	11	64	90	7.5	M16	36
309 L2	V05B	239	48	82	155	245	14	9	51.5	70	6	M16	36
309 L3	V01A	137.5	24	36	120	186	8	7	27	30	3	M8	19
	V01B	158	38	58	120	186	10	8	41	50	4	M12	28
309 L4	V01A	137.5	24	36	120	186	8	7	27	30	3	M8	19
	V01B	158	38	58	120	186	10	8	41	50	4	M12	28
309 R2	V05B	239	48	82	155	245	14	9	51.5	70	6	M16	36
309 R3-R4	V01A	137.5	24	36	120	186	8	7	27	30	3	M8	19
	V01B	158	38	58	120	186	10	8	41	50	4	M12	28

3/V 09L3

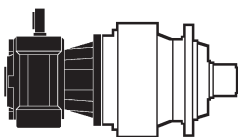
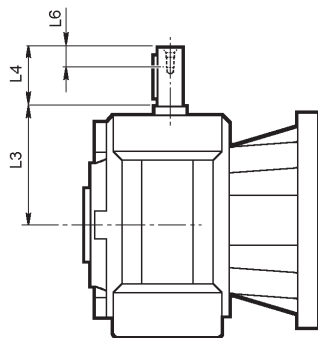
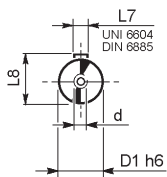

	D1 h6	L3	L4	L6	L7	L8	d
3/V 09L3_HS	35	185	65	20	10	38	M8

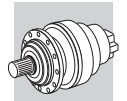

Fattore di posizione per carichi radiali sugli alberi in uscita.

Load location factor for radial loading on output shaft.

Positionsfaktor für Radialkräfte an der Abtriebswelle.

Facteur de position pour charges radiales sur les arbres en sortie.

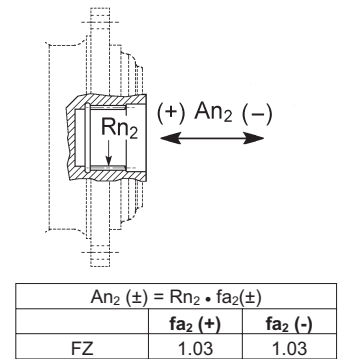
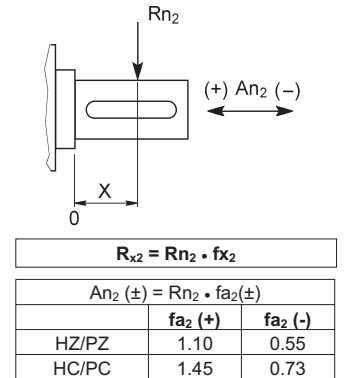
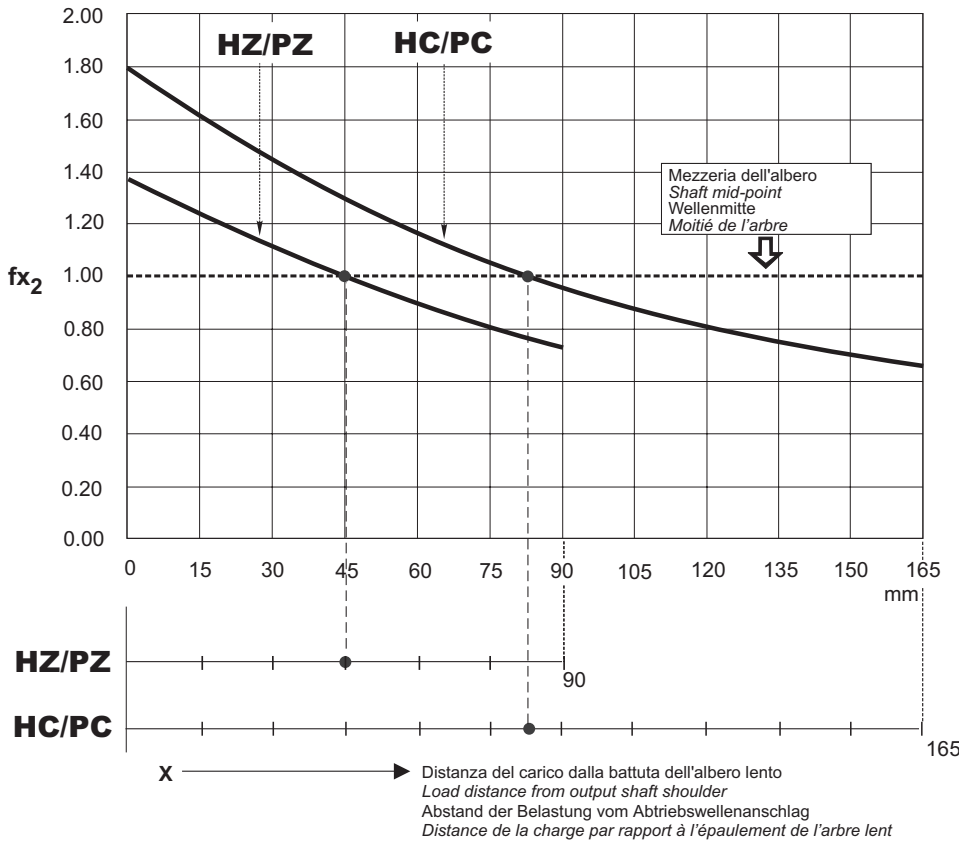

Carichi radiali ammissibili sull'albero veloce per n₁ = 1000 min⁻¹ e 10000 h di vita teorica.
Per velocità di comando e/o durate diverse vedi il capitolo: Verifiche.

Permitted overhung loads on input shaft when n₁ = 1000 min⁻¹ and theoretical lifetime = 10000 h.
For drive speed and/or lifetimes other than those specified here, see Chapter: Verifications.

Zulässige Radialkräfte an den Antriebswellen für n₁ = 1000 min⁻¹ und 10000 std.
Im Hinblick auf Geschwindigkeit und/oder anderweitige Dauerverweisen wir auf Par: Prüfungen

Charges radiales admissibles sur les arbres d'entrée pour n₁ = 1000 min⁻¹ et 10000 h.
Pour des vitesses et/ou durées différentes, voir par. Vérifications.

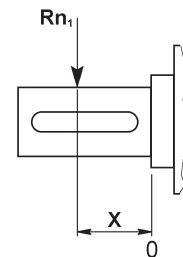
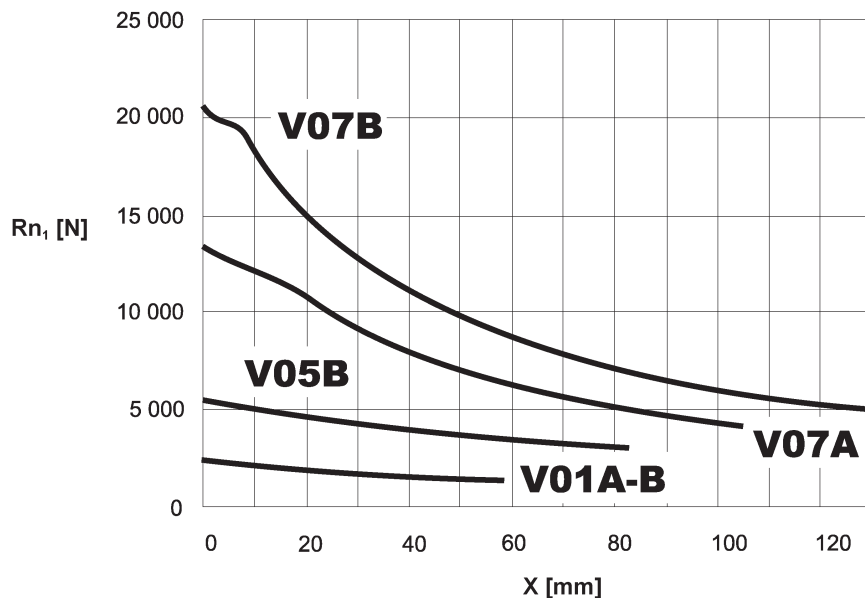

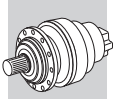

309_VK

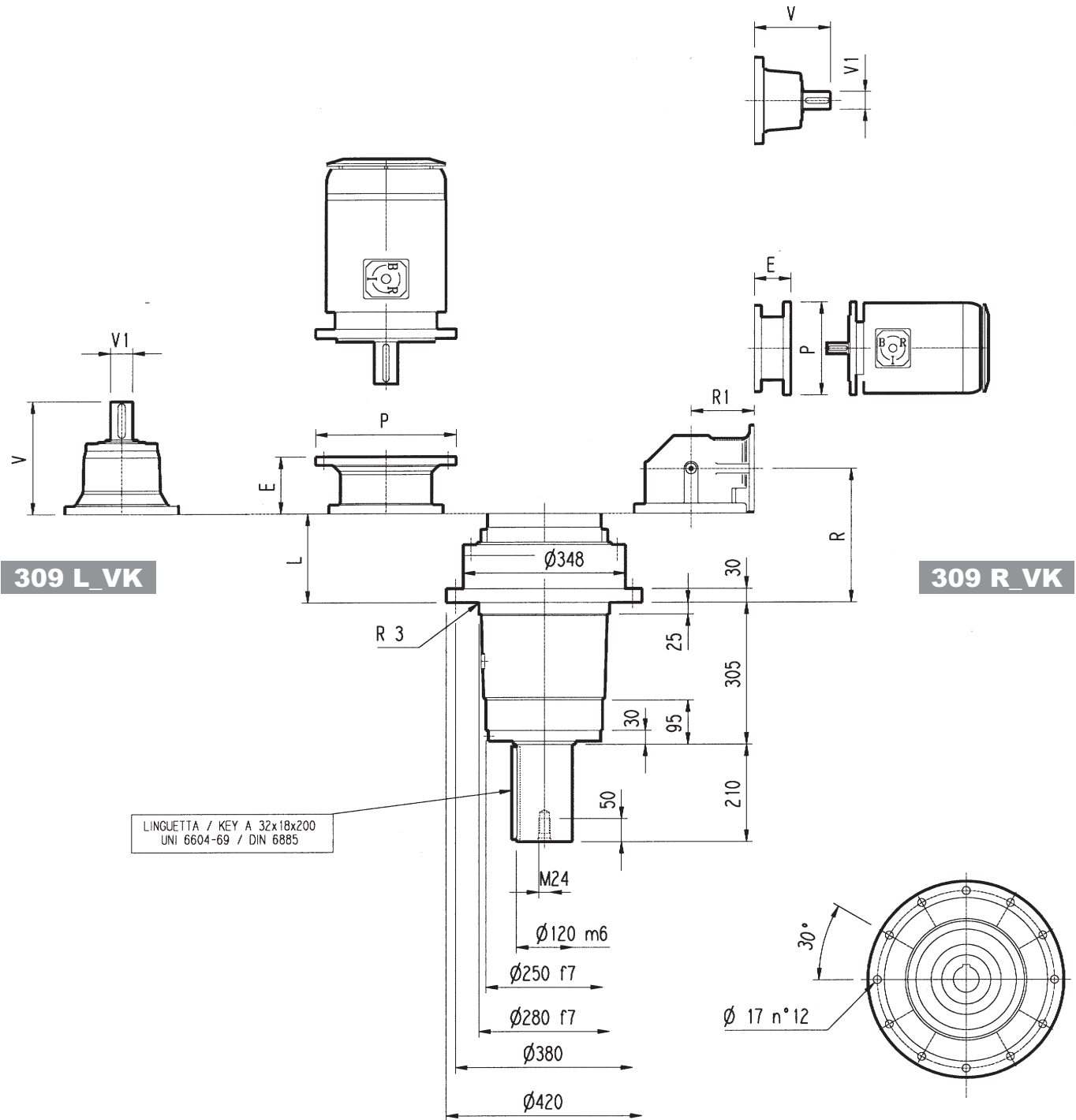

309 L_VK

309 R_VK

LINGUETTA / KEY A 32x18x200
UNI 6604-69 / DIN 6885

	L	Albero veloce / Input shaft Antriebswelle / Arbre d'entrée								P71		P80		P90		P100		P112		P132		P160		P180		P200L		P225	
		V	V1	kg	V	V1	kg	E	P	E	P	E	P	E	P	E	P	E	P	E	P	E	P	E	P	E	P		
309 L1	102	165	315	80	35	313	60	28	-	-	-	-	-	-	-	-	-	-	-	-	-	-	195	350	186	400	216	450	
309 L2	191	180	239	48	15	-	-	-	-	-	-	-	-	-	-	-	-	-	114	300	144	350	144	350	-	-	-	-	
309 L3	256	190	137.5	24	6	158	38	7	65	160	84	200	84	200	94	250	94	250	114	300	144	350	-	-	-	-	-	-	
309 L4	309	195	137.5	24	6	158	38	7	65	160	84	200	84	200	94	250	94	250	114	300	144	350	-	-	-	-	-	-	

	R	R1	Albero veloce / Input shaft Antriebswelle / Arbre d'entrée								P71		P80		P90		P100		P112		P132		P160		P180		P200L	
			V	V1	kg	V	V1	kg	E	P	E	P	E	P	E	P	E	P	E	P	E	P	E	P	E	P		
309 R2	221	225	200	239	48	15	-	-	-	-	-	-	-	-	-	-	-	-	-	-	114	300	144	350	144	350	174	400
309 R3	283	140	190	137.5	24	6	158	38	7	65	160	84	200	84	200	94	250	94	250	114	300	144	350	-	-	-	-	-
309 R4	348	122	195	137.5	24	6	158	38	7	65	160	84	200	84	200	94	250	94	250	114	300	-	-	-	-	-	-	-

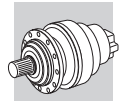

Il diagramma seguente consente di ricavare il carico radiale ammissibile R_{x2} quando questo è applicato alla distanza x dallo spallamento dell'albero lento del riduttore 309_VK.

Le curve si riferiscono al valore risultante dal rapporto fra il carico assiale A_{n2} e il carico radiale R_{n2} , entrambi riferiti a $n_2 = 10 \text{ min}^{-1}$ e durata teorica di 10000 h.

The diagram below allows the calculation of permitted overhung load R_{x2} on the output shaft of gearbox type 309_VK, with radial force applying at a distance x from shaft shoulder.

The curves are relevant to value resulting from the relationship of trust load A_{n2} to radial load R_{n2} , based on $n_2 = 10 \text{ min}^{-1}$ and 10000 hrs theoretical lifetime.

Das nachstehende Diagramm ermöglicht das Individuieren der zulässigen, auf die Welle des Getriebes 309_VK einwirkenden Radialkraft, die auf der Distanz x vom Anschlag der Welle selbst appliziert wird.

Die Kurven beziehen sich auf den Wert, der sich aus dem Verhältnis zwischen der Axialkraft A_{n2} und der Radialkraft R_{n2} für $n_2 = 10 \text{ min}^{-1}$ und einer Dauer von 10000 Std. ergibt.

Le diagramme suivant permet de déterminer la charge radiale admissible R_{x2} sur l'arbre lent du réducteur 309_VK appliqué à la distance x de l'épaule de l'arbre.

Les courbes se réfèrent à la valeur résultant de l'équation entre la charge axiale A_{n2} et la charge radiale R_{n2} pour $n_2 = 10 \text{ min}^{-1}$ et durée de 10000 h.

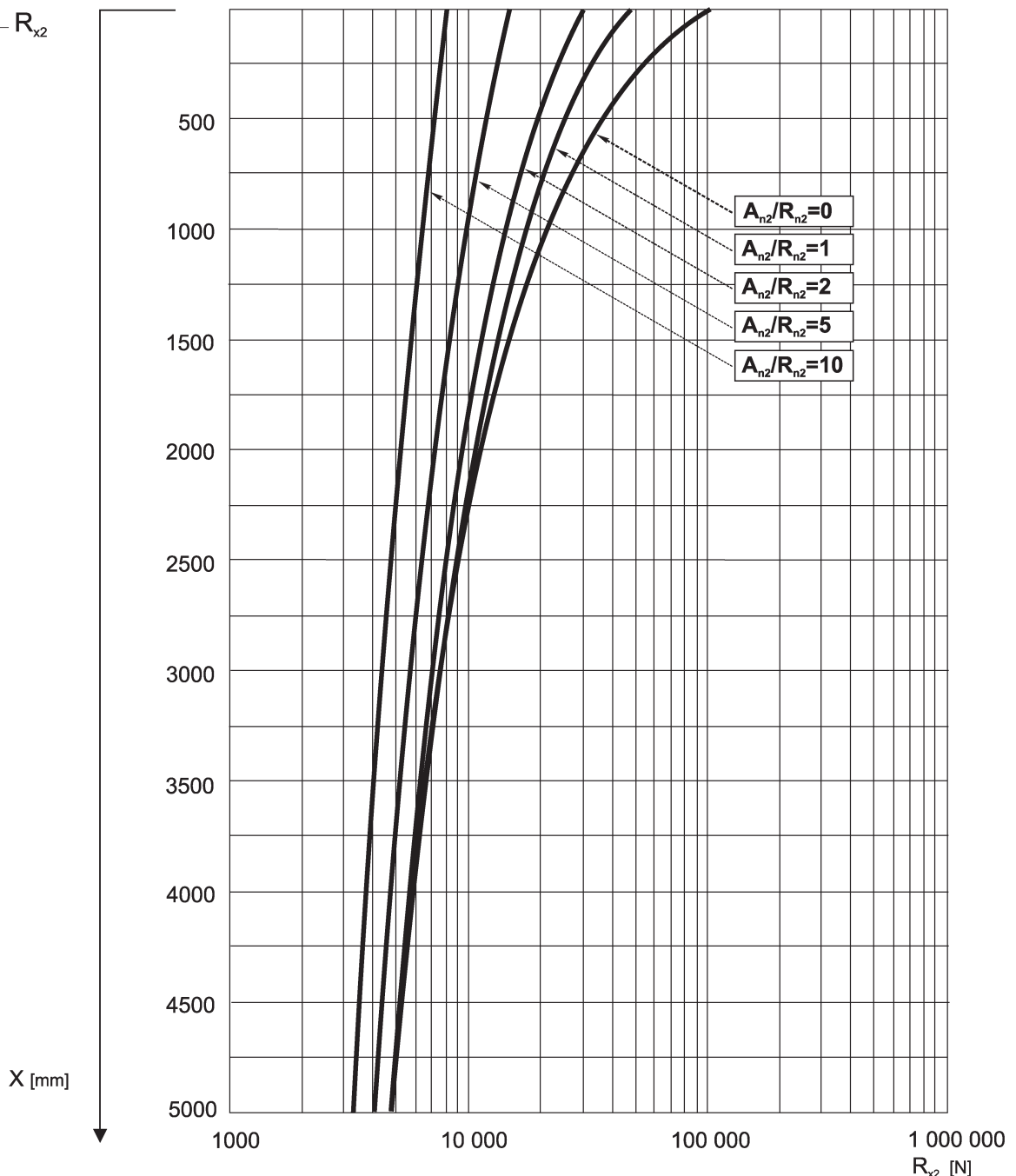
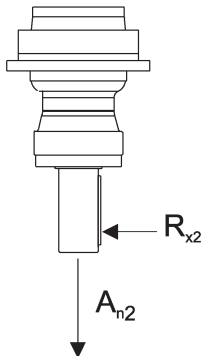

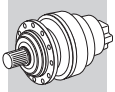

310 L

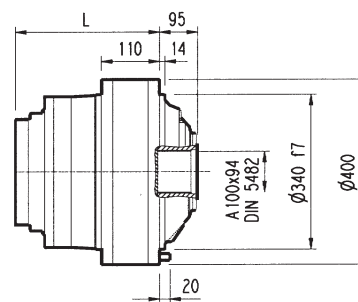
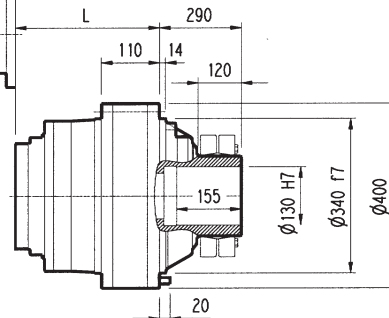
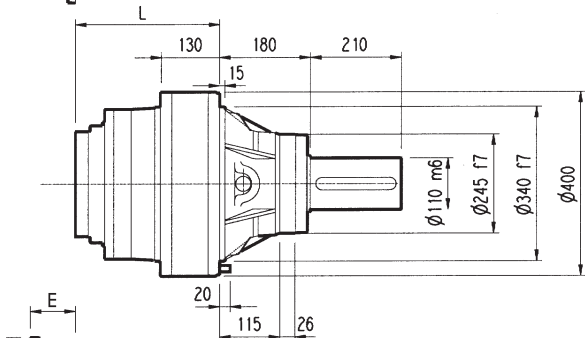
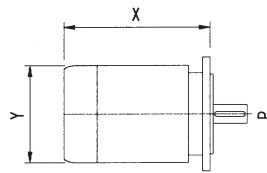
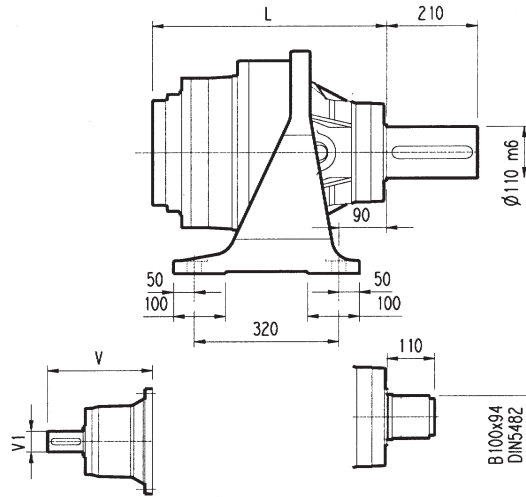
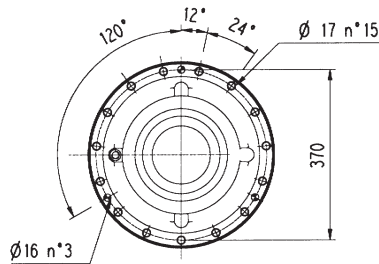
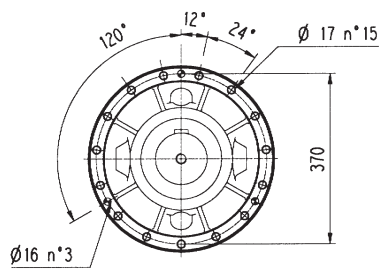
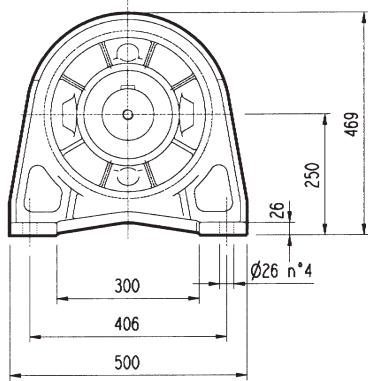

PC

HZ PZ

HC

FP

FZ

FP

$M_{2max} = 36\ 000\ Nm$

	L				Kg				Albero veloce / Input shaft / Antriebswelle / Arbre d'entrée					
	PC - PZ	HC - HZ	FZ	FP	PC - PZ	HC - HZ	FZ	FP	V	V1	Kg	V	V1	Kg
310 L1	288	108	88	88	155	135	110	115	377	80	50	-	-	-
310 L2	424	244	224	224	185	165	140	145	307	60	23	-	-	-
310 L3	489	309	289	289	194	174	149	154	239	48	15	-	-	-
310 L4	542	362	342	342	198	178	153	158	137.5	24	6	158	38	7

	P71		P80		P90		P100		P112		P132		P160		P180		P200L		P225		P250M	
	E	P	E	P	E	P	E	P	E	P	E	P	E	P	E	P	E	P	E	P	E	P
310 L1	-	-	-	-	-	-	-	-	-	-	-	-	-	-	-	-	271	400	301	450	281	550
310 L2	-	-	-	-	-	-	-	-	-	-	-	-	152	350	153	350	183	400	212	450	-	-
310 L3	-	-	-	-	-	-	-	-	-	-	114	300	144	350	144	350	-	-	-	-	-	-
310 L4	65	160	84	200	84	200	94	250	94	250	114	300	144	350	-	-	-	-	-	-	-	-

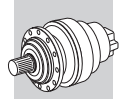

PC

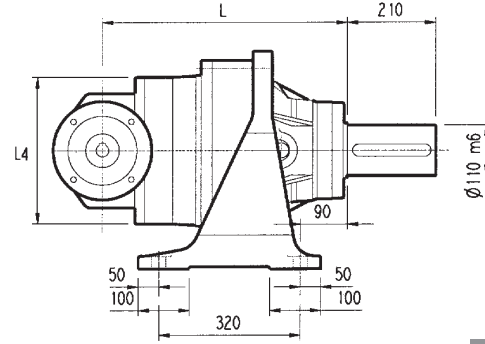
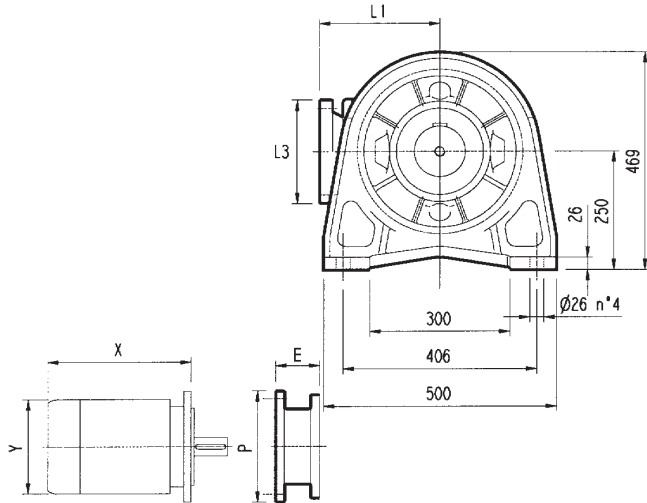

HZ PZ

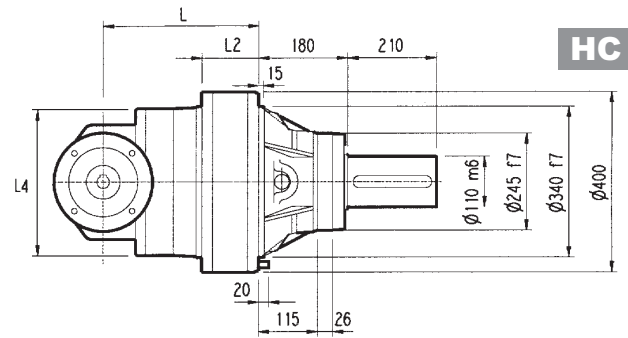
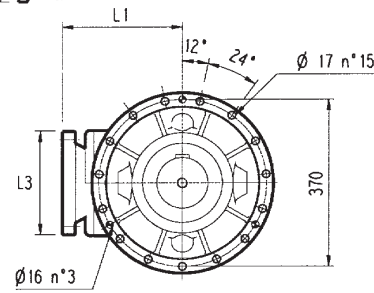
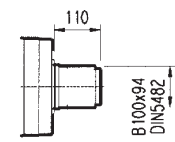

HC

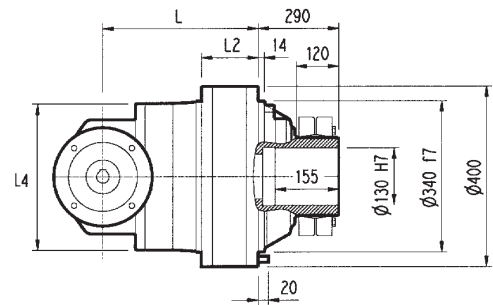
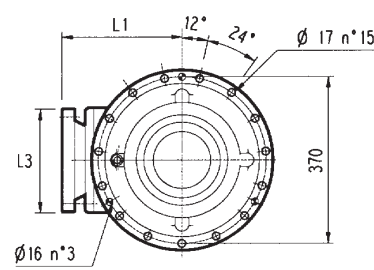
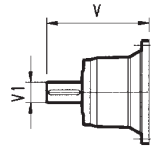

FP

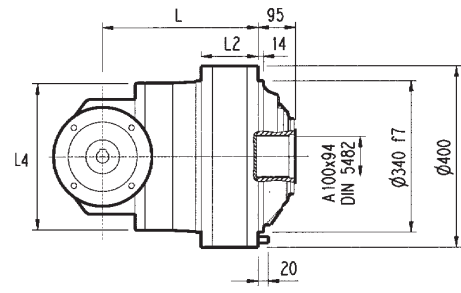

FZ

FP $M_{2max} = 36\ 000\ Nm$

	L				L1	L2				L3	L4	Albero veloce / Input shaft Antriebswelle / Arbre d'entrée									
	PC - PZ	HC - HZ	FZ	FP		PC - PZ	HZ - HC	FZ	FP			Kg				V					
	PC - PZ	HC - HZ	FZ	FP		PC - PZ	HZ - HC	FZ	FP			PC - PZ	HC - HZ	FZ	FP	V	V1	Kg	V	V1	Kg
310 R2 (B)	485	305	285	285	345	-	198	178	178	292	400	280	260	240	250	307	60	23			
310 R2 (A)	465	285	265	265	330	-	178	158	158	245	345	260	240	220	230	239	48	15			
310 R3	561	381	361	361	140	-	130	110	110	186	244	209	189	164	169	137.5	24	6	158	38	7
310 R4	581	401	381	381	140	-	130	110	110	186	244	214	194	169	174	137.5	24	6	158	38	7

	P71		P80		P90		P100		P112		P132		P160M		P180		P200L		P225	
	E	P	E	P	E	P	E	P	E	P	E	P	E	P	E	P	E	P	E	P
310 R2 (B)	-	-	-	-	-	-	-	-	-	-	-	-	-	-	152	350	182	400	212	450
310 R2 (A)	-	-	-	-	-	-	-	-	-	-	114	300	152	350	144	350	174	400	174	450
310 R3	65	160	84	200	84	200	94	250	94	250	114	300	144	350	-	-	-	-	-	-
310 R4	65	160	84	200	84	200	94	250	94	250	114	300	144	350	-	-	-	-	-	-

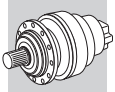

3/V 10L3

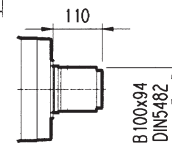
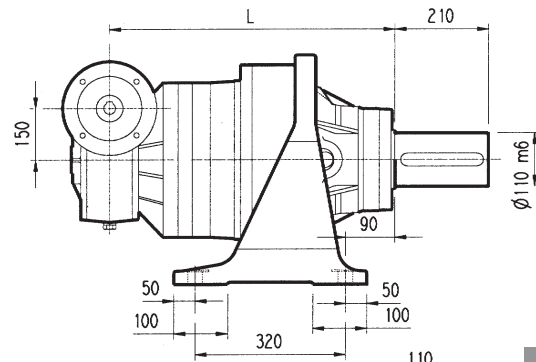
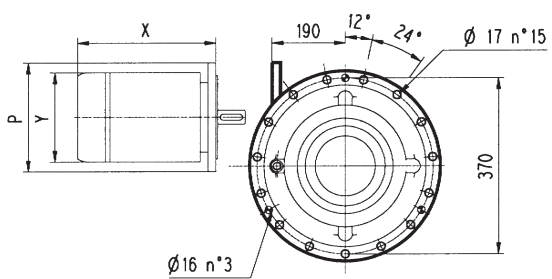
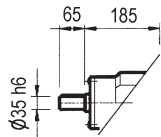
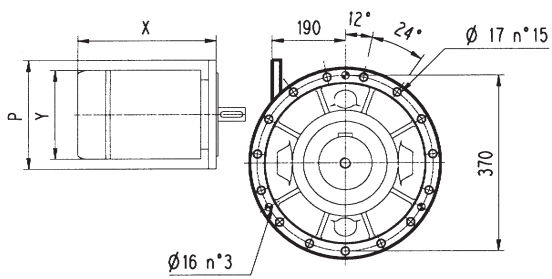
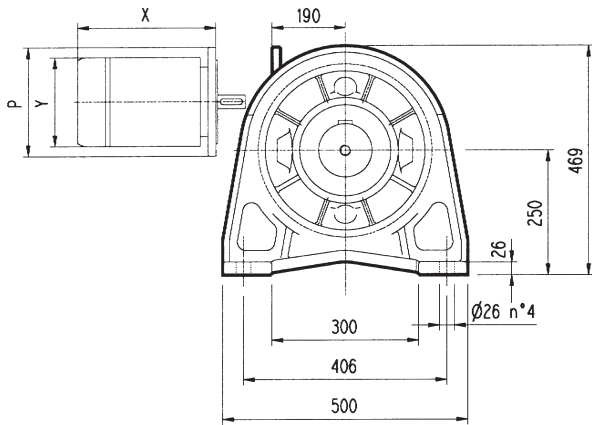

PC

HZ PZ

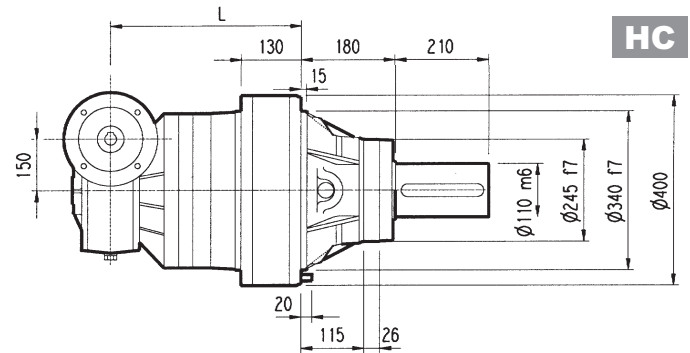

HC

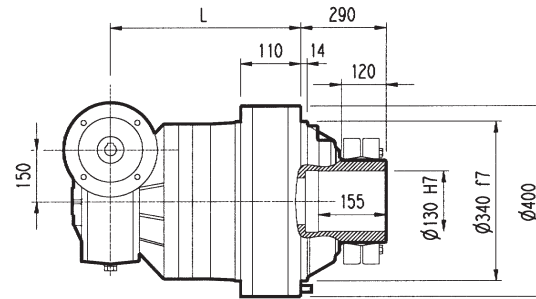

FP

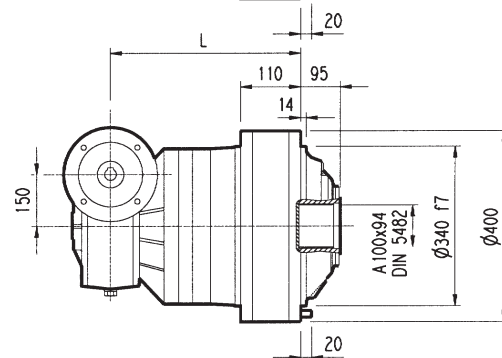

FZ

FP

$M_{2max} = 36\ 000\ Nm$

	L				kg				P71	P80	P90	P100	P112	P132	P160
	PC - PZ	HC - HZ	FZ	FP	PC - PZ	HC - HZ	FZ	FP							
3/V 10L3	608	428	408	408	245	225	200	205	-	-	-	250	250	300	300

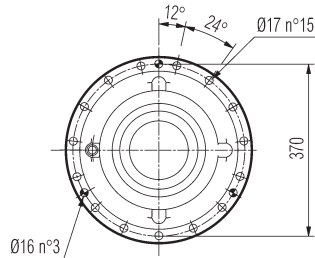
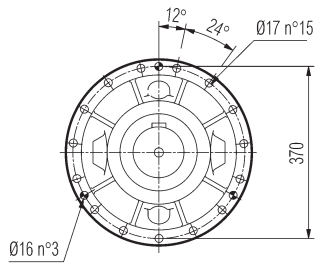
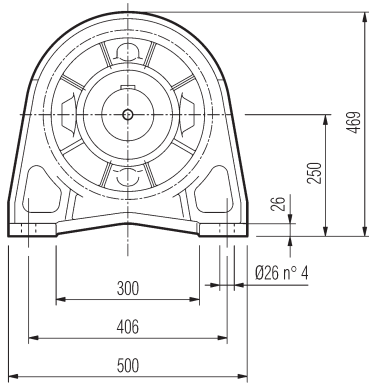
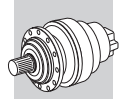

VISTA DA A
VIEW FROM A

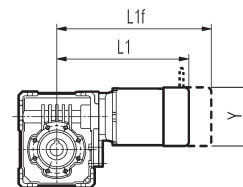
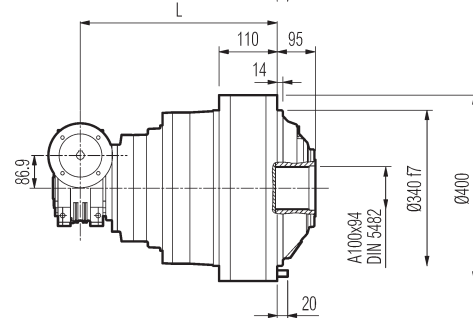
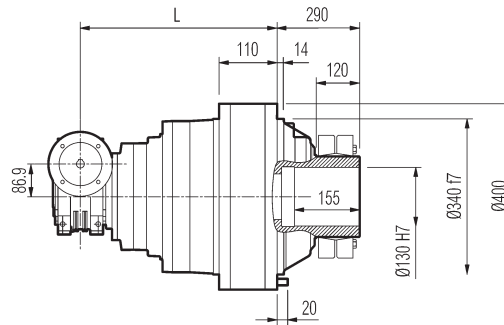
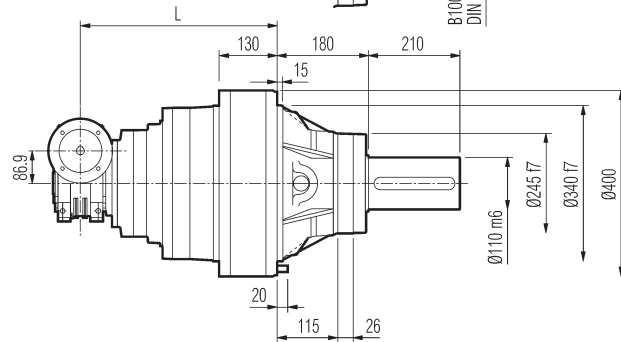
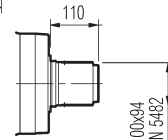
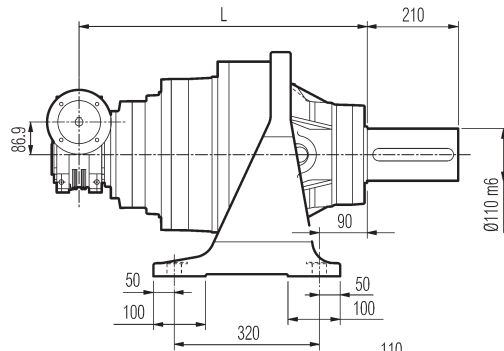
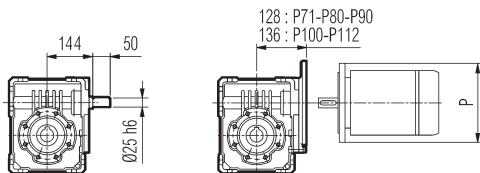

PC

HZ PZ

HC

FP

FZ

FP

$M_{2max} = 36\ 000\ Nm$

3/V 10L4	L								Kg											
	PC - PZ		HC - HZ		FZ		FP		PC - PZ		HC - HZ		FZ		FP					
	634		454			434		434	210		190		165		170					
3/V 10L4	P71	P80	P90	P100	P112	S1 - M1S			S1 - M1L			S2 - M2S			S3 - M3S			S3 - M3L		
	P	P	P	P	P	L1	L1f	Y	L1	L1f	Y	L1	L1f	Y	L1	L1f	Y	L1	L1f	Y
	160	200	200	250	250	300	363	138	324	385	138	349	425	156	392	477	193	424	515	193

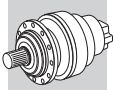

310 L

310 R

3/V 10L3

3/V 10L4

HC

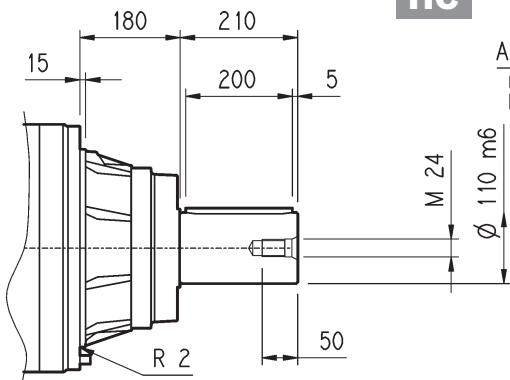

A 28x16x200
UNI 6604
DIN 6885

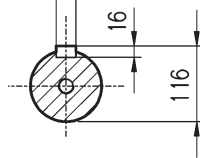

PC

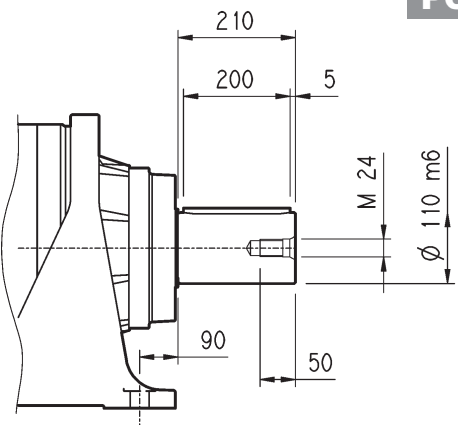

HZ

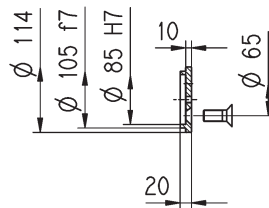
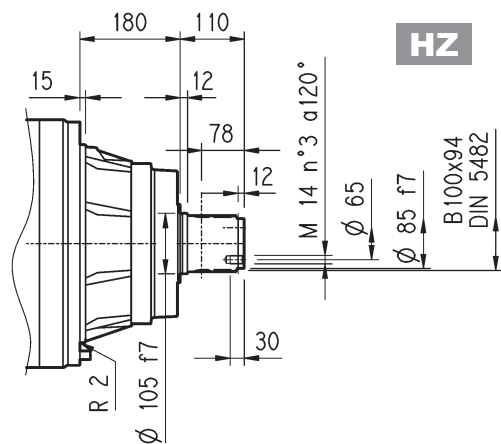

FZ

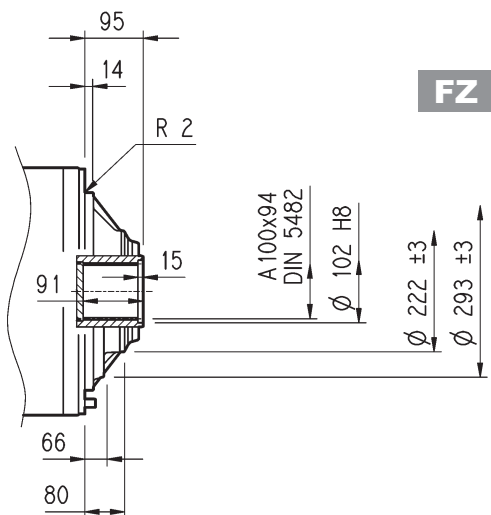

FP

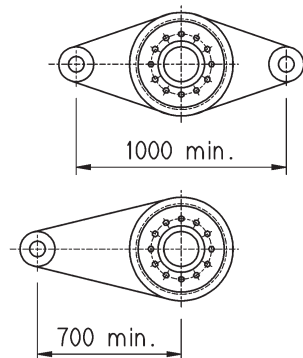
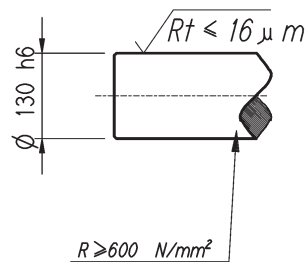
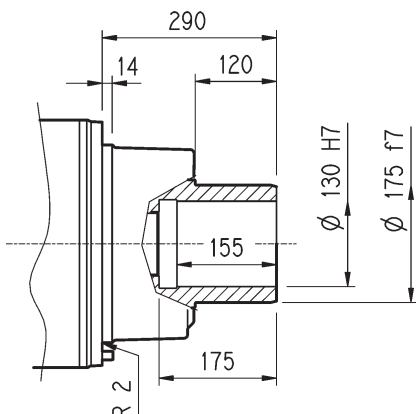

FP

$M_{2max} = 36\,000$ Nm

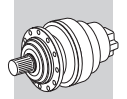
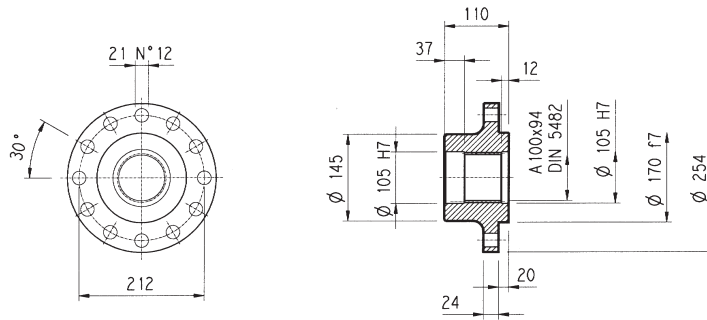
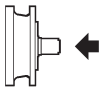
310 L**310 R****3/V 10L3****3/V 10L4**
Flangia / Flange
Flansch / Brides
W0A

Materiale : Acciaio C40
 Material : Steel C40
 Material : Stahl C40
 Matière : Acier C40

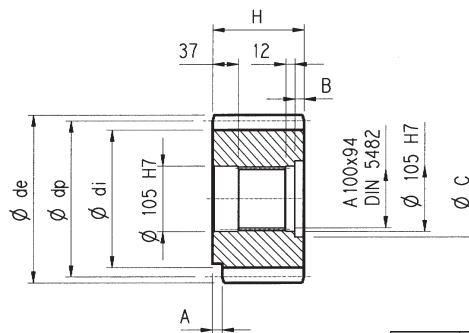
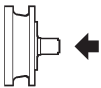
Pignone / Pinion gears
Ritzel / Pignons
P...

	m	z	x	dp	di	de	H	A	B	C	☆
PLQ	12	23	0	276	246	300	110	0	0	0	■
PPD	16	13	0.500	208	184	252.5	145	0	35	116	□
PPF	16	15	0.450	240	215	280	125	0	15	120	■

☆	Materiale / Material / Material / Matière
□	Acciaio 39NiCrMo3 Bonificato Steel 39NiCrMo3 hardened and tempered Vergüteter Stahl 39NiCrMo3 Acier bonifiée 39NiCrMo3
■	Acciaio 18NiCrMo5 Cementato e temprato Steel 18NiCrMo5 Case hardened Einsatzstahl 18NiCrMo5 Einsatzgehärtet Acier cémentée et tempré 18NiCrMo5

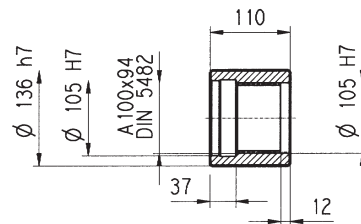
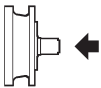
Manicotti lisci / Sleeve couplings
Naben / Manchons lisses a cannelure interieure
MOA

Materiale : Acciaio 16CrNi4
 Material : Steel 16CrNi4
 Material : Stahl 16CrNi4
 Matière : Acier 16CrNi4

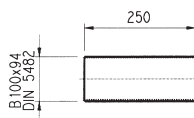
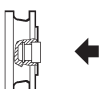
Barre scanalate / Splined bars
Vielkeilwellen / Barre cannelée
B0A

Mat. acciaio 18NiCrMo5 UNI 5331 da cementare e temprare 50-55 HRC
 Case hardening steel 18NiCrMo5 UNI 5331 must be case hardened 50-55 HRC
 Material: Einsatzstahl 18NiCrMo5 UNI 5331 muss einsatzgehärtet werden 50-55 HRC
 Acier 18 NiCrMo5 UNI 5331 doit être cémenté trempé 50-55 HRC

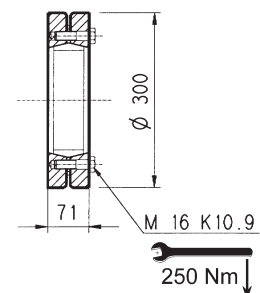
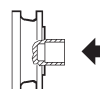
Giunto ad attrito / Shrink disc
Schrumpfscheibe / Frette de serrage
G0A

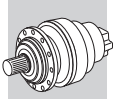

310 L

310 R

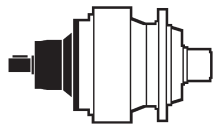
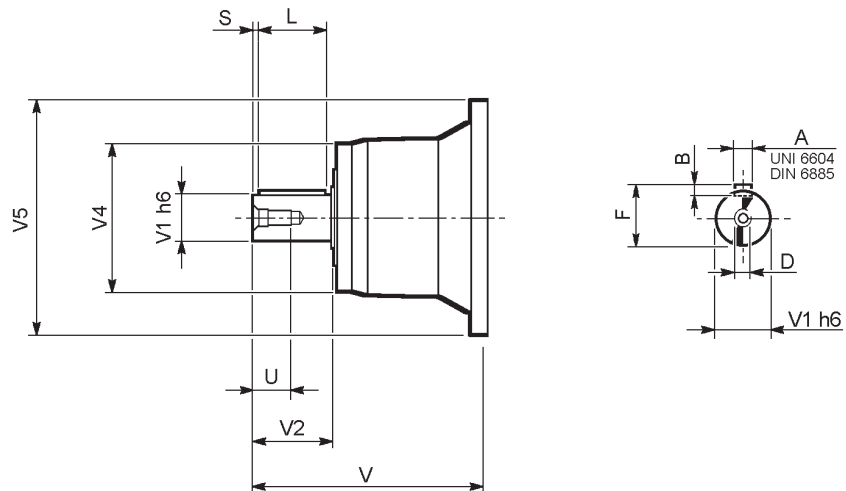

	CODE	V	V1	V2	V4	V5	A	B	F	L	S	D	U
310 L1	V10B	377	80	130	200	400	22	14	85	110	10	M16	36
310 L2	V06B	307	60	105	155	292	18	11	64	90	7.5	M16	36
310 L3	V05B	239	48	82	155	245	14	9	51.5	70	6	M16	36
310 L4	V01A	137.5	24	36	120	186	8	7	27	30	3	M8	19
	V01B	158	38	58	120	186	10	8	41	50	4	M12	28
310 R2 (B)	V06B	307	60	105	155	292	18	11	64	90	7.5	M16	36
310 R2 (A)	V05B	239	48	82	155	245	14	9	51.5	70	6	M16	36
310 R3-R4	V01A	137.5	24	36	120	186	8	7	27	30	3	M8	19
	V01B	158	38	58	120	186	10	8	41	50	4	M12	28

3/V 10L3

3/V 10L4

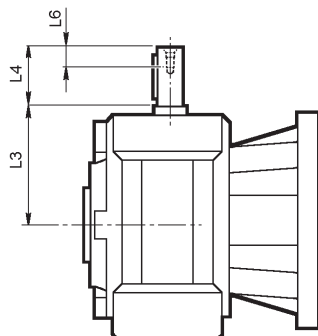
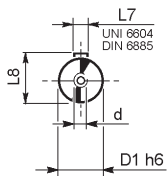

	D1 h6	L3	L4	L6	L7	L8	d
3/V 10L3_HS	35	185	65	20	10	38	M8
3/V 10L4_HS	25	144	50	19	8	28	M8

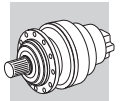

Fattore di posizione per carichi radiali sugli alberi in uscita.

Load location factor for radial loading on output shaft.

Positionsfaktor für Radialkräfte an der Abtriebswelle.

Facteur de position pour charges radiales sur les arbres en sortie.

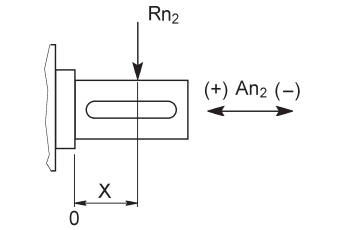
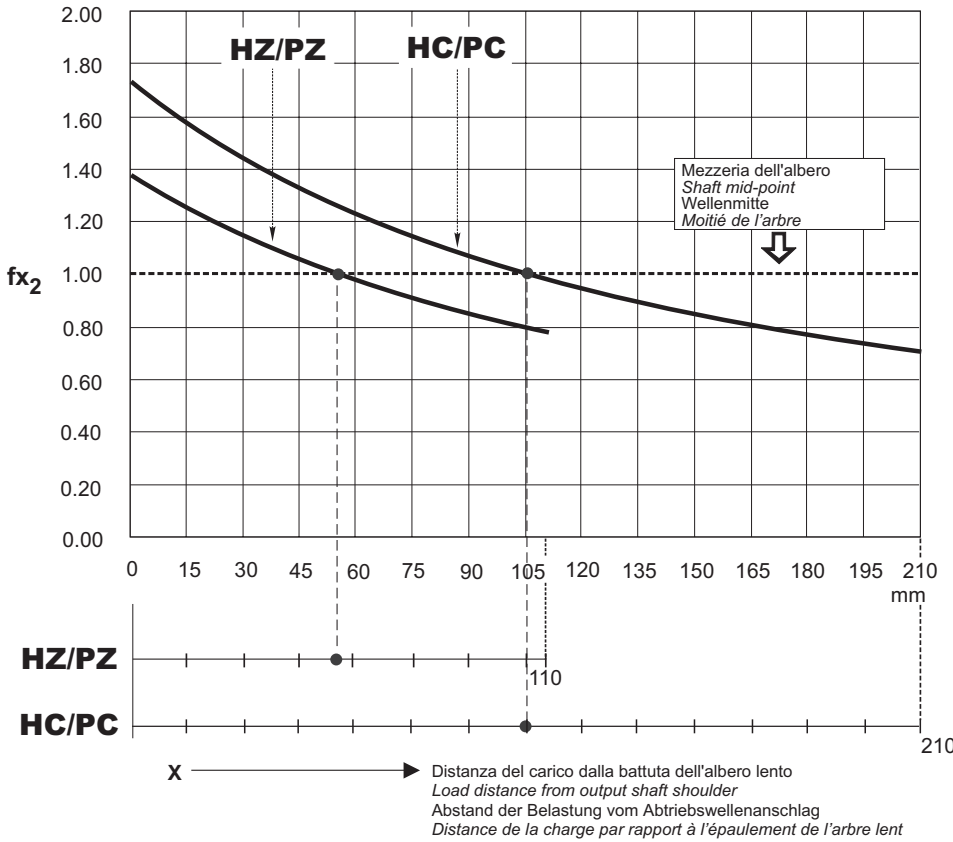

$$R_{x2} = R_{n2} \cdot f_{x2}$$

$An_2 (\pm) = R_{n2} \cdot fa_2 (\pm)$		
	$fa_2 (+)$	$fa_2 (-)$
HZ/PZ	1.02	0.60
HC/PC	1.28	0.75

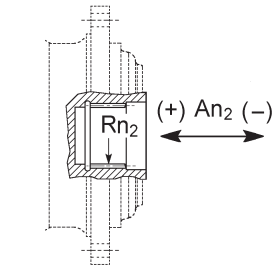

$An_2 (\pm) = R_{n2} \cdot fa_2 (\pm)$		
	$fa_2 (+)$	$fa_2 (-)$
FZ	0.80	0.80

Carichi radiali ammissibili sull'albero veloce per $n_1 = 1000 \text{ min}^{-1}$ e 10000 h di vita teorica.

Permitted overhung loads on input shaft when $n_1 = 1000 \text{ min}^{-1}$ and theoretical lifetime = 10000 h.

Zulässige Radialkräfte an den Antriebswellen für $n_1 = 1000 \text{ min}^{-1}$ und 10000 std.

Charges radiales admissibles sur les arbres d'entrée pour $n_1 = 1000 \text{ min}^{-1}$ et 10000 h.

Per velocità di comando e/o durate diverse vedi il capitolo: Verifiche.

For drive speed and/or lifetimes other than those specified here, see Chapter: Verifications.

Im Hinblick auf Geschwindigkeit und/oder anderweitige Dauern verweisen wir auf Par. Prüfungen

Pour des vitesses et/ou durées différentes, voir par. Vérifications.

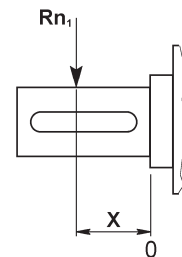
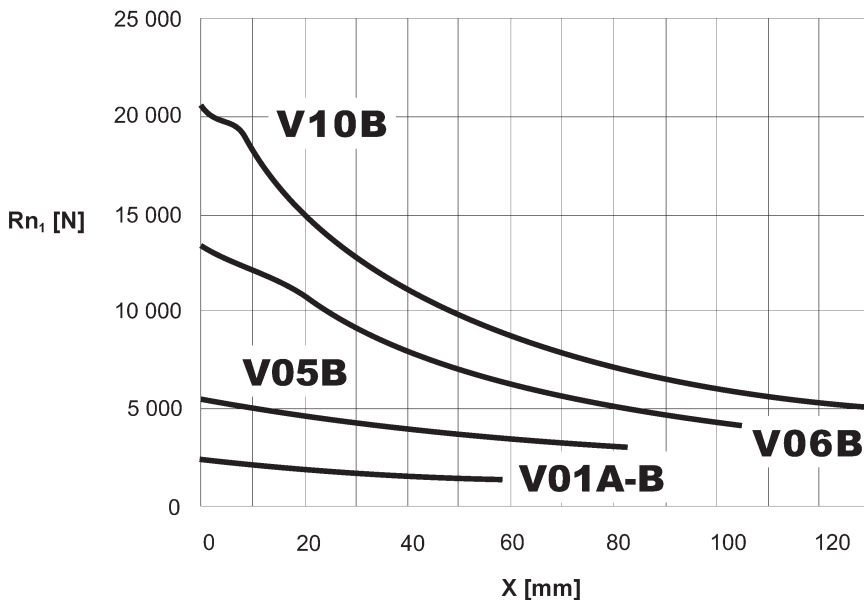

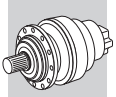

310_VK

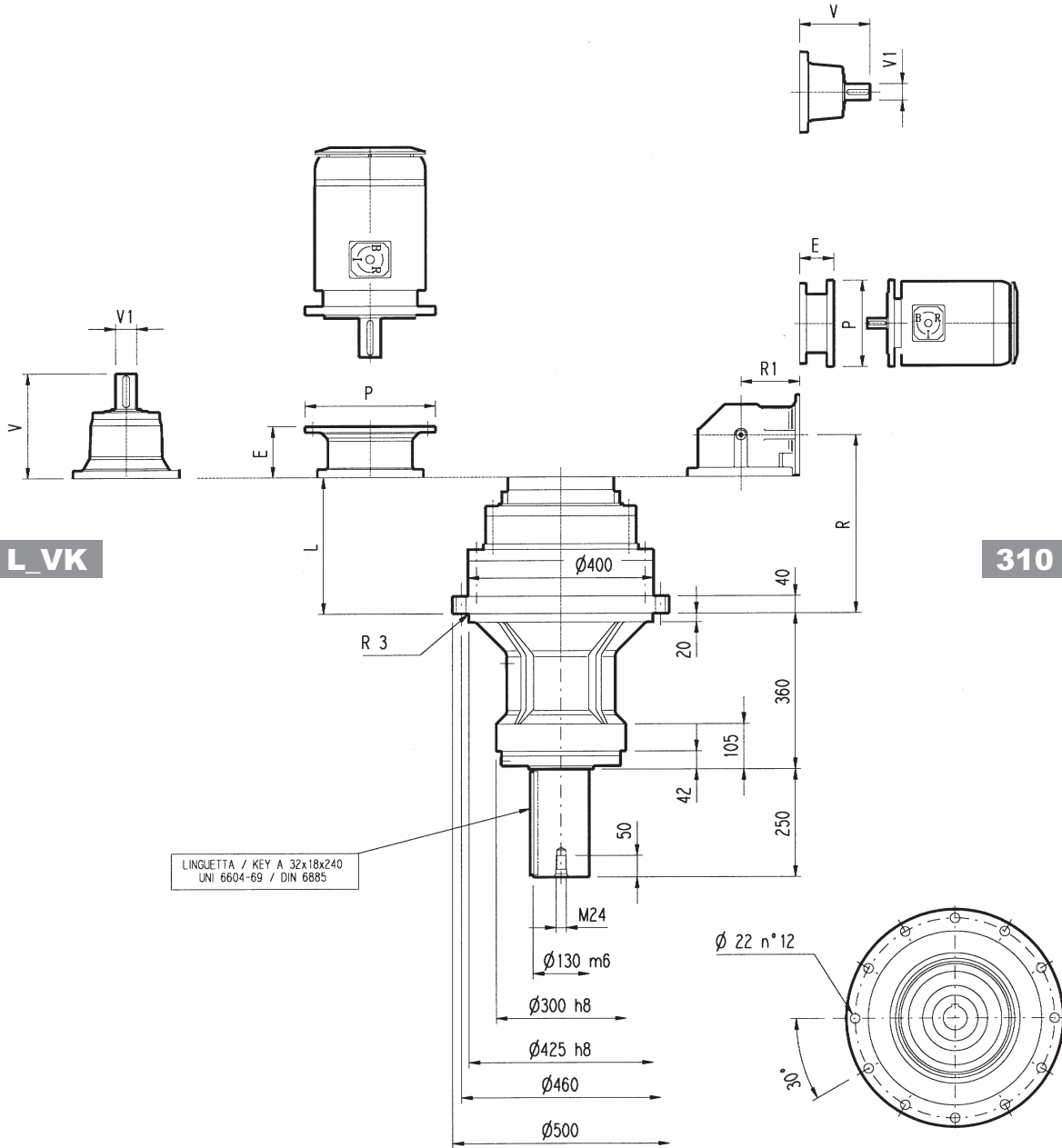

310 L_VK

310 R_VK

	L	Kg	Albero veloce / Input shaft / Antriebswelle / Arbre d'entrée					
			V	V1	Kg	V	V1	Kg
310 L1	107	200	377	80	50	-	-	-
310 L2	243	230	307	60	23	-	-	-
310 L3	308	240	239	48	15	-	-	-
310 L4	361	245	137.5	24	6	158	38	7

	P71		P80		P90		P100		P112		P132		P160		P180		P200L		P225		P250M	
	E	P	E	P	E	P	E	P	E	P	E	P	E	P	E	P	E	P	E	P	E	P
310 L1	-	-	-	-	-	-	-	-	-	-	-	-	-	-	-	-	280	400	310	450	290	550
310 L2	-	-	-	-	-	-	-	-	-	-	-	-	-	-	153	350	183	400	-	-	-	-
310 L3	-	-	-	-	-	-	-	-	-	-	114	300	144	350	144	350	-	-	-	-	-	-
310 L4	65	160	84	200	84	200	94	250	94	250	114	300	-	-	-	-	-	-	-	-	-	-

	R	R1	Kg	Albero veloce / Input shaft / Antriebswelle / Arbre d'entrée					
				V	V1	Kg	V	V1	Kg
310 R2 (B)	315	345	320	307	60	23	-	-	-
310 R2 (A)	315	330	300	239	48	15	-	-	-
310 R3	380	140	250	137.5	24	6	158	38	7
310 R4	400	140	260	137.5	24	6	158	38	7

	P71		P80		P90		P100		P112		P132		P160M		P180		P200L		P225	
	E	P	E	P	E	P	E	P	E	P	E	P	E	P	E	P	E	P	E	P
310 R2 (B)	-	-	-	-	-	-	-	-	-	-	-	-	-	-	152	350	182	400	212	450
310 R2 (A)	-	-	-	-	-	-	-	-	-	-	-	-	-	-	144	350	174	400	174	450
310 R3	65	160	84	200	84	200	94	250	94	250	114	300	144	350	-	-	-	-	-	-
310 R4	65	160	84	200	84	200	94	250	94	250	114	300	-	-	-	-	-	-	-	-

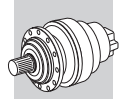

Il diagramma seguente consente di ricavare il carico radiale ammissibile R_{x2} quando questo è applicato alla distanza x dallo spallamento dell'albero lento del riduttore 310_VK.

Le curve si riferiscono al valore risultante dal rapporto fra il carico assiale A_{n2} e il carico radiale R_{n2} , entrambi riferiti a $n_2 = 10 \text{ min}^{-1}$ e durata teorica di 10000 h.

The diagram below allows the calculation of permitted overhung load R_{x2} on the output shaft of gearbox type 310_VK, with radial force applying at a distance x from shaft shoulder.

The curves are relevant to value resulting from the relationship of trust load A_{n2} to radial load R_{n2} , based on $n_2 = 10 \text{ min}^{-1}$ and 10000 hrs theoretical lifetime.

Das nachstehende Diagramm ermöglicht das Individuieren der zulässigen, auf die Welle des Getriebes 310_VK einwirkenden Radialkraft, die auf der Distanz x vom Anschlag der Welle selbst appliziert wird.

Die Kurven beziehen sich auf den Wert, der sich aus dem Verhältnis zwischen der Axialkraft A_{n2} und der Radialkraft R_{n2} für $n_2 = 10 \text{ min}^{-1}$ und einer Dauer von 10000 Std. ergibt.

Le diagramme suivant permet de déterminer la charge radiale admissible R_{x2} sur l'arbre lent du réducteur 310_VK appliqué à la distance x de l'épaule de l'arbre.

Les courbes se réfèrent à la valeur résultant de l'équation entre la charge axiale A_{n2} et la charge radiale R_{n2} pour $n_2 = 10 \text{ min}^{-1}$ et durée de 10000 h.

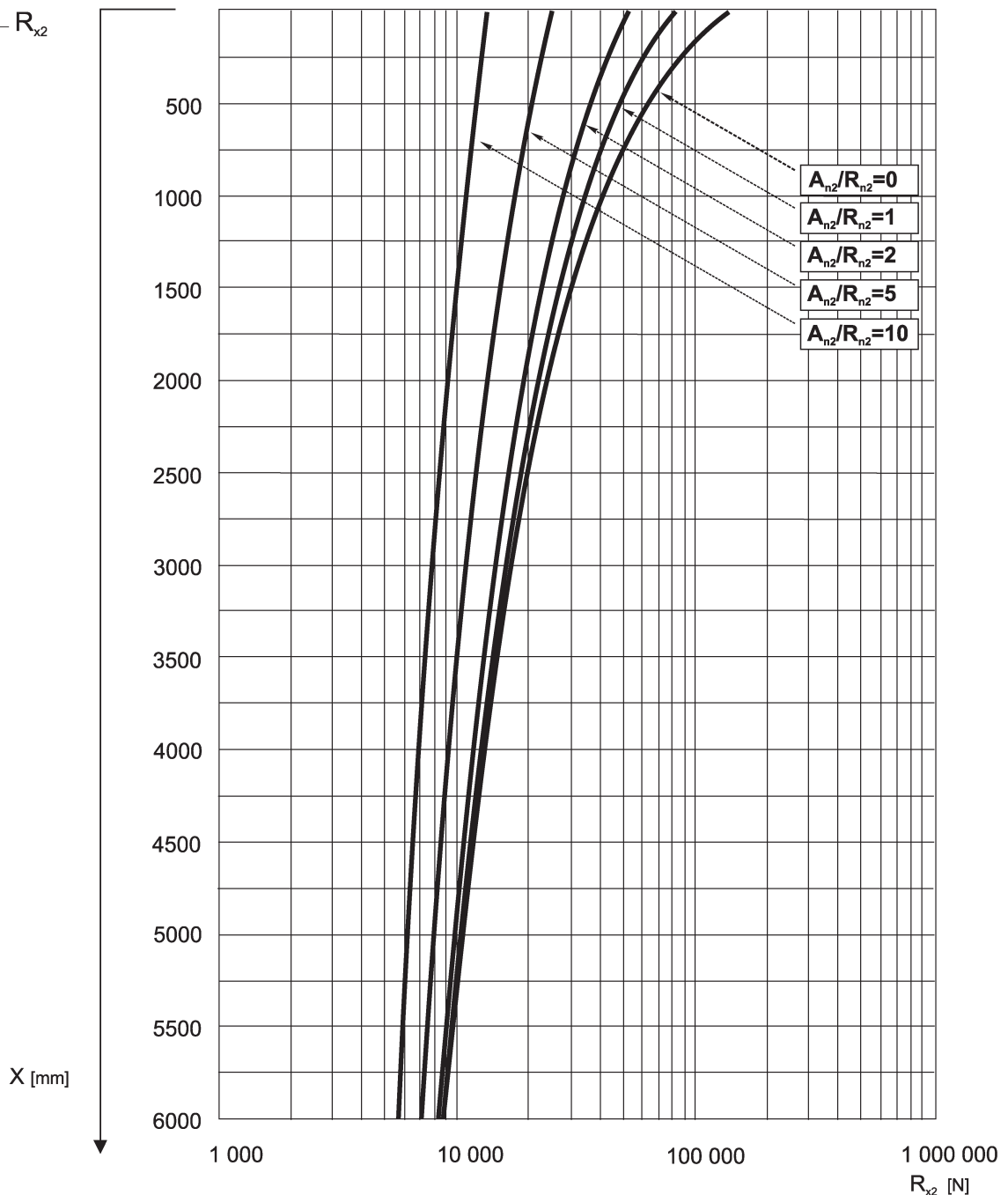
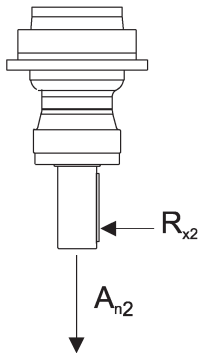

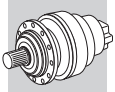

311 L

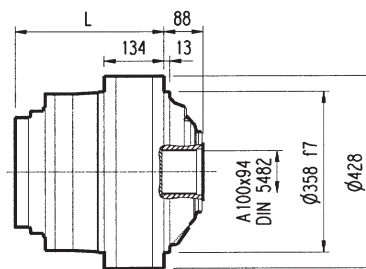
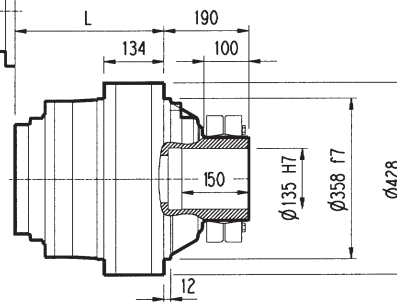
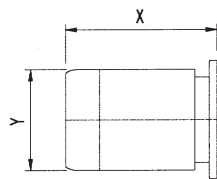
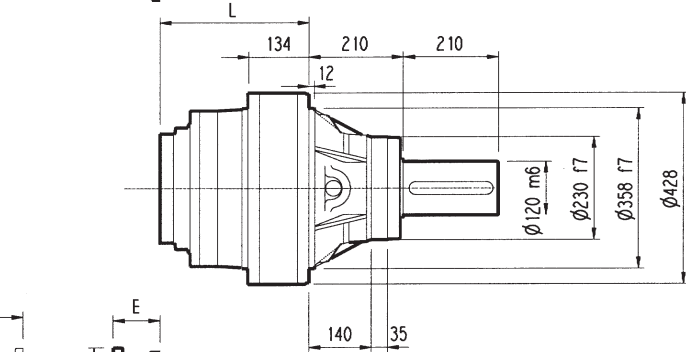
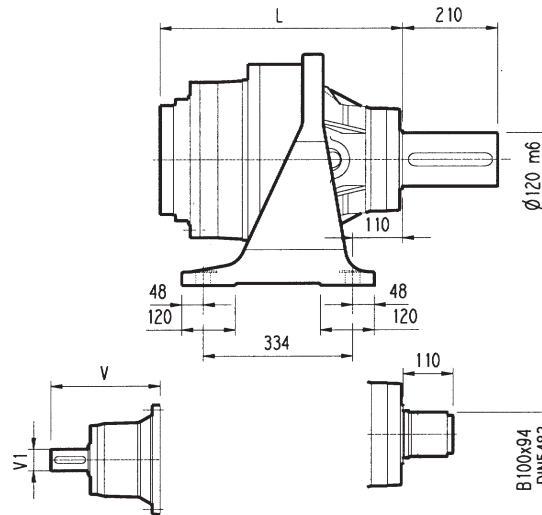
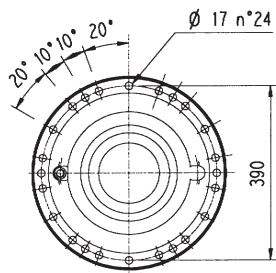
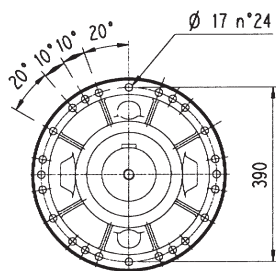
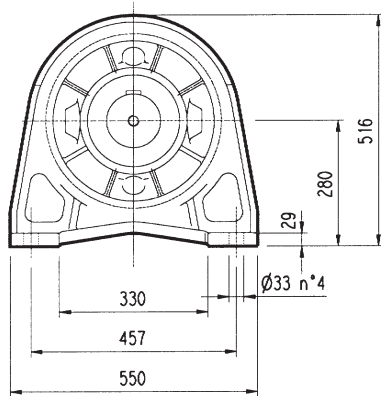

PC

HZ PZ

HC

FP

FZ

FP

$M_{2max} = 54\,000 \text{ Nm}$

	L				Kg				Albero veloce / Input shaft / Antriebswelle / Arbre d'entrée					
	PC - PZ	HC - HZ	FZ	FP	PC - PZ	HC - HZ	FZ	FP	V	V1	Kg	V	V1	Kg
311 L1	325	115	115	115	250	180	160	170	348	80	55	-	-	-
311 L2	458	248	248	248	295	225	205	215	315	80	35	313	60	28
311 L3	547	337	337	337	307	237	217	227	239	48	15	-	-	-
311 L4	612	402	402	402	314	244	224	234	137.5	24	6	158	38	7

	P71		P80		P90		P100		P112		P132		P160		P180		P200		P225		P250M	
	E	P	E	P	E	P	E	P	E	P	E	P	E	P	E	P	E	P	E	P	E	P
311 L1	-	-	-	-	-	-	-	-	-	-	-	-	-	-	-	-	-	-	-	-	-	-
311 L2	-	-	-	-	-	-	-	-	-	-	-	-	195	350	186	400	216	450	216	450	216	550
311 L3	-	-	-	-	-	-	-	-	-	-	114	300	144	350	144	350	-	-	-	-	-	-
311 L4	65	160	84	200	84	200	94	250	94	250	114	300	144	350	-	-	-	-	-	-	-	-

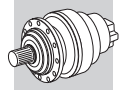

PC

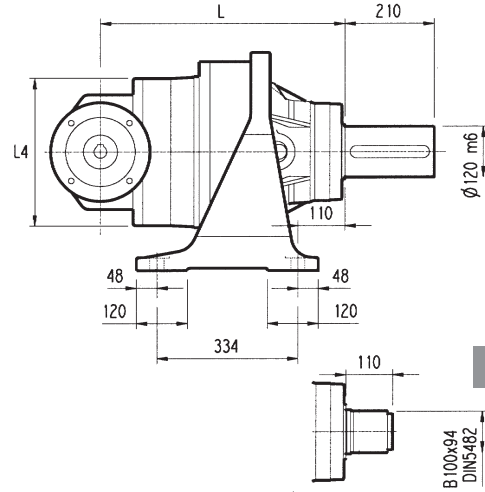
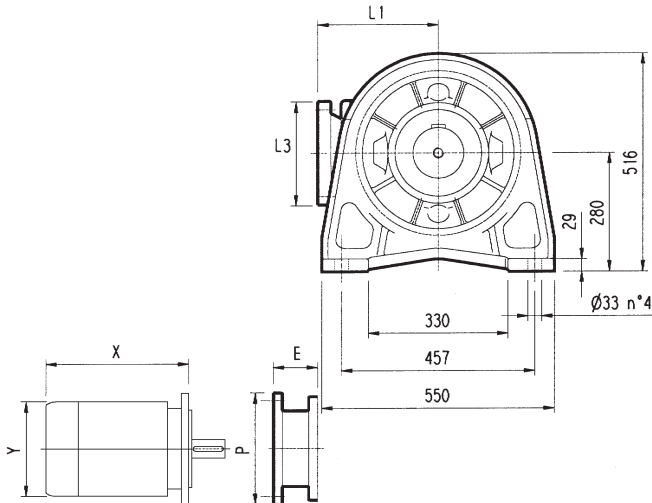

HZ PZ

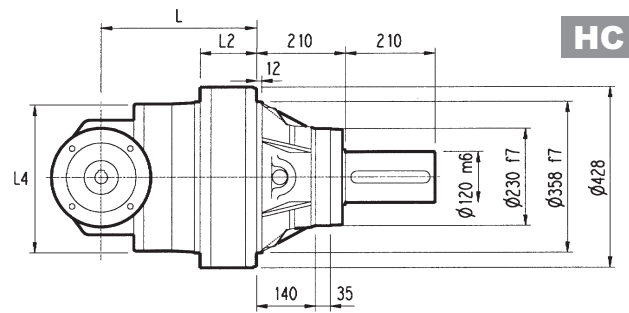
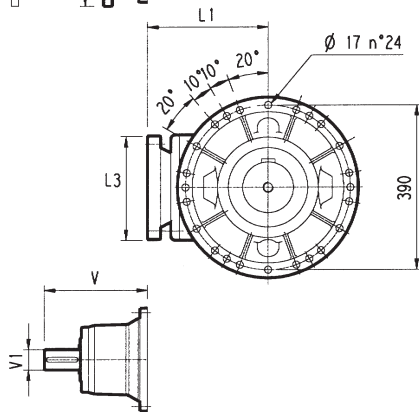

HC

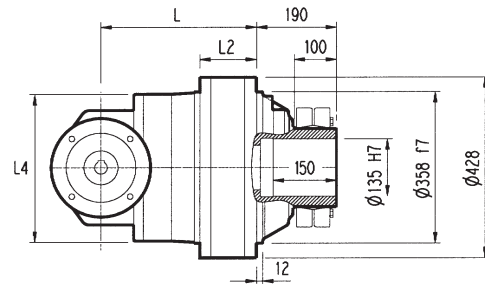
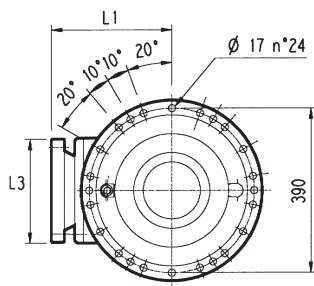

FP

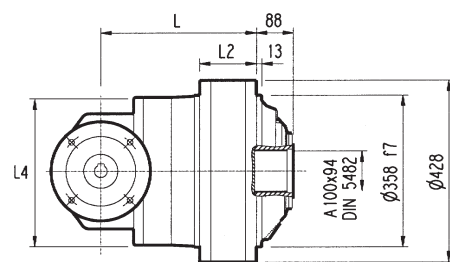

FZ

FP $M_{2max} = 54\,000 \text{ Nm}$

	L				L1	L2			L3	L4	Albero veloce / Input shaft Antriebswelle / Arbre d'entrée										
	PC - PZ	HC - HZ	FZ	FP		HZ - HC	FZ	FP			Kg				V	V1	Kg	V	V1	Kg	
											PC - PZ	HC - HZ	FZ	FP							V
311 R2 (B)	550	340	340	340	345	154	154	154	292	400	380	310	290	300	307	60	23	-	-	-	-
311 R2 (C)	550	340	340	340	390	154	154	154	292	480	390	320	300	310	307	60	23	-	-	-	-
311 R2 (A)	550	367	340	340	330	154	154	154	245	390	360	290	270	280	239	48	15	-	-	-	-
311 R3	577	429	367	367	225	134	134	134	245	375	345	275	255	265	239	48	15	-	-	-	-
311 R4	639		429	429	140	134	134	134	186	244	327	257	237	247	137.5	24	6	158	38	7	

	P71		P80		P90		P100		P112		P132		P160M		P180		P200L		P225		P250	
	E	P	E	P	E	P	E	P	E	P	E	P	E	P	E	P	E	P	E	P	E	P
311 R2 (B)	-	-	-	-	-	-	-	-	-	-	-	-	-	-	152	350	182	400	212	450	193	550
311 R2 (C)	-	-	-	-	-	-	-	-	-	-	-	-	-	-	152	350	182	400	212	450	193	550
311 R2 (A)	-	-	-	-	-	-	-	-	-	-	114	300	144	350	144	350	174	400	-	-	-	-
311 R3	-	-	-	-	-	-	-	-	-	-	114	300	144	350	144	350	-	-	-	-	-	-
311 R4	65	160	84	200	84	200	94	250	94	250	114	300	144	350	-	-	-	-	-	-	-	-

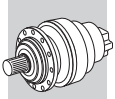

3/V 11L3

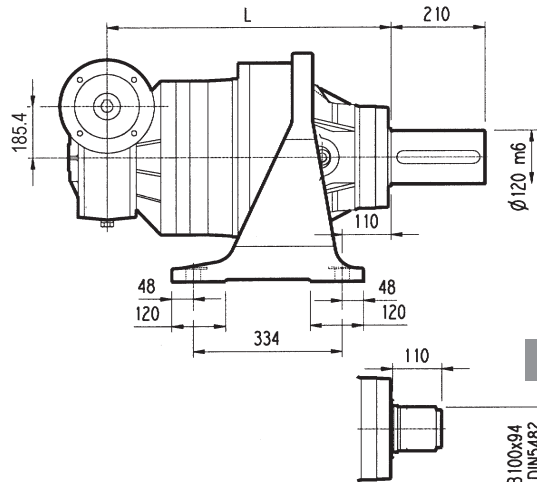
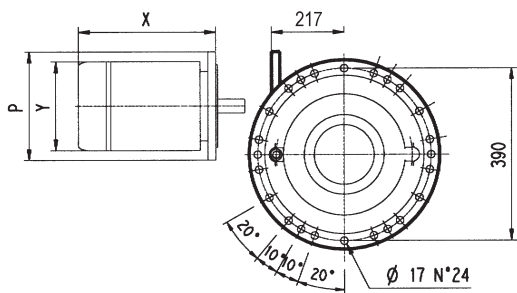
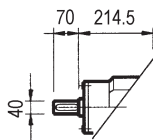
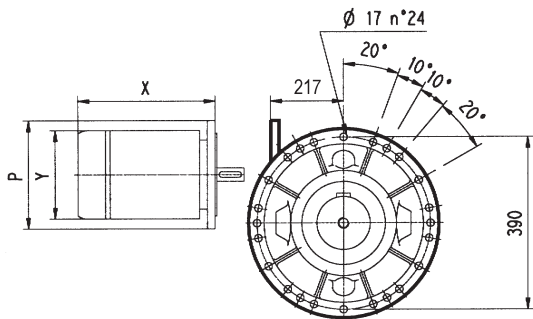
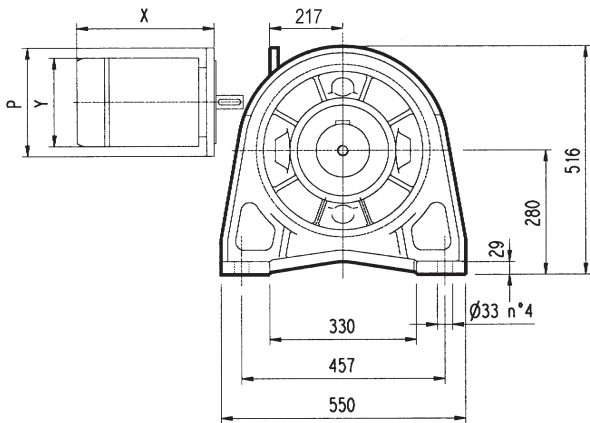

PC

HZ PZ

B100x94
DIN5482

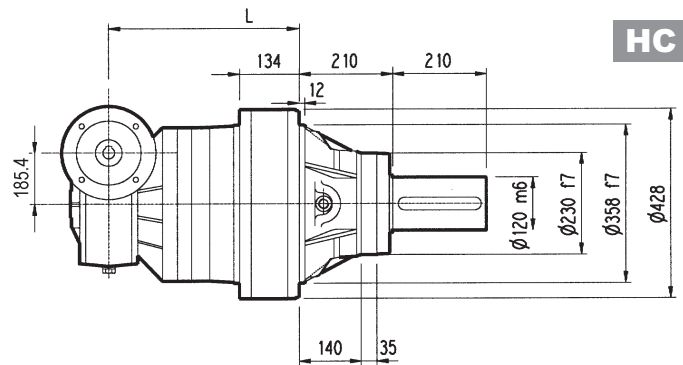

HC

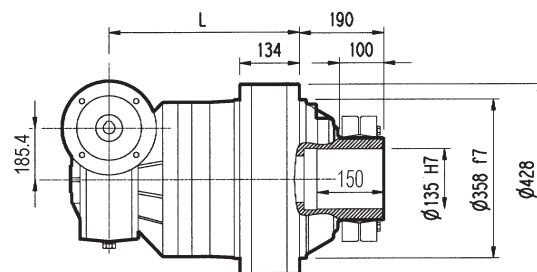

FP

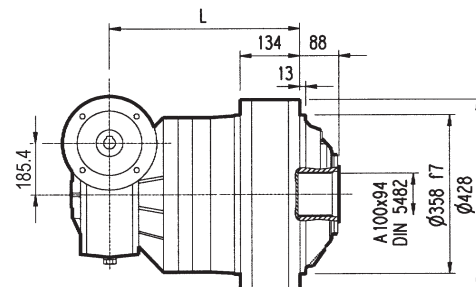

FZ

FP $M_{2max} = 54\,000 \text{ Nm}$

	L				$\overset{\circ}{\text{Kg}}$				P80	P90	P100	P112	P132	P160	P180
	PC - PZ	HC - HZ	FZ	FP	PC - PZ	HC - HZ	FZ	FP	P	P	P	P	P	P	P
3/V 11L3	659	449	449	449	390	320	300	310	-	-	250	250	300	350	350

3/V 11L4

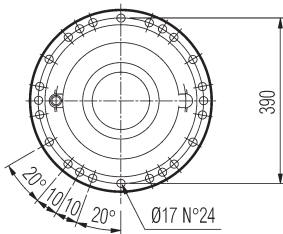
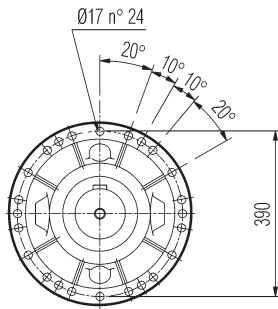
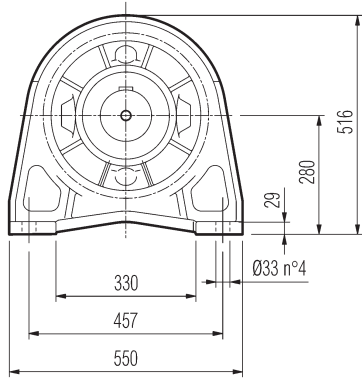
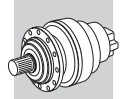

VISTA DA A
VIEW FROM A

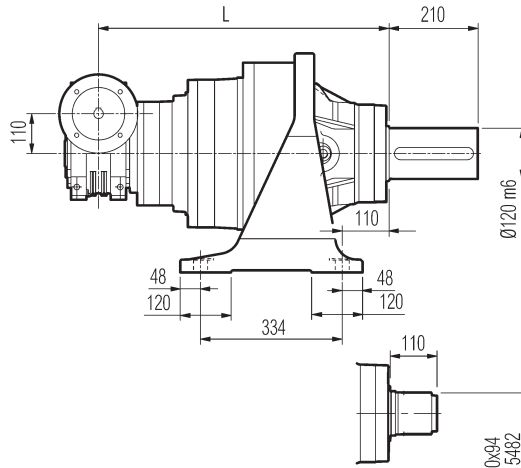
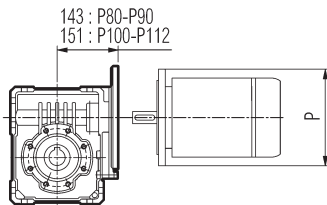
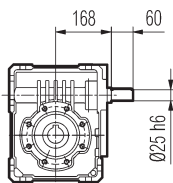

PC

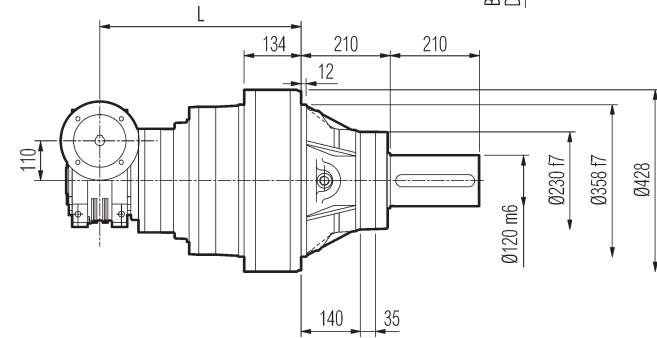

HZ PZ

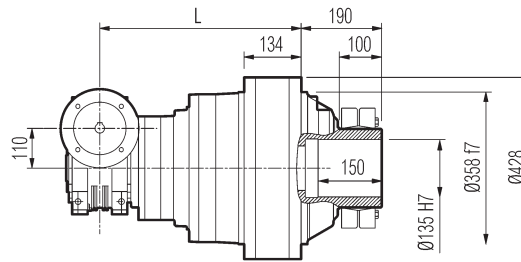

HC

FP

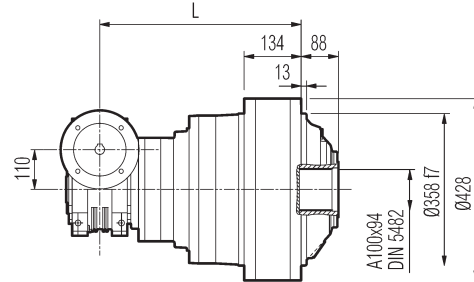

FZ

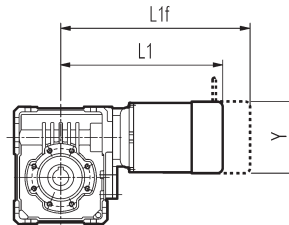

FP

$M_{2max} = 54\ 000\ Nm$

3/V 11L4	L				Kg								
	PC - PZ	HC - HZ	FZ	FP	PC - PZ	HC - HZ	FZ	FP					
	707	497	497	497	340	270	250	260					
3/V 11L4	P80	P90	P100	P112	S2 - M2S			S3 - M3S			S3 - M3L		
	P	P	P	P	L1	L1f	Y	L1	L1f	Y	L1	L1f	Y
	200	200	250	250	364	440	156	407	503	193	439	530	193

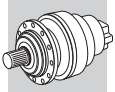

311 L

311 R

3/V 11L3

3/V 11L4

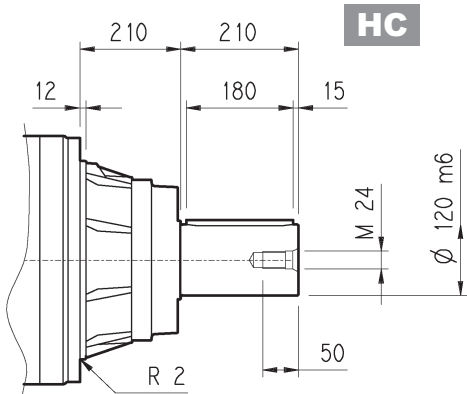

HC

A 32x18x180
UNI 6604
DIN 6885

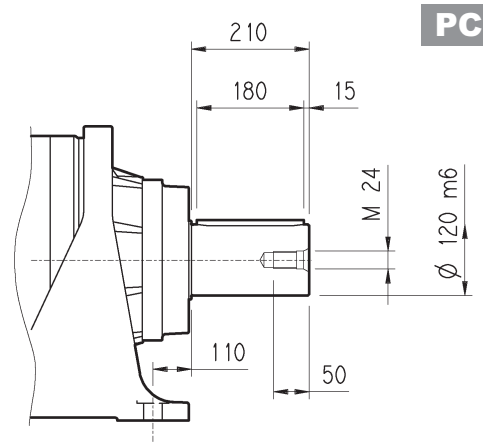
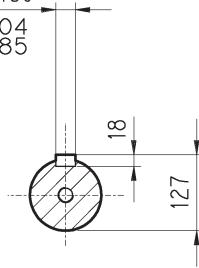

PC

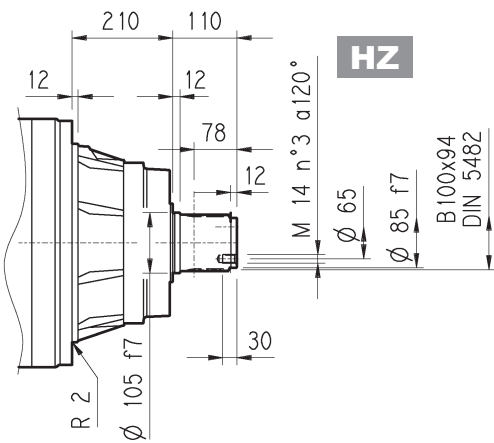

HZ

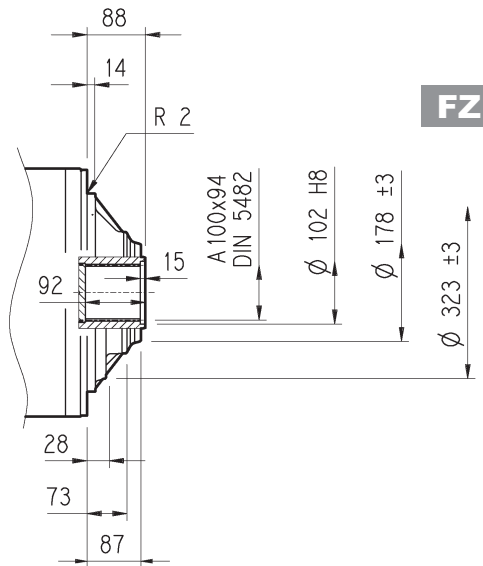
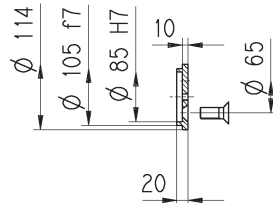

FZ

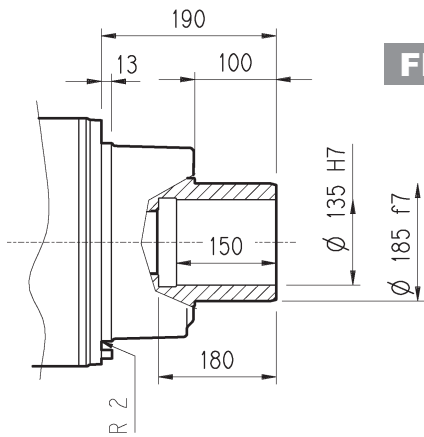

FP

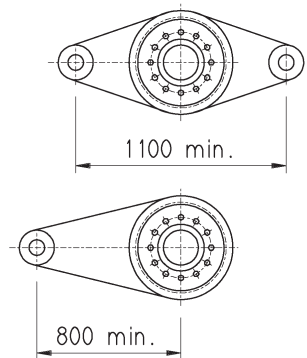
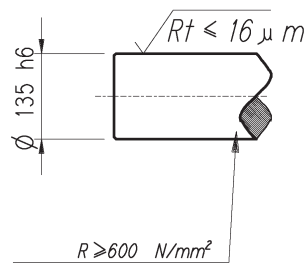

FP

$M_{2max} = 54\ 000\ Nm$

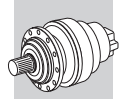
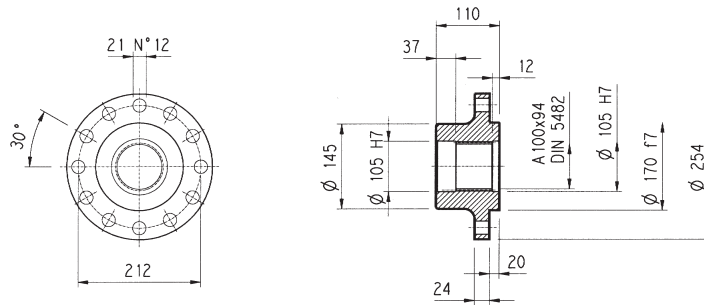
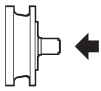
311 L**311 R****3/V 11L3****3/V 11L4**
Flangia / Flange
Flansch / Brides
W0A
 Materiale : Acciaio C40
 Material : Steel C40
 Material : Stahl C40
 Matière : Acier C40

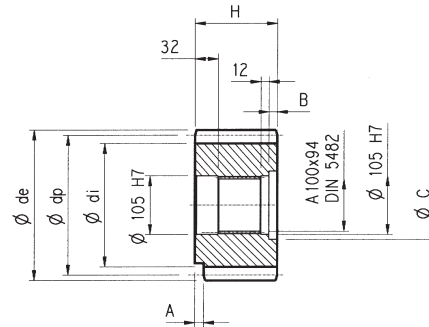
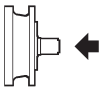
Pignoni / Pinion gears
Ritzel / Pignons
P...

	m	z	x	dp	di	de	H	A	B	C	☆
PLQ	12	23	0	276	246	300	110	0	0	0	■
PPD	16	13	0.500	208	184	252.5	145	0	35	116	□
PPF	16	15	0.450	240	215	280	125	0	15	120	■

☆	Materiale / Material / Material / Matière
□	Acciaio 39NiCrMo3 Bonificato Steel 39NiCrMo3 hardened and tempered Vergüteter Stahl 39NiCrMo3 Acier bonifiée 39NiCrMo3
■	Acciaio 18NiCrMo5 Cementato e temprato Steel 18NiCrMo5 Case hardened Einsatzstahl 18NiCrMo5 Einsatzgehärtet Acier cémenté et tempré 18NiCrMo5

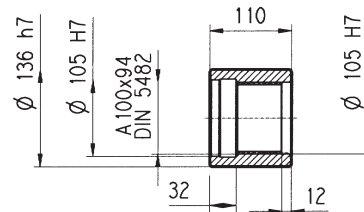
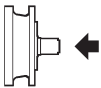
Manicotti lisci / Sleeve couplings
Naben / Manchons lisses a cannelure interieure
MOA
 Materiale : Acciaio 16CrNi4
 Material : Steel 16CrNi4
 Material : Stahl 16CrNi4
 Matière : Acier 16CrNi4

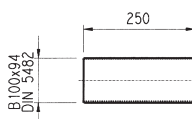
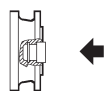
Barre scanalate / Splined bars
Vielkeilwellen / Barre cannelée
B0A
 Mat. acciaio 18NiCrMo5 UNI 5331 da cementare e
 temprare 50-55 HRC
 Case hardening steel 18NiCrMo5 UNI 5331 must be case
 hardened 50-55 HRC
 Material: Einsatzstahl 18NiCrMo5 UNI 5331 muss einsatzgehärtet
 werden 50-55 HRC
 Acier 18 NiCrMo5 UNI 5331 doit être cémenté trempé 50-55 HRC

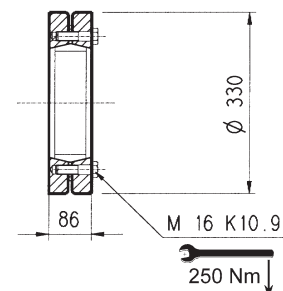
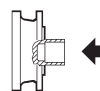
Giunto ad attrito / Shrink disc
Schrumpfscheibe / Frette de serrage
GOA

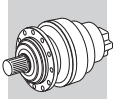

311 L

311 R

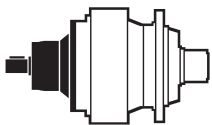
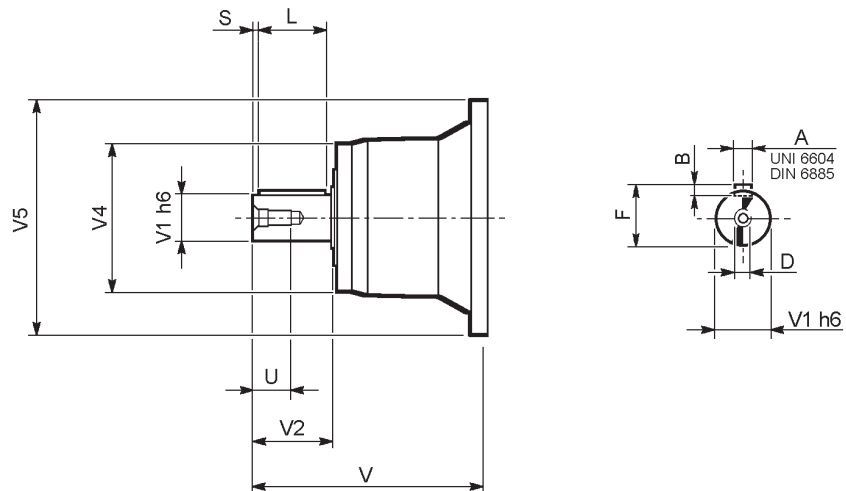

	CODE	V	V1	V2	V4	V5	A	B	F	L	S	D	U
311 L1	V11B	348	80	130	200	428	22	14	85	110	10	M16	36
311 L2	V07B	315	80	130	200	345	22	14	85	110	10	M16	36
	V07A	313	60	105	155	345	18	11	64	90	7.5	M16	36
311 L3	V05B	239	48	82	155	245	14	9	51.5	70	6	M16	36
311 L4	V01A	137.5	24	36	120	186	8	7	27	30	3	M8	19
	V01B	158	38	58	120	186	10	8	41	50	4	M12	28
311 R2 (A)	V05B	239	48	82	155	245	14	9	51.5	70	6	M16	36
311 R2 (B)(C)	V06B	307	60	105	155	292	18	11	64	90	7.5	M16	36
311 R3	V05B	239	48	82	155	245	14	9	51.5	70	6	M16	36
311 R4	V01A	137.5	24	36	120	186	8	7	27	30	3	M8	19
	V01B	158	38	58	120	186	10	8	41	50	4	M12	28

3/V 11L3

3/V 11L4

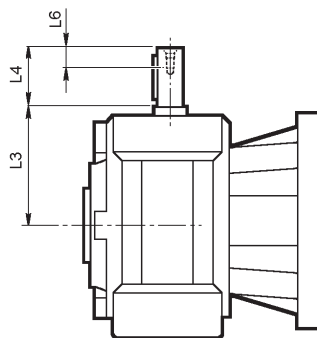
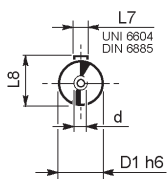

	D1 h6	L3	L4	L6	L7	L8	d
3/V 11L3 HS	40	214.5	70	20	12	43	M8
3/V 11L4 HS	25	168	60	19	8	28	M8

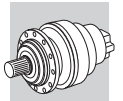

Fattore di posizione per carichi radiali sugli alberi in uscita.

Load location factor for radial loading on output shaft.

Positionsfaktor für Radialkräfte an der Abtriebswelle.

Facteur de position pour charges radiales sur les arbres en sortie.

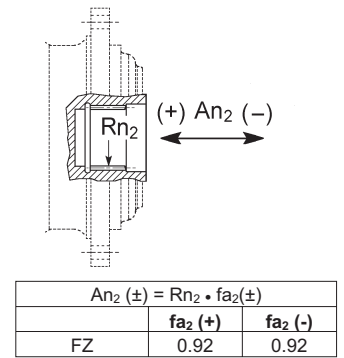
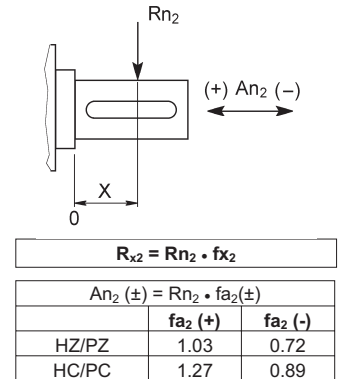
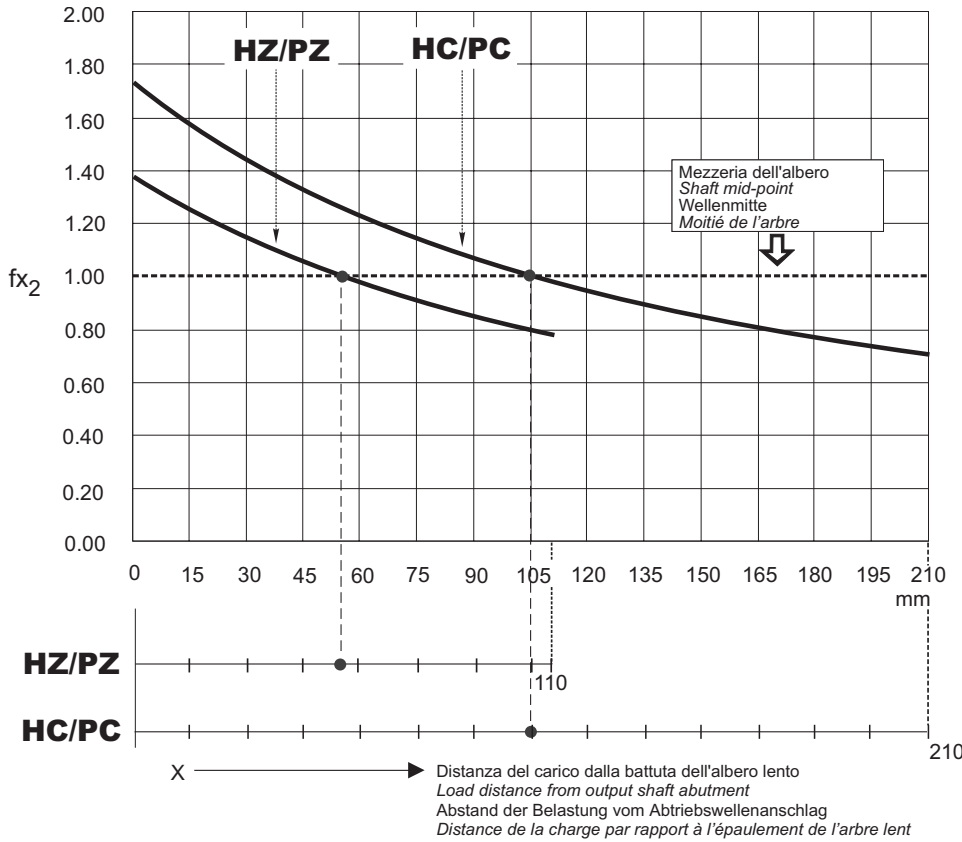

Carichi radiali ammissibili sull'albero veloce per $n_1 = 1000 \text{ min}^{-1}$ e 10000 h di vita teorica. Per velocità di comando e/o durate diverse vedi il capitolo: Verifiche.

Permitted overhung loads on input shaft when $n_1 = 1000 \text{ min}^{-1}$ and theoretical lifetime = 10000 h. For drive speed and/or lifetimes other than those specified here, see Chapter: Verifications.

Zulässige Radialkräfte an den Antriebswellen für $n_1 = 1000 \text{ min}^{-1}$ und 10000 std. Im Hinblick auf Geschwindigkeit und/oder anderweitige Dauern verweisen wir auf Par: Prüfungen

Charges radiales admissibles sur les arbres d'entrée pour $n_1 = 1000 \text{ min}^{-1}$ et 10000 h. Pour des vitesses et/ou durées différentes, voir par. Vérifications.

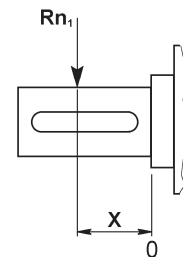
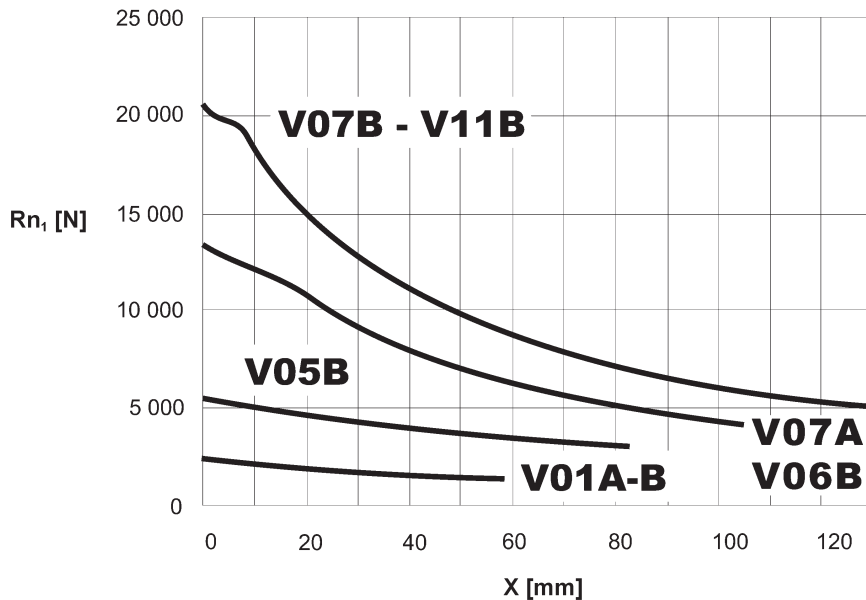

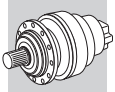

311_VK

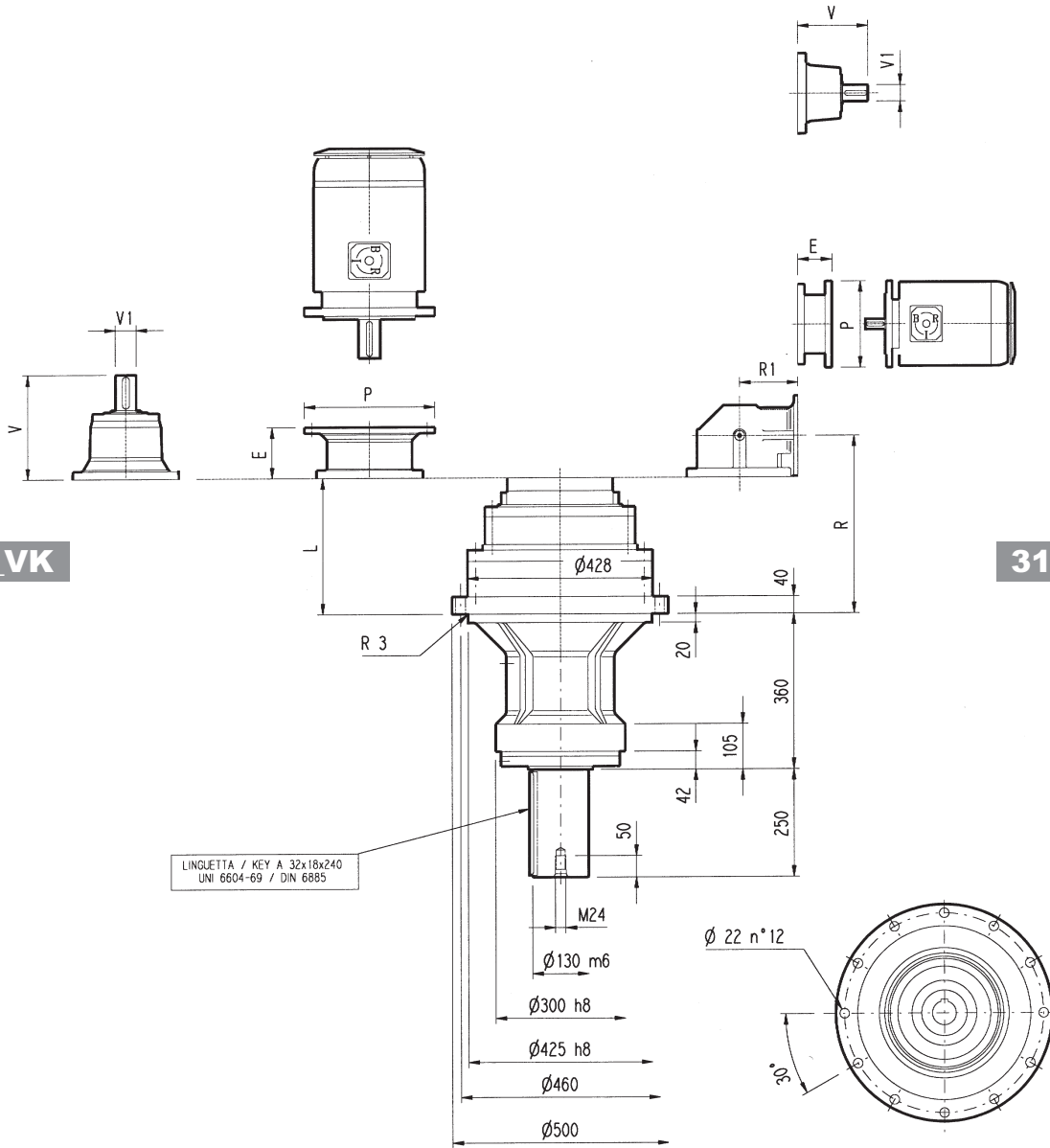

LINGUETTA / KEY A 32x18x240
UNI 6604-69 / DIN 6885

	L	Kg	Albero veloce / Input shaft / Antriebswelle / Arbre d'entrée					
			V	V1	Kg	V	V1	Kg
311 L1	129	295	348	80	55	-	-	-
311 L2	262	340	315	80	35	313	60	28
311 L3	351	350	239	48	15	-	-	-
311 L4	416	360	137.5	24	6	158	38	7

	P71		P80		P90		P100		P112		P132		P160		P180		P200L		P225		P250M	
	E	P	E	P	E	P	E	P	E	P	E	P	E	P	E	P	E	P	E	P	E	P
311 L1	-	-	-	-	-	-	-	-	-	-	-	-	-	-	-	-	-	-	-	-	-	-
311 L2	-	-	-	-	-	-	-	-	-	-	-	-	-	-	195	350	186	400	216	450	216	550
311 L3	-	-	-	-	-	-	-	-	-	-	114	300	144	350	144	350	-	-	-	-	-	-
311 L4	65	160	84	200	84	200	94	250	94	250	114	300	-	-	-	-	-	-	-	-	-	-

	R	R1	Kg	Albero veloce / Input shaft / Antriebswelle / Arbre d'entrée					
				V	V1	Kg	V	V1	Kg
311 R2 (B)	354	345	420	307	60	23	-	-	-
311 R2 (C)	354	390	430	307	60	23	-	-	-
311 R2 (A)	354	330	400	239	48	15	-	-	-
311 R3	381	225	385	239	48	15	-	-	-
311 R4	443	140	360	137.5	24	6	-	-	-

	P71		P80		P90		P100		P112		P132		P160M		P180		P200L		P225		P250	
	E	P	E	P	E	P	E	P	E	P	E	P	E	P	E	P	E	P	E	P	E	P
311 R2 (B)	-	-	-	-	-	-	-	-	-	-	-	-	-	-	152	350	182	400	212	450	193	550
311 R2 (C)	-	-	-	-	-	-	-	-	-	-	-	-	-	-	152	350	182	400	212	450	193	550
311 R2 (A)	-	-	-	-	-	-	-	-	-	-	114	300	144	350	144	350	174	400	-	-	-	-
311 R3	-	-	-	-	-	-	-	-	-	-	114	300	144	350	144	350	-	-	-	-	-	-
311 R4	65	160	84	200	84	200	94	250	94	250	114	300	144	350	-	-	-	-	-	-	-	-

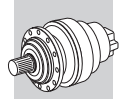

Il diagramma seguente consente di ricavare il carico radiale ammissibile R_{x2} quando questo è applicato alla distanza x dallo spallamento dell'albero lento del riduttore 311_VK.

Le curve si riferiscono al valore risultante dal rapporto fra il carico assiale A_{n2} e il carico radiale R_{n2} , entrambi riferiti a $n_2 = 10 \text{ min}^{-1}$ e durata teorica di 10000 h.

The diagram below allows the calculation of permitted overhung load R_{x2} on the output shaft of gearbox type 311_VK, with radial force applying at a distance x from shaft shoulder.

The curves are relevant to value resulting from the relationship of trust load A_{n2} to radial load R_{n2} , based on $n_2 = 10 \text{ min}^{-1}$ and 10000 hrs theoretical lifetime.

Das nachstehende Diagramm ermöglicht das Individuieren der zulässigen, auf die Welle des Getriebes 311_VK einwirkenden Radialkraft, die auf der Distanz x vom Anschlag der Welle selbst appliziert wird.

Die Kurven beziehen sich auf den Wert, der sich aus dem Verhältnis zwischen der Axialkraft A_{n2} und der Radialkraft R_{n2} für $n_2 = 10 \text{ min}^{-1}$ und einer Dauer von 10000 Std. ergibt.

Le diagramme suivant permet de déterminer la charge radiale admissible R_{x2} sur l'arbre lent du réducteur 311_VK appliqué à la distance x de l'épaule de l'arbre.

Les courbes se réfèrent à la valeur résultant de l'équation entre la charge axiale A_{n2} et la charge radiale R_{n2} pour $n_2 = 10 \text{ min}^{-1}$ et durée de 10000 h.

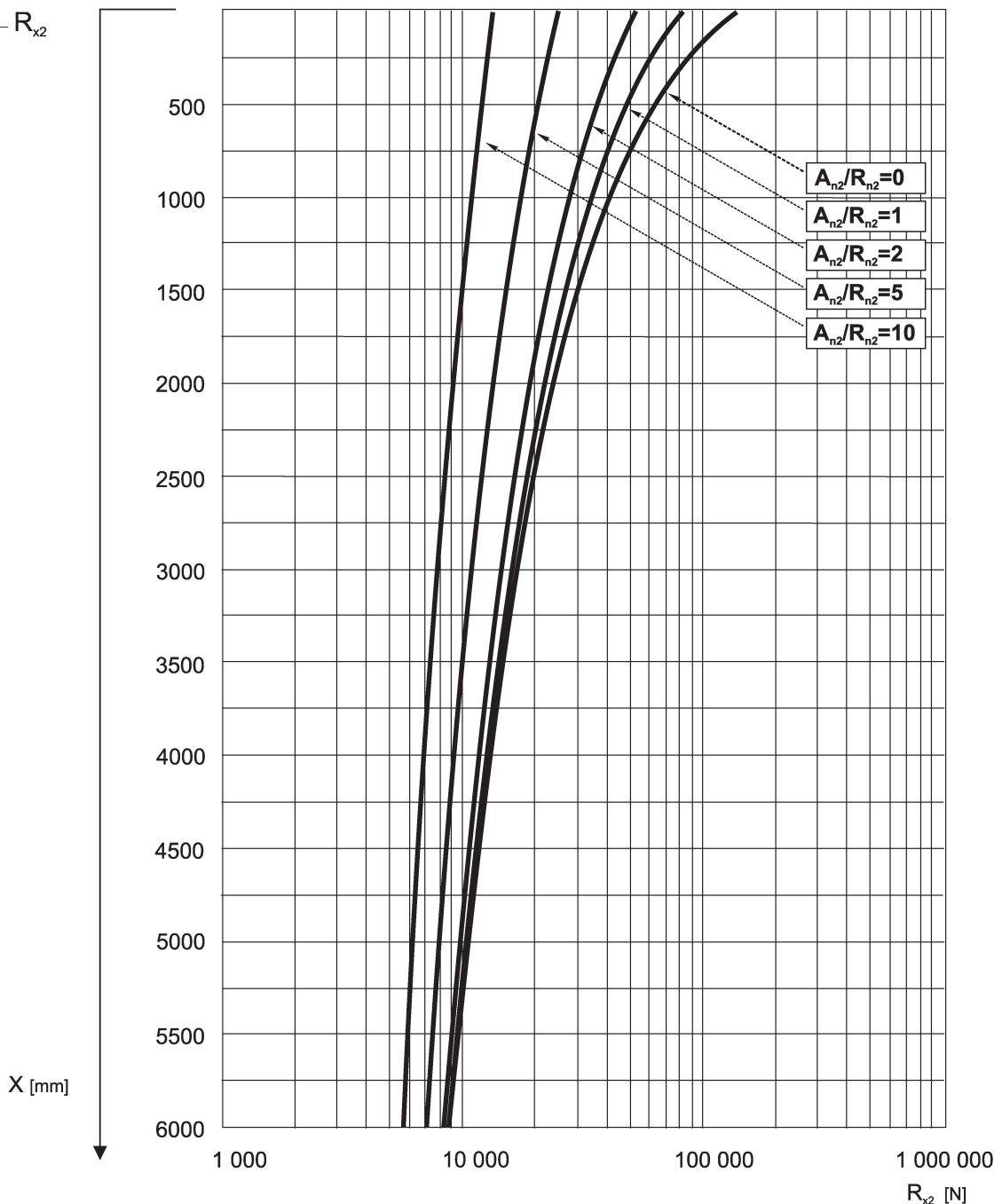
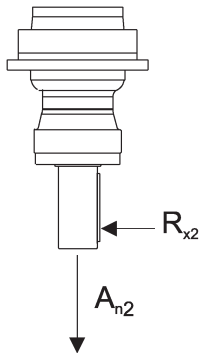

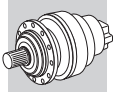

313 L

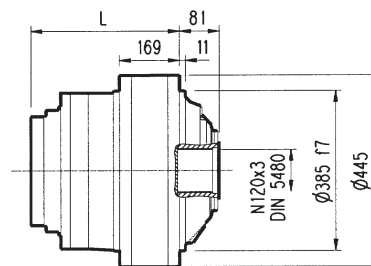
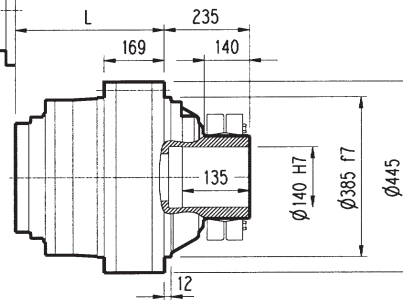
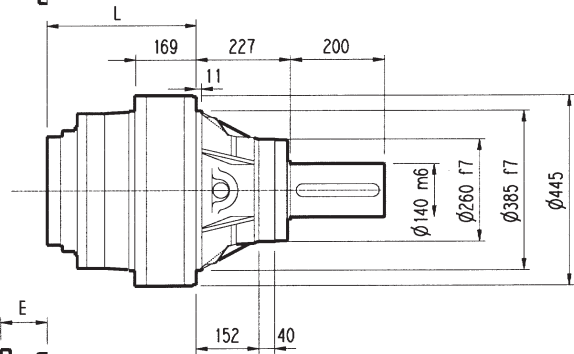
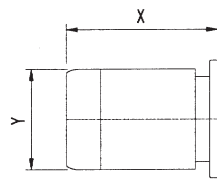
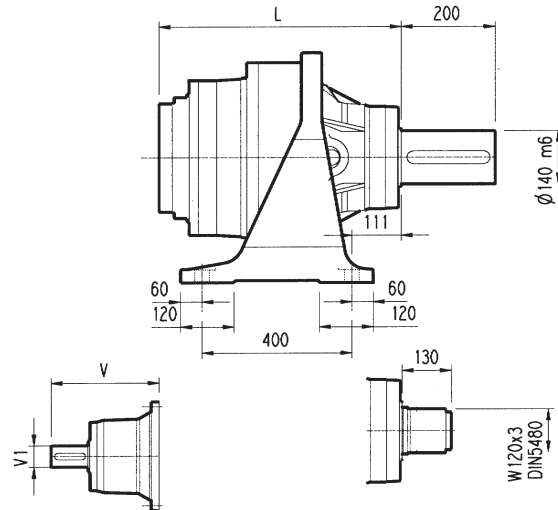
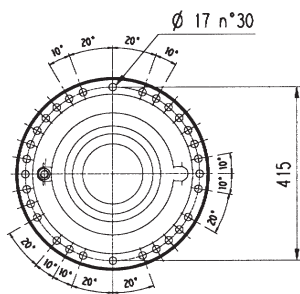
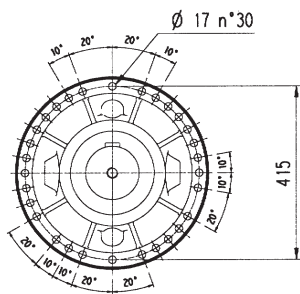
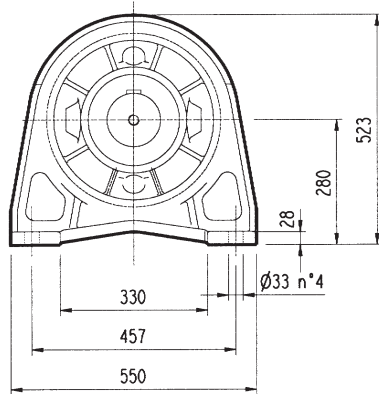

PC

HZ PZ

HC

FP

FZ

FP

$M_{2max} = 66\ 000\ \text{Nm}$

	L				Kg				Albero veloce / Input shaft / Antriebswelle / Arbre d'entrée					
	PC - PZ	HC - HZ	FZ	FP	PC - PZ	HC - HZ	FZ	FP	V	V1	Kg	V	V1	Kg
313 L1	381	154	154	154	320	230	200	200	343	80	55	-	-	-
313 L2	531	304	304	304	380	290	260	280	315	80	35	313	60	28
313 L3	620	393	393	393	392	302	272	292	239	48	15	-	-	-
313 L4	685	458	458	458	399	309	279	299	137.5	24	6	158	38	7

	P71		P80		P90		P100		P112		P132		P160		P180		P200		P225		P250M		
	E	P	E	P	E	P	E	P	E	P	E	P	E	P	E	P	E	P	E	P	E	P	
313 L1	-	-	-	-	-	-	-	-	-	-	-	-	-	-	-	-	-	-	-	-	-	-	
313 L2	-	-	-	-	-	-	-	-	-	-	-	-	-	195	350	186	400	216	450	216	550	-	-
313 L3	-	-	-	-	-	-	-	-	-	-	114	300	144	350	144	350	174	400	-	-	-	-	
313 L4	65	160	84	200	84	200	94	250	94	250	114	300	144	350	-	-	-	-	-	-	-	-	

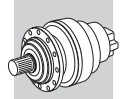

PC

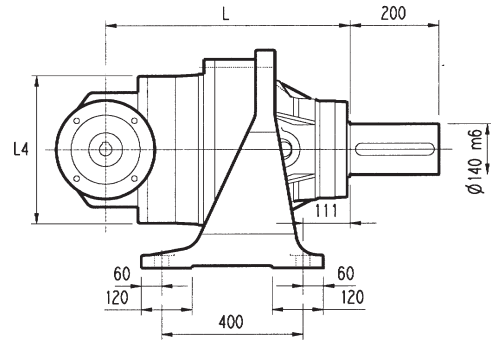
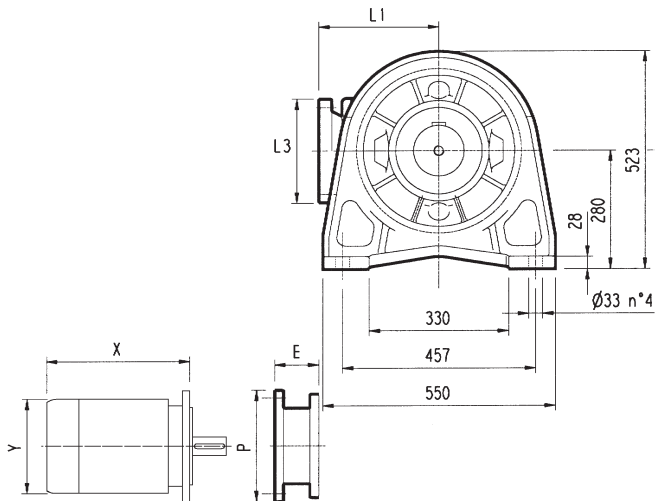

HZ PZ

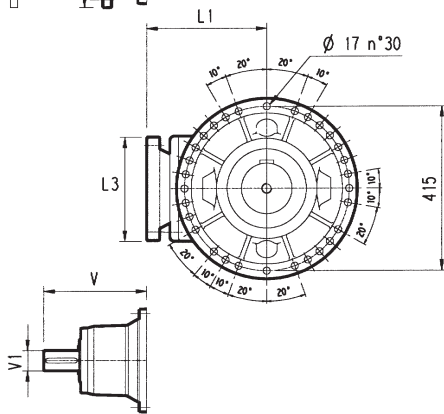
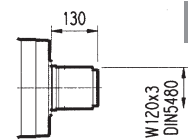

HC

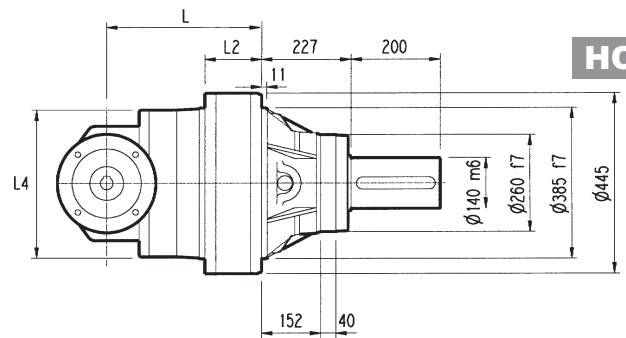

FP

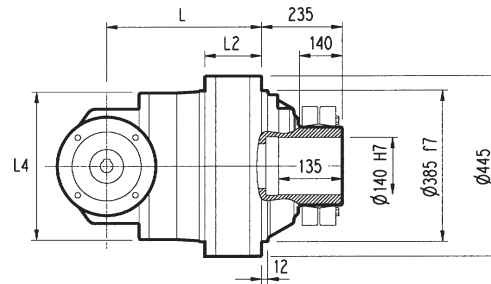

FZ

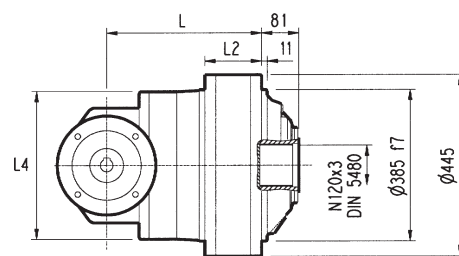

FP $M_{2max} = 66\ 000\ \text{Nm}$

	L				L1	L2				L3	L4	Kg				Albero veloce / Input shaft Antriebswelle / Arbre d'entrée					
	PC - PZ	HC - HZ	FZ	FP		HZ - HC	FZ	FP				PC - PZ	HC - HZ	FZ	FP	V	V1	Kg	V	V1	Kg
313 R2 (B)	611	384	384	384	345	199	199	199	292	400	450	360	330	350	307	60	23	-	-	-	
313 R2 (C)	611	384	384	384	390	168	168	168	292	480	460	370	340	360	307	60	23	-	-	-	
313 R2 (A)	611	384	384	384	330	199	199	199	245	390	430	340	310	330	239	48	15	-	-	-	
313 R3	650	423	423	423	225	169	169	169	245	345	430	340	310	330	239	48	15	-	-	-	
313 R4	712	485	485	485	140	169	169	169	186	244	412	322	292	312	137.5	24	6	158	38	7	

	P 71		P 80		P 90		P 100		P 112		P 132		P 160M		P 180		P 200L		P 225		P 250	
	E	P	E	P	E	P	E	P	E	P	E	P	E	P	E	P	E	P	E	P	E	P
313 R2 (B)	-	-	-	-	-	-	-	-	-	-	-	-	-	-	152	350	182	400	212	450	193	550
313 R2 (C)	-	-	-	-	-	-	-	-	-	-	-	-	-	-	152	350	182	400	212	450	193	550
313 R2 (A)	-	-	-	-	-	-	-	-	-	-	114	300	144	350	144	350	174	400	-	-	-	-
313 R3	-	-	-	-	-	-	-	-	-	-	114	300	144	350	144	350	174	400	-	-	-	-
313 R4	65	160	84	200	84	200	94	250	94	250	114	300	144	350	-	-	-	-	-	-	-	-

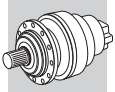

3/V 13L3

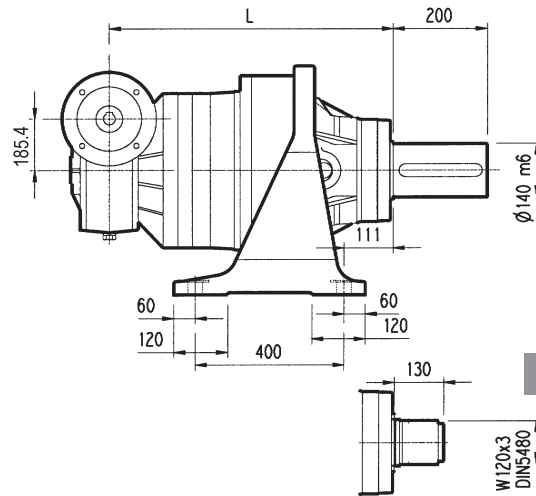
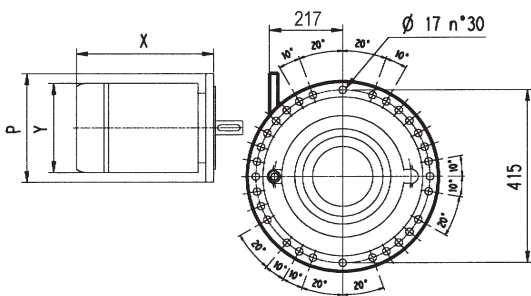
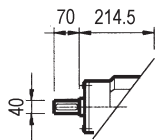
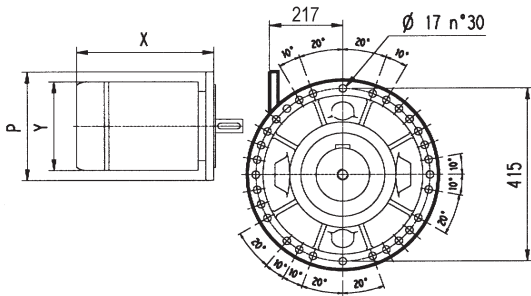
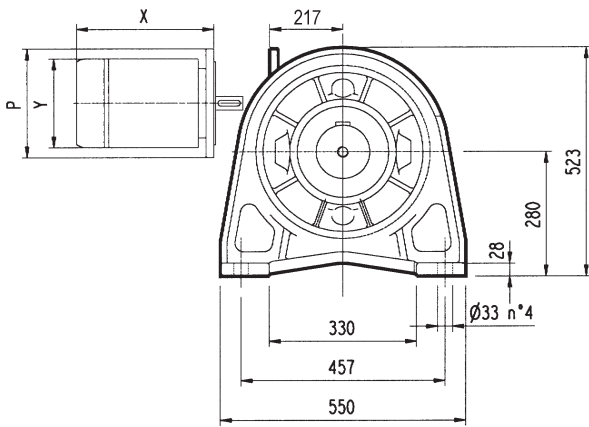

PC

HZ PZ

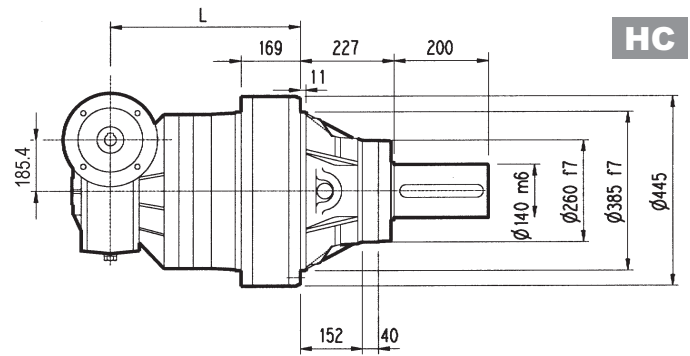

HC

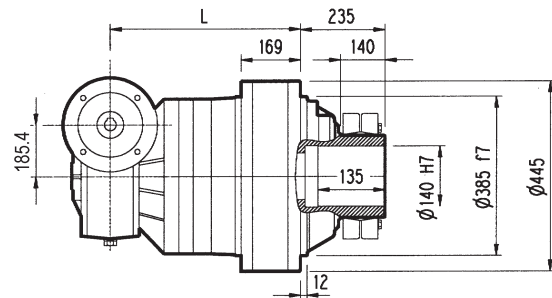

FP

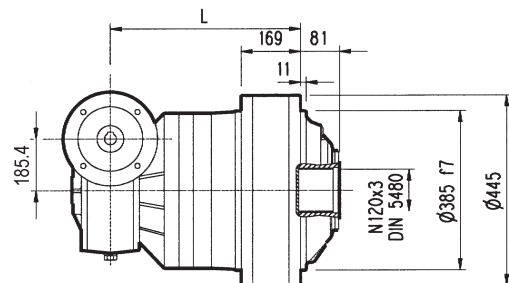

FZ

FP

$M_{2max} = 66\ 000\ \text{Nm}$

	L				Kg				P80	P90	P100	P112	P132	P160	P180
	PC - PZ	HC - HZ	FZ	FP	PC - PZ	HC - HZ	FZ	FP	P	P	P	P	P	P	P
3/V 13L3	732	505	505	505	475	385	355	375	-	-	250	250	300	350	350

3/V 13L4

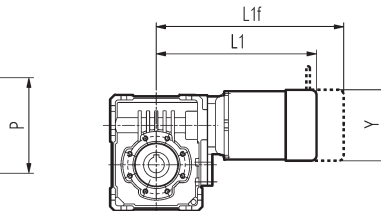
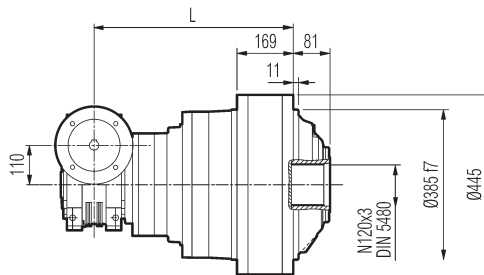
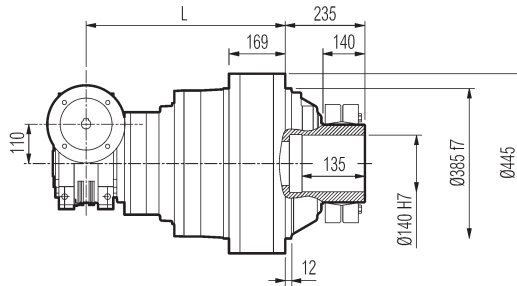
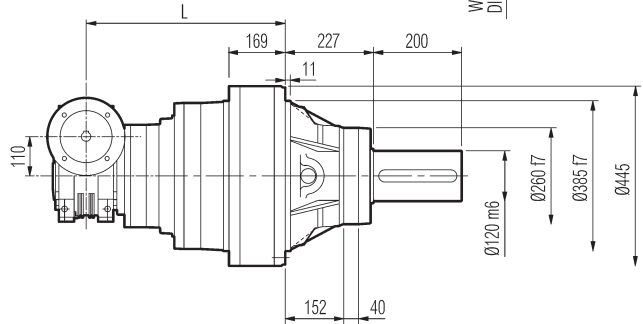
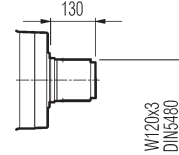
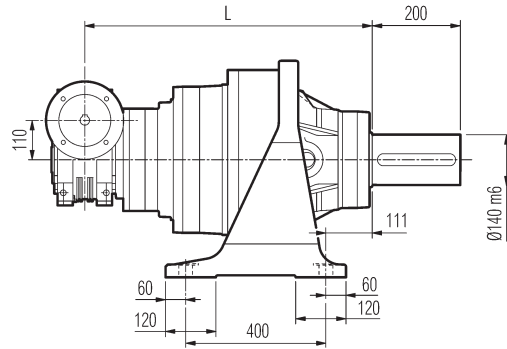
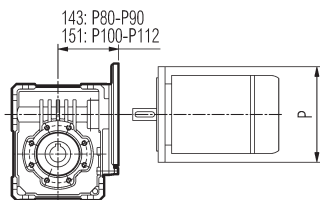
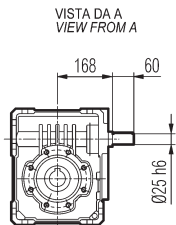
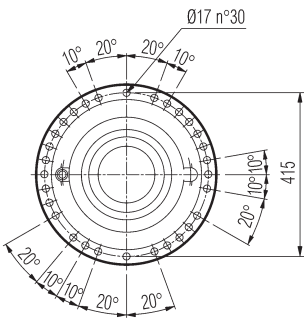
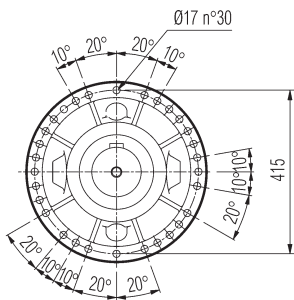
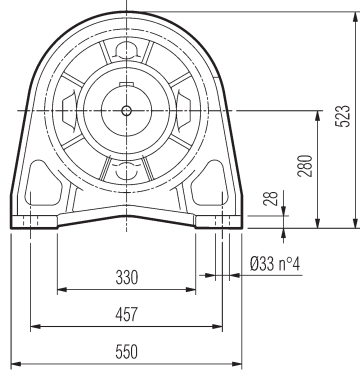
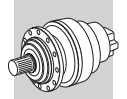

PC

HZ PZ

HC

FP

FZ

A

FP

$M_{2max} = 66\ 000\ Nm$

	L				L1	L2	L3	L4	L5	Kg			
	PC - PZ	HC - HZ	FZ	FP						PC - PZ	HC - HZ	FZ	FP
3/V 13L4	780	553	553	553	110.1	153	25	138	60	425	335	305	325

	P80	P90	P 100	P112	S2 - M2S			S3 - M3S			S3 - M3L		
	P	P	P	P	L1	L1f	Y	L1	L1f	Y	L1	L1f	Y
3/V 13L4	200	200	250	250	364	440	156	407	503	193	439	530	193

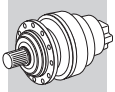

313 L

313 R

3/V 13L3

3/V 13L4

HC

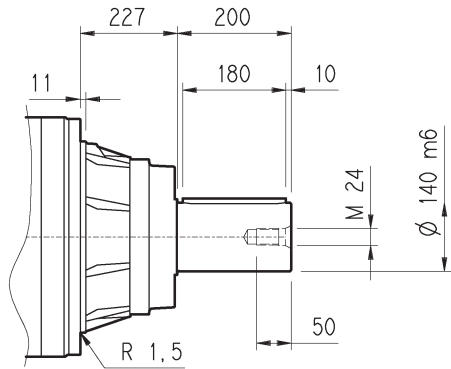

A 36x20x180
UNI 6604
DIN 6885

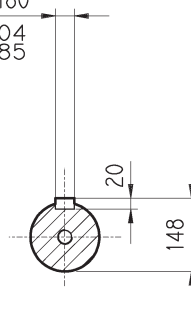

PC

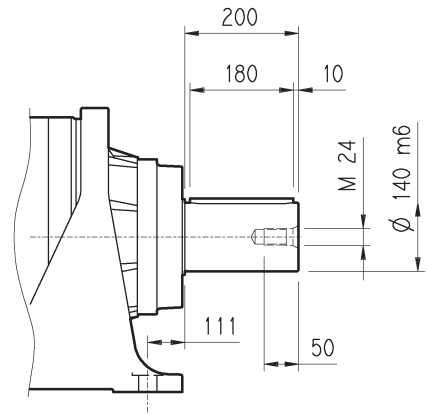

HZ

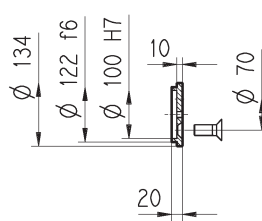
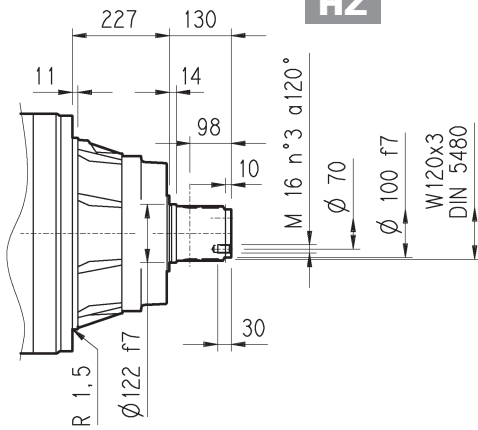

FZ

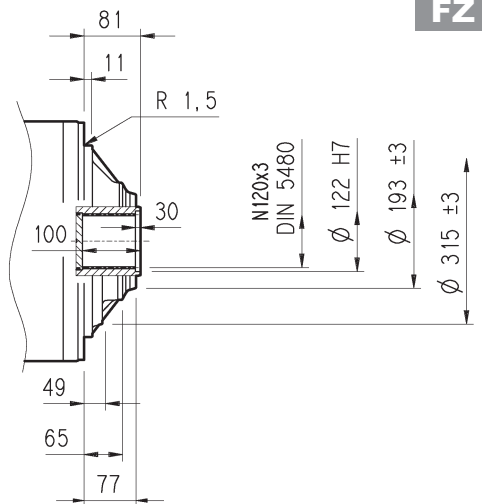

FP

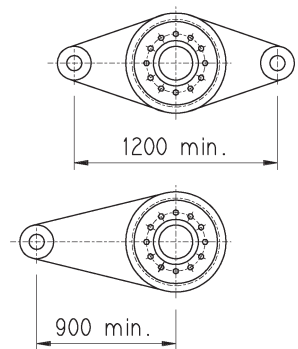
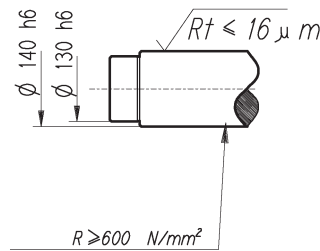
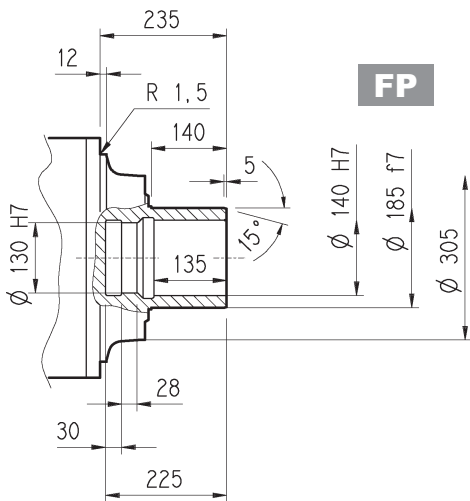

FP

$M_{2max} = 66\ 000\ Nm$

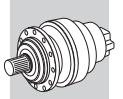

Flangia / Flange
Flansch / Brides

W0A

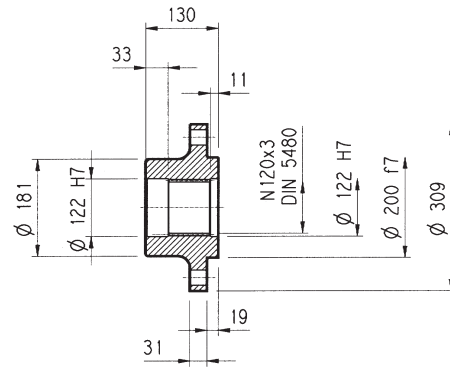
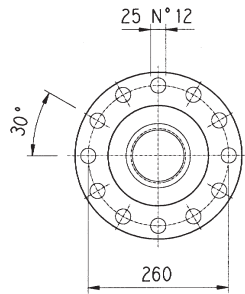
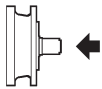

Materiale : Acciaio C40
Material : Steel C40
Material : Stahl C40
Màterial : Acier C40

Pignoni / Pinion gears
Ritzel / Pignons

P...

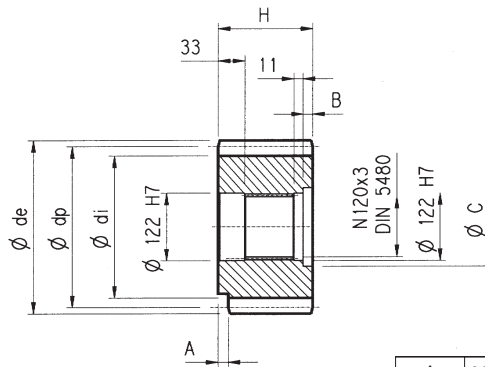
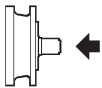

☆	Materiale / Material / Material / Matière
□	Acciaio 39NiCrMo3 Bonificato Steel 39NiCrMo3 hardened and tempered Vergüteter Stahl 39NiCrMo3 Acier bonifiée 39NiCrMo3
■	Acciaio 18NiCrMo5 Cementato e temprato Steel 18NiCrMo5 Case hardened Einsatzstahl 18NiCrMo5 Einsatzgehärtet Acier cimenté et tempré 18NiCrMo5

	m	z	x	dp	di	de	H	A	B	C	☆
PPH	16	17	0.500	272	247	315	135	0	5	136	□
PRI	18	18	0.333	324	294	365	140	0	10	140	□

Manicotti lisci / Sleeve couplings
Naben / Manchons lisses a cannelure interieure

MOA

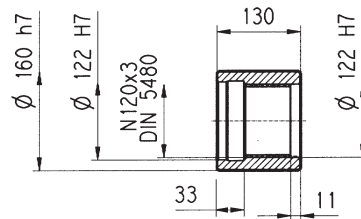
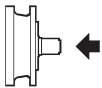

Materiale : Acciaio 16CrNi4
Material : Steel 16CrNi4
Material : Stahl 16CrNi4
Màterial : Acier 16CrNi4

Barre scanalate / Splined bars
Vielkeilwellen / Barre cannelée

B0A

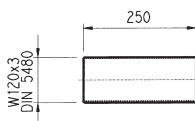
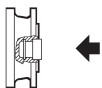

Mat. acciaio 18NiCrMo5 UNI 5331 da cementare e temprare 50-55 HRC
Case hardening steel 18NiCrMo5 UNI 5331 must be case hardened 50-55 HRC
Material: Einsatzstahl 18NiCrMo5 UNI 5331 muss einsatzgehärtet werden 50-55 HRC
Acier 18 NiCrMo5 UNI 5331 doit être cémenté trempé 50-55 HRC

Giunto ad attrito / Shrink disc
Schrumpfscheibe / Frette de serrage

G0A

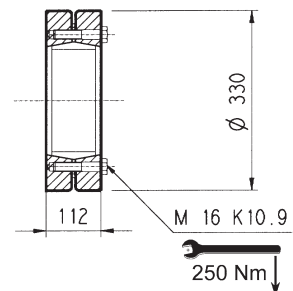
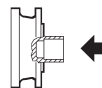

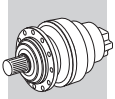

313 L

313 R

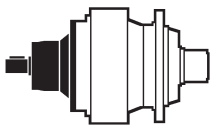
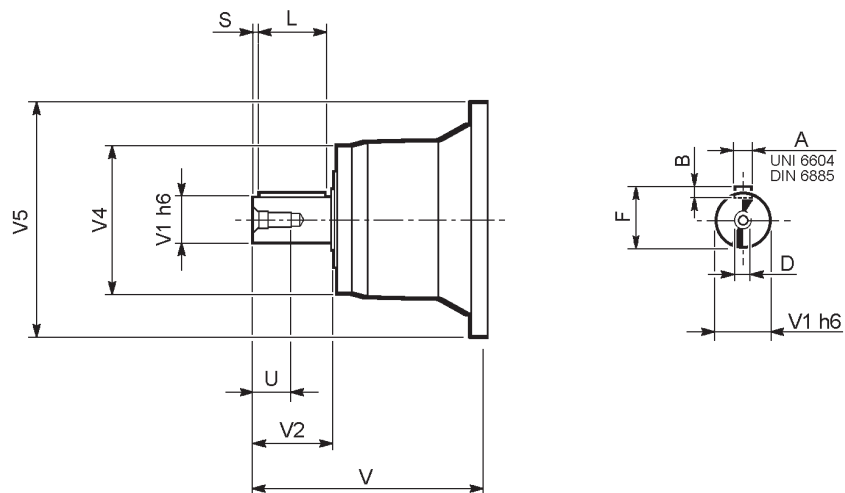

	CODE	V	V1	V2	V4	V5	A	B	F	L	S	D	U
313 L1	V11B	343	80	130	200	445	22	14	85	110	10	M16	36
313 L2	V07B	315	80	130	200	345	22	14	85	110	10	M16	36
	V07A	313	60	105	155	345	18	11	64	90	7.5	M16	36
313 L3	V05B	239	48	82	155	245	14	9	51.5	70	6	M16	36
313 L4	V01A	137.5	24	36	120	186	8	7	27	30	3	M8	19
	V01B	158	38	58	120	186	10	8	41	50	4	M12	28
313 R2 (A)	V05B	239	48	82	155	245	14	9	51.5	70	6	M16	36
313 R2 (B) (C)	V06B	307	60	105	155	292	18	11	64	90	7.5	M16	36
313 R3	V05B	239	48	82	155	245	14	9	51.5	70	6	M16	36
313 R4	V01A	137.5	24	36	120	186	8	7	27	30	3	M8	19
	V01B	158	38	58	120	186	10	8	41	50	4	M12	28

3/V 13L3

3/V 13L4

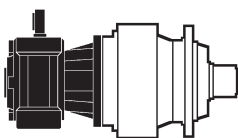
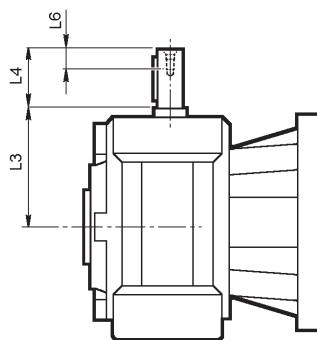
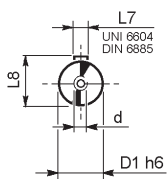

	D1 h6	L3	L4	L6	L7	L8	d
3/V 13L3_HS	40	214.5	70	20	12	43	M8
3/V 13L4_HS	25	168	60	19	8	28	M8

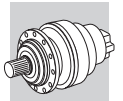

Fattore di posizione per carichi radiali sugli alberi in uscita.

Load location factor for radial loading on output shaft.

Positionsfaktor für Radialkräfte an der Abtriebswelle.

Facteur de position pour charges radiales sur les arbres en sortie.

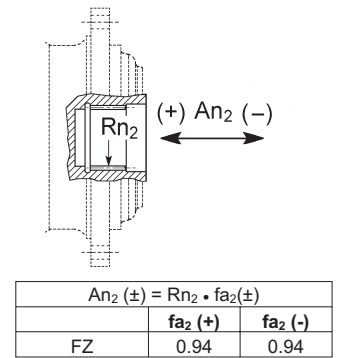
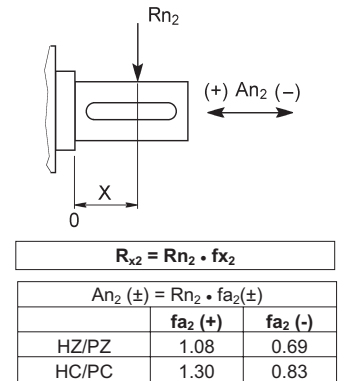
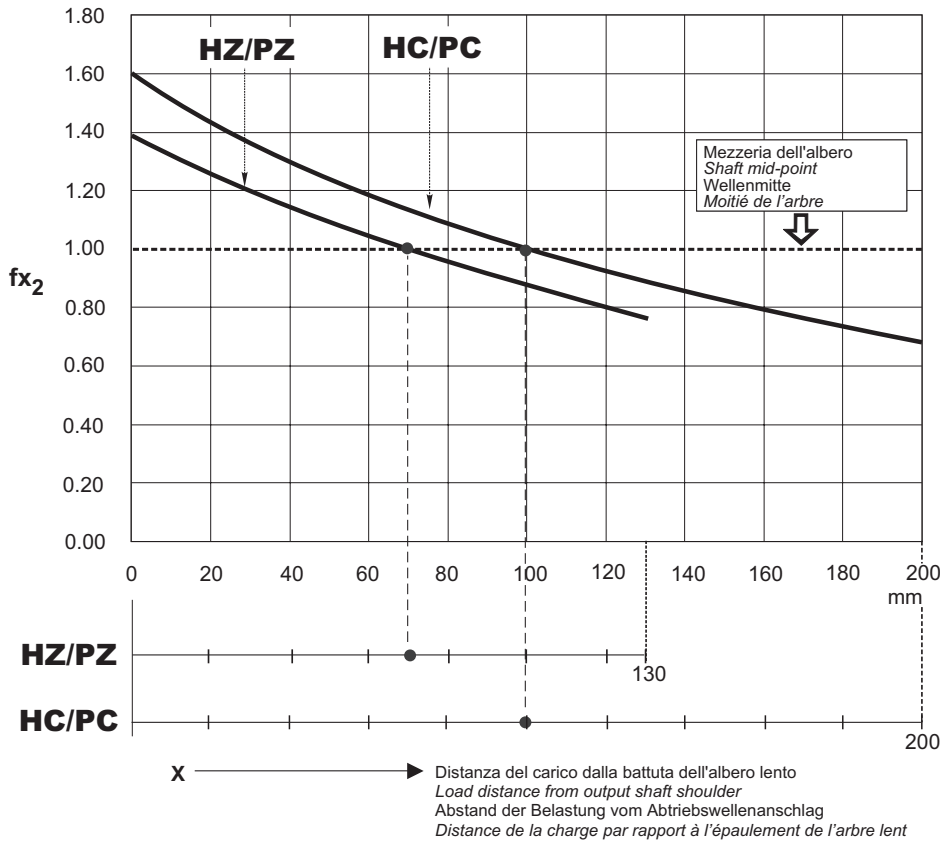

Carichi radiali ammissibili sull'albero veloce per $n_1 = 1000 \text{ min}^{-1}$ e 10000 h di vita teorica.

Permitted overhung loads on input shaft when $n_1 = 1000 \text{ min}^{-1}$ and theoretical lifetime = 10000 h.

Zulässige Radialkräfte an den Antriebswellen für $n_1 = 1000 \text{ min}^{-1}$ und 10000 std.

Charges radiales admissibles sur les arbres d'entrée pour $n_1 = 1000 \text{ min}^{-1}$ et 10000 h.

Per velocità di comando e/o durate diverse vedi il capitolo: Verifiche.

For drive speed and/or lifetimes other than those specified here, see Chapter: Verifications.

Im Hinblick auf Geschwindigkeit und/oder anderweitige Dauern verweisen wir auf Par: Prüfungen

Pour des vitesses et/ou durées différentes, voir par. Vérifications.

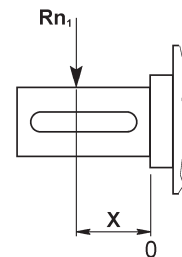
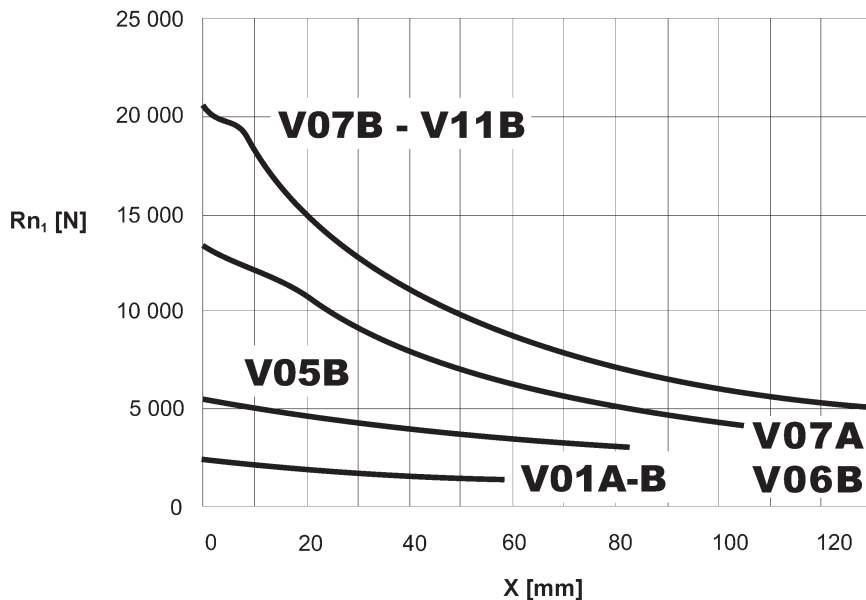

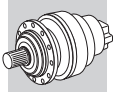

313_VK

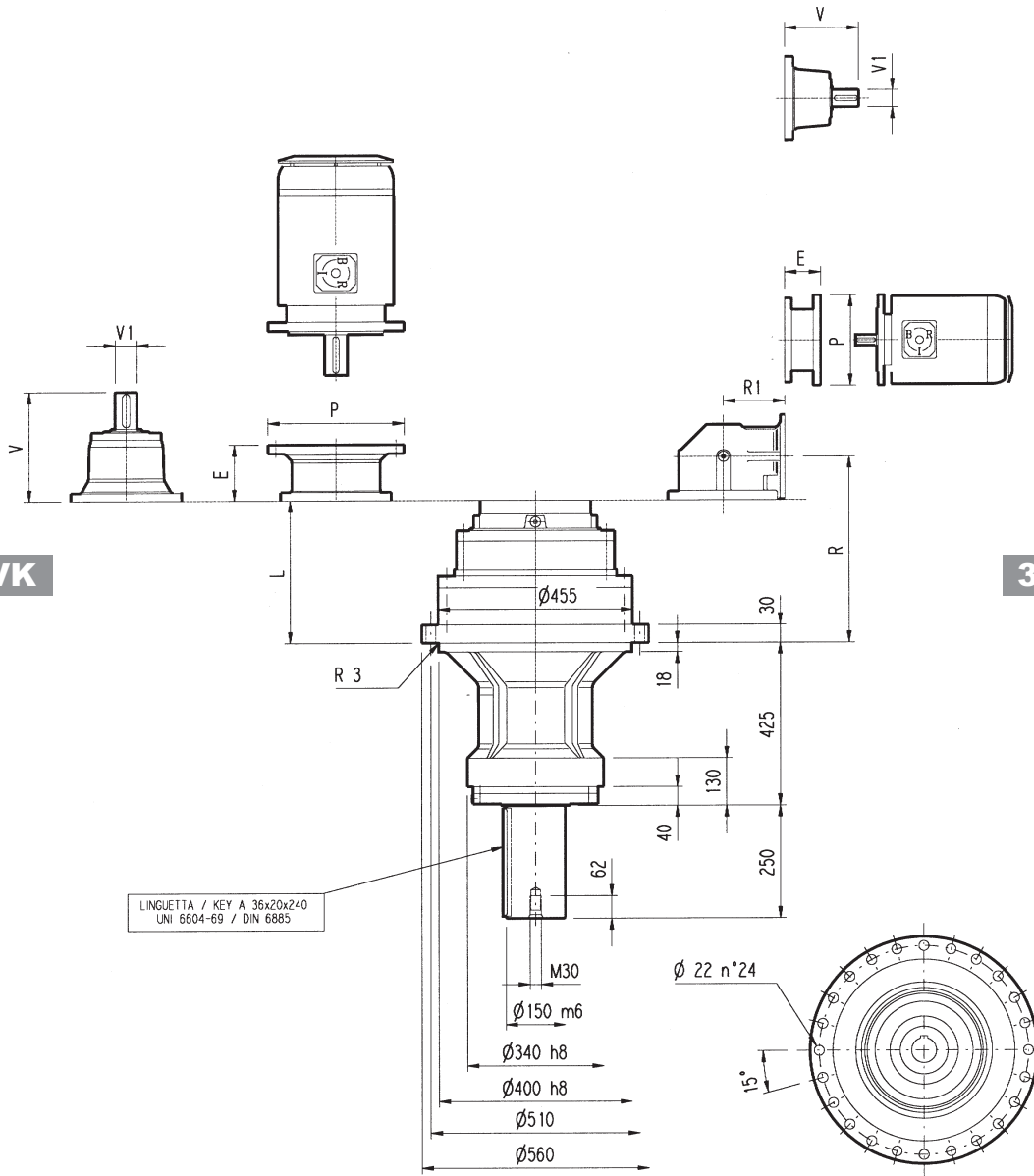

313 L_VK

313 R_VK

	L	Kg	Albero veloce / Input shaft / Antriebswelle / Arbre d'entrée					
			V	V1	Kg	V	V1	Kg
313 L1	158	380	343	80	55	-	-	-
313 L2	308	440	315	80	35	313	60	28
313 L3	397	450	239	48	15	-	-	-
313 L4	462	460	137.5	24	6	158	38	7

	P71		P80		P90		P100		P112		P132		P160		P180		P200L		P225		P250M	
	E	P	E	P	E	P	E	P	E	P	E	P	E	P	E	P	E	P	E	P	E	P
313 L1	-	-	-	-	-	-	-	-	-	-	-	-	-	-	-	-	-	-	-	-	-	-
313 L2	-	-	-	-	-	-	-	-	-	-	-	-	-	-	195	350	186	400	216	450	216	550
313 L3	-	-	-	-	-	-	-	-	-	-	114	300	144	350	144	350	174	400	-	-	-	-
313 L4	65	160	84	200	84	200	94	250	94	250	114	300	-	-	-	-	-	-	-	-	-	-

	R	R1	Kg	Albero veloce / Input shaft / Antriebswelle / Arbre d'entrée					
				V	V1	Kg	V	V1	Kg
313 R2 (B)	388	345	510	307	60	23	-	-	-
313 R2 (C)	388	390	520	307	60	23	-	-	-
313 R2 (A)	388	330	490	239	48	15	-	-	-
313 R3	427	225	490	239	48	15	-	-	-
313 R4	489	140	470	137.5	24	6	158	38	7

	P71		P80		P90		P100		P112		P132		P160M		P180		P200L		P225		P250	
	E	P	E	P	E	P	E	P	E	P	E	P	E	P	E	P	E	P	E	P	E	P
313 R2 (B)	-	-	-	-	-	-	-	-	-	-	-	-	-	-	152	350	182	400	212	450	193	550
313 R2 (C)	-	-	-	-	-	-	-	-	-	-	-	-	-	-	152	350	182	400	212	450	193	550
313 R2 (A)	-	-	-	-	-	-	-	-	-	-	114	300	144	350	144	350	174	400	-	-	-	-
313 R3	-	-	-	-	-	-	-	-	-	-	114	300	144	350	144	350	-	-	-	-	-	-
313 R4	65	160	84	200	84	200	94	250	94	250	114	300	144	350	-	-	-	-	-	-	-	-

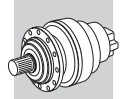

Il diagramma seguente consente di ricavare il carico radiale ammissibile R_{x2} quando questo è applicato alla distanza x dallo spallamento dell'albero lento del riduttore 313_VK.

Le curve si riferiscono al valore risultante dal rapporto fra il carico assiale A_{n2} e il carico radiale R_{n2} , entrambi riferiti a $n_2 = 10 \text{ min}^{-1}$ e durata teorica di 10000 h.

The diagram below allows the calculation of permitted overhung load R_{x2} on the output shaft of gearbox type 313_VK, with radial force applying at a distance x from shaft shoulder.

The curves are relevant to value resulting from the relationship of trust load A_{n2} to radial load R_{n2} , based on $n_2 = 10 \text{ min}^{-1}$ and 10000 hrs theoretical lifetime.

Das nachstehende Diagramm ermöglicht das Individuieren der zulässigen, auf die Welle des Getriebes 313_VK einwirkenden Radialkraft, die auf der Distanz x vom Anschlag der Welle selbst appliziert wird.

Die Kurven beziehen sich auf den Wert, der sich aus dem Verhältnis zwischen der Axialkraft A_{n2} und der Radialkraft R_{n2} für $n_2 = 10 \text{ min}^{-1}$ und einer Dauer von 10000 Std. ergibt.

Le diagramme suivant permet de déterminer la charge radiale admissible R_{x2} sur l'arbre lent du réducteur 313_VK appliqué à la distance x de l'épaule de l'arbre.

Les courbes se réfèrent à la valeur résultant de l'équation entre la charge axiale A_{n2} et la charge radiale R_{n2} pour $n_2 = 10 \text{ min}^{-1}$ et durée de 10000 h.

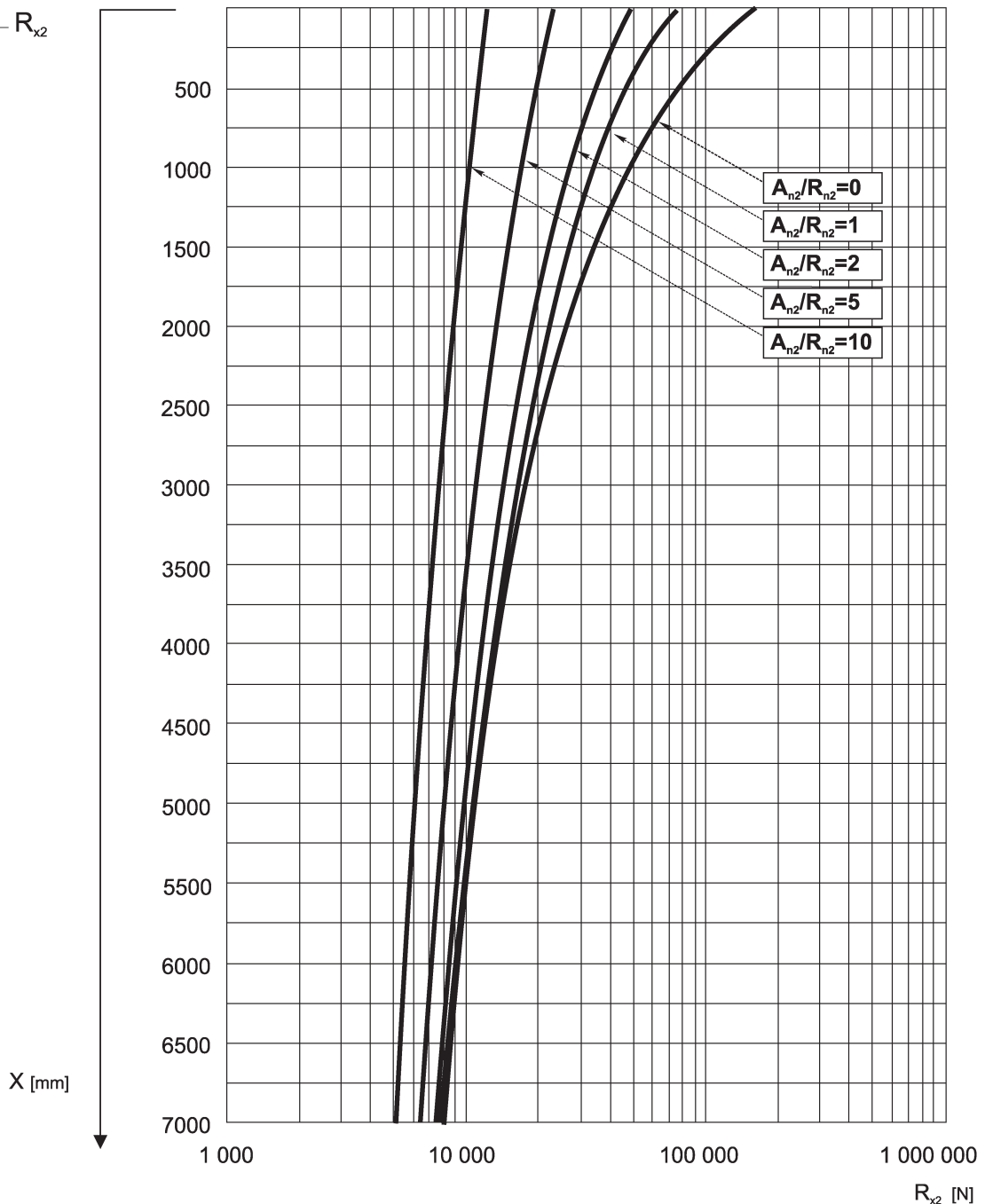
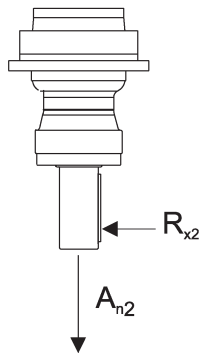

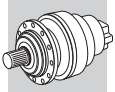

315 L

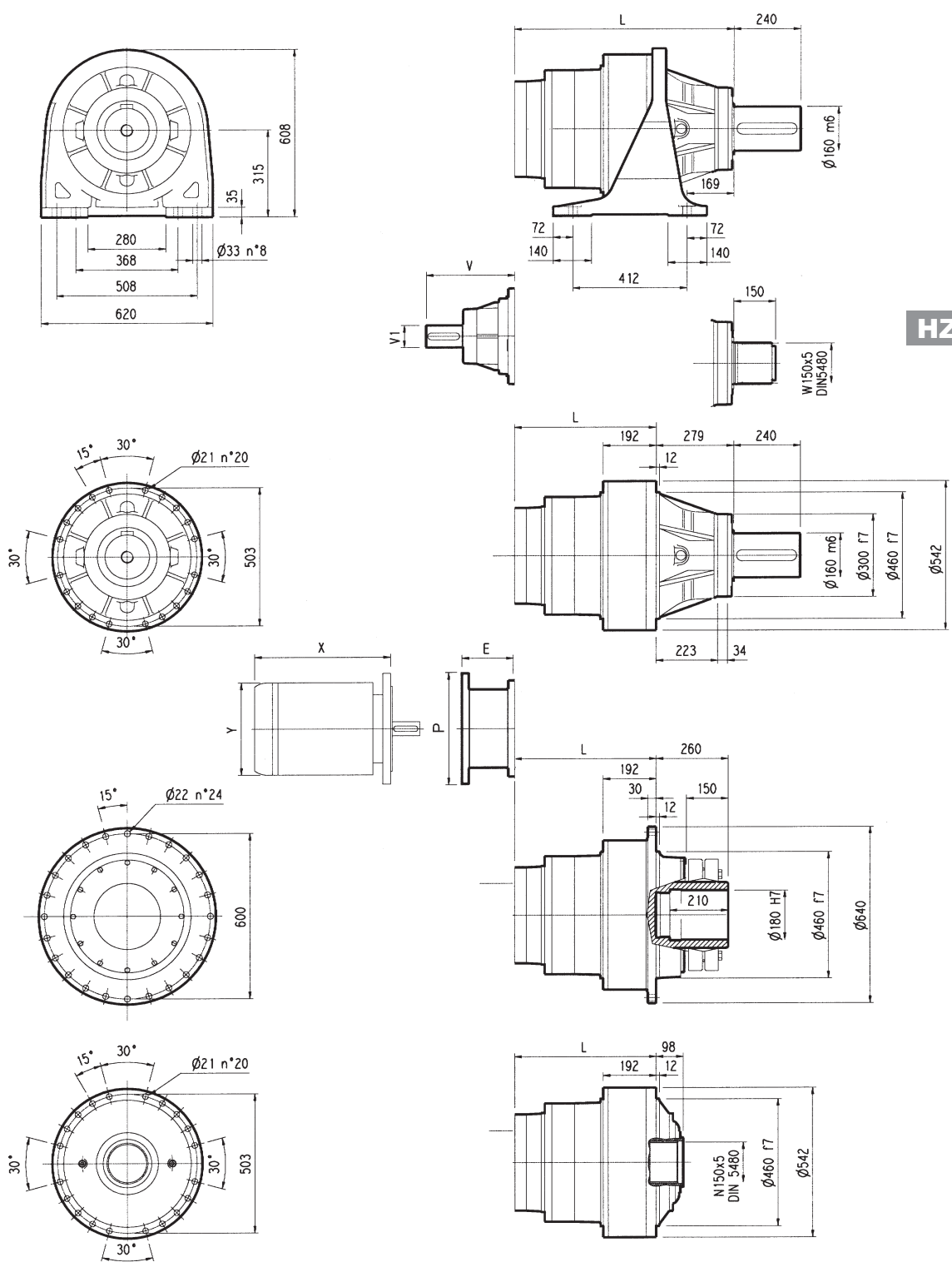

PC

HZ PZ

HC

FP

FZ

FP $M_{2max} = 126\ 000\ Nm$

	L				Kg				Albero veloce / Input shaft Antriebswelle / Arbre d'entrée					
	PC - PZ	HC - HZ	FZ	FP	PC - PZ	HC - HZ	FZ	FP	V	V1	Kg	V	V1	Kg
315 L2	665	386	386	386	585	455	365	415	348	80	55	-	-	-
315 L3	798	519	519	519	630	500	410	460	315	80	35	313	60	28
315 L4	887	608	608	608	642	512	422	472	239	48	15	-	-	-

	P132		P160		P180		P200		P225	
	E	P	E	P	E	P	E	P	E	P
315 L2	-	-	-	-	-	-	-	-	-	-
315 L3	-	-	-	-	195	350	186	400	216	450
315 L4	114	300	144	350	144	350	-	-	-	-

315 R

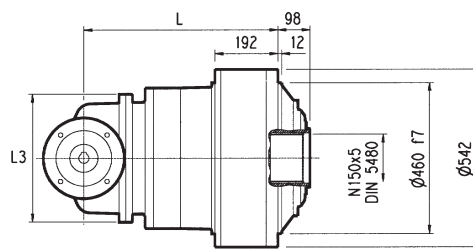
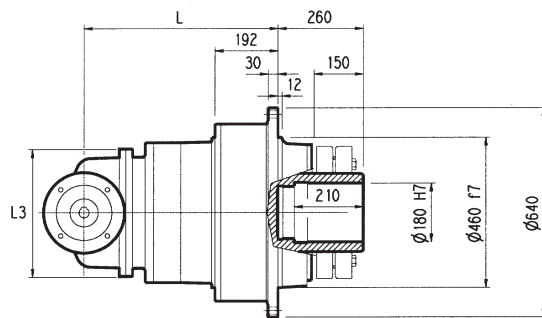
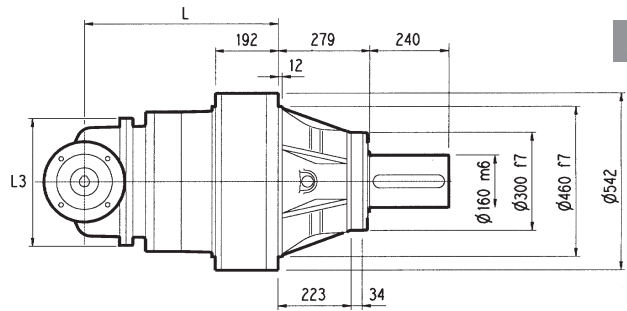
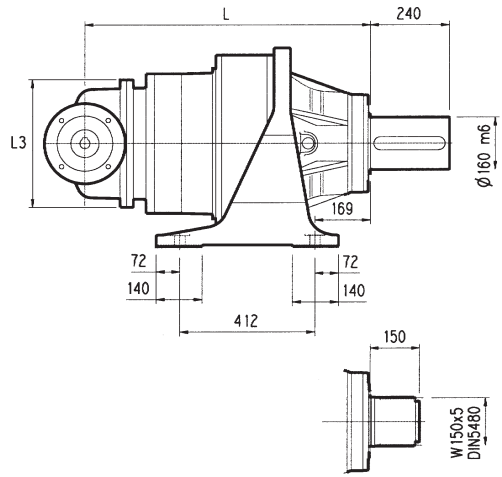
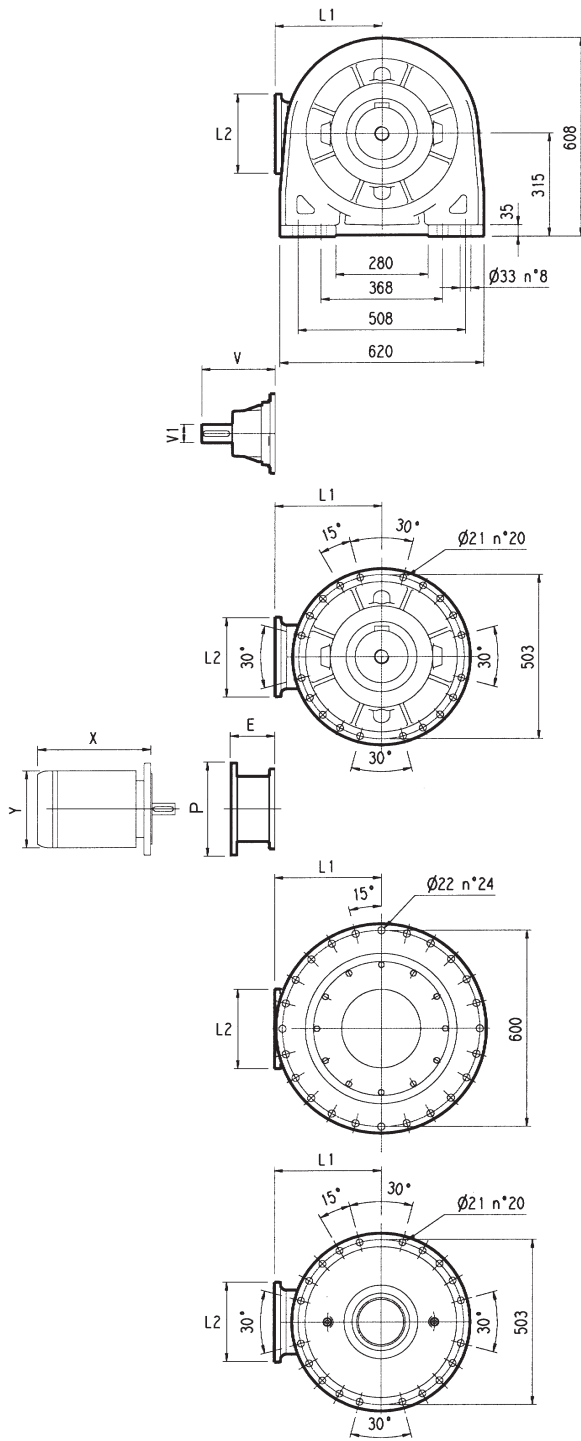
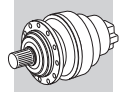

PC

HZ PZ

HC

FP

FZ

FP

$M_{2max} = 126\ 000\ \text{Nm}$

	L				L1	L2	L3	Kg				Albero veloce / Input shaft Antriebswelle / Arbre d'entrée					
	PC - PZ	HC - HZ	FZ	FP				PC - PZ	HC - HZ	FZ	FP	V	V1	Kg	V	V1	Kg
315 R3 (B)	890	611	611	611	345	292	400	720	590	500	550	307	60	23	-	-	-
315 R3 (C)	890	611	611	611	390	292	480	730	600	510	560	307	60	23	-	-	-
315 R3 (A)	890	611	611	611	330	245	390	695	565	475	525	239	48	15	-	-	-
315 R4	917	638	638	638	225	245	345	680	550	460	510	239	48	15	-	-	-

	P132		P160M		P180		P200L		P225		P250	
	E	P	E	P	E	P	E	P	E	P	E	P
315 R3 (B)	-	-	-	-	152	350	182	400	212	450	193	550
315 R3 (C)	-	-	-	-	152	350	182	400	212	450	193	550
315 R3 (A)	114	300	144	350	144	350	174	400	-	-	-	-
315 R4	114	300	144	350	144	350	174	400	-	-	-	-

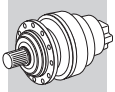

3/V 15L3

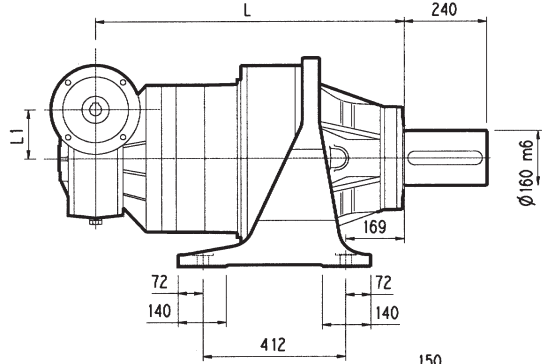
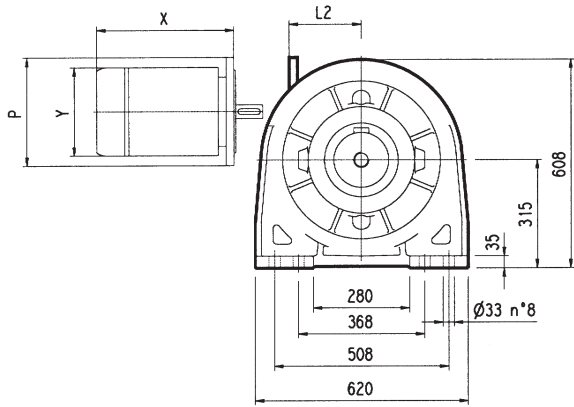

PC

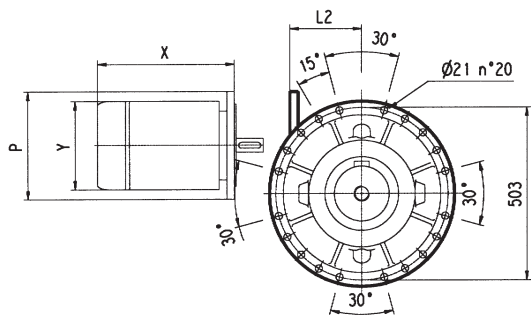

HZ PZ

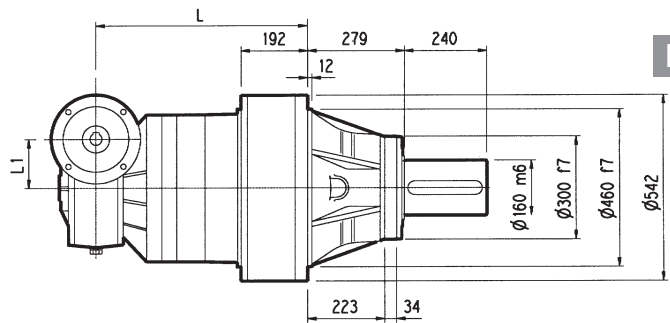

HC

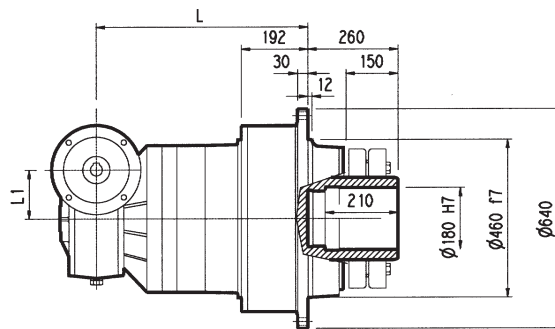
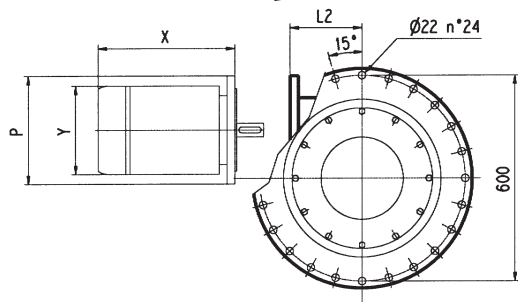
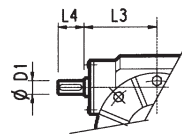

FP

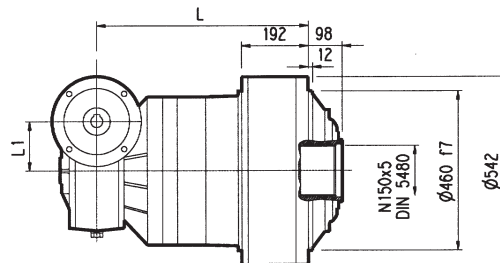
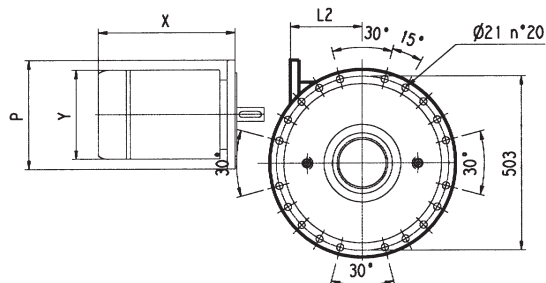

FZ

FP

$M_{2max} = 126\,000 \text{ Nm}$

	L				L1	L2	D1	L3	L4	Kg			
	PC - PZ	HC - HZ	FZ	FP						PC - PZ	HC - HZ	FZ	FP
3/V 15L3	885	606	606	606	210	-	48	230	110	800	670	575	625

3/V 15L3	P100	P112	P132		P160		P180		P200		P225	
	P	P	L2	P	L2	P	L2	P	L2	P	L2	P
	-	-	485	300	460	350	460	350	485	400	490	450

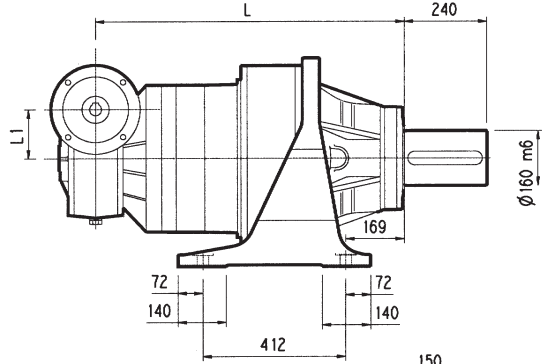
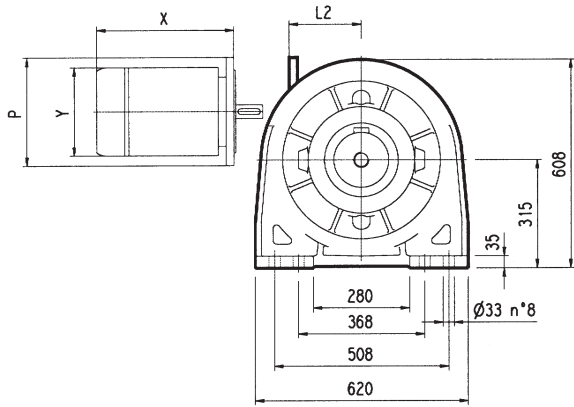
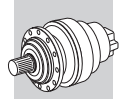

PC

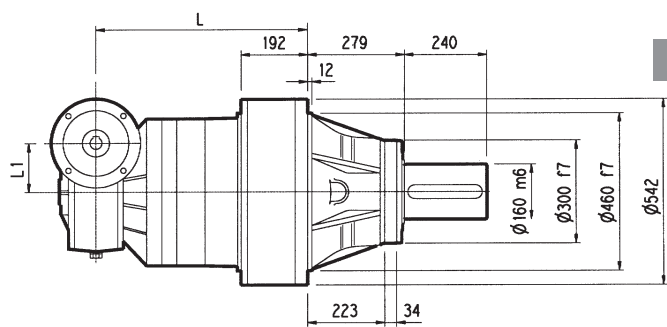
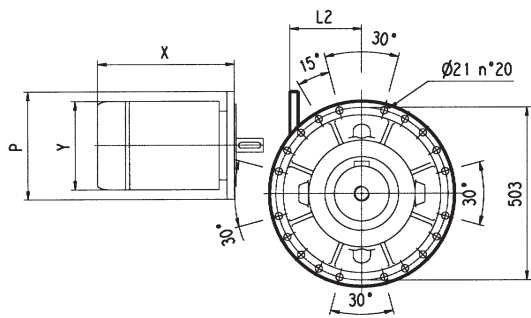

HC

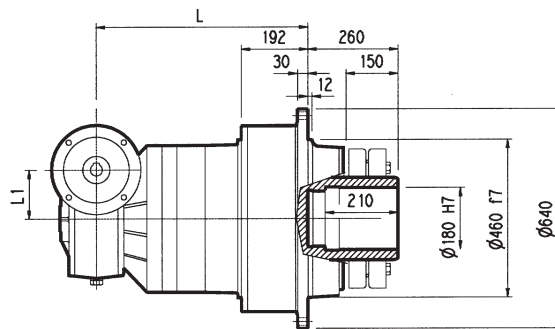
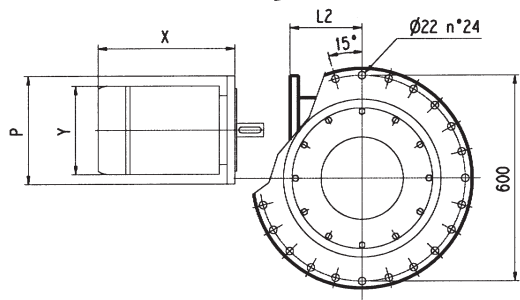
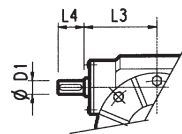

FP

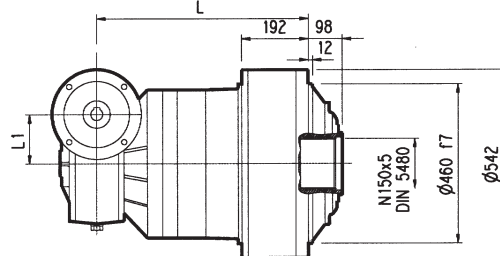
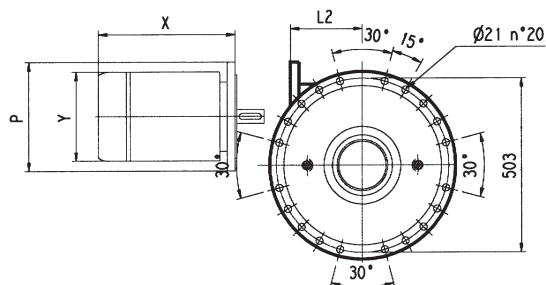

FZ

FP

$M_{2max} = 126\ 000\ Nm$

	L				L1	L2	D1	L3	L4	Kg				
	PC - PZ	HC - HZ	FZ	FP							PC - PZ	HC - HZ	FZ	FP
3/V 15L4	989	710	710	710	150	190	35	185	65		690	560	470	520

	P100	P112	P132		P160		P180		P200		P225	
	P	P	L2	P	L2	P	L2	P	L2	P	L2	P
3/V 15L4	250	250	-	300	-	350	-	-	-	-	-	-

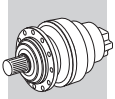

315 L

315 R

3/V 15L3

3/V 15L4

HC

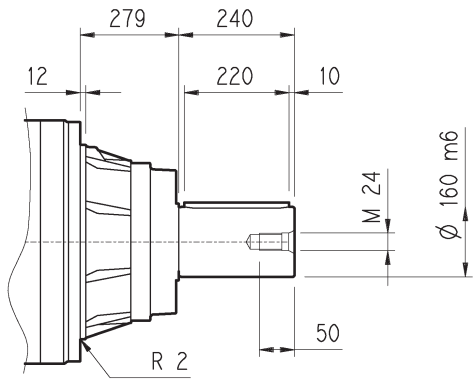

A 40x22x220
UNI 6604
DIN 6885

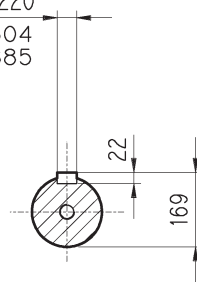

PC

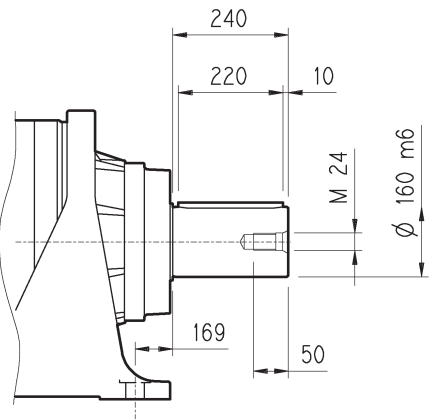

HZ

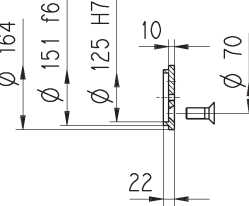
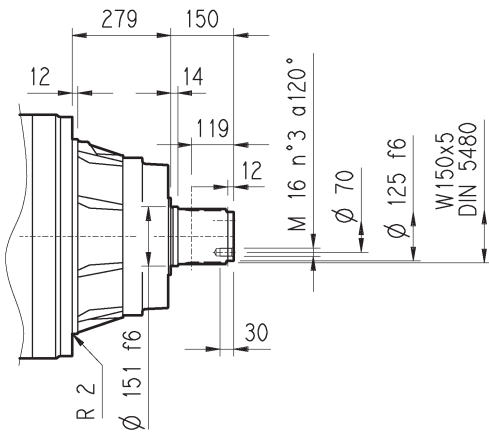

FZ

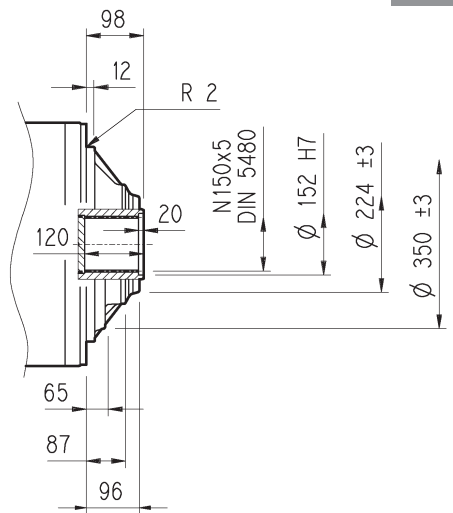

FP

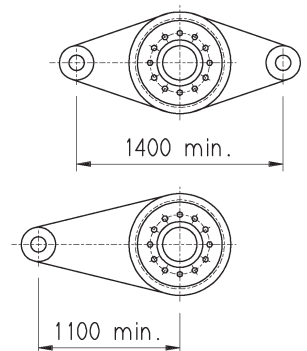
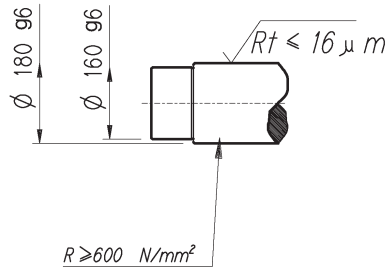
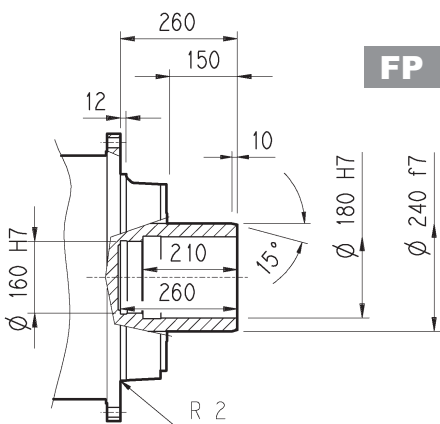

FP

M_{2max} = 126 000 Nm

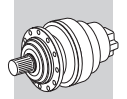
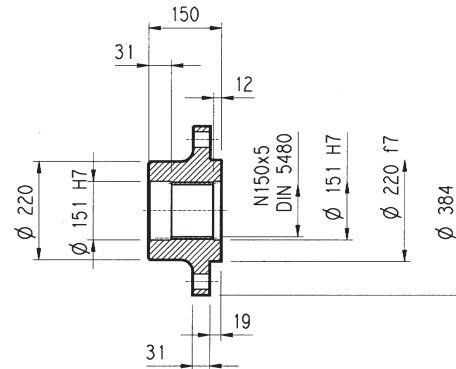
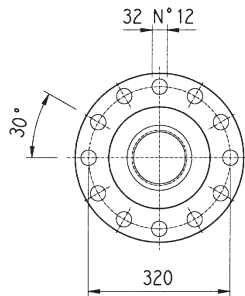
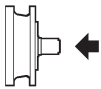
315 L**315 R****3/V 15L3****3/V 15L4**
Flangia / Flange
Flansch / Brides
W0A
 Materiale : Acciaio C40
 Material : Steel C40
 Material : Stahl C40
 Matière : Acier C40

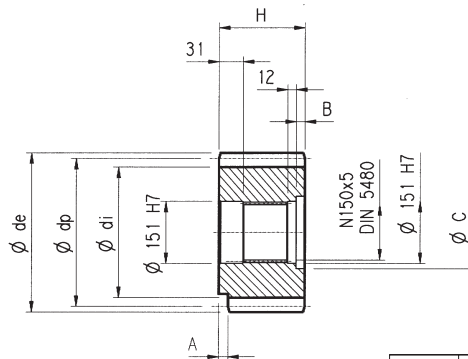
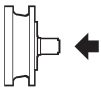
Pignoni / Pinion gears
Ritzel / Pignons
P...

	m	z	x	dp	di	de	H	A	B	C	☆
PRG1	18	16	0.500	288	261	342	160	0	10	166	■
PRG2	18	16	0.617	288	271	339	150	30	0	0	□

☆	Materiale / Material / Material / Matière
□	Acciaio 39NiCrMo3 Bonificato Steel 39NiCrMo3 hardened and tempered Vergüteter Stahl 39NiCrMo3 Acier bonifiée 39NiCrMo3
■	Acciaio 18NiCrMo5 Cementato e temprato Steel 18NiCrMo5 Case hardened Einsatzstahl 18NiCrMo5 Einsatzgehärtet Acier cémenté et tempré 18NiCrMo5

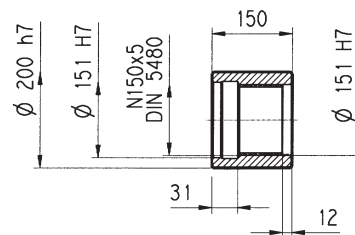
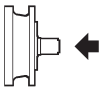
Manicotti lisci / Sleeve couplings
Naben / Manchons lisses a cannelure interieure
MOA
 Materiale : Acciaio 16CrNi4
 Material : Steel 16CrNi4
 Material : Stahl 16CrNi4
 Matière : Acier 16CrNi4

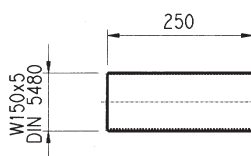
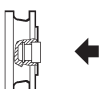
Barre scanalate / Splined bars
Vielkeilwellen / Barre cannelée
B0A
 Mat. acciaio 18NiCrMo5 UNI 5331 da cementare e
 temprare 50-55 HRC
 Case hardening steel 18NiCrMo5 UNI 5331 must be case
 hardened 50-55 HRC
 Material: Einsatzstahl 18NiCrMo5 UNI 5331 muss einsatzgehärtet
 werden 50-55 HRC
 Acier 18 NiCrMo5 UNI 5331 doit être cémenté trempé 50-55 HRC

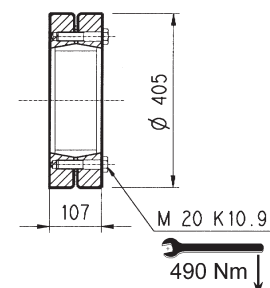
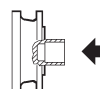
Giunto ad attrito / Shrink disc
Schrumpfscheibe / Frette de serrage
GOA

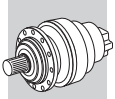

315 L

315 R

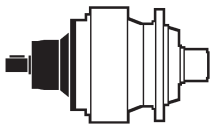
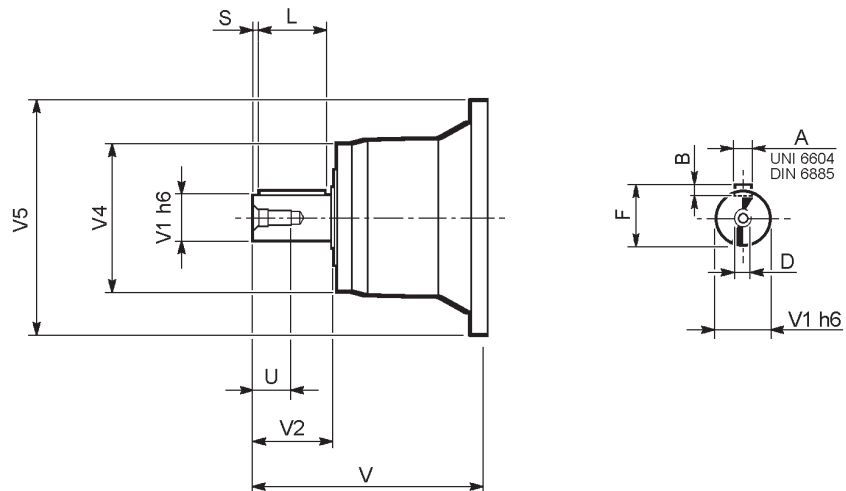

	CODE	V	V1	V2	V4	V5	A	B	F	L	S	D	U
315 L2	V11B	348	80	130	200	418	22	14	85	110	10	M16	36
315 L3	V07B	315	80	130	200	345	22	14	85	110	10	M16	36
	V07A	313	60	105	155	345	18	11	64	90	7.5	M16	36
315 L4	V05B	239	48	82	155	245	14	9	51.5	70	6	M16	36
315 R3 (A) - R4	V05B	239	48	82	155	245	14	9	51.5	70	6	M16	36
315 R3 (B) - (C)	V06B	307	60	105	155	292	18	11	64	90	7.5	M16	36

3/V 15L3

3/V 15L4

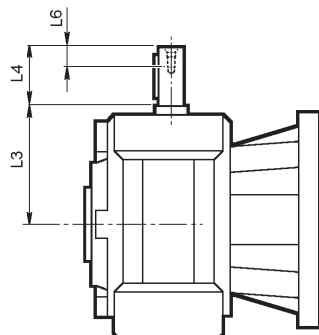
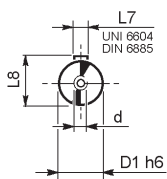

	D1 h6	L3	L4	L6	L7	L8	d
3/V 15L3 HS	48	230	110	40	14	51.5	M16
3/V 15L4 HS	35	185	65	20	10	38	M8

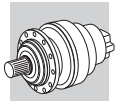

Fattore di posizione per carichi radiali sugli alberi in uscita.

Load location factor for radial loading on output shaft.

Positionsfaktor für Radialkräfte an der Abtriebswelle.

Facteur de position pour charges radiales sur les arbres en sortie.

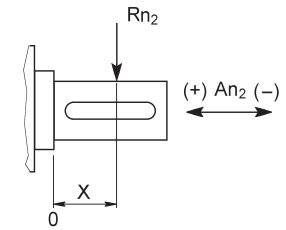
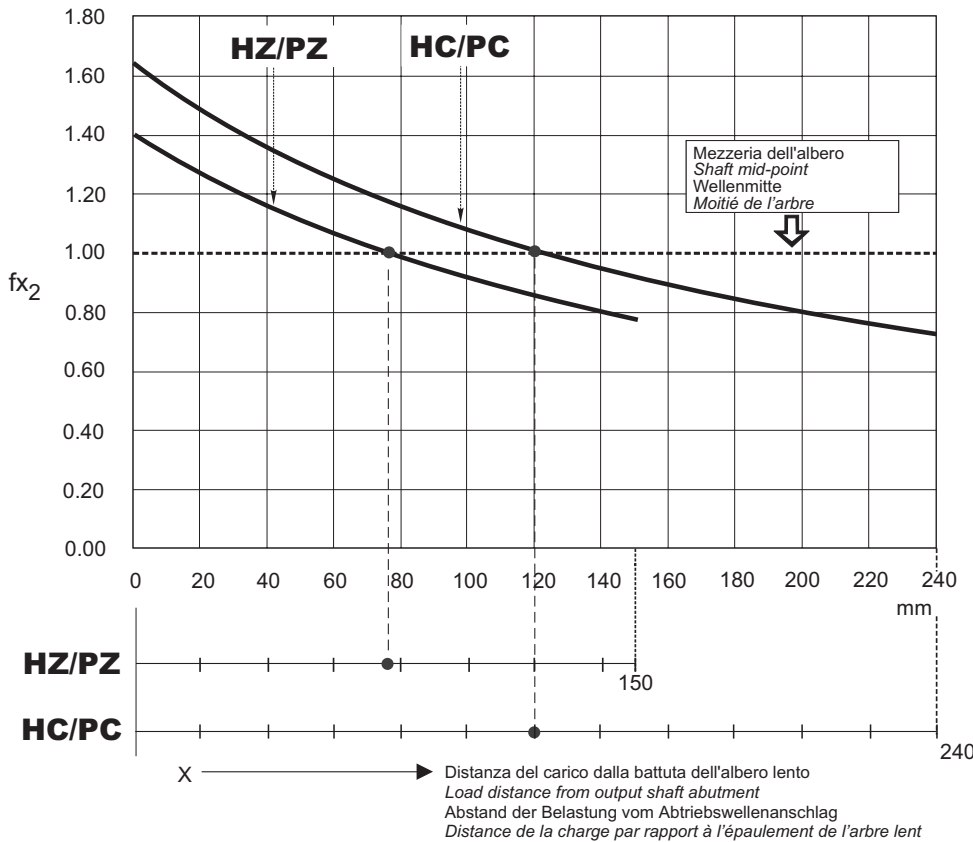

$$R_{x2} = R_{n2} \cdot f_{x2}$$

$$A_{n2} (\pm) = R_{n2} \cdot f_{a2} (\pm)$$

	$f_{a2} (+)$	$f_{a2} (-)$
HZ/PZ	1.15	0.86
HC/PC	1.36	1.02

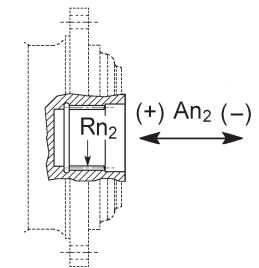

$$A_{n2} (\pm) = R_{n2} \cdot f_{a2} (\pm)$$

	$f_{a2} (+)$	$f_{a2} (-)$
FZ	1.00	1.00

Carichi radiali ammissibili sull'albero veloce per $n_1 = 1000 \text{ min}^{-1}$ e 10000 h di vita teorica. Per velocità di comando e/o durate diverse vedi il capitolo: Verifiche.

Permitted overhung loads on input shaft when $n_1 = 1000 \text{ min}^{-1}$ and theoretical lifetime = 10000 h. For drive speed and/or lifetimes other than those specified here, see Chapter: Verifications.

Zulässige Radialkräfte an den Antriebswellen für $n_1 = 1000 \text{ min}^{-1}$ und 10000 std. Im Hinblick auf Geschwindigkeit und/oder anderweitige Dauern verweisen wir auf Par: Prüfungen

Charges radiales admissibles sur les arbres d'entrée pour $n_1 = 1000 \text{ min}^{-1}$ et 10000 h. Pour des vitesses et/ou durées différentes, voir par. Vérifications.

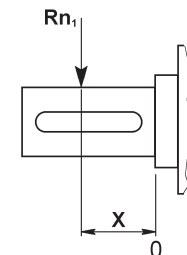
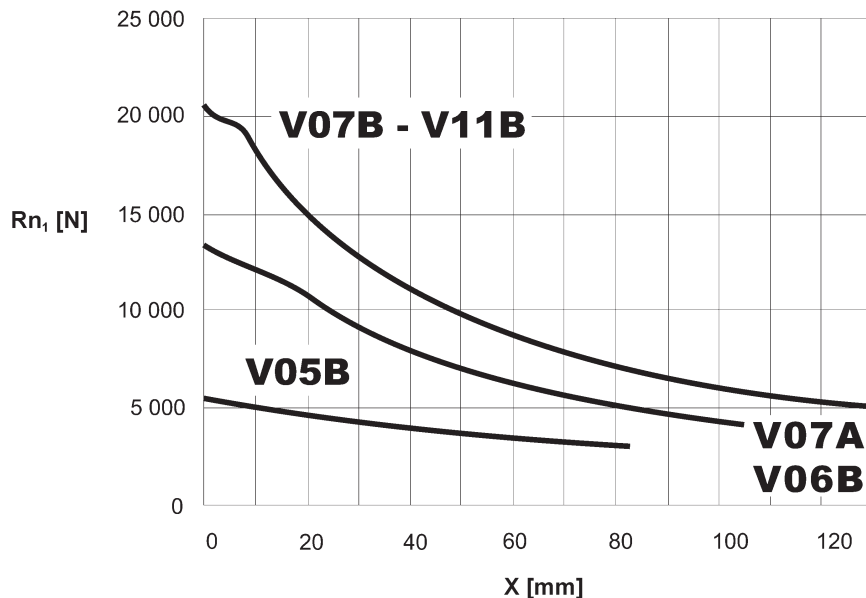

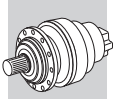

315_VK

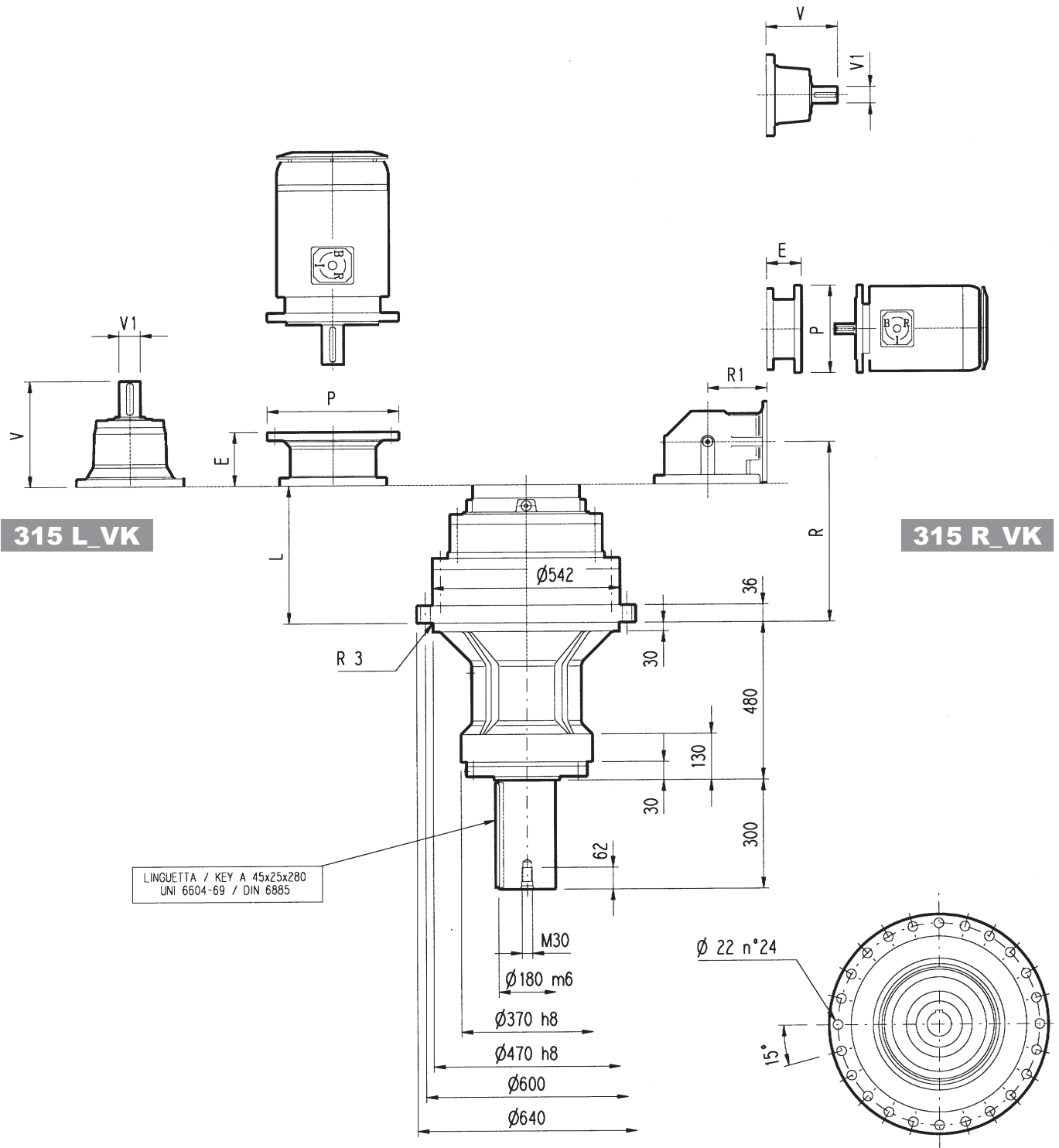

	L	Kg	Albero veloce / Input shaft Antriebswelle / Arbre d'entrée						P132		P160		P180		P200L		P225		P250M	
			V	V1	Kg	V	V1	Kg	E	P	E	P	E	P	E	P	E	P	E	P
315 L2	386	650	348	80	55	-	-	-	-	-	-	-	-	-	-	-	-	-	-	-
315 L3	519	700	315	80	35	313	60	28	-	-	-	-	195	350	186	400	216	450	216	550
315 L4	608	710	239	48	15	-	-	-	114	300	144	350	144	350	-	-	-	-	-	-

	R	R1	Kg	Albero veloce / Input shaft Antriebswelle / Arbre d'entrée						P132		P160M		P180		P200L		P225		P250	
				V	V1	Kg	V	V1	Kg	E	P	E	P	E	P	E	P	E	P	E	P
315 R3 (B)	611	345	720	307	60	23	-	-	-	-	-	-	152	350	182	400	212	450	193	550	
315 R3 (C)	611	390	730	307	60	23	-	-	-	-	-	-	152	350	182	400	212	450	193	550	
315 R3 (A)	611	330	700	239	48	15	-	-	-	114	300	144	350	144	350	174	400	-	-	-	-
315 R4	638	225	690	239	48	15	-	-	-	114	300	144	350	144	350	174	400	-	-	-	-

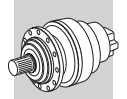

Il diagramma seguente consente di ricavare il carico radiale ammissibile R_{x2} quando questo è applicato alla distanza x dallo spallamento dell'albero lento del riduttore 315_VK.

Le curve si riferiscono al valore risultante dal rapporto fra il carico assiale A_{n2} e il carico radiale R_{n2} , entrambi riferiti a $n_2 = 10 \text{ min}^{-1}$ e durata teorica di 10000 h.

The diagram below allows the calculation of permitted overhung load R_{x2} on the output shaft of gearbox type 315_VK, with radial force applying at a distance x from shaft shoulder.

The curves are relevant to value resulting from the relationship of trust load A_{n2} to radial load R_{n2} , based on $n_2 = 10 \text{ min}^{-1}$ and 10000 hrs theoretical lifetime.

Das nachstehende Diagramm ermöglicht das Individuieren der zulässigen, auf die Welle des Getriebes 315_VK einwirkenden Radialkraft, die auf der Distanz x vom Anschlag der Welle selbst appliziert wird.

Die Kurven beziehen sich auf den Wert, der sich aus dem Verhältnis zwischen der Axialkraft A_{n2} und der Radialkraft R_{n2} für $n_2 = 10 \text{ min}^{-1}$ und einer Dauer von 10000 Std. ergibt.

Le diagramme suivant permet de déterminer la charge radiale admissible R_{x2} sur l'arbre lent du réducteur 315_VK appliqué à la distance x de l'épaule de l'arbre.

Les courbes se réfèrent à la valeur résultant de l'équation entre la charge axiale A_{n2} et la charge radiale R_{n2} pour $n_2 = 10 \text{ min}^{-1}$ et durée de 10000 h.

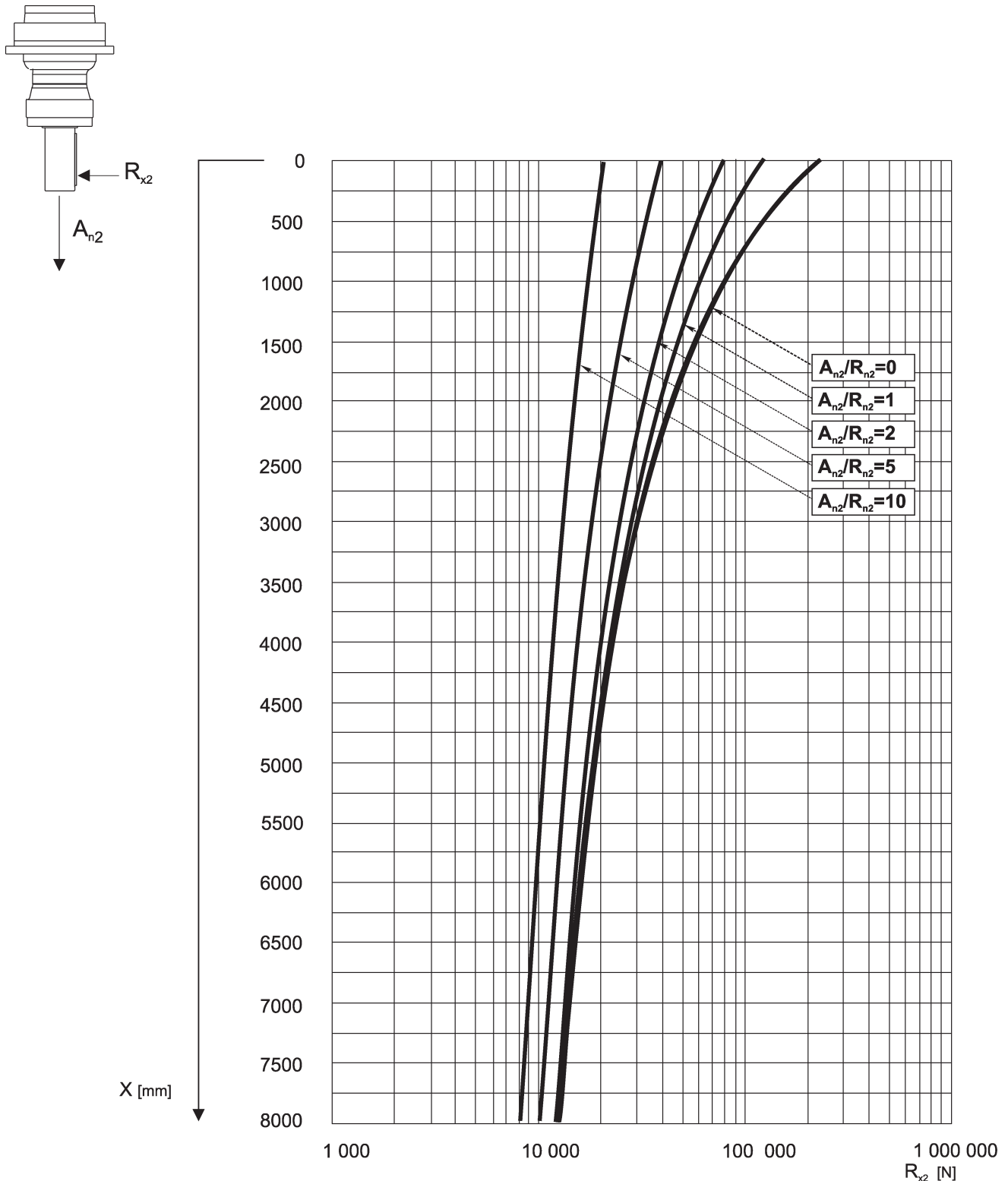

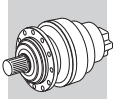

316 L

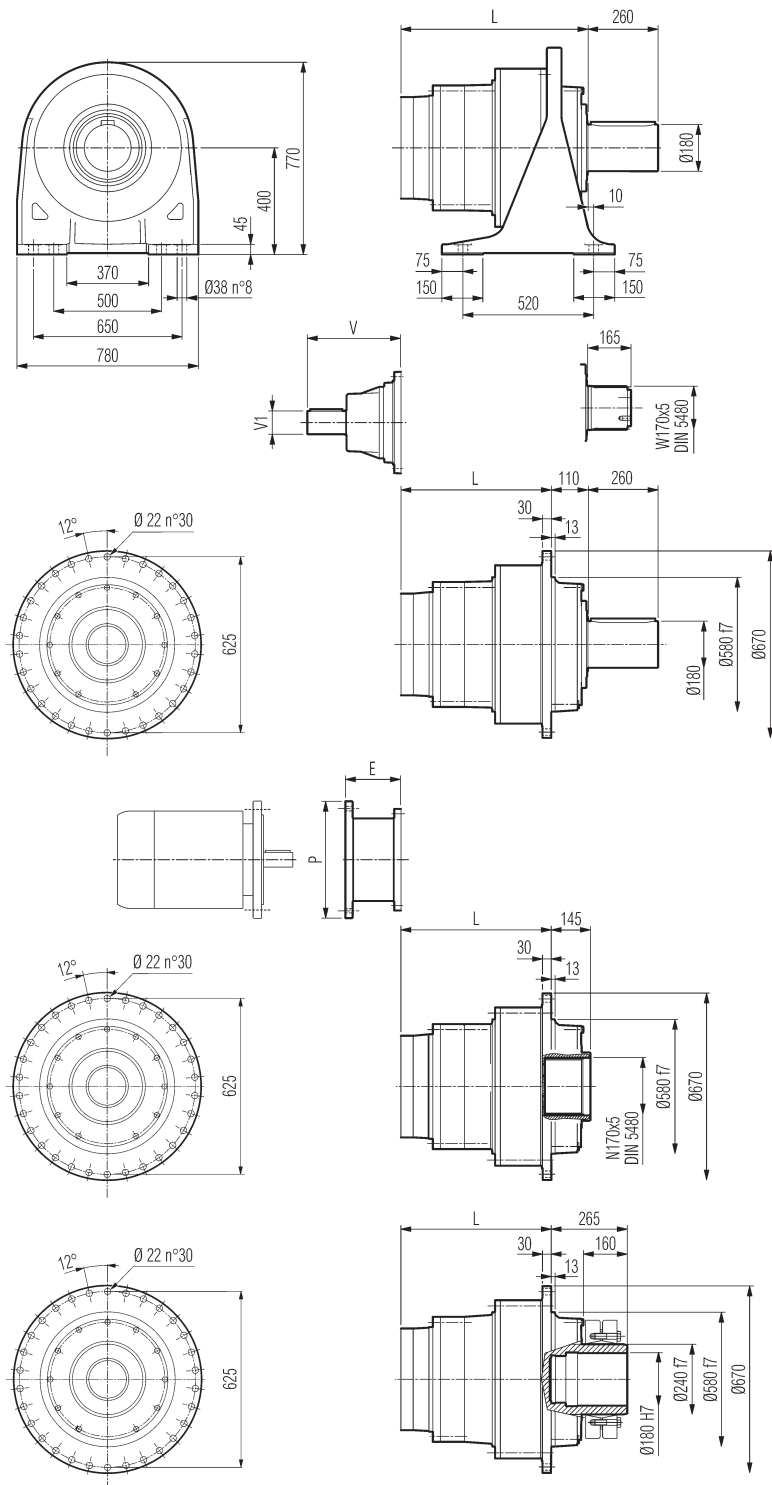

PC

HZ PZ

HC

FZ

FP

FP $M_{2max} = 162\ 000\ Nm$

	L				$\overset{\circ}{\text{Kg}}$				Albero veloce / Input shaft / Antriebswelle / Arbre d'entrée					
	PC - PZ	HC - HZ	FZ	FP	PC - PZ	HC - HZ	FZ	FP	V	V1	$\overset{\circ}{\text{Kg}}$	V	V1	$\overset{\circ}{\text{Kg}}$
316 L2	541	431	431	431	790	590	520	540	348	80	55	-	-	-
316 L3	674	564	564	564	840	640	570	590	315	80	35	313	60	28
316 L4	763	653	653	653	860	660	590	610	239	48	15	-	-	-

	P132		P160		P180		P200		P225	
	E	P	E	P	E	P	E	P	E	P
316 L2	-	-	-	-	-	-	-	-	-	-
316 L3	-	-	-	-	195	350	186	400	216	450
316 L4	114	300	144	350	144	350	-	-	-	-

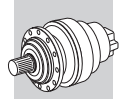

PC

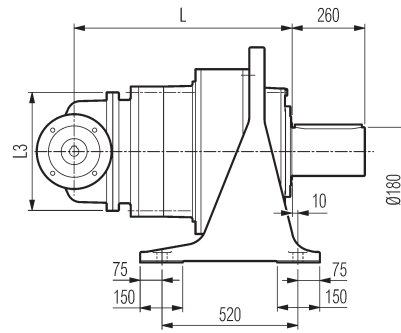
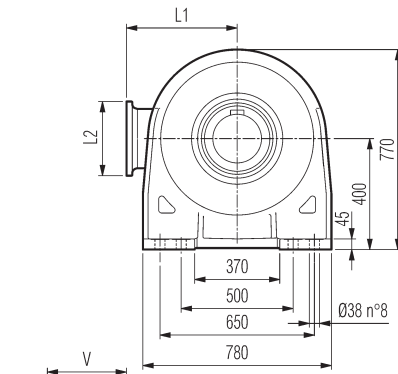

HZ PZ

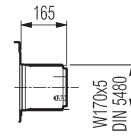
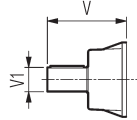

HC

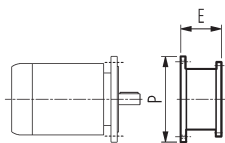
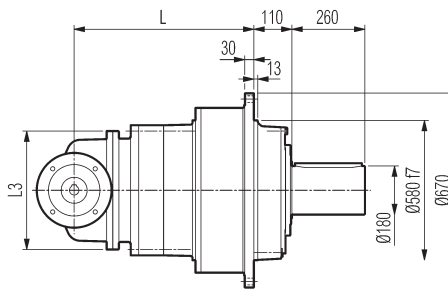
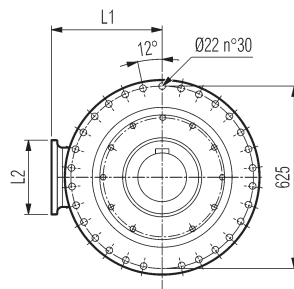

FZ

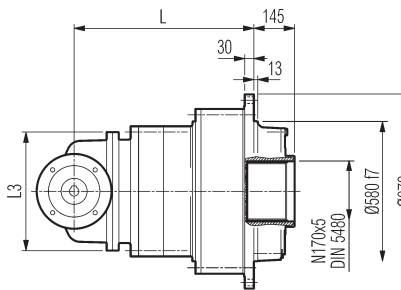
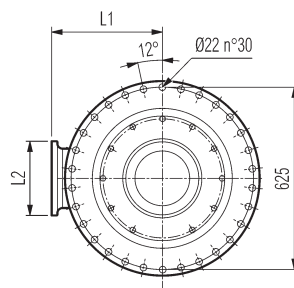

FP

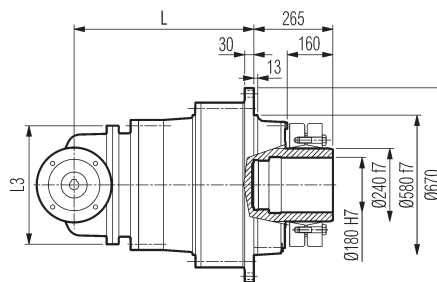
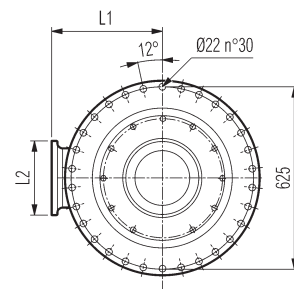

FP $M_{2max} = 162\,000\text{ Nm}$

	L				L1	L2	L3	Kg				Albero veloce / Input shaft Antriebswelle / Arbre d'entrée					
	PC - PZ	HC - HZ	FZ	FP				PC - PZ	HC - HZ	FZ	FP	V	V1	Kg	V	V1	Kg
316 R3 (B)	766	656	656	656	345	292	400	910	710	640	660	307	60	23	-	-	-
316 R3 (C)	766	656	656	656	390	292	480	920	720	650	670	307	60	23	-	-	-
316 R4	793	683	683	683	225	245	345	890	690	620	640	239	48	15	-	-	-

	P132		P160M		P180		P200L		P225		P250	
	E	P	E	P	E	P	E	P	E	P	E	P
316 R3 (B)	-	-	-	-	152	350	182	400	212	450	193	550
316 R3 (C)	-	-	-	-	152	350	182	400	212	450	193	550
316 R4	114	300	144	350	144	350	174	400	-	-	-	-

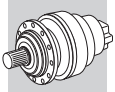

3/V 16L3

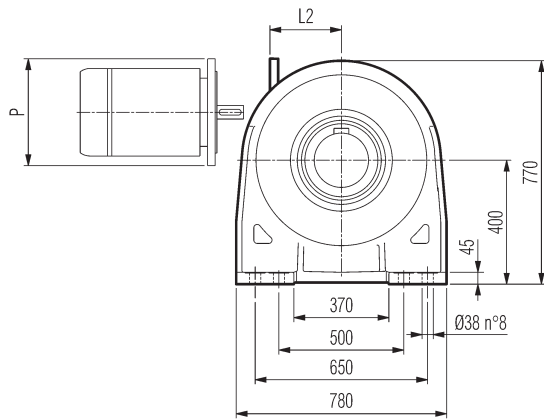

PC

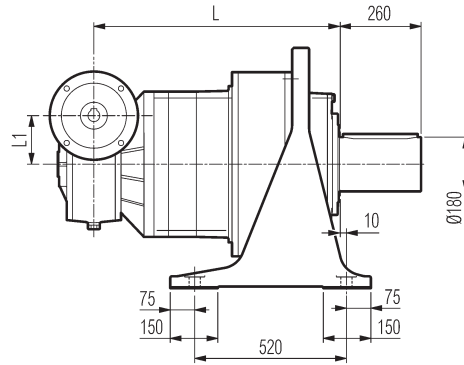

HZ PZ

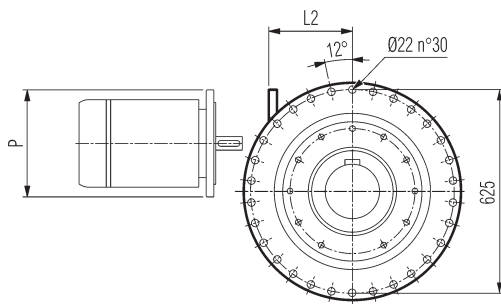
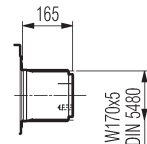

HC

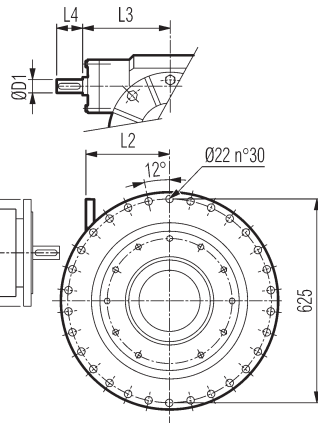
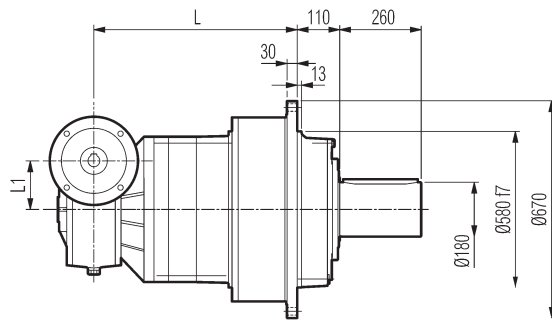

FZ

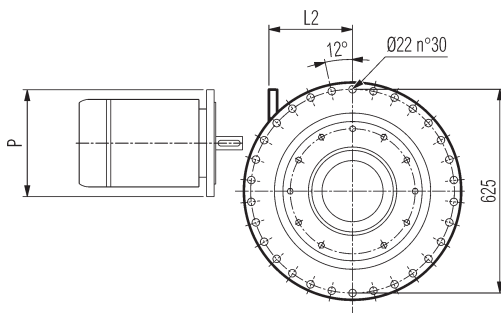
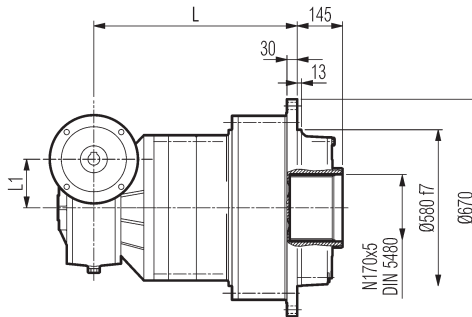

FP

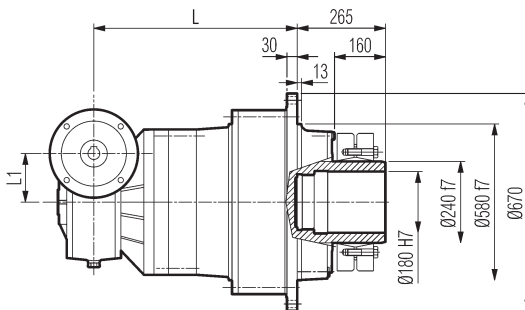

FP

M_{2max} = 162 000 Nm

	L				L1	D1	L3	L4	Kg			
	PC - PZ	HC - HZ	FZ	FP					PC - PZ	HC - HZ	FZ	FP
3/V 16L3	766	656	656	656	210	48	230	110	990	790	720	740
	P132		P160		P180		P200		P225			
	L2	P	L2	P	L2	P	L2	P	L2	P		
3/V 16L3	485	300	460	350	460	350	485	400	490	450		

3/V 16L4

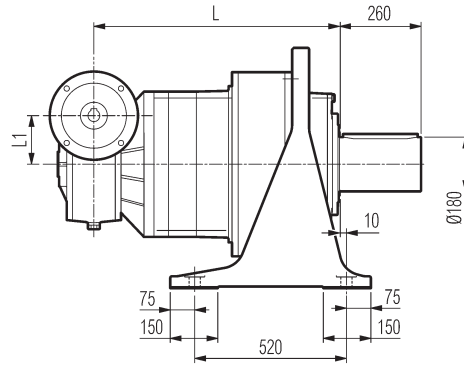
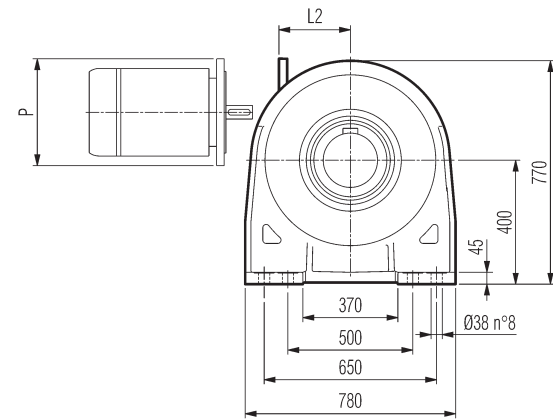
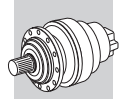

PC

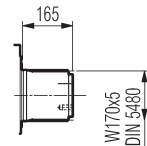

HZ PZ

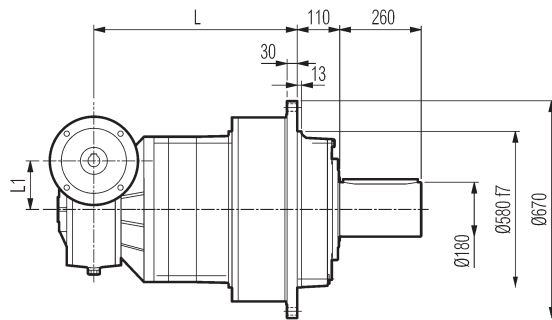
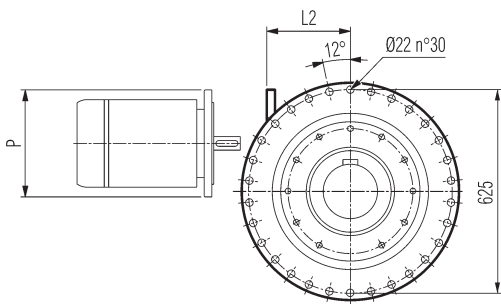

HC

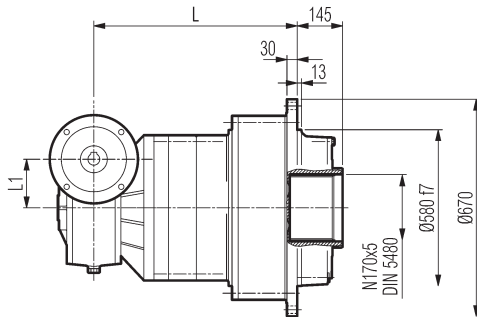
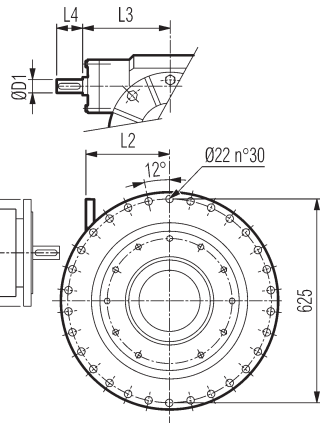

FZ

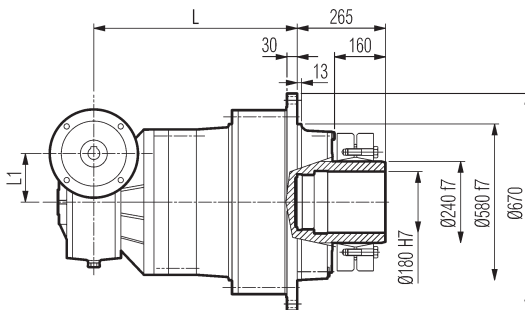
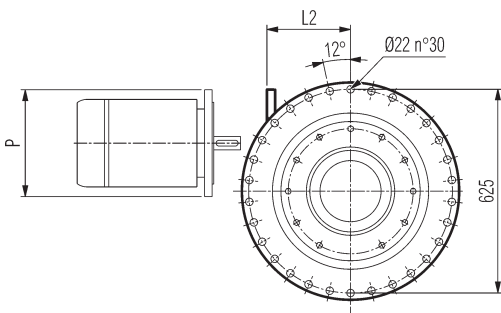

FP

FP $M_{2max} = 162\,000 \text{ Nm}$

	L				L1	D1	L3	L4	Kg			
	PC - PZ	HC - HZ	FZ	FP					PC - PZ	HC - HZ	FZ	FP
3/V 16L4	865	755	755	755	150	35	185	65	900	700	630	650
	P100		P112		P132		P160					
	L2	P	L2	P	L2	P	L2	P				
3/V 16L4	190	250	190	250	190	300	190	350				

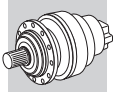

316 L

316 R

3/V 16L3

3/V 16L4

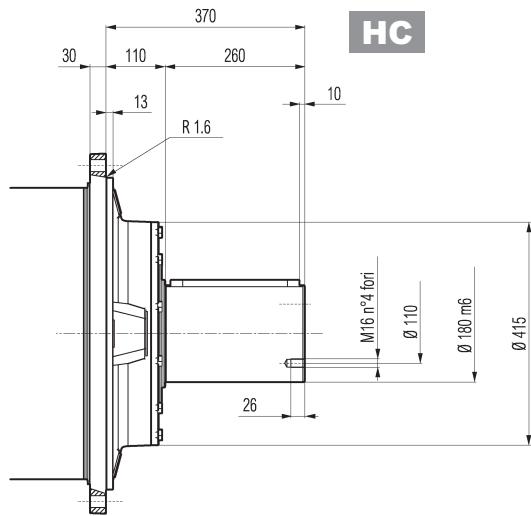

HC

A45x25x240
UNI 6604
DIN 6885

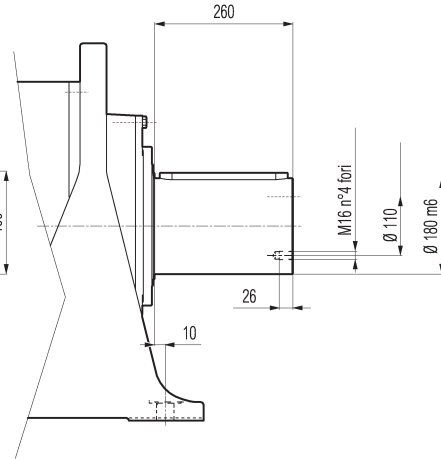
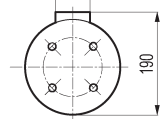

PC

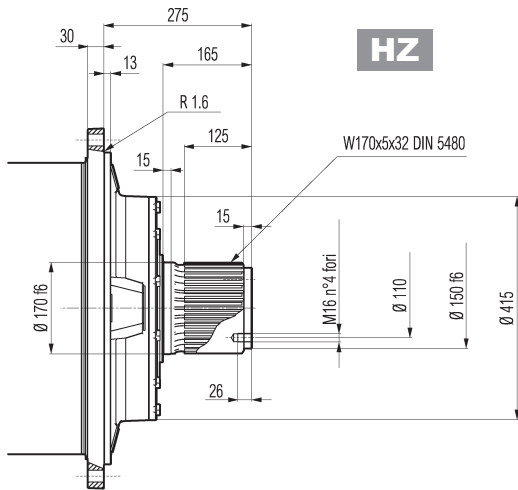

HZ

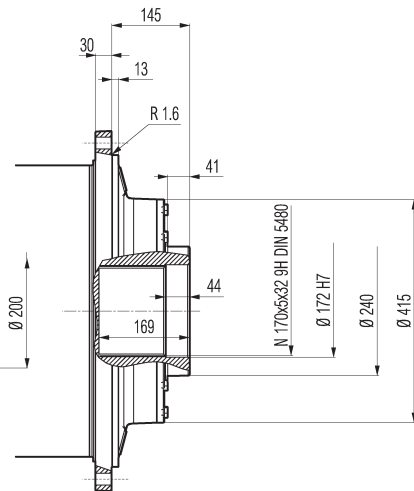
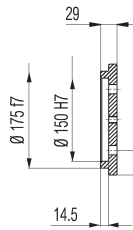

FZ

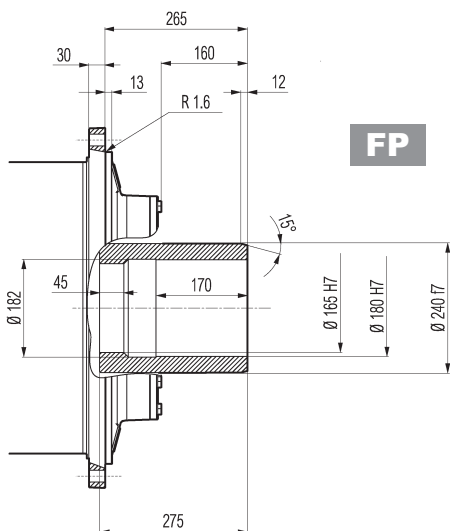

FP

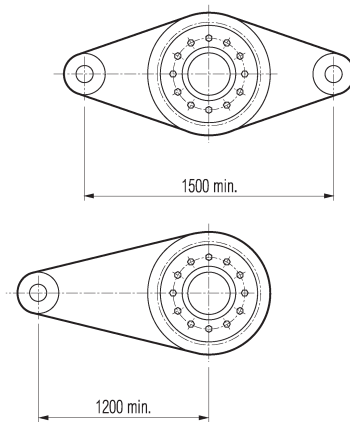
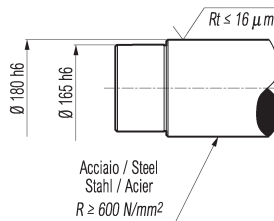

FP	M_{2max} = 162 000 Nm
-----------	--------------------------------------

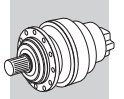
316 L**316 R****3/V 16L3****3/V 16L4**

Flangia / Flange
Flansch / Brides

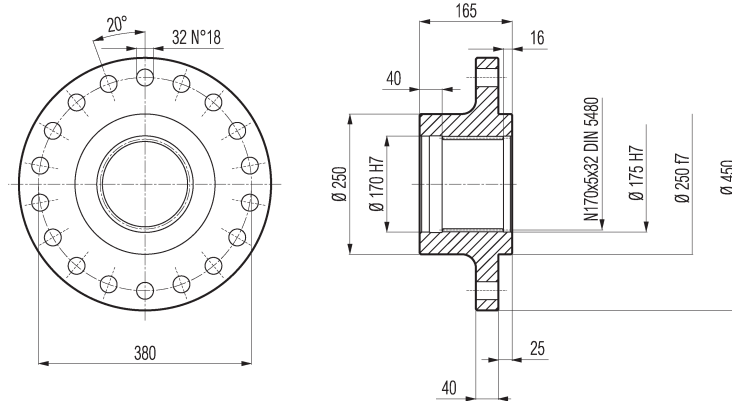
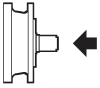
WOA

Materiale : Acciaio C40
 Material : Steel C40
 Material : Stahl C40
 Matière : Acier C40

Manicotti lisci / Sleeve couplings
Naben / Manchons lisses a cannelure interieure

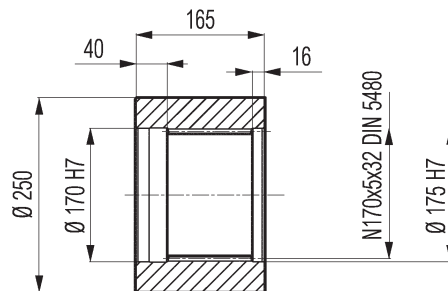
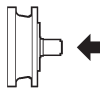
MOA

Materiale : Acciaio C40
 Material : Steel C40
 Material : Stahl C40
 Matière : Acier C40

Giunto ad attrito / Shrink disc
Schrumpfscheibe / Frette de serrage

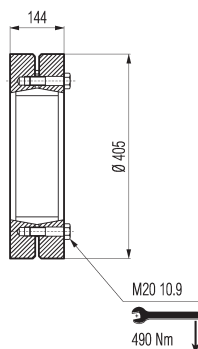
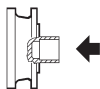
GOA

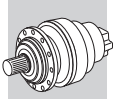

316 L

316 R

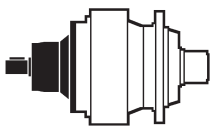
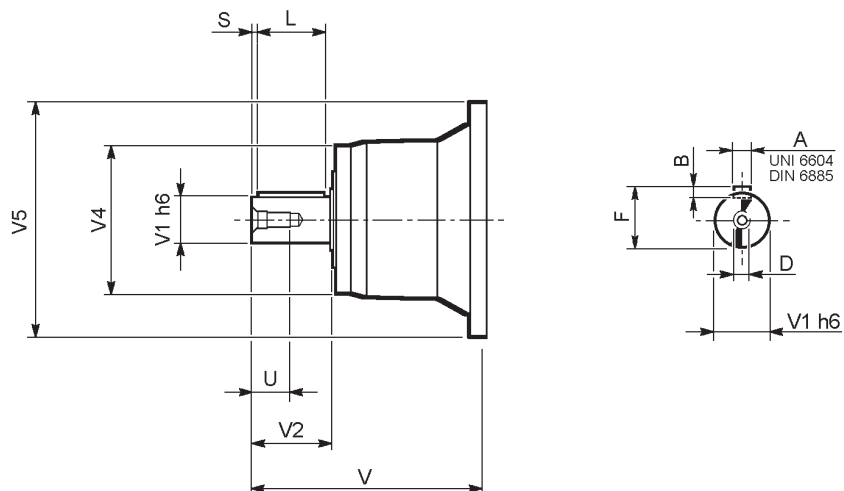

	CODE	V	V1	V2	V4	V5	A	B	F	L	S	D	U
316 L2	V11B	348	80	130	200	418	22	14	85	110	10	M16	36
316 L3	V07B	315	80	130	200	345	22	14	85	110	10	M16	36
	V07A	313	60	105	155	345	18	11	64	90	7.5	M16	36
316 L4	V05B	239	48	82	155	245	14	9	51.5	70	6	M16	36
316 R4	V05B	239	48	82	155	245	14	9	51.5	70	6	M16	36
316 R3 (B) (C)	V06B	307	60	105	155	292	18	11	64	90	7.5	M16	36

3/V 16L3

3/V 16L4

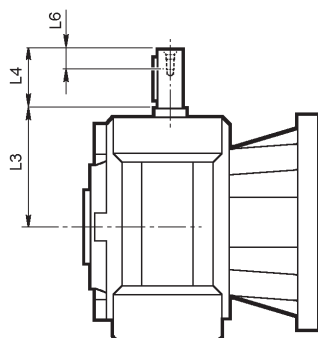
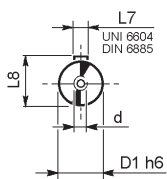

	D1 h6	L3	L4	L6	L7	L8	d
3/V 16L3 HS	48	230	110	40	14	51.5	M16
3/V 16L4 HS	35	185	65	20	10	38	M8

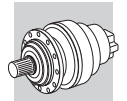

Fattore di posizione per carichi radiali sugli alberi in uscita.

Load location factor for radial loading on output shaft.

Positionsfaktor für Radialkräfte an der Abtriebswelle.

Facteur de position pour charges radiales sur les arbres en sortie.

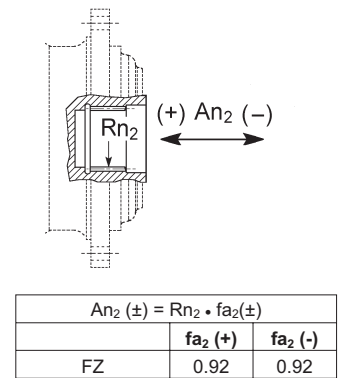
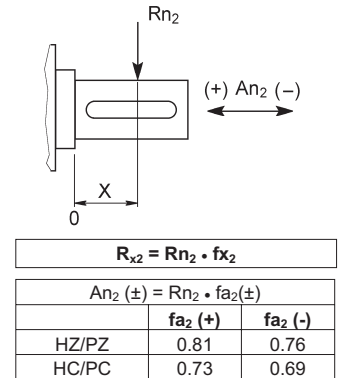
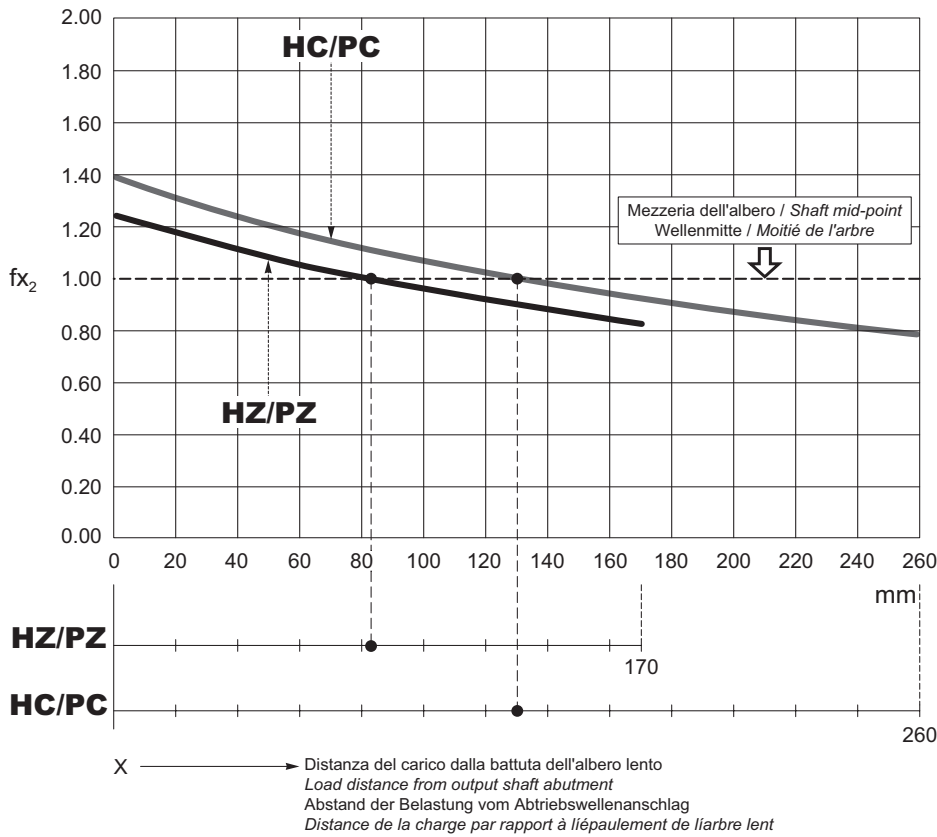

Carichi radiali ammissibili sull'albero veloce per $n_1 = 1000 \text{ min}^{-1}$ e 10000 h di vita teorica. Per velocità di comando e/o durate diverse vedi il capitolo: Verifiche.

Permitted overhung loads on input shaft when $n_1 = 1000 \text{ min}^{-1}$ and theoretical lifetime = 10000 h. For drive speed and/or lifetimes other than those specified here, see Chapter: Verifications.

Zulässige Radialkräfte an den Antriebswellen für $n_1 = 1000 \text{ min}^{-1}$ und 10000 std. Im Hinblick auf Geschwindigkeit und/oder anderweitige Dauern verweisen wir auf Par: Prüfungen

Charges radiales admissibles sur les arbres d'entrée pour $n_1 = 1000 \text{ min}^{-1}$ et 10000 h. Pour des vitesses et/ou durées différentes, voir par. Vérifications.

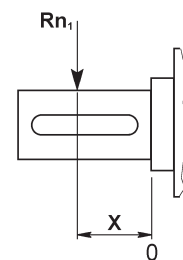
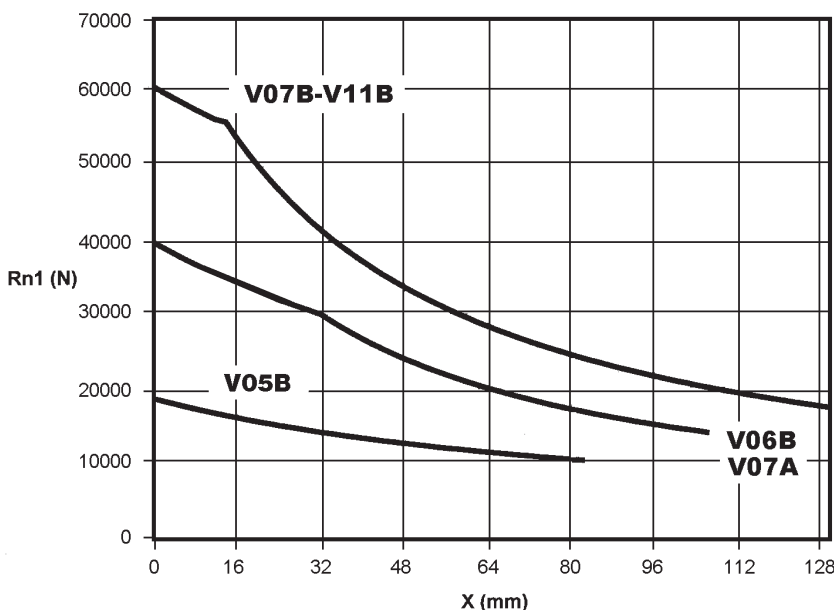

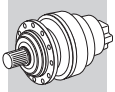

317 L

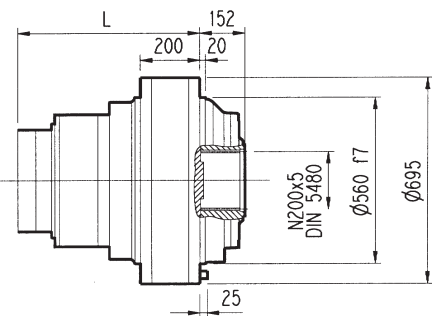
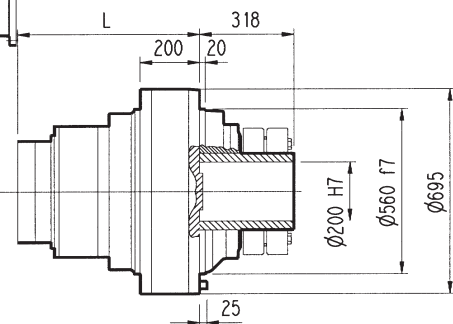
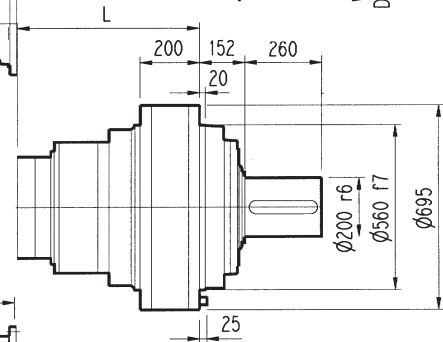
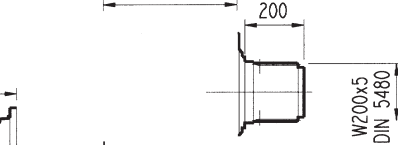
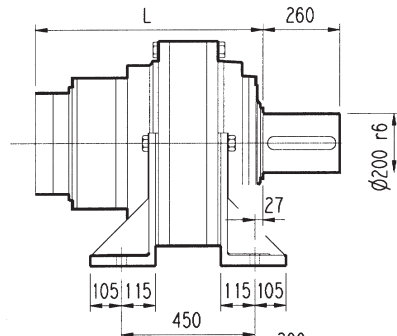
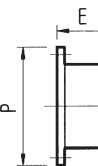
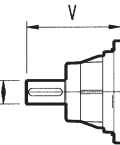
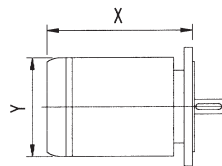
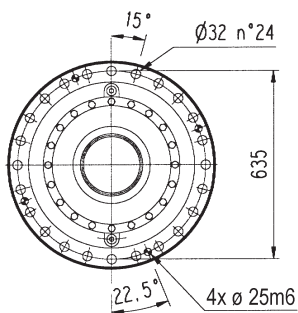
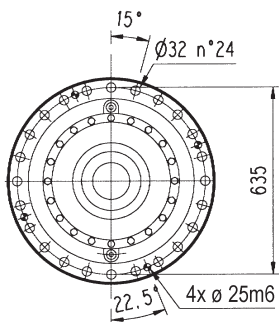
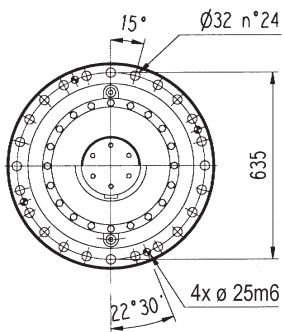
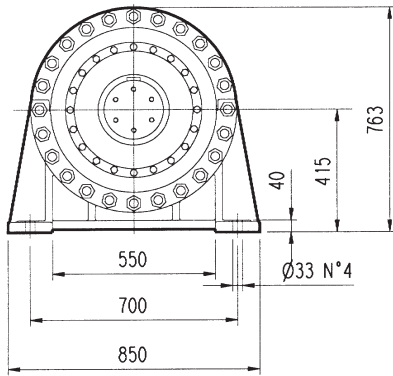

PC

HZ PZ

HC

FP

FZ

FP

M_{2max} = 216 000 Nm

	L				Kg				Albero veloce / Input shaft Antriebswelle / Arbre d'entrée					
	PC - PZ	HC - HZ	FZ	FP	PC - PZ	HC - HZ	FZ	FP	V	V1	Kg	V	V1	Kg
317 L2	624	475	475	475	1080	930	880	930	343	80	55	-	-	-
317 L3	774	622	622	622	1140	990	940	990	315	80	35	313	60	28
317 L4	862	710	710	710	1152	1000	952	1000	239	48	15	-	-	-

	P132		P160		P180		P200		P225		P250M	
	E	P	E	P	E	P	E	P	E	P	E	P
317 L2	-	-	-	-	-	-	-	-	-	-	-	-
317 L3	-	-	-	-	196	350	186	400	216	450	216	550
317 L4	114	300	144	350	144	350	-	-	-	-	-	-

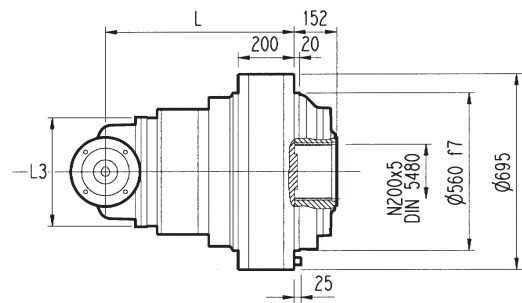
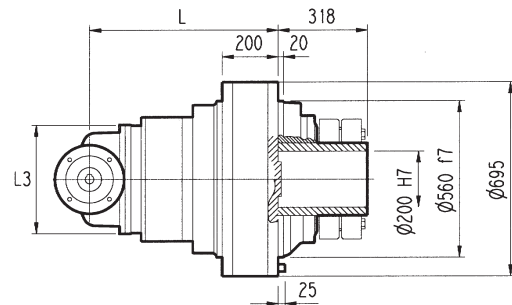
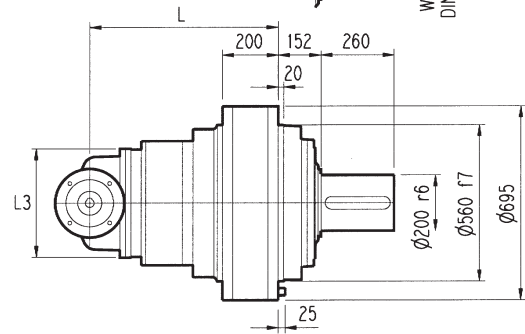
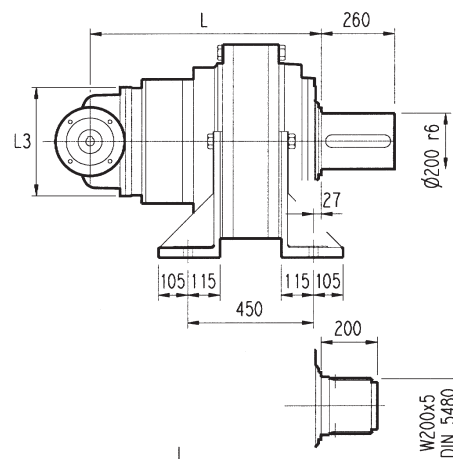
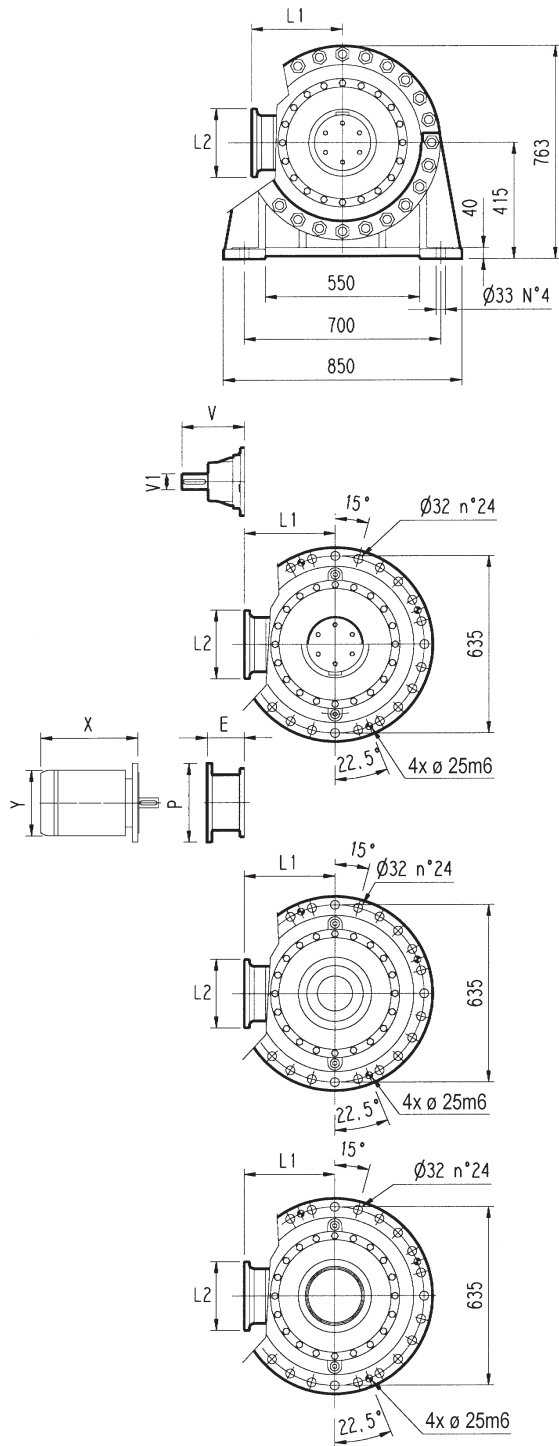
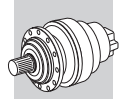

PC

HZ PZ

HC

FP

FZ

FP

M_{2max} = 216 000 Nm

	L				L1	L2	L3	Kg				Albero veloce / Input shaft Antriebswelle / Arbre d'entrée					
	PC - PZ	HC - HZ	FZ	FP				PC - PZ	HC - HZ	FZ	FP	V	V1	Kg	V	V1	Kg
317 R3 (B)	853	701	701	701	345	292	400	1210	1060	1010	1060	307	60	23	-	-	-
317 R3 (C)	853	701	701	701	390	292	480	1220	1070	1020	1070	307	60	23	-	-	-
317 R3 (A)	853	701	701	701	330	245	390	1190	1040	990	1040	239	48	15	-	-	-
317 R4	892	740	740	740	225	245	345	1190	1040	990	1040	239	48	15	-	-	-

	P132		P160M		P180		P200L		P225		P250	
	E	P	E	P	E	P	E	P	E	P	E	P
317 R3 (B)	-	-	-	-	152	350	182	400	212	450	193	550
317 R3 (C)	-	-	-	-	152	350	182	400	212	450	193	550
317 R3 (A)	114	300	144	350	144	350	174	400	-	-	-	-
317 R4	114	300	144	350	144	350	174	400	-	-	-	-

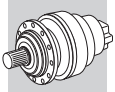

3/V 17L3

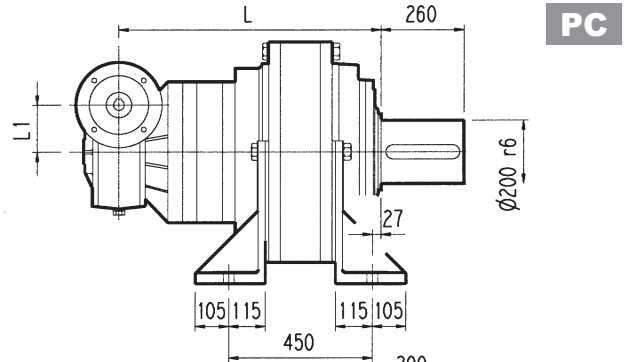
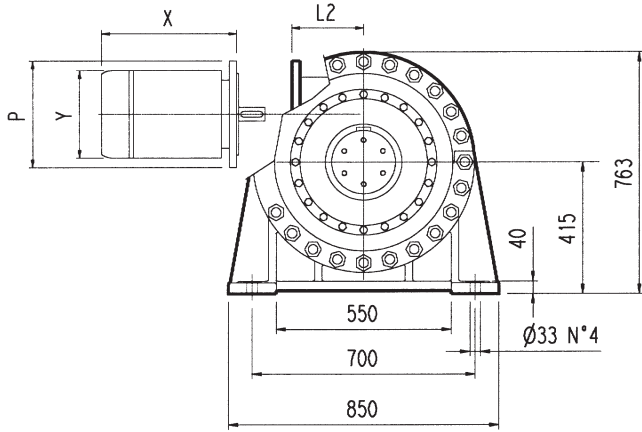

PC

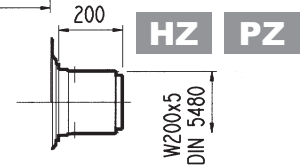

HZ PZ

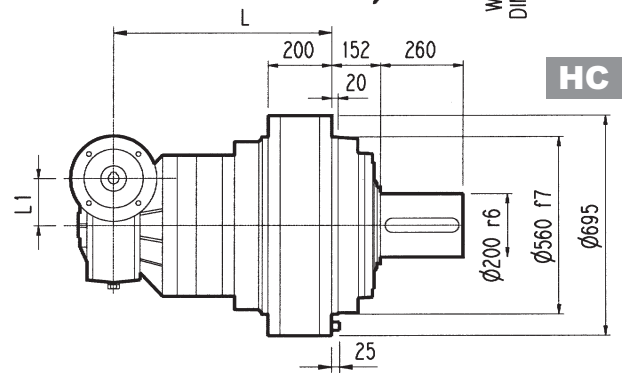
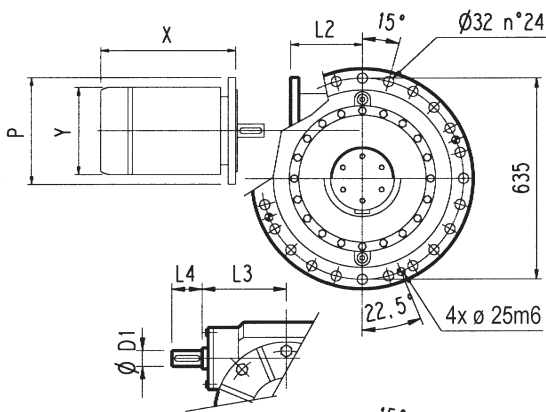

HC

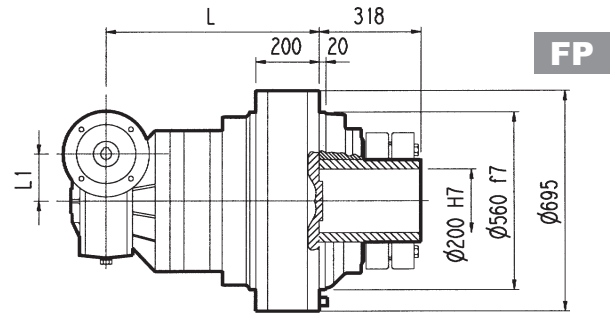
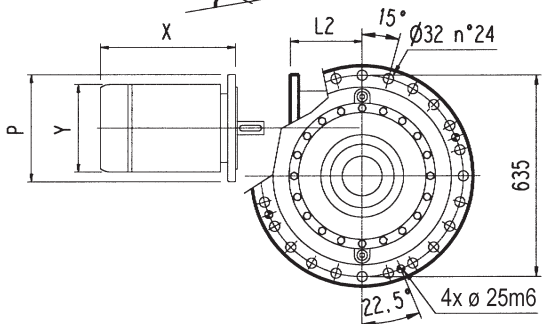

FP

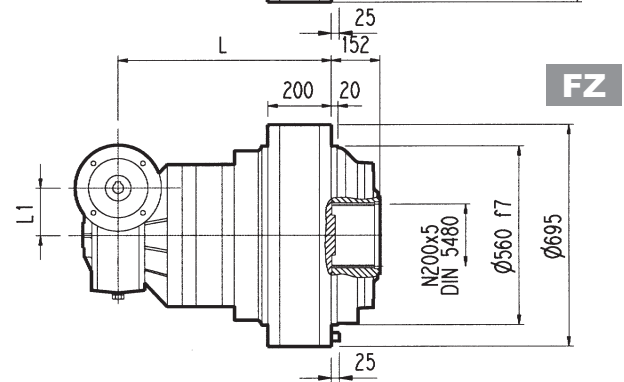
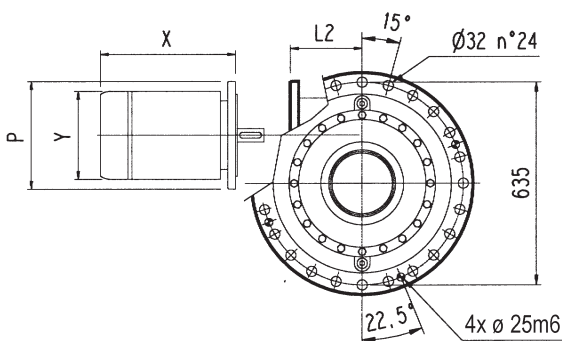

FZ

FP $M_{2max} = 216\,000 \text{ Nm}$

	L				L1	D1	L3	L4	Kg			
	PC - PZ	HC - HZ	FZ	FP					PC - PZ	HC - HZ	FZ	FP
3/V 17L3	894	745	745	745	250	55	276	110	1400	1250	1200	1250

	P132		P160		P180		P200		P225	
	L2	P	L2	P	L2	P	L2	P	L2	P
3/V 17L3	531	300	506	350	506	350	531	400	536	450

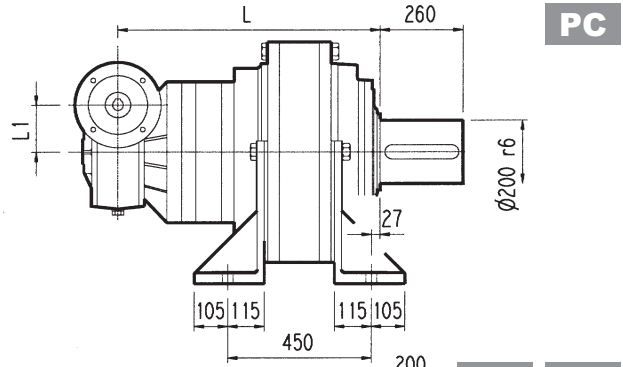
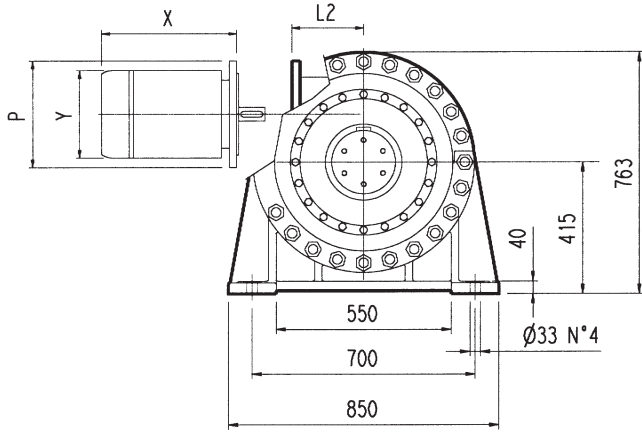
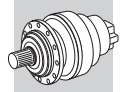

PC

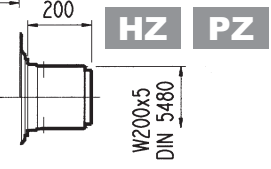

HZ PZ

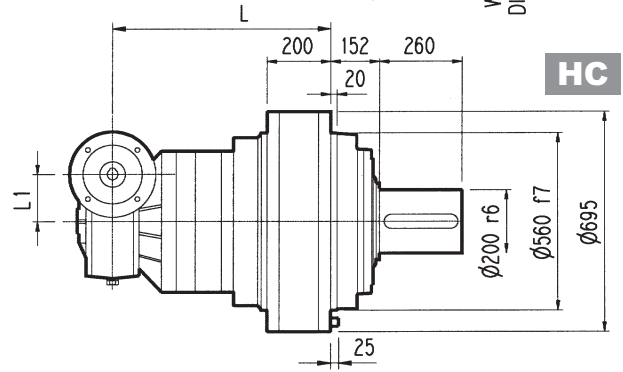
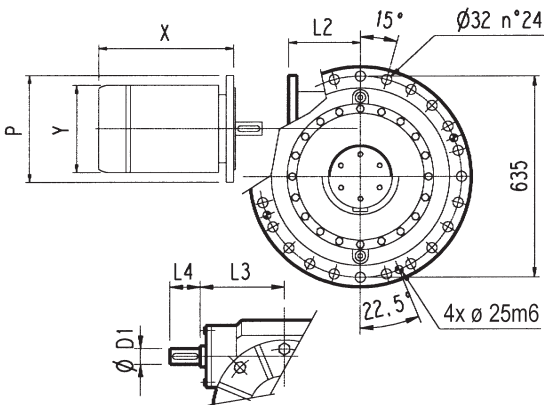

HC

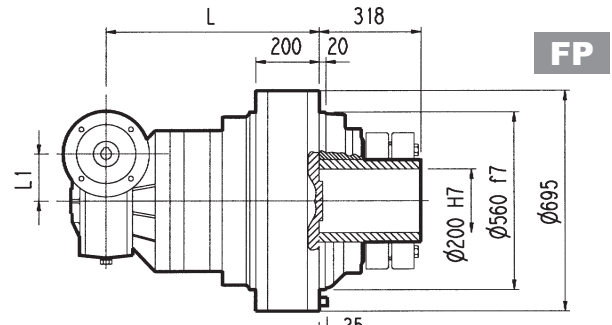
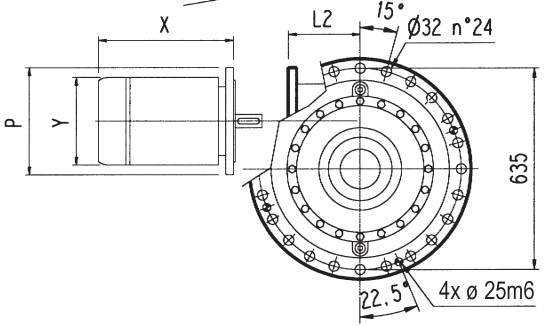

FP

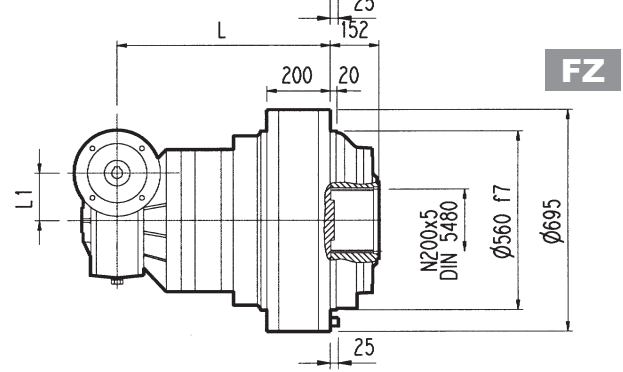
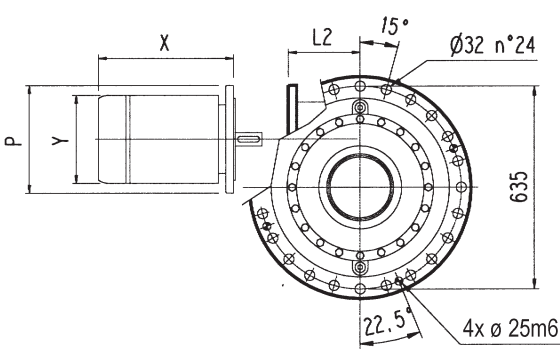

FZ

FP $M_{2max} = 216\ 000\ Nm$

	L				L1	D1	L3	L4	Kg			
	PC - PZ	HC - HZ	FZ	FP					PC - PZ	HC - HZ	FZ	FP
3/V 17L4	975	823	823	823	185.4	40	214.5	70	1250	1090	1040	1090

	P100		P112		P132		P160		P180	
	P	P	L2	P	L2	P	L2	P	L2	P
3/V 17L4	250	250	217	300	217	350	217	350	217	350

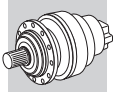
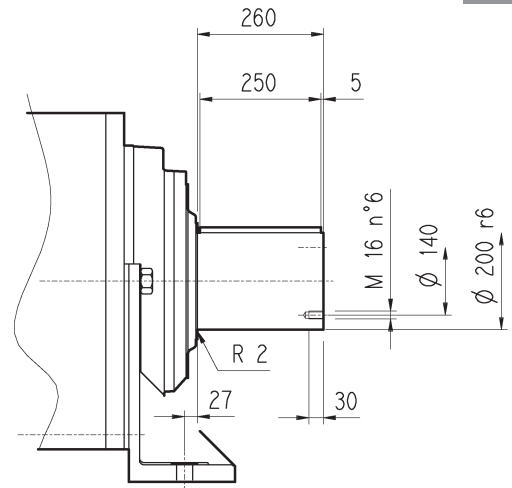
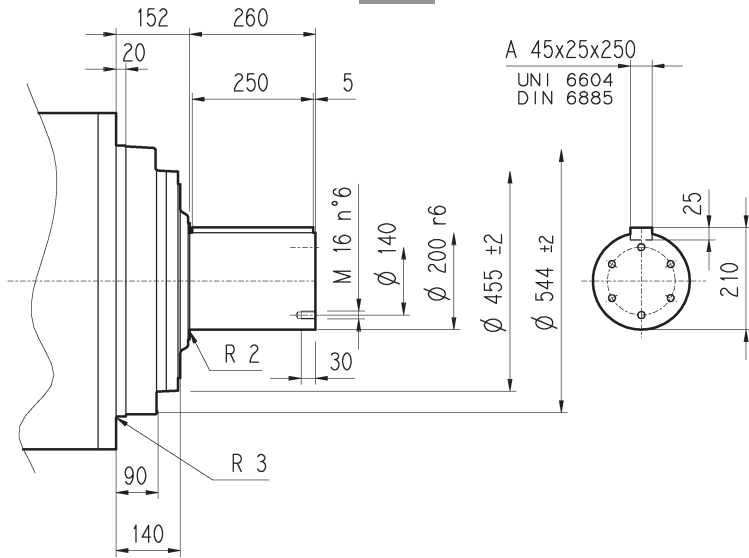
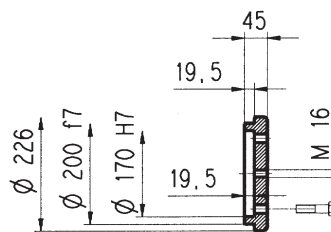
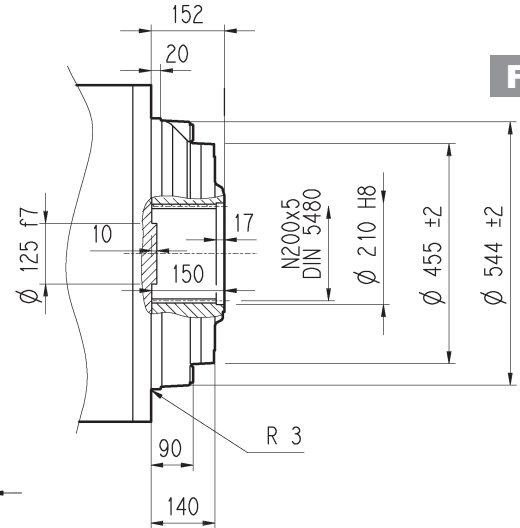
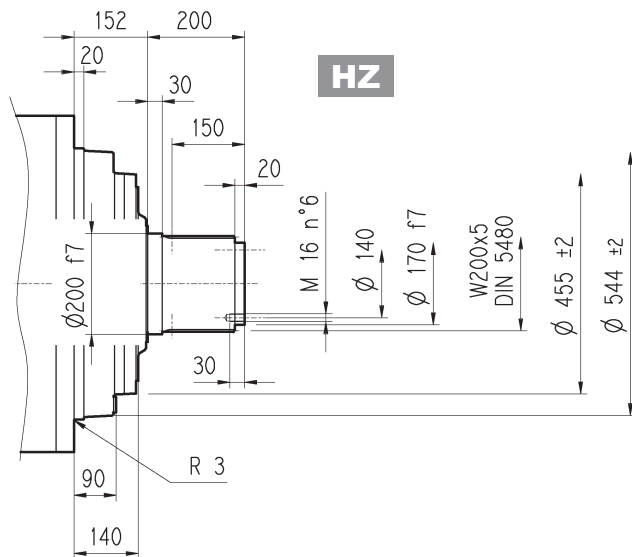
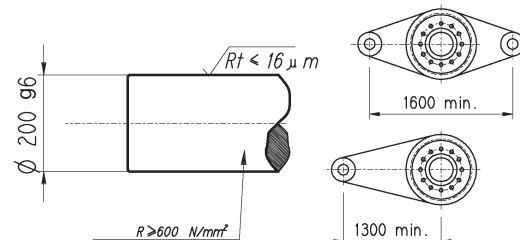
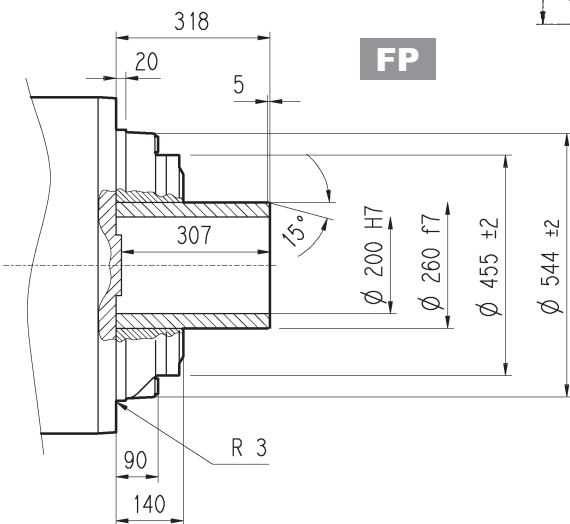
**317 L****317 R****3/V 17L3****3/V 17L4****HC****PC****HZ****FZ****FP****FP****M_{2max} = 216 000 Nm**

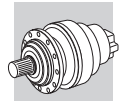
317 L**317 R****3/V 17L3****3/V 17L4**

Flangia / Flange
Flansch / Brides

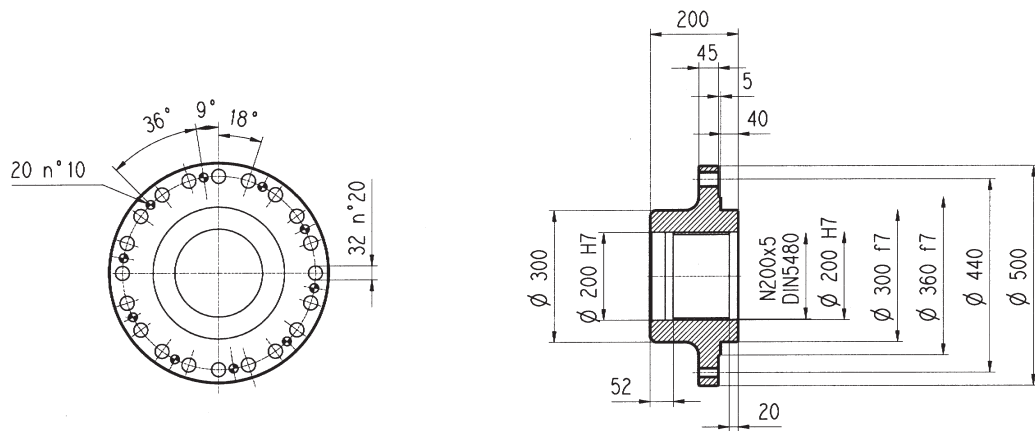
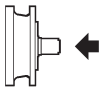
WOA

Materiale : Acciaio C40
Material : Steel C40
Material : Stahl C40
Màterial : Acier C40

Manicotti lisci / Sleeve couplings
Naben / Manchons lisses a cannelure interieure

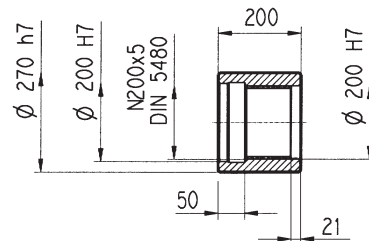
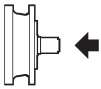
MOA

Materiale : Acciaio 16CrNi4
Material : Steel 16CrNi4
Material : Stahl 16CrNi4
Màterial : Acier 16CrNi4

Giunto ad attrito / Shrink disc
Schrumpfscheibe / Frette de serrage

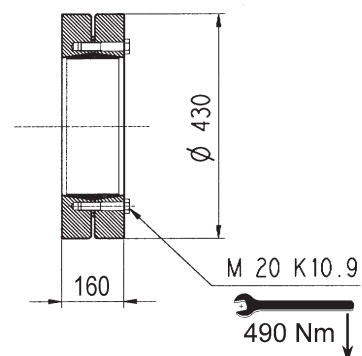
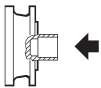
GOA

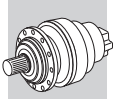

317 L

317 R

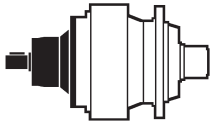
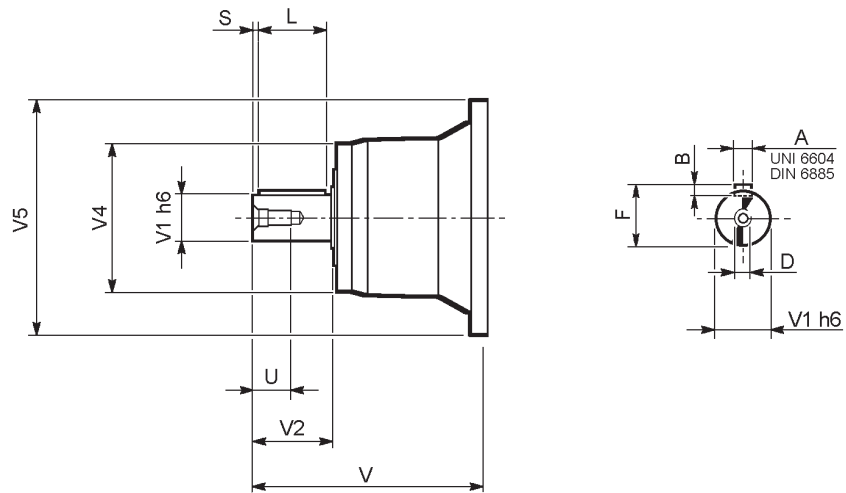

	CODE	V	V1	V2	V4	V5	A	B	F	L	S	D	U
317 L2	V11B	343	80	130	200	445	22	14	85	110	10	M16	36
317 L3	V07B	315	80	130	200	345	22	14	85	110	10	M16	36
	V07A	313	60	105	155	345	18	11	64	90	7.5	M16	36
317 L4	V05B	239	48	82	155	245	14	9	51.5	70	6	M16	36
317 R3 (A) - R4	V05B	239	48	82	155	245	14	9	51.5	70	6	M16	36
317 R3 (B) (C)	V06B	307	60	105	155	292	18	11	64	90	7.5	M16	40

3/V 17L3

3/V 17L4

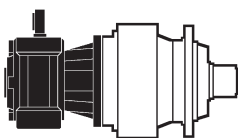
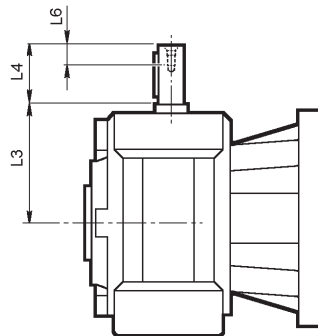
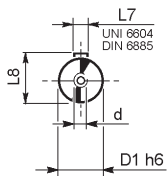

	D1 h6	L3	L4	L6	L7	L8	d
3/V 17L3_HS	55	276	110	40	16	59	M16
3/V 17L4_HS	40	214.5	70	20	12	43	M8

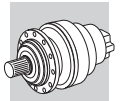

Fattore di posizione per carichi radiali sugli alberi in uscita.

Load location factor for radial loading on output shaft.

Positionsfaktor für Radialkräfte an der Abtriebswelle.

Facteur de position pour charges radiales sur les arbres en sortie.

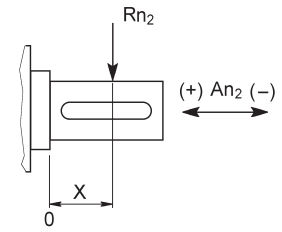
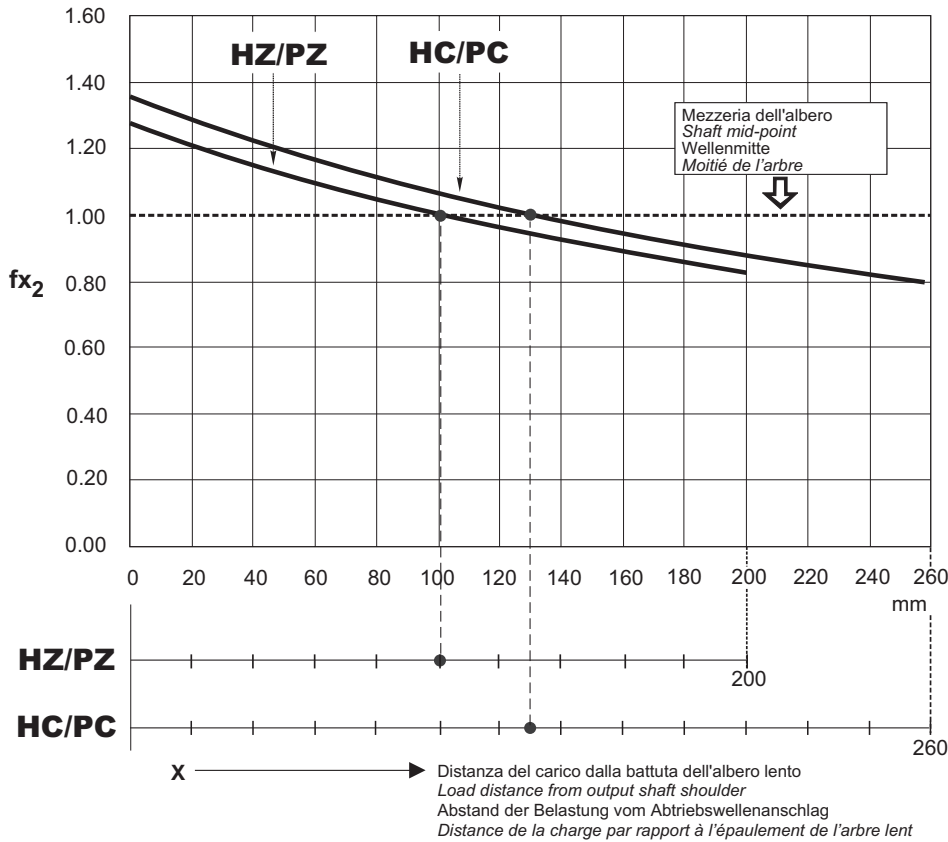

$$R_{x2} = R_{n2} \cdot f_{x2}$$

$An_2 (\pm) = R_{n2} \cdot fa_2 (\pm)$		
	$fa_2 (+)$	$fa_2 (-)$
HZ/PZ	0.77	0.64
HC/PC	0.81	0.68

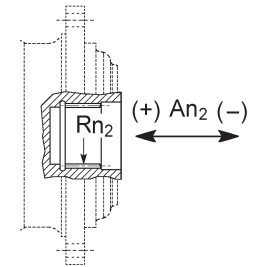

$An_2 (\pm) = R_{n2} \cdot fa_2 (\pm)$		
	$fa_2 (+)$	$fa_2 (-)$
FZ	1.00	1.00

Carichi radiali ammissibili sull'albero veloce per $n_1 = 1000 \text{ min}^{-1}$ e 10000 h di vita teorica. Per velocità di comando e/o durate diverse vedi il capitolo: Verifiche.

Permitted overhung loads on input shaft when $n_1 = 1000 \text{ min}^{-1}$ and theoretical lifetime = 10000 h. For drive speed and/or lifetimes other than those specified here, see Chapter: Verifications.

Zulässige Radialkräfte an den Antriebswellen für $n_1 = 1000 \text{ min}^{-1}$ und 10000 std. Im Hinblick auf Geschwindigkeit und/oder anderweitige Dauern verweisen wir auf Par: Prüfungen

Charges radiales admissibles sur les arbres d'entrée pour $n_1 = 1000 \text{ min}^{-1}$ et 10000 h. Pour des vitesses et/ou durées différentes, voir par. Vérifications.

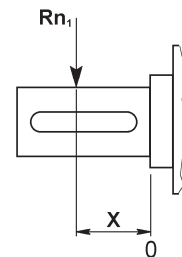
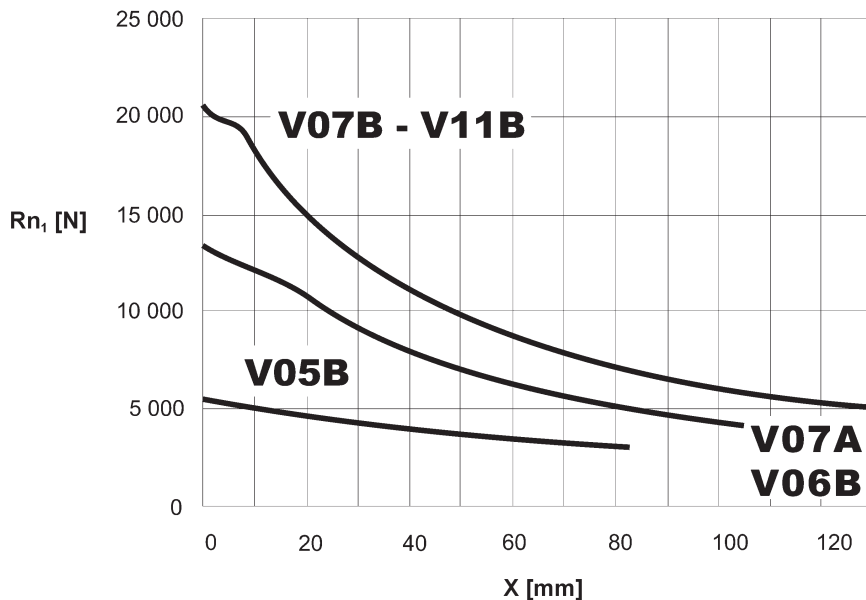

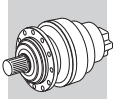

318 L

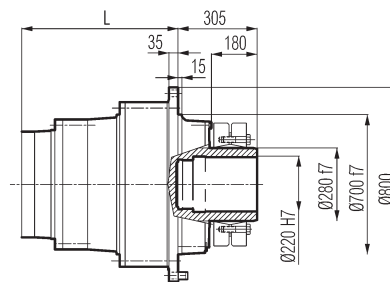
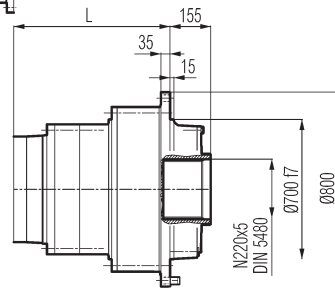
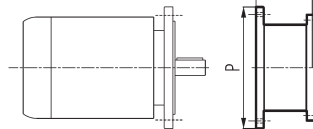
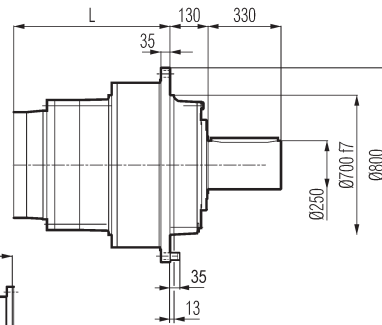
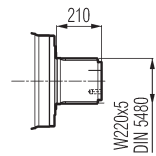
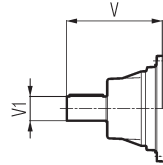
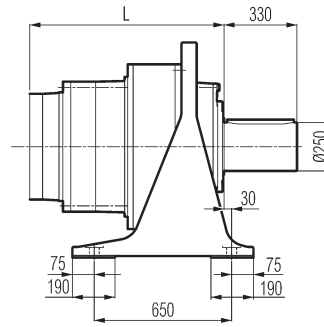
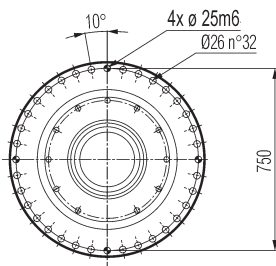
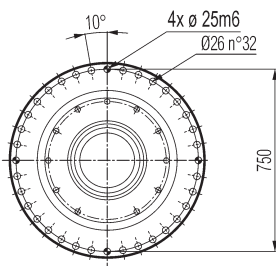
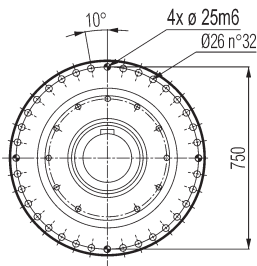
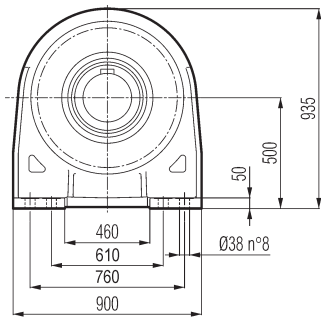

PC

HZ PZ

HC

FZ

FP

FP

$M_{2max} = 300\,000 \text{ Nm}$

	L				Kg				Albero veloce / Input shaft / Antriebswelle / Arbre d'entrée					
	PC - PZ	HC - HZ	FZ	FP	PC - PZ	HC - HZ	FZ	FP	V	V1	Kg	V	V1	Kg
318 L2	677	547	547	547	1500	1200	1050	1080	-	-	-	-	-	-
318 L3	889	759	759	759	1600	1300	1150	1180	348	80	55	-	-	-
318 L4	970	840	840	840	1650	1350	1200	1230	315	80	35	313	60	28

	P180		P200		P225	
	E	P	E	P	E	P
318 L2	-	-	-	-	-	-
318 L3	-	-	-	-	-	-
318 L4	195	350	186	400	216	450

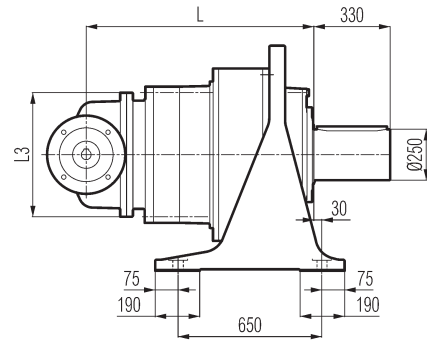
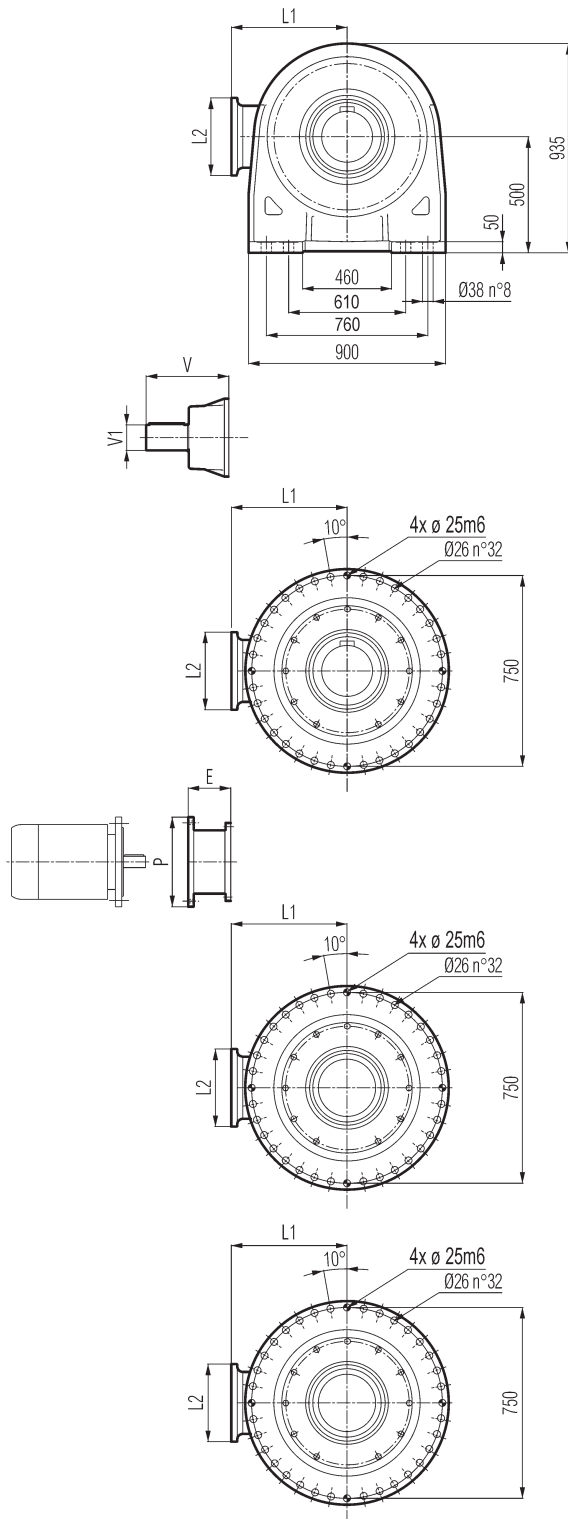
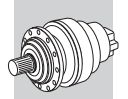

PC

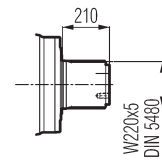

HZ PZ

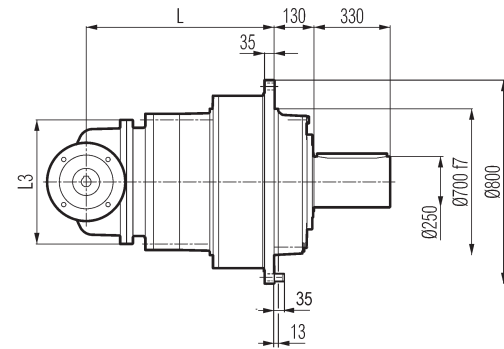

HC

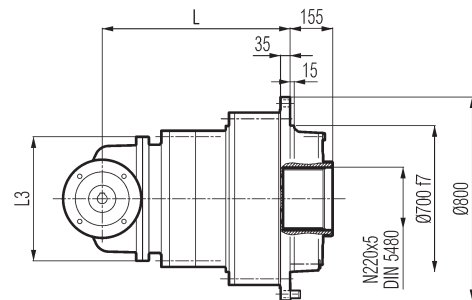

FZ

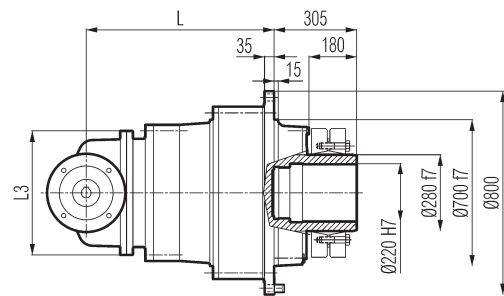

FP

FP

$M_{2max} = 300\,000 \text{ Nm}$

	L				L1	L2	L3	Kg				Albero veloce / Input shaft Antriebswelle / Arbre d'entrée					
	PC - PZ	HC - HZ	FZ	FP				PC - PZ	HC - HZ	FZ	FP	V	V1	Kg	V	V1	Kg
318 R4 (B)	1115	985	985	985	345	292	400	1720	1420	1270	1300	307	60	23	-	-	-
318 R4 (C)	1115	985	985	985	390	292	480	1730	1430	1280	1310	307	60	23	-	-	-
	P132		P160M		P180		P200L		P225		P250						
	E	P	E	P	E	P	E	P	E	P	E	P					
318 R4 (B)	-	-	-	-	152	350	182	400	212	450	193	550					
318 R4 (C)	-	-	-	-	152	350	182	400	212	450	193	550					

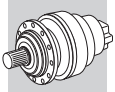

3/V 18L4

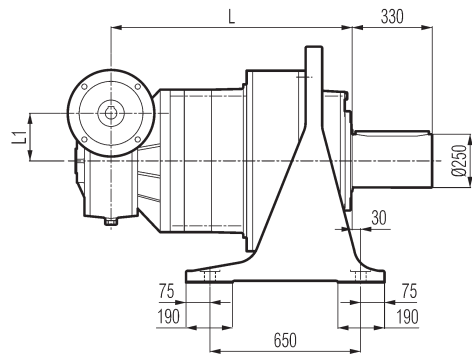
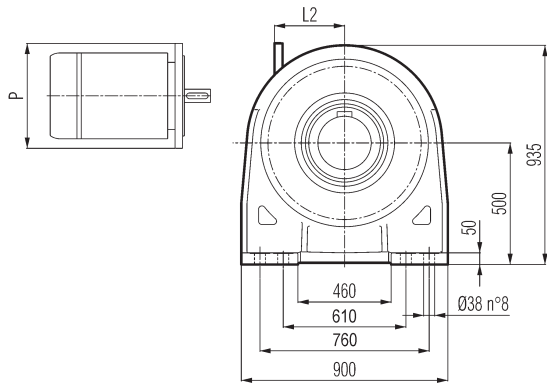

PC

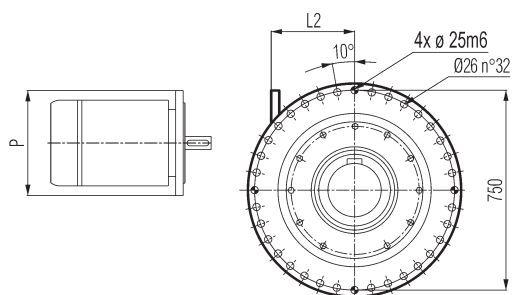

HZ PZ

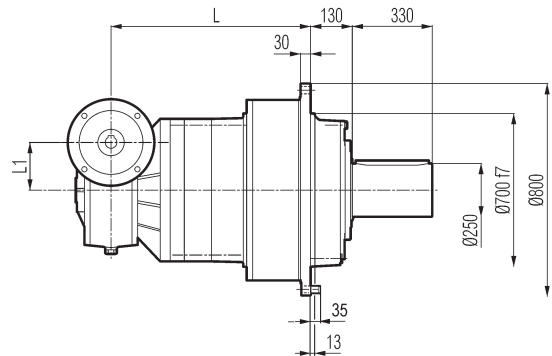
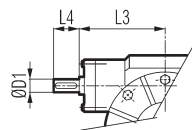

HC

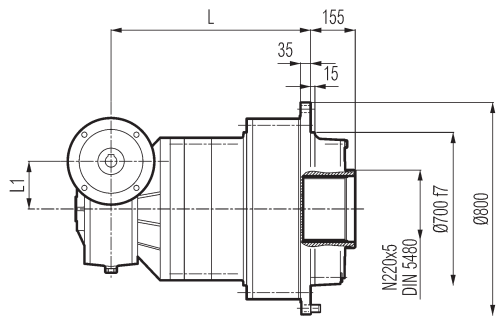
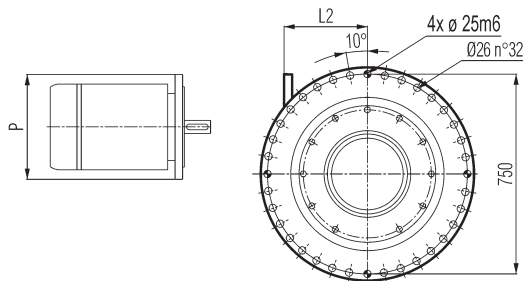

FZ

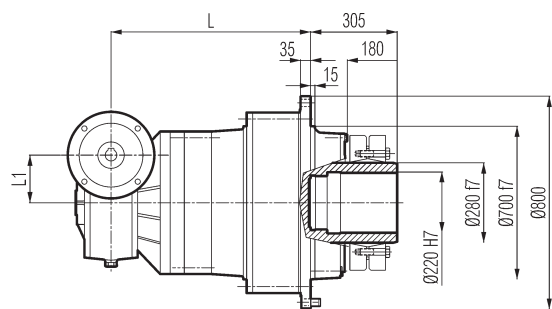
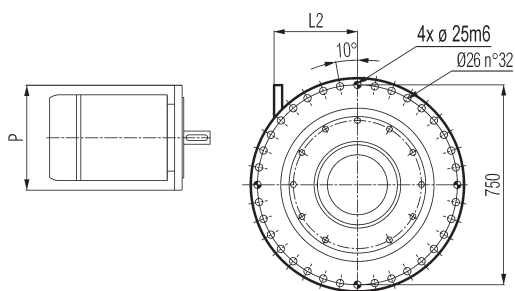

FP

FP

$M_{2max} = 300\,000 \text{ Nm}$

	L				L1	D1	L3	L4	Kg			
	PC - PZ	HC - HZ	FZ	FP					PC - PZ	HC - HZ	FZ	FP
3/V 18L4	1114	984	984	984	210	48	230	110	1810	1510	1360	1390

	P132		P160		P180		P200		P225	
	L2	P	L2	P	L2	P	L2	P	L2	P
3/V 18L4	485	300	460	350	460	350	485	400	490	450

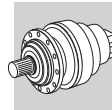

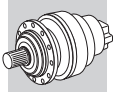

318 L

318 R

3/V 18L4

HC

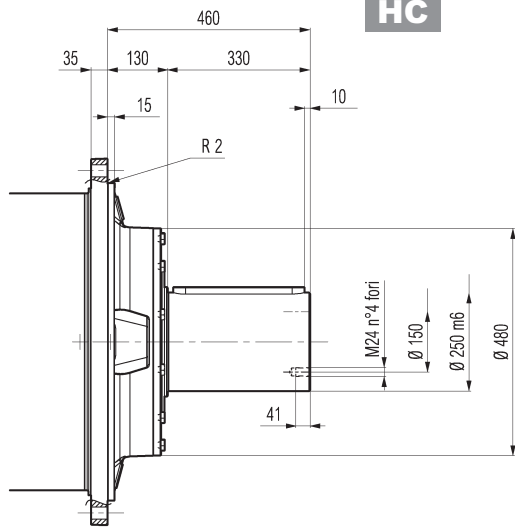

PC

A56x32x310
UNI 6604
DIN 6885

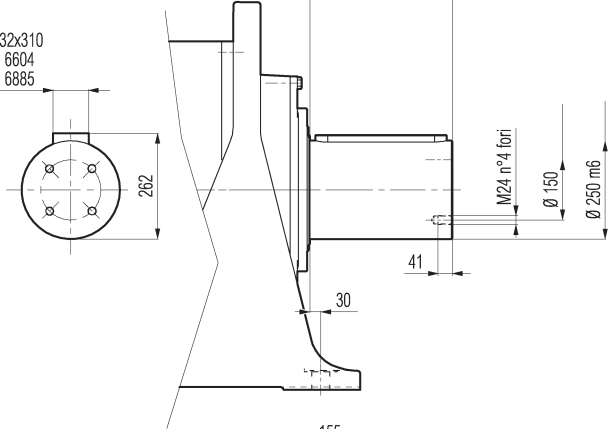

HZ

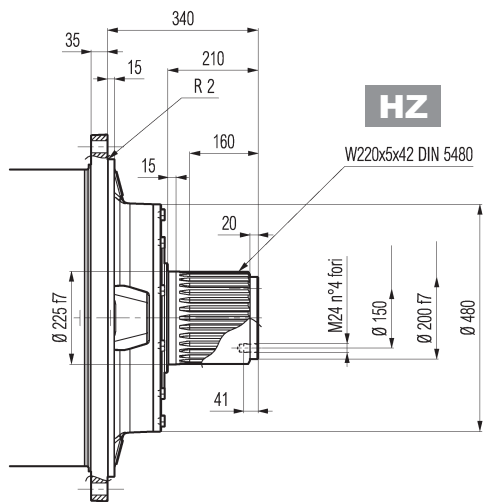

FZ

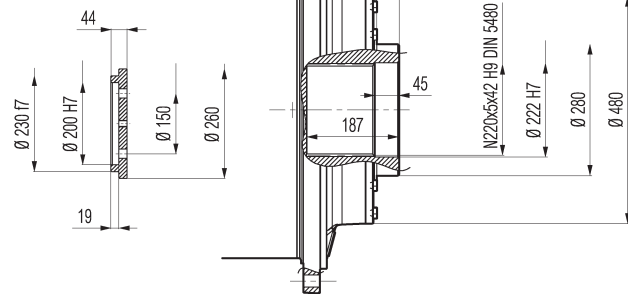

FP

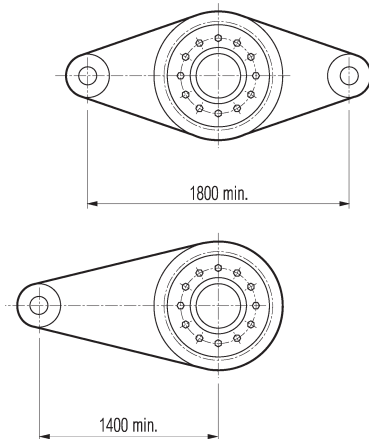
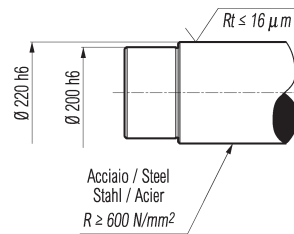
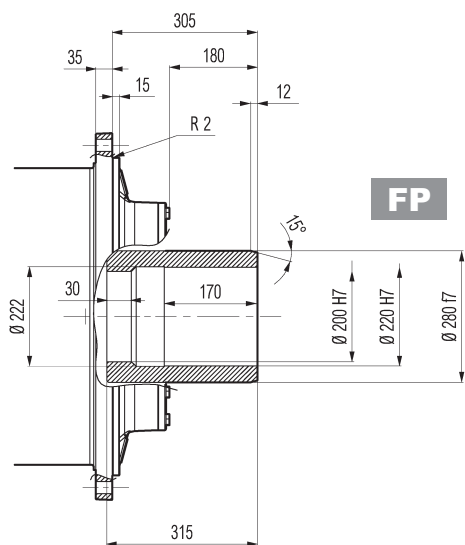

FP

M_{2max} = 300 000 Nm

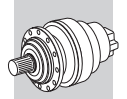
318 L**318 R****3/V 18L4**

Flangia / Flange
Flansch / Brides

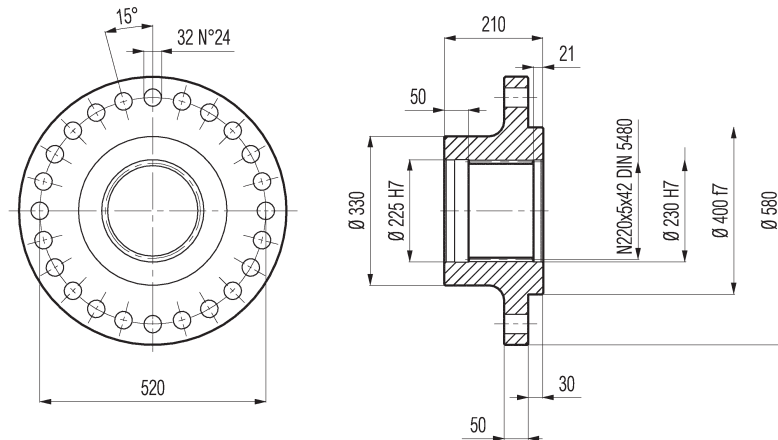
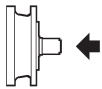
WOA

Materiale : Acciaio C40
Material : Steel C40
Material : Stahl C40
Materiał : Acier C40

Manicotti lisci / Sleeve couplings
Naben / Manchons lisses a cannelure interieure

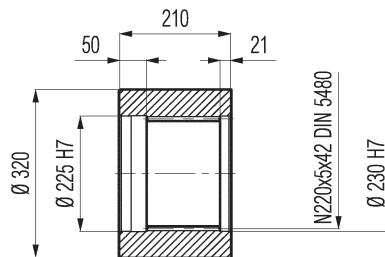
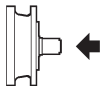
MOA

Materiale : Acciaio C40
Material : Steel C40
Material : Stahl C40
Materiał : Acier C40

Giunto ad attrito / Shrink disc
Schrumpfscheibe / Frette de serrage

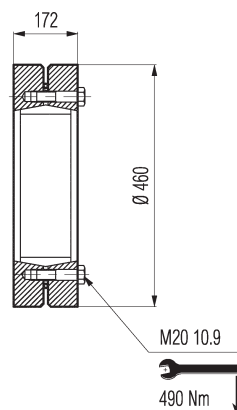
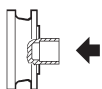
GOA

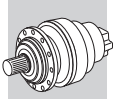

318 L

318 R

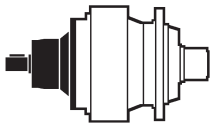
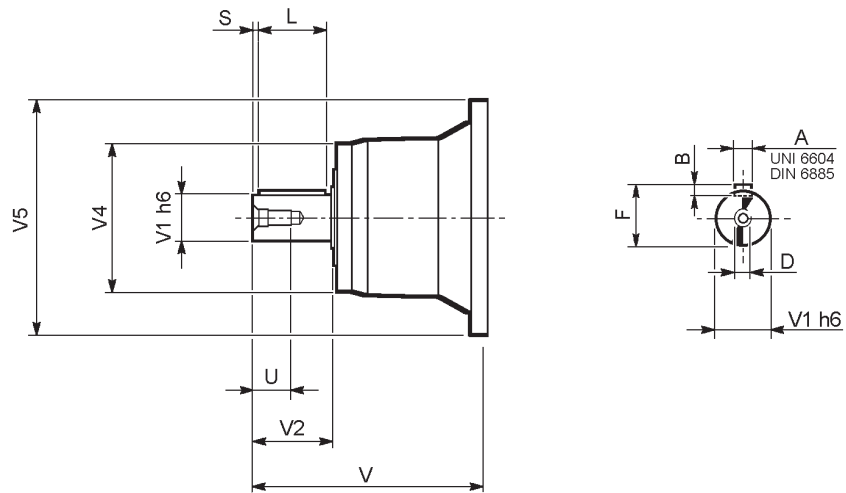

	CODE	V	V1	V2	V4	V5	A	B	F	L	S	D	U
318 L3	V11B	348	80	130	200	428	22	14	85	110	10	M16	36
318 L4	V07A	313	60	105	155	345	18	11	64	90	7.5	M16	36
	V07B	315	80	130	200	345	22	14	85	110	10	M16	36
318 R4 (B) (C)	V06B	307	60	105	155	292	18	11	64	90	7.5	M16	36

3/V 18L4

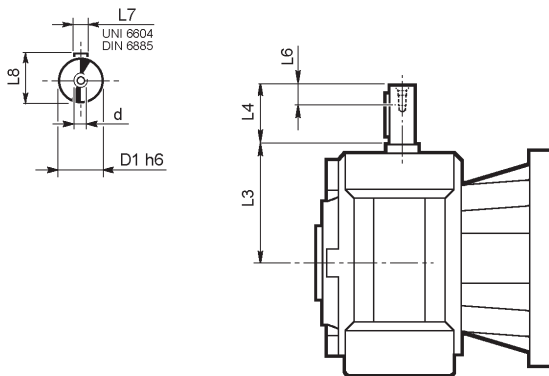

	D1 h6	L3	L4	L6	L7	L8	d
3/V 18L4_HS	48	230	110	40	14	51.5	M16

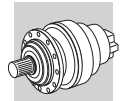

Fattore di posizione per carichi radiali sugli alberi in uscita.

Load location factor for radial loading on output shaft.

Positionsfaktor für Radialkräfte an der Abtriebswelle.

Facteur de position pour charges radiales sur les arbres en sortie.

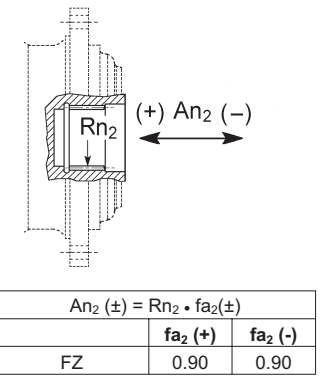
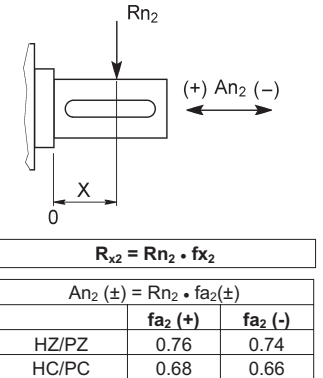
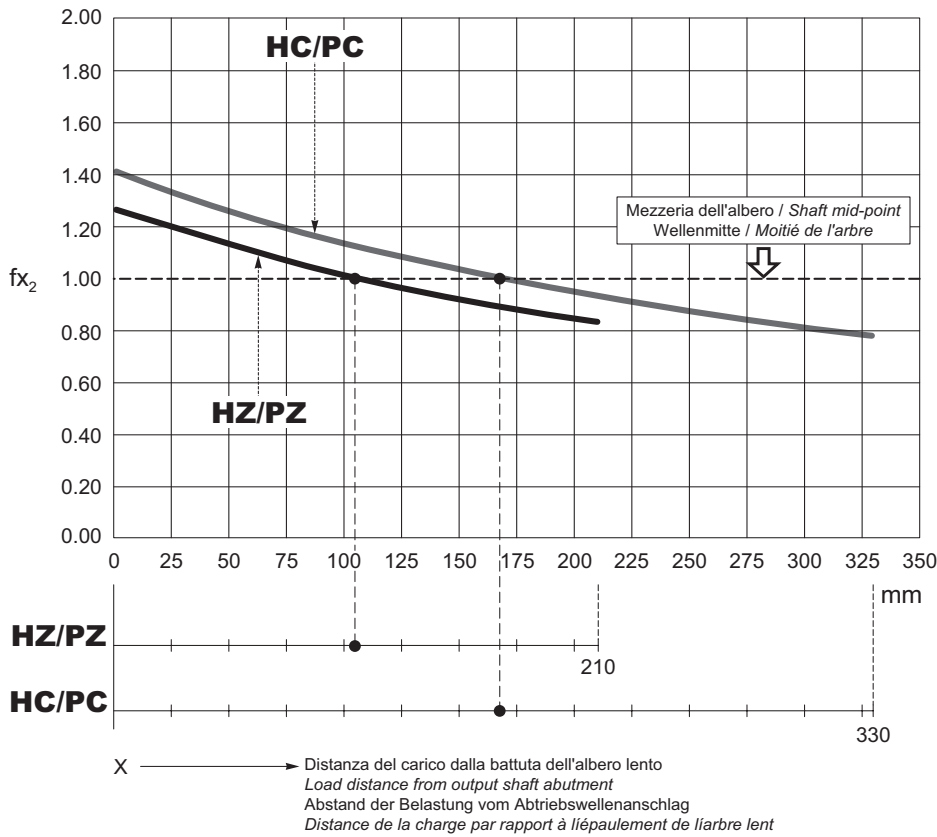

Carichi radiali ammissibili sull'albero veloce per $n_1 = 1000 \text{ min}^{-1}$ e 10000 h di vita teorica.

Permitted overhung loads on input shaft when $n_1 = 1000 \text{ min}^{-1}$ and theoretical lifetime = 10000 h.

Zulässige Radialkräfte an den Antriebswellen für $n_1 = 1000 \text{ min}^{-1}$ und 10000 std.

Charges radiales admissibles sur les arbres d'entrée pour $n_1 = 1000 \text{ min}^{-1}$ et 10000 h.

Per velocità di comando e/o durate diverse vedi il capitolo: Verifiche.

For drive speed and/or lifetimes other than those specified here, see Chapter: Verifications.

Im Hinblick auf Geschwindigkeit und/oder anderweitige Dauern verweisen wir auf Par: Prüfungen

Pour des vitesses et/ou durées différentes, voir par. Vérifications.

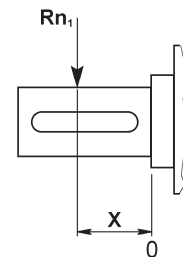
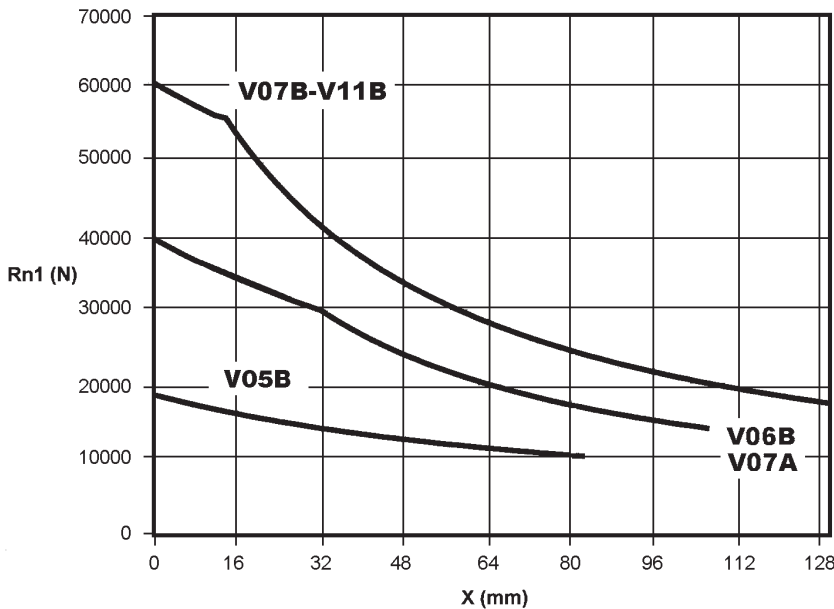

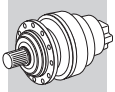

319 L

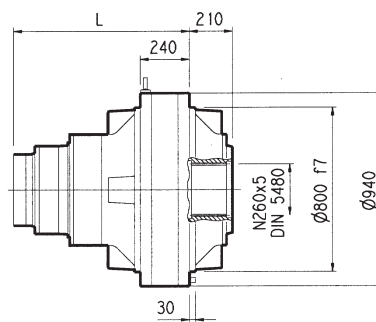
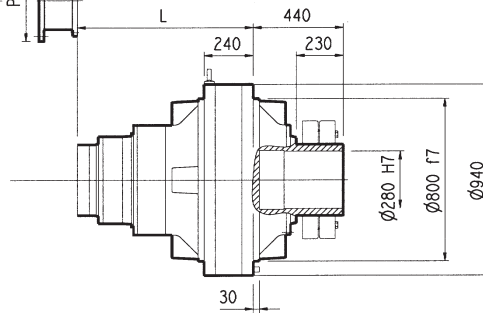
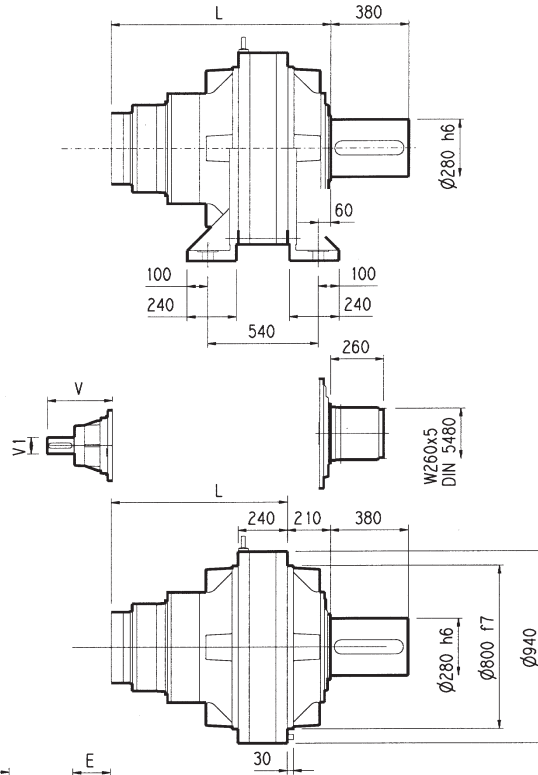
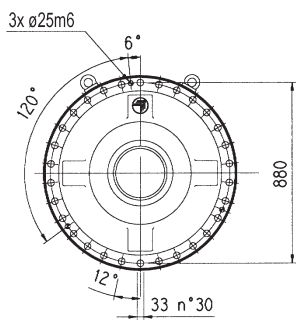
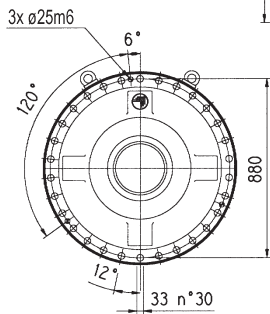
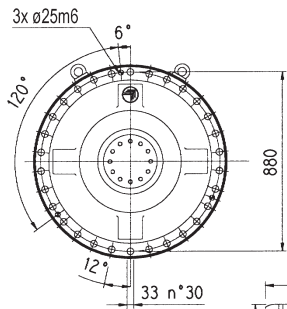
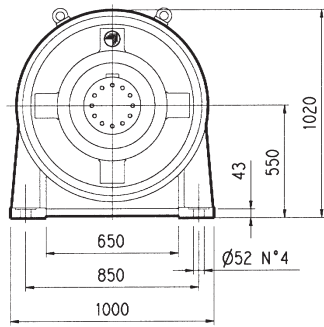

PC

HZ PZ

HC

FP

FZ

FP

$M_{2max} = 420\,000\text{ Nm}$

	L				Kg				Albero veloce / Input shaft Antriebswelle / Arbre d'entrée					
	PC - PZ	HC - HZ	FZ	FP	PC - PZ	HC - HZ	FZ	FP	V	V1	Kg	V	V1	Kg
319 L3	990	780	780	780	2435	2135	2035	2035	348	80	55	-	-	-
319 L4	1123	913	913	913	2480	2180	2080	2080	315	80	35	313	60	28

	P180		P200		P225		P250	
	E	P	E	P	E	P	E	P
319 L4	195	350	186	400	216	450	216	550

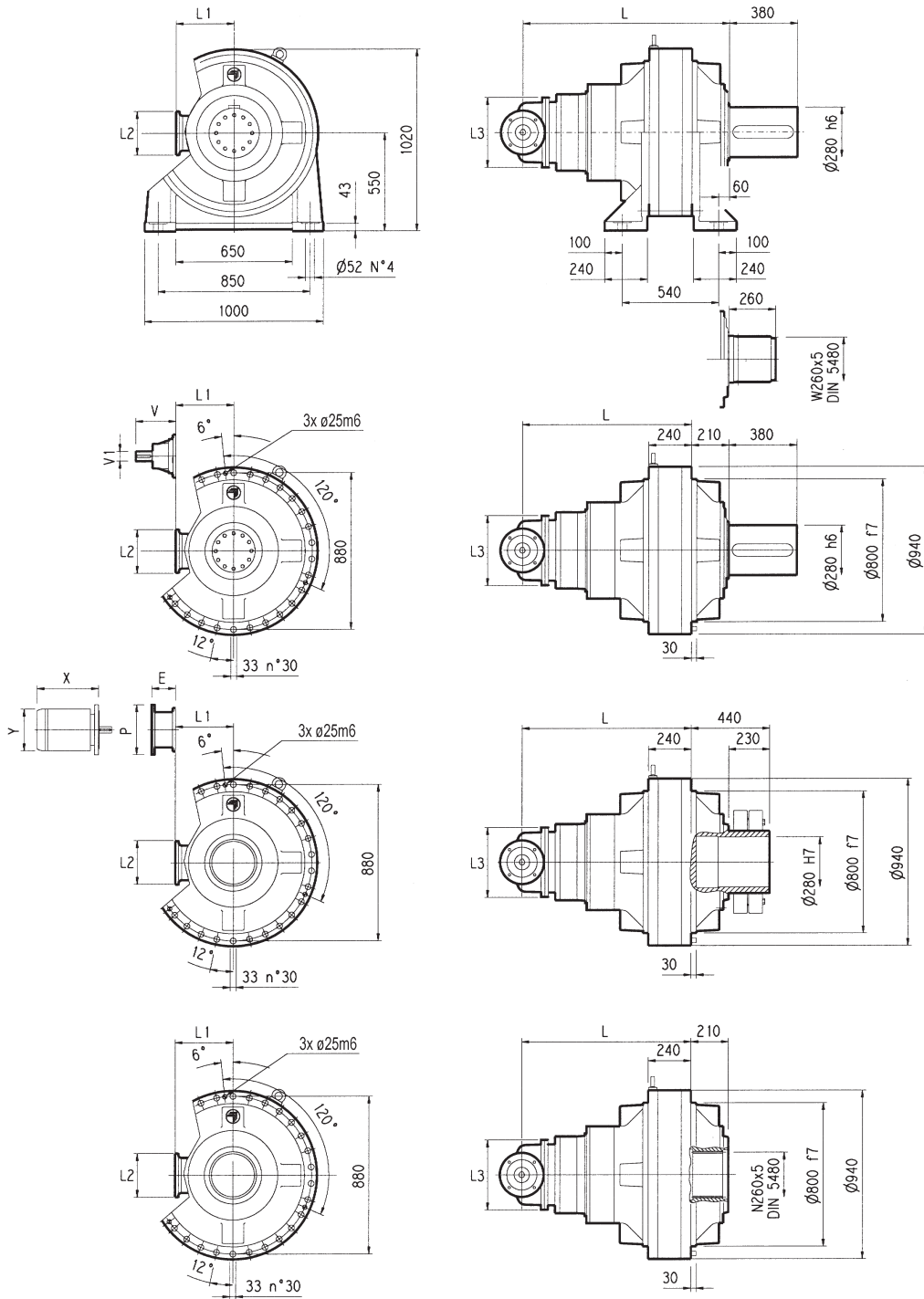
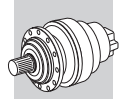

PC

HZ PZ

HC

FP

FZ

FP $M_{2max} = 420\,000\text{ Nm}$

	L				L1	L2	L3	Kg				Albero veloce / Input shaft Antriebswelle / Arbre d'entrée					
	PC - PZ	HC - HZ	FZ	FP				PC - PZ	HC - HZ	FZ	FP	V	V1	Kg	V	V1	Kg
319 R4 (B)	1205	1005	1005	1005	345	292	400	2560	2260	2160	2160	307	60	23	-	-	-
319 R4 (C)	1205	1005	1005	1005	390	292	480	2580	2280	2180	2180	307	60	23	-	-	-
319 R4 (A)	1205	1005	1005	1005	330	245	390	2545	2245	2145	2145	239	48	15	-	-	-

	P132		P160M		P180		P200L		P225		P250	
	E	P	E	P	E	P	E	P	E	P	E	P
319 R4 (B)	-	-	-	-	152	350	182	400	212	450	193	550
319 R4 (C)	-	-	-	-	152	350	182	400	212	450	193	550
319 R4 (A)	114	300	144	350	144	350	174	400	-	-	-	-

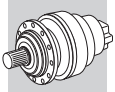

3/V 19L4

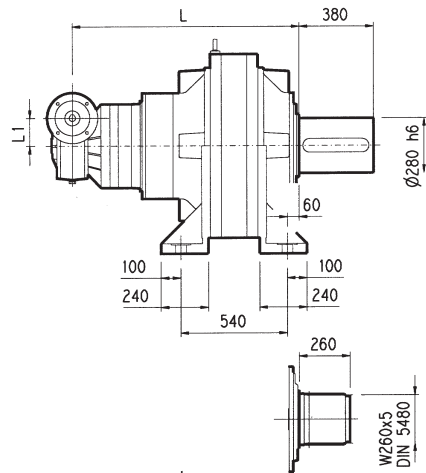
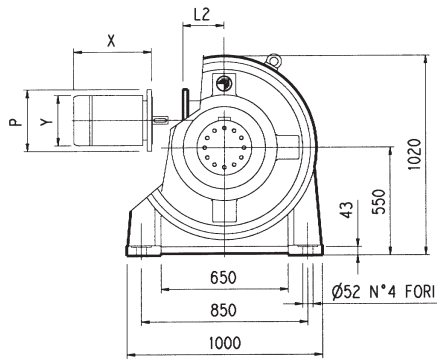

PC

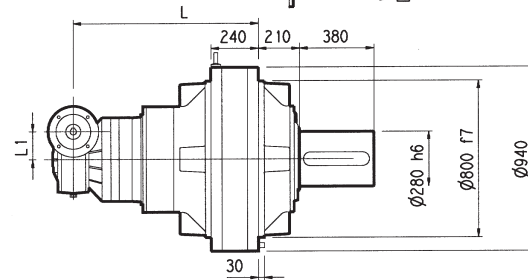
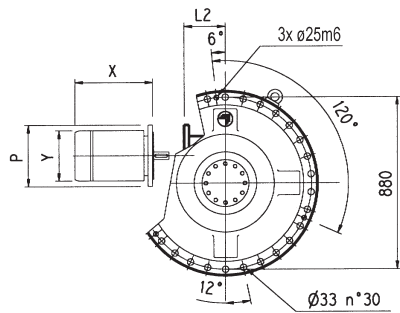

HZ PZ

HC

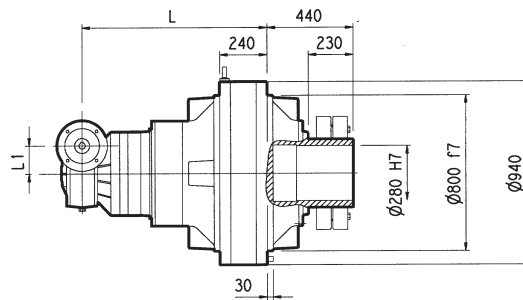
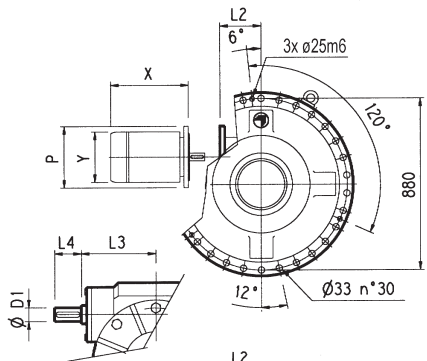

FP

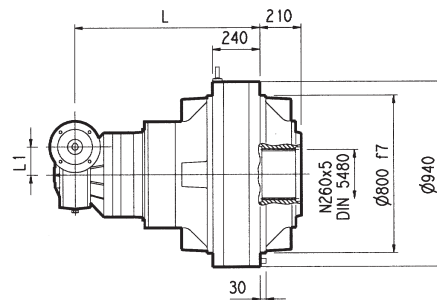
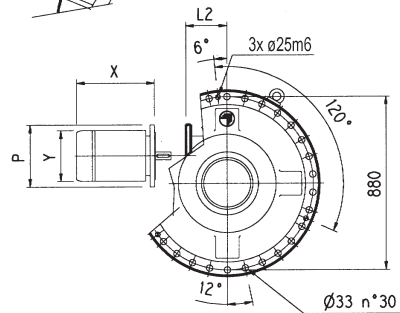

FZ

FP $M_{2max} = 420\,000\text{ Nm}$

	L				L1	D1	L3	L4	Kg			
	PC - PZ	HC - HZ	FZ	FP					PC - PZ	HC - HZ	FZ	FP
3/V 19L4	1210	1000	1000	1000	210	48	230	110	2650	2350	2250	2250
	P132		P160		P180		P200		P225			
	L2	P	L2	P	L2	P	L2	P	L2	P		
3/V 19L4	485	300	460	350	460	350	485	400	490	450		

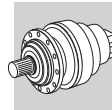

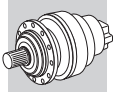

319 L

319 R

3/V 19L4

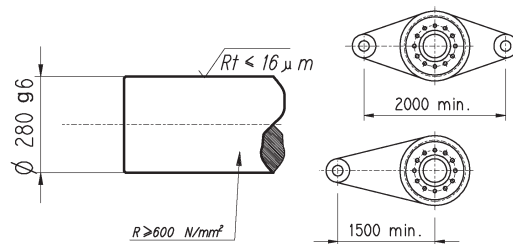
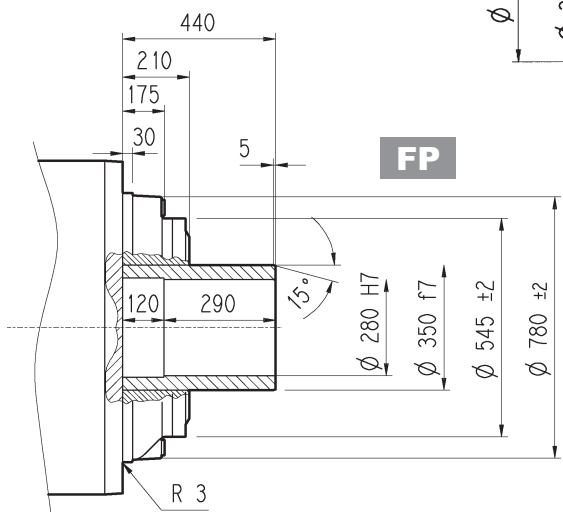
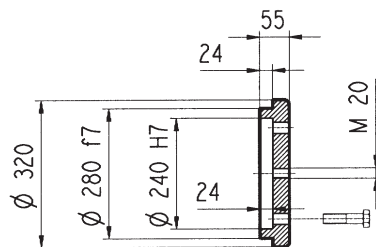
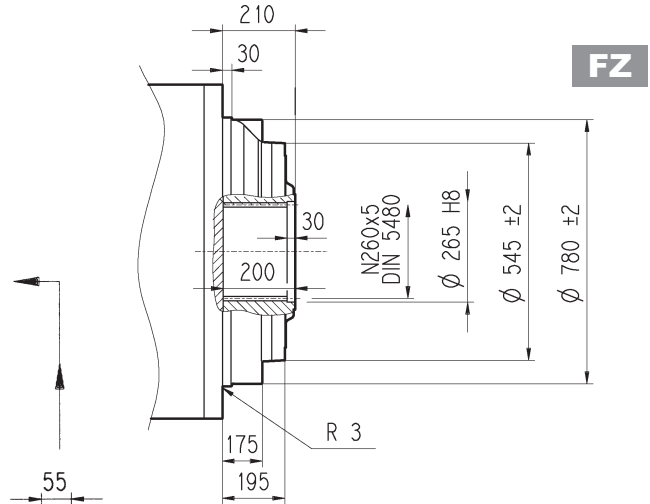
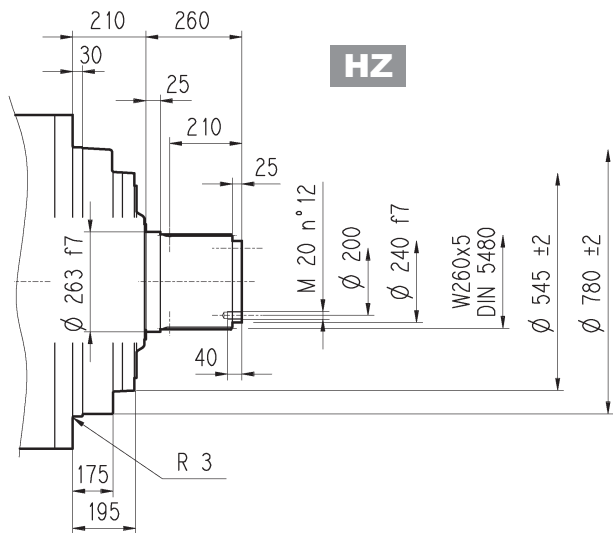
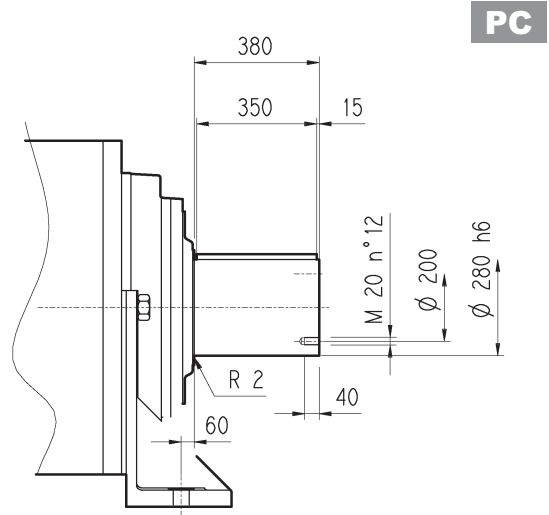
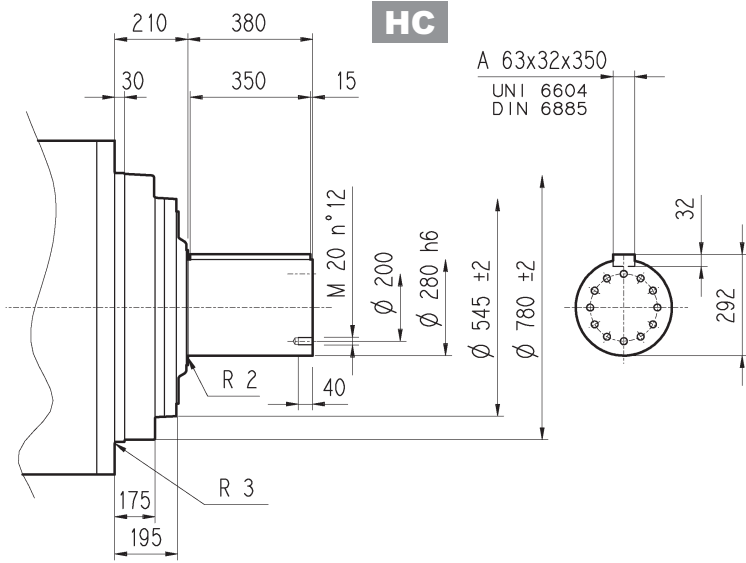

FP

$M_{2max} = 420\,000 \text{ Nm}$

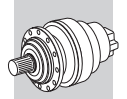
319 L**319 R****3/V 19L4**

Flangia / Flange
Flansch / Brides

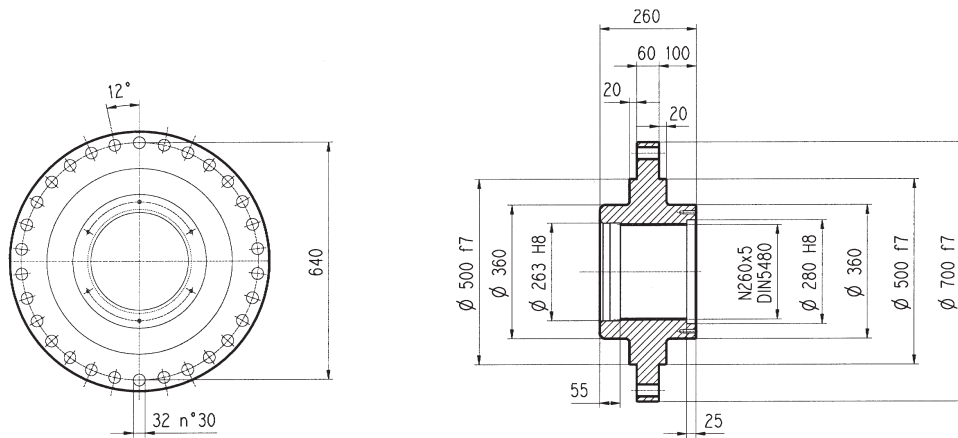
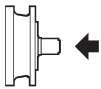
W0A

Materiale : Acciaio C40
 Material : Steel C40
 Material : Stahl C40
 Matière : Acier C40

Manicotti lisci / Sleeve couplings
Naben / Manchons lisses a cannelure interieure

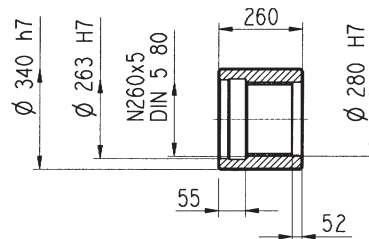
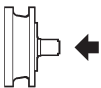
MOA

Materiale : Acciaio 16CrNi4
 Material : Steel 16CrNi4
 Material : Stahl 16CrNi4
 Matière : Acier 16CrNi4

Giunto ad attrito / Shrink disc
Schrumpfscheibe / Frettes de serrage

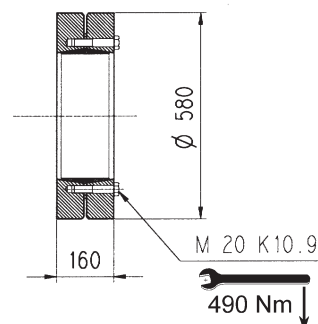
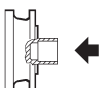
G0A

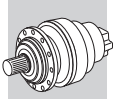

319 L

319 R

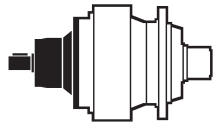
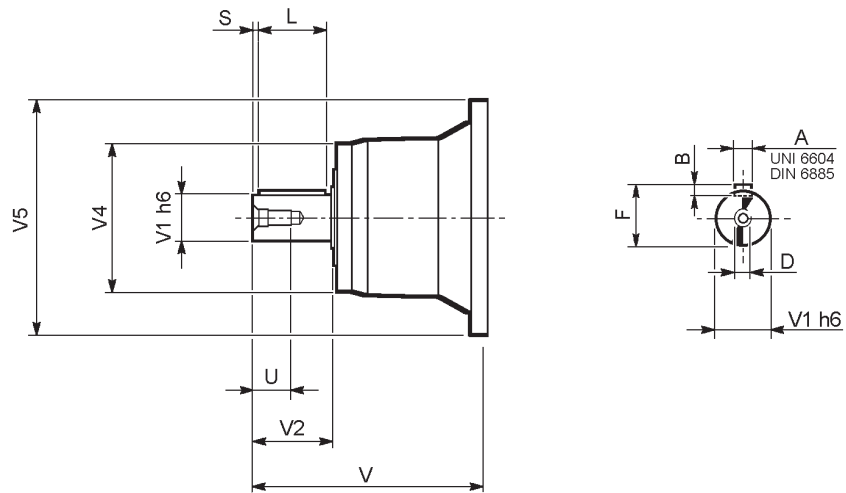

	CODE	V	V1	V2	V4	V5	A	B	F	L	S	D	U
319 L3	V11B	348	80	130	200	428	22	14	85	110	10	M16	36
319 L4	V07A	313	60	105	155	345	18	11	64	90	7.5	M16	36
	V07B	315	80	130	200	345	22	14	85	110	10	M16	36
319 R4 (A)	V05B	239	48	82	155	245	14	9	51.5	70	6	M16	36
319 R4 (B) (C)	V06B	307	60	105	155	292	18	11	64	90	7.5	M16	36

3/V 19L4

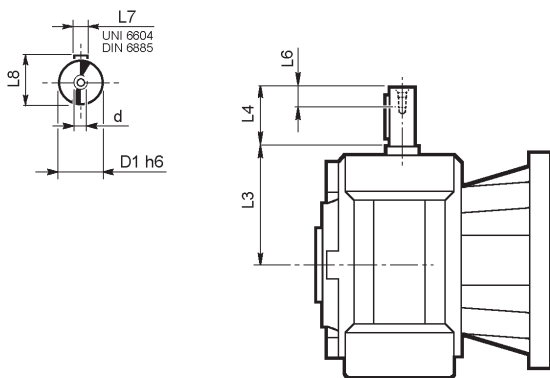

	D1 h6	L3	L4	L6	L7	L8	d
3/V 19L4_HS	48	230	110	40	14	51.5	M16

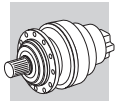

Fattore di posizione per carichi radiali sugli alberi in uscita.

Load location factor for radial loading on output shaft.

Positionsfaktor für Radialkräfte an der Abtriebswelle.

Facteur de position pour charges radiales sur les arbres en sortie.

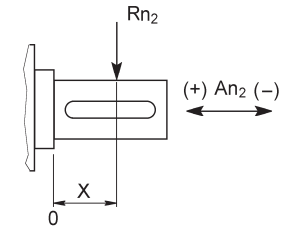
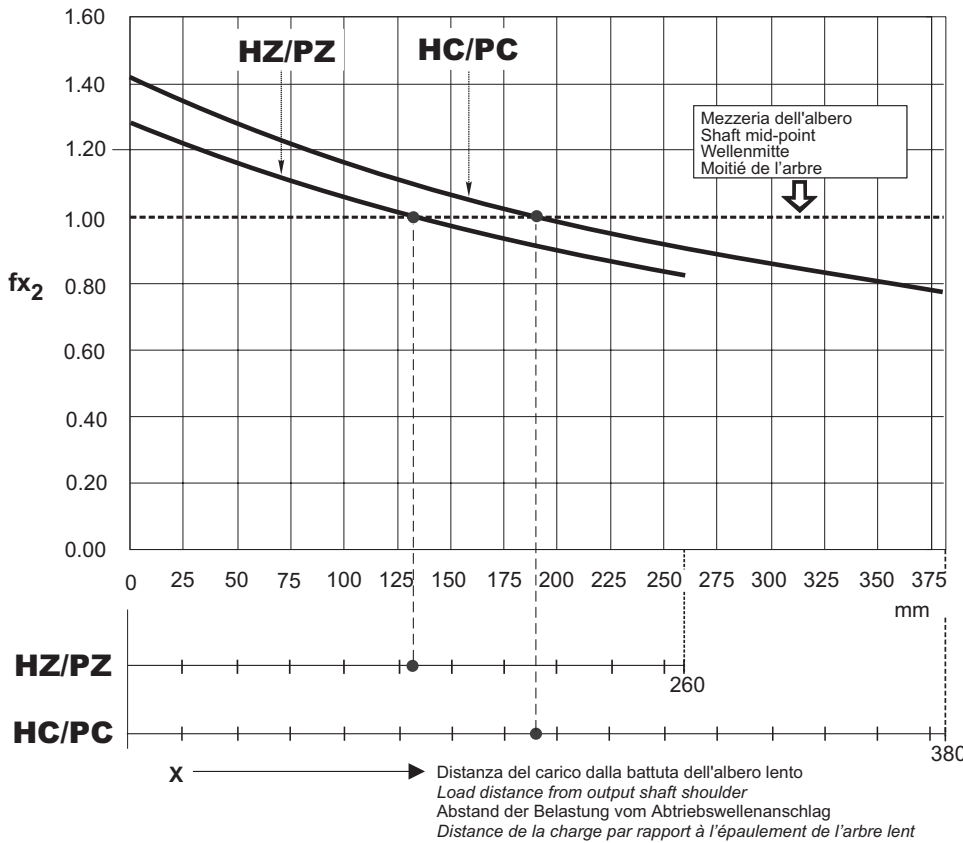

$$R_{x2} = Rn_2 \cdot fx_2$$

$$An_2 (\pm) = Rn_2 \cdot fa_2 (\pm)$$

	fa ₂ (+)	fa ₂ (-)
HZ/PZ	0.71	0.64
HC/PC	0.78	0.71

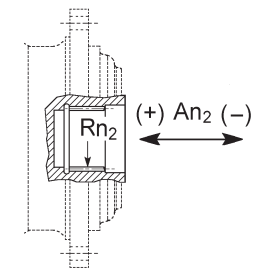

$$An_2 (\pm) = Rn_2 \cdot fa_2 (\pm)$$

	fa ₂ (+)	fa ₂ (-)
FZ	1.00	1.00

Carichi radiali ammissibili sull'albero veloce per $n_1 = 1000 \text{ min}^{-1}$ e 10000 h di vita teorica. Per velocità di comando e/o durate diverse vedi il capitolo: Verifiche.

Permitted overhung loads on input shaft when $n_1 = 1000 \text{ min}^{-1}$ and theoretical lifetime = 10000 h. For drive speed and/or lifetimes other than those specified here, see Chapter: Verifications.

Zulässige Radialkräfte an den Antriebswellen für $n_1 = 1000 \text{ min}^{-1}$ und 10000 std. Im Hinblick auf Geschwindigkeit und/oder anderweitige Dauern verweisen wir auf Par: Prüfungen

Charges radiales admissibles sur les arbres d'entrée pour $n_1 = 1000 \text{ min}^{-1}$ et 10000 h. Pour des vitesses et/ou durées différentes, voir par. Vérifications.

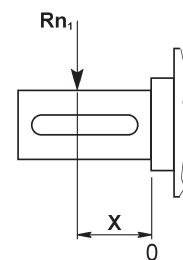
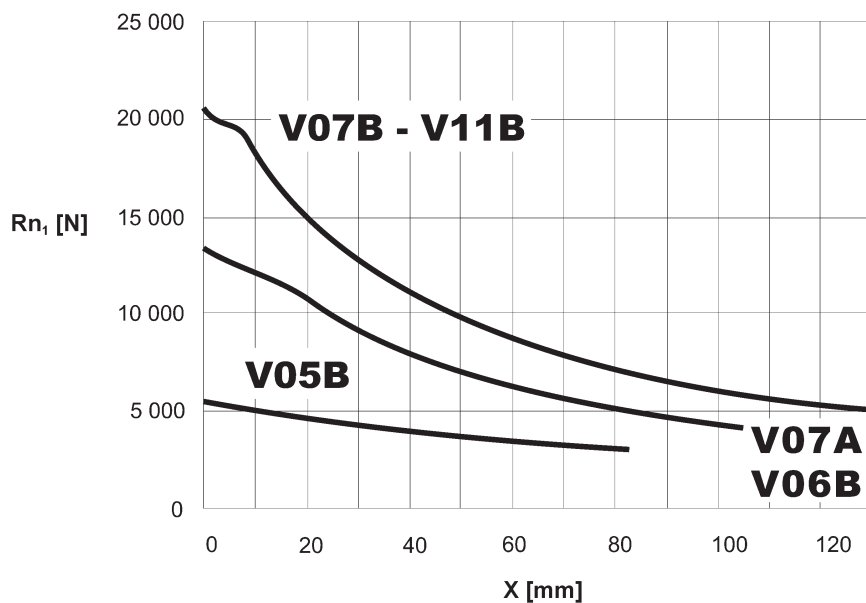

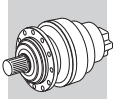

321 L

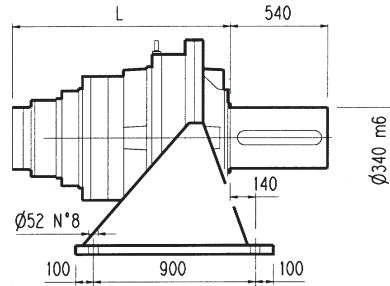
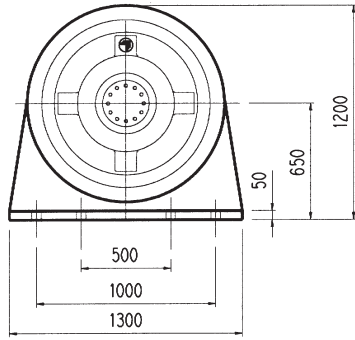

PC

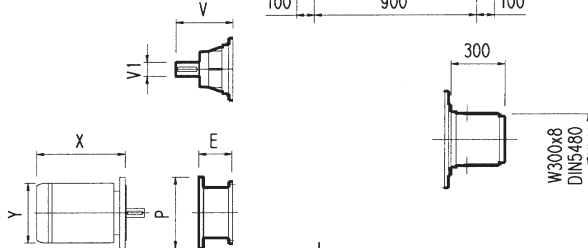

HZ PZ

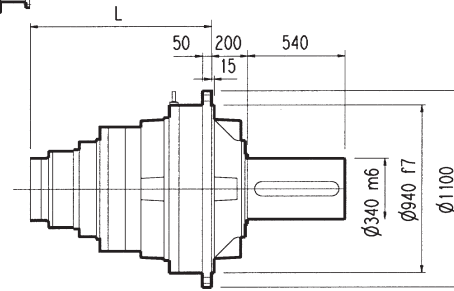
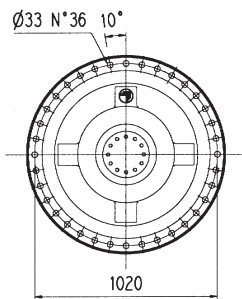

HC

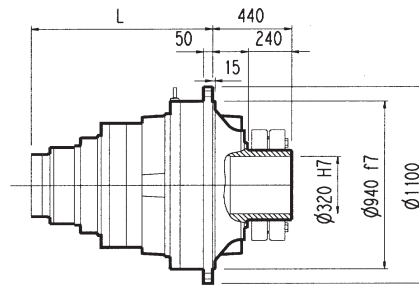
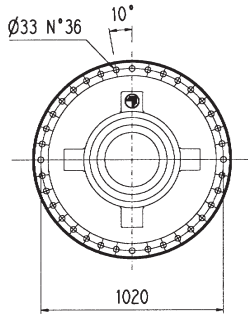

FP

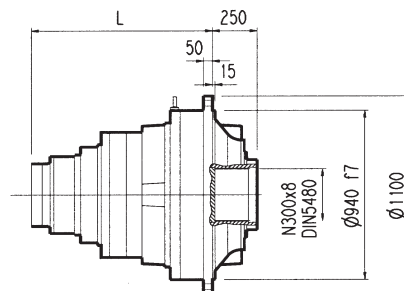
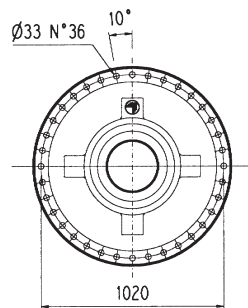

FZ

FP

M_{2max} = 648 000 Nm

	L				Kg				Albero veloce / Input shaft Antriebswelle / Arbre d'entrée					
	PC - PZ	HC - HZ	FZ	FP	PC - PZ	HC - HZ	FZ	FP	V	V1	Kg	V	V1	Kg
321 L3	1104	904	904	904	3120	2820	2720	2720	343	80	55	-	-	-
321 L4	1253	1053	1053	1053	3180	2880	2780	2780	315	80	35	313	60	28

	P180		P200		P225		P250	
	E	P	E	P	E	P	E	P
321 L4	195	350	186	400	216	450	216	550

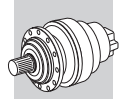

PC

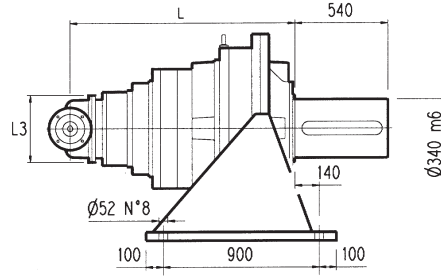
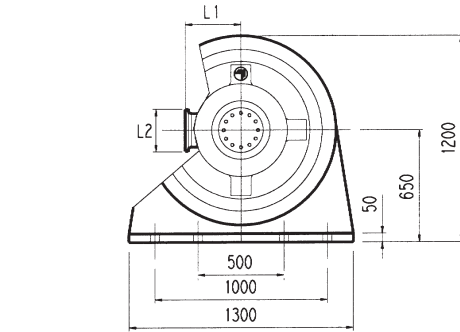

HZ PZ

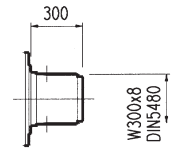
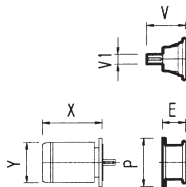

HC

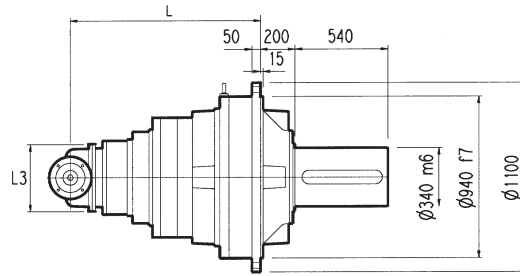
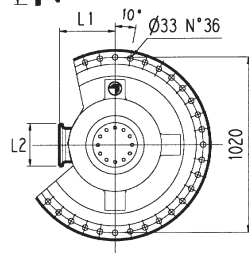

FP

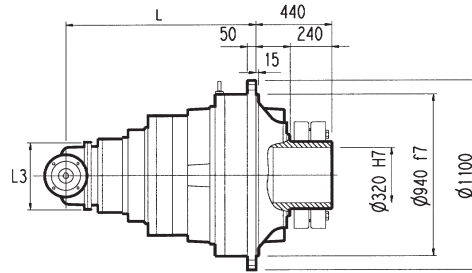
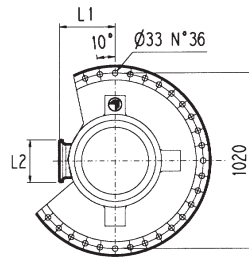

FZ

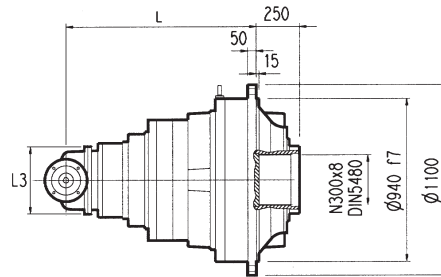
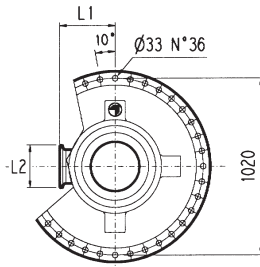

FP $M_{2max} = 648\,000\text{ Nm}$

	L				L1	L2	L3	Kg				Albero veloce / Input shaft Antriebswelle / Arbre d'entrée					
	PC - PZ	HC - HZ	FZ	FP				PC - PZ	HC - HZ	FZ	FP	V	V1	Kg	V	V1	Kg
321 R4 (B)	1334	1134	1134	1134	345	292	400	3250	2950	2850	2850	307	60	23	-	-	-
321 R4 (C)	1334	1134	1134	1134	390	292	480	3260	2960	2860	2860	307	60	23	-	-	-
321 R4 (A)	1334	1134	1134	1134	330	245	390	3230	2930	2830	2830	239	48	15	-	-	-

	P132		P160M		P180		P200L		P225		P250	
	E	P	E	P	E	P	E	P	E	P	E	P
321 R4 (B)	-	-	-	-	152	350	182	400	212	450	193	550
321 R4 (C)	-	-	-	-	152	350	182	400	212	450	193	550
321 R4 (A)	114	300	144	350	144	350	174	400	-	-	-	-

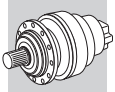

3/V 21L4

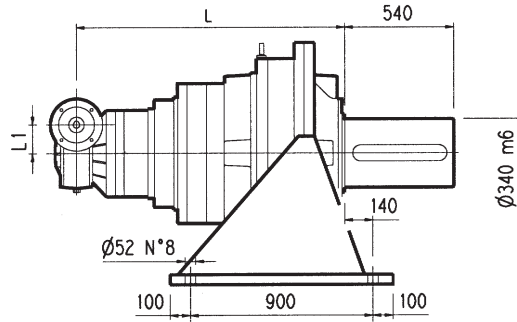
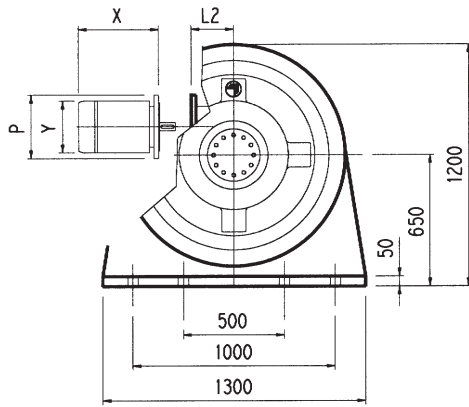

PC

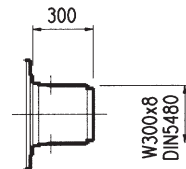

HZ PZ

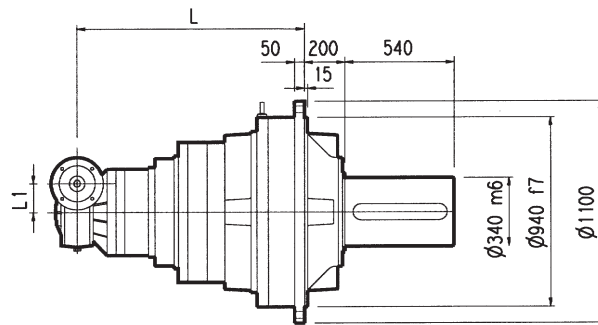
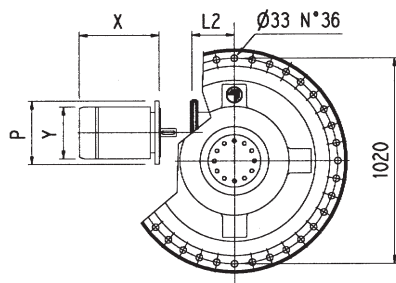

HC

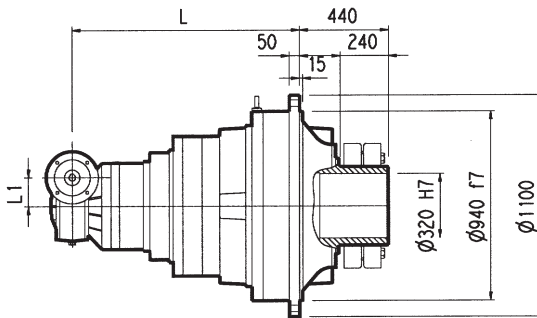
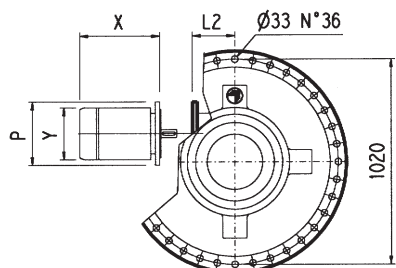

FP

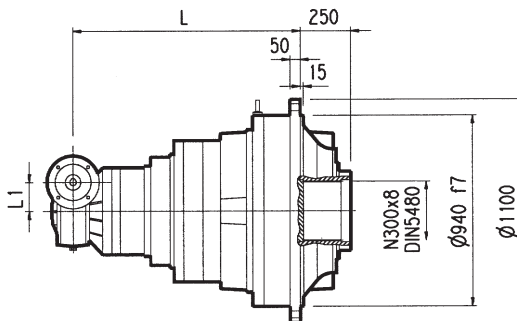
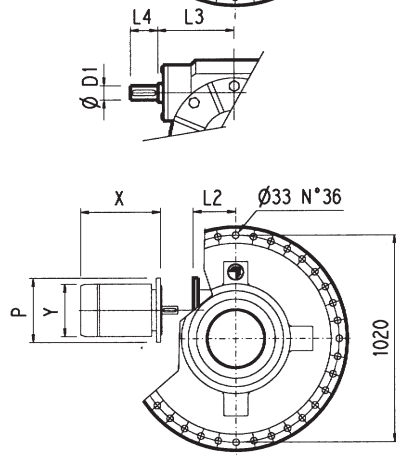

FZ

FP

$M_{2max} = 648\,000\text{ Nm}$

	L				L1	L2	D1	L3	L4	Kg			
	PC - PZ	HC - HZ	FZ	FP						PC - PZ	HC - HZ	FZ	FP
3/V 21L4	1374	1174	1174	1174	250	-	55	276	110	3430	3130	3030	3030
	P132		P160		P180		P200		P225				
	L2	P	L2	P	L2	P	L2	P	L2	P			
3/V 21L4	531	300	506	350	506	350	531	400	536	450			

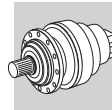

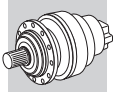

321 L

321 R

3/V 21L4

HC

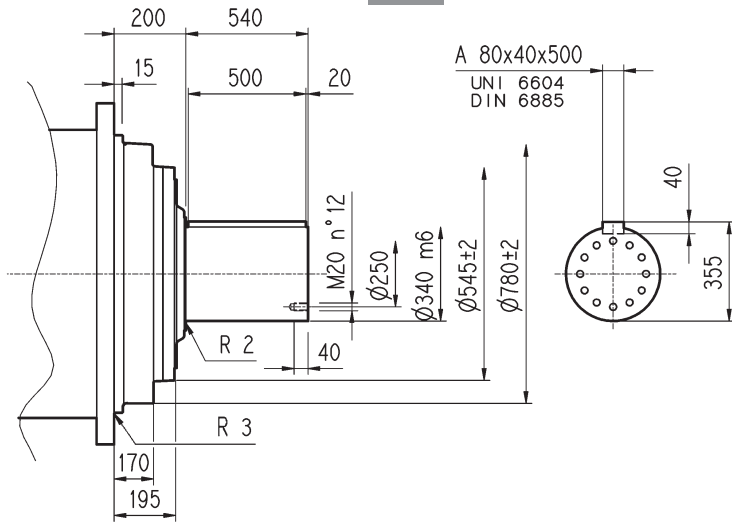

PC

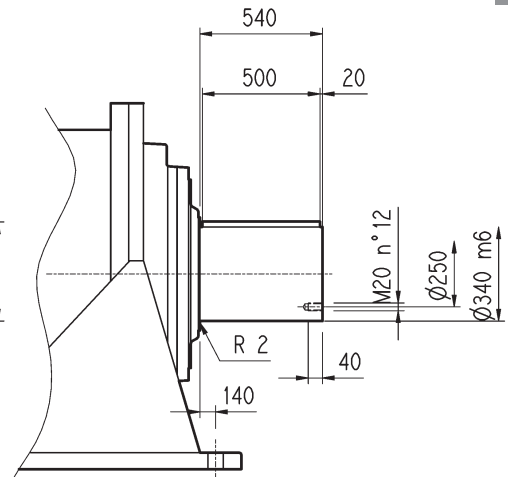

HZ

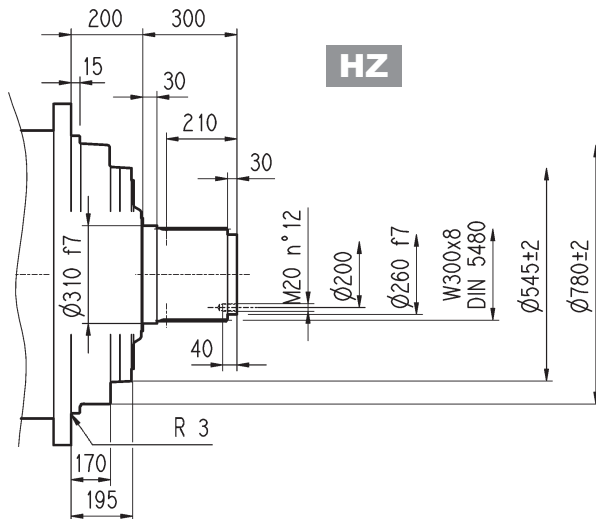

FZ

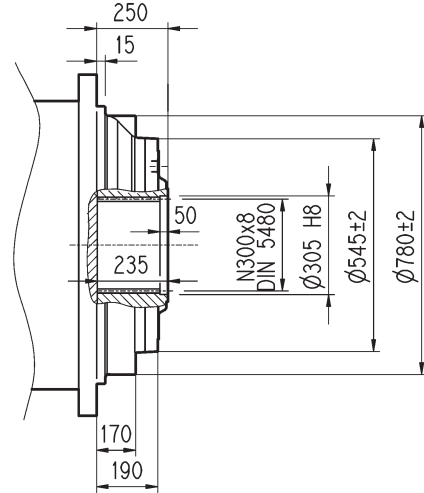

FP

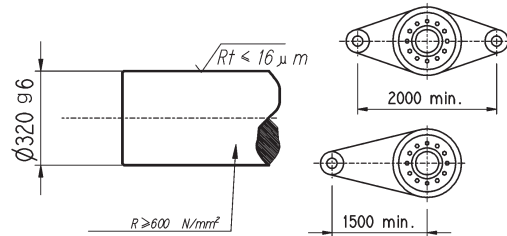
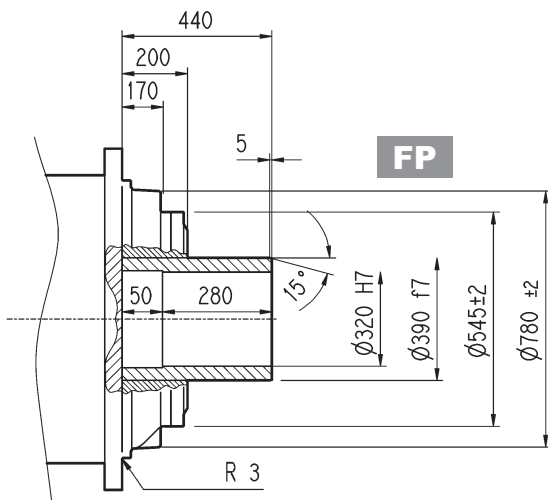

FP

$M_{2max} = 648\,000 \text{ Nm}$

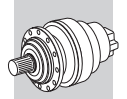
321 L**321 R****3/V 21L4**

Flangia / Flange
Flansch / Brides

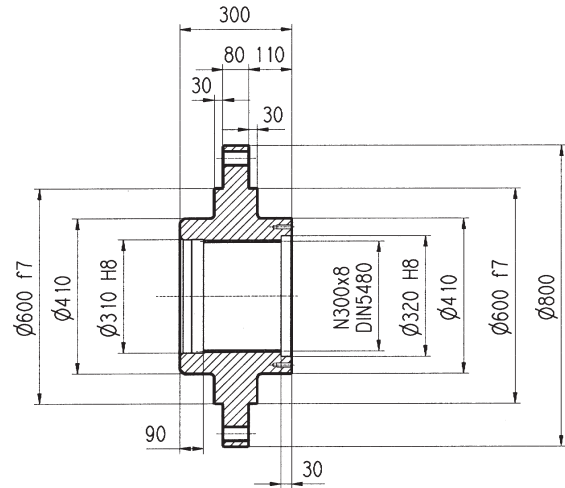
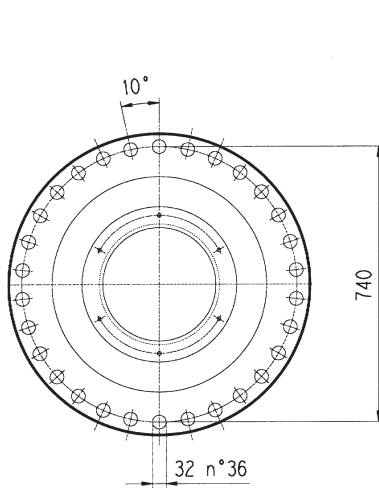
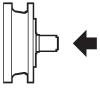
W0A

Materiale : Acciaio C40
Material : Steel C40
Material : Stahl C40
Materia : Acier C40

Giunto ad attrito / *Shrink disc*
Schrumpfscheibe / *Frette de serrage*

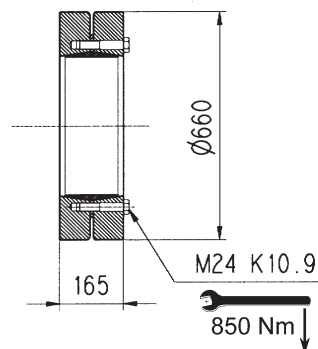
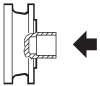
G0A

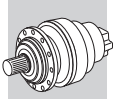

321 L

321 R

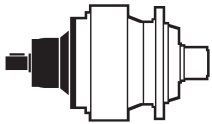
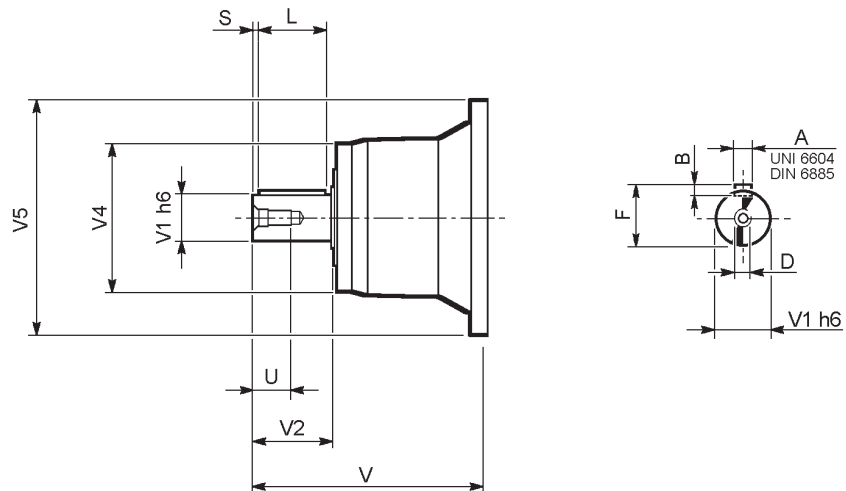

	CODE	V	V1	V2	V4	V5	A	B	F	L	S	D	U
321 L3	V11B	343	80	130	200	445	22	14	85	110	10	M16	36
321 L4	V07B	315	80	130	200	345	22	14	85	110	10	M16	36
	V07A	313	60	105	155	345	18	11	64	90	7.5	M16	36
321 R4 (A)	V05B	239	48	82	155	245	14	9	51.5	70	6	M16	36
321 R4 (B) (C)	V06B	307	60	105	155	292	18	11	64	90	7.5	M16	36

3/V 21L4

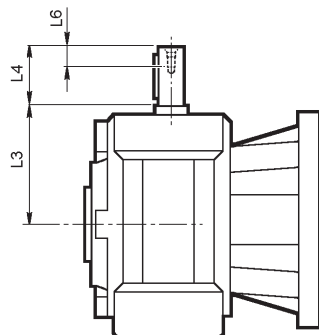
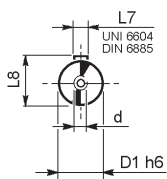

	D1 h6	L3	L4	L6	L7	L8	d
3/V 21L4_HS	55	276	110	40	16	59	M16

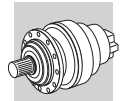

Fattore di posizione per carichi radiali sugli alberi in uscita.

Load location factor for radial loading on output shaft.

Positionsfaktor für Radialkräfte an der Abtriebswelle.

Facteur de position pour charges radiales sur les arbres en sortie.

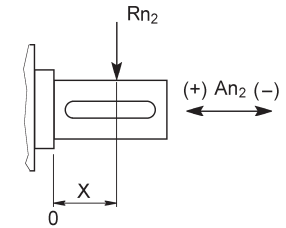
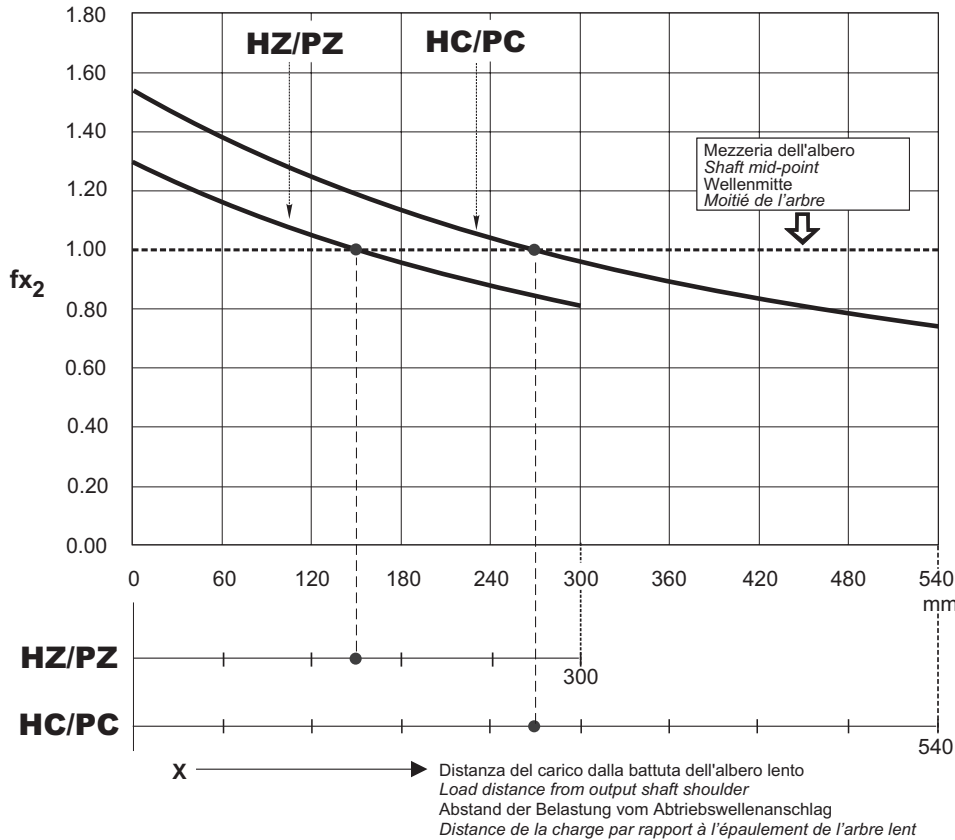

$$R_{x2} = R_{n2} \cdot f_{x2}$$

$$A_{n2} (\pm) = R_{n2} \cdot f_{a2} (\pm)$$

	$f_{a2} (+)$	$f_{a2} (-)$
HZ/PZ	0.20	0.26
HC/PC	0.23	0.31

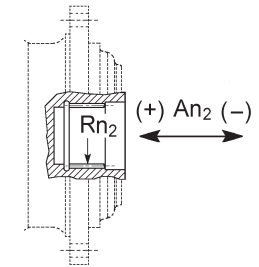

$$A_{n2} (\pm) = R_{n2} \cdot f_{a2} (\pm)$$

	$f_{a2} (+)$	$f_{a2} (-)$
FZ	0.15	0.15

Carichi radiali ammissibili sull'albero veloce per $n_1 = 1000 \text{ min}^{-1}$ e 10000 h di vita teorica.

Per velocità di comando e/o durate diverse vedi il capitolo: Verifiche.

Permitted overhung loads on input shaft when $n_1 = 1000 \text{ min}^{-1}$ and theoretical lifetime = 10000 h.

For drive speed and/or lifetimes other than those specified here, see Chapter: Verifications.

Zulässige Radialkräfte an den Antriebswellen für $n_1 = 1000 \text{ min}^{-1}$ und 10000 std.

Im Hinblick auf Geschwindigkeit und/oder anderweitige Dauern verweisen wir auf Par: Prüfungen

Charges radiales admissibles sur les arbres d'entrée pour $n_1 = 1000 \text{ min}^{-1}$ et 10000 h.

Pour des vitesses et/ou durées différentes, voir par. Vérifications.

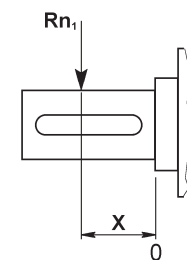
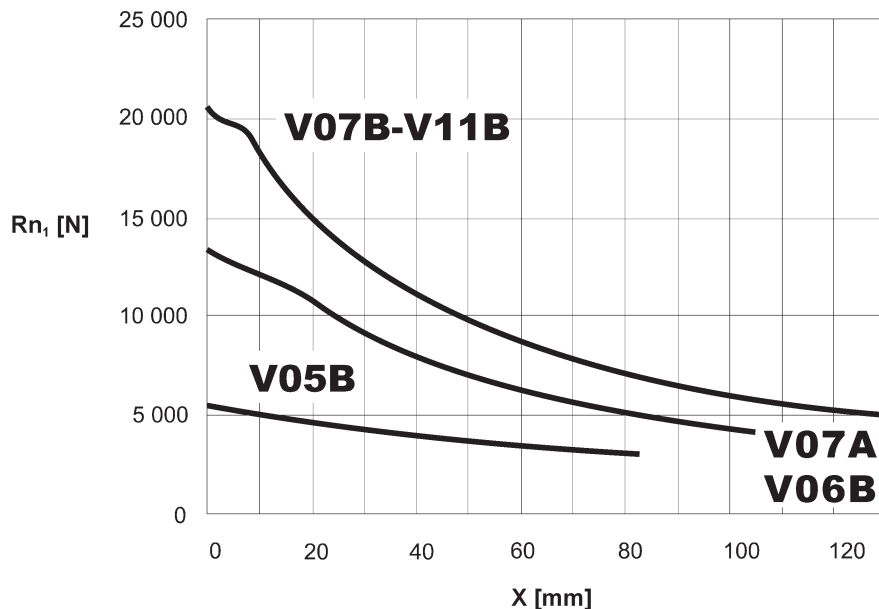

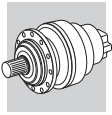

29.0 - SISTEMI AUSILIARI DI RAFFREDDAMENTO

Qualora la potenza meccanica trasmessa sia superiore a quella termica trasmissibile (vedi tabelle dati tecnici motoriduttori e riduttori), è possibile fornire il riduttore corredato di centralina di raffreddamento.

29.0 - SUPPLEMENTARY COOLING SYSTEMS

Should the transmitted mechanical power be greater than the thermal capacity the unit is rated for, supplementary cooling systems can be specified.

29.0 - HILFSKÜHLSYSTEME

Sollte die übertragende mechanische Leistung über der übertragbaren Wärmeleistung liegen (siehe Tabelle mit technischen Getriebedaten), ist die Lieferung eines, mit einem Kühlsystem ausgestatteten Getriebe möglich.

29.0 - SYSTEMES AUXILIAIRES DE REFROIDISSEMENT

Au cas où la puissance mécanique transmise serait supérieure à celle thermique transmissible (confronter tableaux données techniques réducteurs), il est possible de d'équiper le réducteur d'une unité de refroidissement.

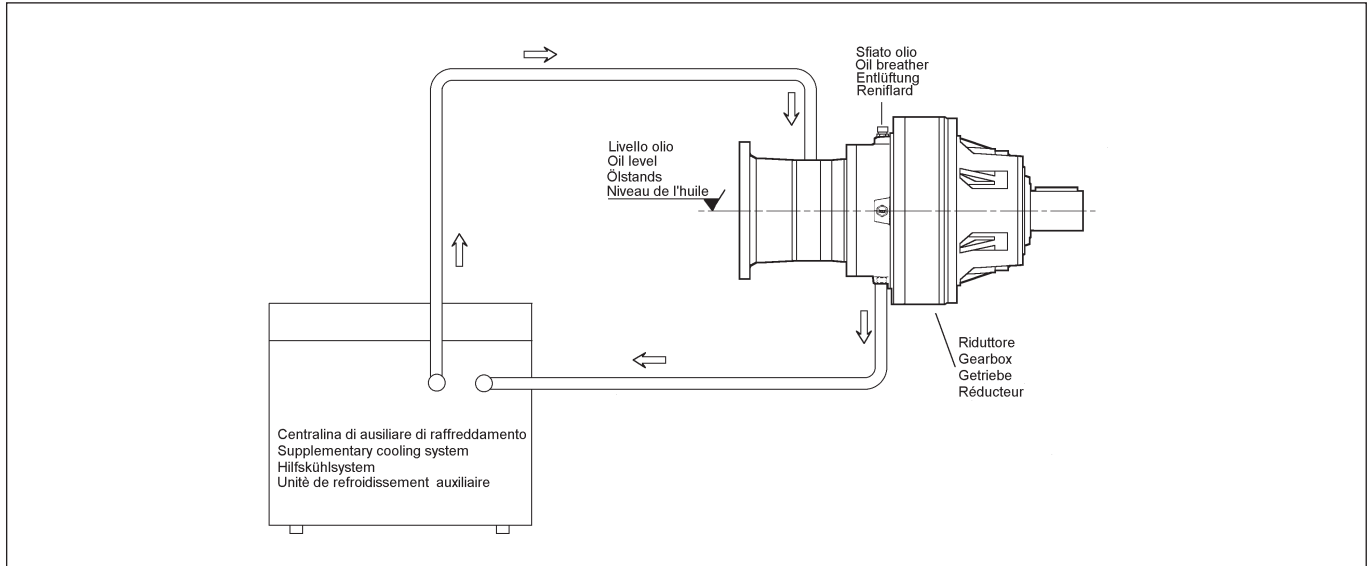

Le centraline autonome di raffreddamento sono unità composte da uno scambiatore di calore aria-olio, una motopompa, un filtro dell'olio da raffreddare, un elettroventilatore ed un impianto elettrico comprendente la protezione termica dei motori elettrici. Caratteristica delle centraline è il basso livello di rumorosità.

Independent cooling systems are made up of an air-oil heat exchanger, a motor pump, a filter and an electric system that incorporates a thermostatic sensor that protects the electric motor. Cooling units are particularly quite in operation.

Die autonomen Kühlsysteme sind Einheiten, die sich aus einem Luft-Öl-Wärmeaustauscher, einer Motorpumpe, einem Filter für das zu kühlende Öl, einem Elektroventilator und einer elektrischen Anlage, welche den Wärmeschutz der Elektromotoren enthält, zusammensetzen.

Les unités indépendantes de refroidissement sont des sous-ensembles se composant d'un échangeur de chaleur air/huile, d'une motopompe, d'un filtre pour l'huile à refroidir, d'un électroventilateur et d'un système électrique incluant une protection thermique des moteurs électriques. Cette unité est caractérisée par un bas niveau de nuisance sonore.

29.1 Dati tecnici

29.1 Technical data

29.1 Technische daten

29.1 Donnée techniques

		CR1	CR2	CR3
Potenza assorbita / Absorbed power Leistungsaufn / Puissance absorbée	[kW]	0.25	0.63	1
Portata pompa / Oil flow rate Pumpeausflussmenge / Débit de pompe	[l/min]	9	25	40
Portata aria / Air flow rate Luftausflussmenge / Débit d'air	[m³/h]	600	1000	3000
Livello di rumorosità a 1 metro / Noise level at 1m Geräuschpegel / Niveau sonore à 1 mètre	[dB(A)]	67	71	76
Peso / Weight Gewicht / Poids	[Kg]	28	40	63

29.2 Criteri di scelta

Nota la potenza da trasmettere P e verificato che questa sia superiore alla potenza termica Pt, calcolare la potenza da smaltire Ps con la formula:

29.2 Selection criteria

If the mechanical power P is greater than the thermal rating Pt, the heating to be dissipated [Ps] can be calculated through the following equation:

29.2 Auswahlkriterien

Hat man einmal die Date der zu übertragenden Leistung P zur Verfügung stehen und überprüft, ob diese über der Wärmeleistung Pt liegt, muß man die Überleistung Ps unter Anwendung der folgenden Formel berechnen:

29.2 Critères de sélection

La puissance P à transmettre connue, et une fois vérifié que celle-ci est supérieure à la puissance thermique Pt, calculer la puissance à éliminer Ps par la formule :

$$P_S = 0.1 \times (P_{r1} - P_t)$$

(28)

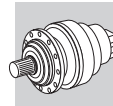

Selezionare la grandezza della centralina sul diagramma (D01) in funzione della temperatura ambiente t_a (20° - 40°C). Verificare che la centralina sia installabile sul riduttore selezionato (vedi tabella D02). In caso contrario, contattare la ns. Organizzazione di vendita.

Select cooling system size in chart (D01) according to ambient temperature t_a (20° - 40°C). Check that the cooling system you have selected will fit the gearbox (see table D02). If this is not the case, contact our sales organization.

Die Größe des Systems auf dem Diagramm (D01) in Abhängigkeit der Umgebungstemperatur t_a (20° - 40°C) auswählen. Überprüfen, ob die Zentrale auch auf dem ausgewählten Getriebe installierbar ist (siehe Tabelle D02). Ist dies nicht der Fall, müssen Sie sich mit unserem Verkaufsnetz in Verbindung setzen.

Sélectionner la taille de l'unité sur le diagramme (D01), se rapportant à la température ambiante (20° - 40°C). Veiller à ce que l'unité puisse être installée sur le réducteur sélectionné (voir tableau D02). Vice versa, contacter notre réseau de vente.

(D01)

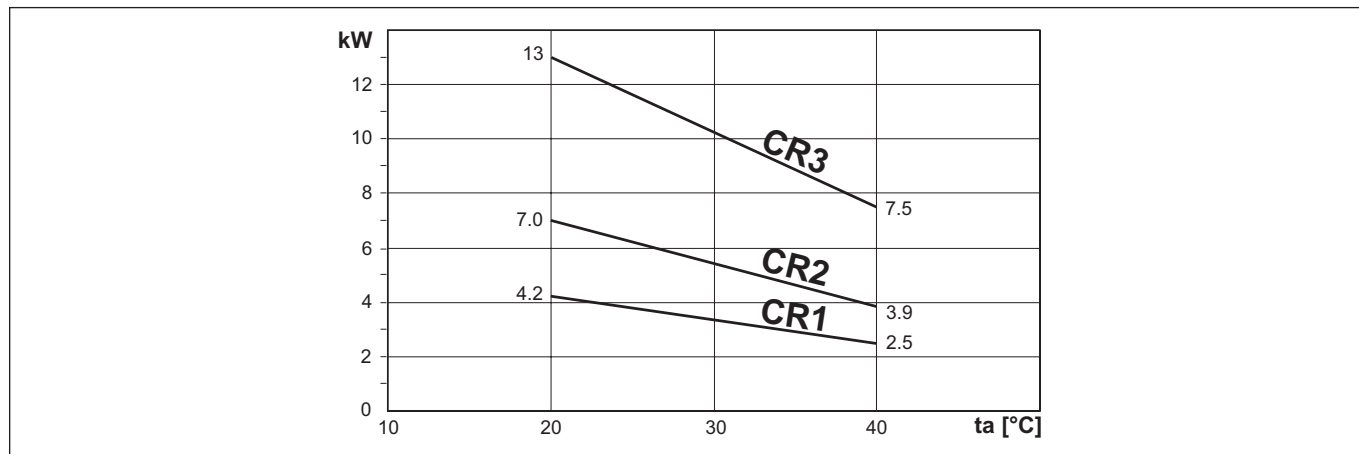

(D02)

Riduttore / Gearbox Getriebe / Réducteur	L1	L2	L3	L4	R2	R3	R4
306	CR1	CR1	—	—	—	—	—
307	CR1	CR1	—	—	CR1	—	—
309	CR1	CR1	CR1	—	CR1	—	—
310	CR2	CR1	CR1	—	—	CR1	—
311	CR2	CR1	CR1	—	CR1	CR1	—
313	CR2	CR1	CR1	—	CR1	CR1	—
315	CR3	CR2	CR1	—	CR1	CR1	—
316	CR3	CR2	CR1	—	CR1	CR1	—
317	CR3	CR2	CR2	CR1	—	—	—
318	CR3	CR2	CR2	CR1	—	—	—
319	CR3	CR2	CR2	CR1	—	—	—
321	CR3	CR2	CR2	CR2	—	—	—

29.3 Dimensioni

29.3 Dimensions

29.3 Abmessungen

29.3 Dimensions

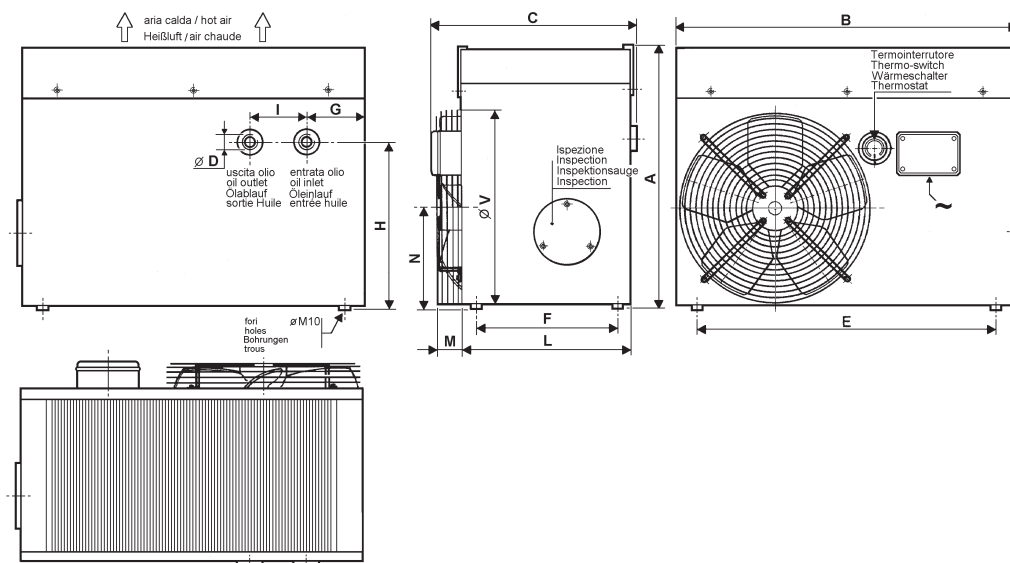

	A	B	C	D	E	F	G	H	I	L	M	N	V
CR1	410	490	310	1/2" G	415	190	90	263	80	245	10	158	250
CR2	463	600	365	3/4" G	530	250	100	296	100	300	45	181	300
CR3	575	760	465	IN = 1" G OUT = 3/4" G	690	350	100	408	100	400	45	228	400

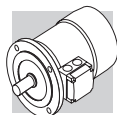
MOTORI ELETTRICI
ELECTRIC MOTORS
ELEKTROMOTOREN
**MOTEURS
ELECTRIQUES**
**M1 - SIMBOLOGIA E
UNITÀ DI MISURA**
**M1 - SYMBOLS AND UNITS
OF MEASUREMENT**
**M1 - SYMBOLE UND
MAßEINHEITEN**
**M1 - SYMBOLES ET UNITES
DE MESURE**

Simb. Symb.	U.m. Einheit	Descrizione	Description	Beschreibung	Description
$\cos\varphi$	–	Fattore di potenza	Power factor	Leistungsfaktor	Facteur de puissance
η	–	Rendimento	Efficiency	Wirkungsgrad	Rendement
f_m	–	Fattore correttivo della potenza	Power adjusting factor	Leistungskorrekturfaktor	Facteur de correction de la puissance
I	–	Rapporto di intermittenza	Cyclic duration factor	Relative Einschaltdauer	Rapport d'intermittence
I_N	[A]	Corrente nominale	Rated current	Nennstrom	Courant nominal
I_S	[A]	Corrente di spunto	Locked rotor current	Kurzschlußstrom	Courant de démarrage
J_C	[Kgm ²]	Momento di inerzia del carico	Load moment of inertia	Massenträgheitsmoment der externen Massen	Moment d'inertie de la charge
J_M	[Kgm ²]	Momento di inerzia motore	Moment of inertia	Trägheitsmoment	Moment d'inertie du moteur
K_C	–	Fattore di coppia	Torque factor	Drehmomentfaktor	Facteur de couple
K_d	–	Fattore di carico	Load factor	Lastfaktor	Facteur de charge
K_J	–	Fattore di inerzia	Inertia factor	Trägheitsfaktor	Facteur d'inertie
M_A	[Nm]	Coppia accelerante media	Mean breakaway torque	Losbrechmoment	Couple d'accélération moyen
M_B	[Nm]	Coppia frenante	Brake torque	Bremsemoment	Couple du frein
M_N	[Nm]	Coppia nominale	Rated torque	Nennmoment	Couple nominal
M_L	[Nm]	Coppia resistente media	Counter-torque during acceleration	Lastmoment	Couple résistant moyen
M_S	[Nm]	Coppia di spunto	Starting torque	Startmoment	Couple de démarrage
n	[min ⁻¹]	Velocità nominale	Rated speed	Nenndrehzahl	Vitesse nominale
P_B	[W]	Potenza assorbita dal freno a 20°C	Power drawn by the brake at 20°C	Leistungsaufnahme der Bremse bei 20°C	Puissance absorbée par le frein à 20°C
P_n	[kW]	Potenza nominale	Motor rated power	Nennleistung	Puissance nominale
P_r	[kW]	Potenza richiesta	Required power	Benötigte Leistung	Puissance nécessaire
t_1	[ms]	Ritardo di sblocco del freno con alimentatore a semionda	Brake response time with one-way rectifier	Ansprechzeit Bremse mit Einweg-Gleichrichter	Temps de déblocage du frein avec alimentation à demi-onde
t_{1s}	[ms]	Tempo di sblocco del freno con alimentatore a controllo elettronico	Brake response time with electronic-controlled rectifier	Ansprechzeit Bremse mit elektronisch gesteuertem Gleichrichter	Temps de déblocage du frein avec alimentation à contrôle électronique
t_2	[ms]	Ritardo di frenatura con disgiunzione lato c.a.	Brake reaction time with a.c. disconnect	Einfallzeit Bremse bei Unterbrechung der Stromversorgung WS	Retard de freinage avec coupure coté c.a.
t_{2c}	[ms]	Ritardo di frenatura con disgiunzione circuito c.a. e c.c.	Brake reaction time with a.c. and d.c. disconnect	Einfallzeit Bremse bei Unterbrechung der Stromversorgung WS und GS	Retard de freinage avec coupure coté c.a. et c.c.
t_a	[°C]	Temperatura ambiente	Ambient temperature	Umgebungstemperatur	Température ambiante
t_f	[min]	Tempo di funzionamento a carico costante	Work time at constant load	Betriebsdauer unter Nennbelastung	Temps de fonctionnement à charge constante
t_r	[min]	Tempo di riposo	Rest time	Aussetzzeit	Temps de repos
W	[J]	Lavoro di frenatura accumulato tra due regolazioni del traferro	Braking work between service interval	Bremsenergie zwischen zwei Einstellungen	Energie de freinage accumulée entre deux réglages de l'entrefer
W_{max}	[J]	Energia massima per singola frenatura	Maximum brake work for each braking	Max. Bremsarbeit pro Bremsvorgang	Energie maxi par freinage
Z	[1/h]	N° di avviamenti ammissibili, a carico	Permissible starting frequency, loaded	Schalhäufigkeit Nennbetrieb	Nombre de démarrages admissibles en charge
Z_0	[1/h]	N° di avviamenti ammissibili a vuoto (I = 50%)	Max. permissible unloaded starting frequency (I = 50%)	Max. Schalhäufigkeit im Leerlauf (relative Einschalt-dauer I = 50%)	Nombre de démarrages admissible à vide (I = 50%)

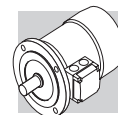

M2 - CARATTERISTICHE GENERALI

Programma di produzione

I motori elettrici asincroni trifase del programma di produzione della BONFIGLIOLI RIDUTTORI sono previsti nelle forme costruttive base IMB5, IMB14 e loro derivate con le seguenti polarità: 2, 4, 6, 2/4, 2/6, 2/8, 2/12. Nel presente catalogo sono evidenziate inoltre, le caratteristiche tecniche dei motori in versione integrata, tipo M.

Normative

I motori descritti in questo catalogo sono costruiti in accordo alle Norme ed unificazioni applicabili evidenziate nella tabella seguente.

M2 - GENERAL CHARACTERISTICS

Production range

The asynchronous three-phase electric motors of BONFIGLIOLI RIDUTTORI's production, are available in basic designs IMB5 and IMB14 and derived versions, with the following polarities: 2, 4, 6, 2/4, 2/6, 2/8, 2/12. The technical characteristics of compact motors, M type, are also supplied in this manual.

Standards

The motors described in this catalogue are manufactured to the applicable standards shown in the following table.

M2 - ALLGEMEINE EIGENSCHAFTEN

Produktprogramm

Die Dreiphasen-Asynchronmotoren aus dem Produktprogramm von BONFIGLIOLI RIDUTTORI gibt es in den Grundbauformen IMB5, IMB14 und deren Ableitungen mit folgenden Polzahlen: 2, 4, 6, 2/4, 2/6, 2/8 und 2/12. Im vorliegenden Katalog sind außerdem die technischen Eigenschaften der Motoren in Kompaktausführung hervorgehoben.

Normen

Die in diesem Katalog beschriebenen Motoren sind in Übereinstimmung mit den in der folgenden Tabelle angegebenen einschlägigen Normen und Vereinheitlichungsrichtlinien konstruiert worden.

M2 - CARACTERISTIQUES GENERALES

Programme de production

Les moteurs électriques asynchrones triphasés du programme de production de BONFIGLIOLI RIDUTTORI sont prévus dans les formes de construction de base IMB5, IMB14 et leur dérivés avec les polarités suivantes: 2, 4, 6, 2/4, 2/6, 2/8, 2/12. Dans le présent catalogue sont également mises en évidence les caractéristiques techniques des moteurs en version compacte, type M.

Réglementations

Les moteurs décrits dans ce catalogue sont construits en accord avec les Normes et standardisations applicables mises en évidence dans le tableau ci-dessous.

(A26)

Titolo / Title / Titel / Titre	CEI	IEC
Prescrizioni generali per macchine elettriche rotanti <i>General requirements for rotating electrical machines</i> Allgemeine Vorschriften für umlaufende elektrische Maschinen <i>Prescriptions générales pour machines électriques tournantes</i>	CEI EN 60034-1	IEC 60034-1
Marcatura dei terminali e senso di rotazione per macchine elettriche rotanti <i>Terminal markings and direction of rotation of rotating machines</i> Kennzeichnung der Anschlußklemmen und Drehrichtung von umlaufenden elektrischen Maschinen <i>Définitions des bornes et sens de rotation pour machines électriques tournantes</i>	CEI 2-8	IEC 60034-8
Metodi di raffreddamento delle macchine elettriche <i>Methods of cooling for electrical machines</i> Verfahren zur Kühlung von elektrischen Maschinen <i>Méthodes de refroidissement des machines électriques</i>	CEI EN 60034-6	IEC 60034-6
Dimensioni e potenze nominali per macchine elettriche rotanti <i>Dimensions and output ratings for rotating electrical machines</i> Auslegung der Nennleistung von umlaufenden elektrischen Maschinen <i>Dimensions, puissances nominales pour machines électriques tournantes</i>	EN 50347	IEC 60072
Classificazione dei gradi di protezione delle macchine elettriche rotanti <i>Classification of degree of protection by enclosures for rotating machines</i> Klassifizierung der Schutzart von umlaufenden elektrischen Maschinen <i>Classification des degrés de protection des machines électriques tournantes</i>	CEI EN 60034-5	IEC 60034-5
Limiti di rumorosità <i>Noise limits</i> Geräuschgrenzwerte <i>Limites de bruit</i>	CEI EN 60034-9	IEC 60034-9
Sigle di designazione delle forme costruttive e dei tipi di installazione <i>Classification of type of construction and mounting arrangements</i> Abkürzungen zur Kennzeichnung der Bauform und der Einbaulagen <i>Sigles de dénomination des formes de construction et des types d'installation</i>	CEI EN 60034-7	IEC 60034-7
Tensione nominale per i sistemi di distribuzione pubblica dell'energia elettrica a bassa tensione <i>Rated voltage for low voltage mains power</i> Nennspannung für öffentliche NS-Stromverteilungssysteme <i>Tension nominale pour les systèmes de distribution publique de l'énergie électrique en basse tension</i>	CEI 8-6	IEC 60038
Grado di vibrazione delle macchine elettriche <i>Vibration level of electric machines</i> Schwingstärke bei elektrischen Maschinen <i>Degré de vibration des machines électriques</i>	CEI EN 60034-14	IEC 60034-14

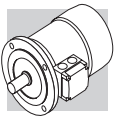

I motori corrispondono inoltre alle Norme straniere adeguate alle IEC 60034-1 e qui riportate.

The motors also comply with foreign standards adapted to IEC 60034-1 as shown here below.

Die Motoren entsprechen außerdem den an die IEC-Norm 60034-1 angepaßten ausländischen Normen, die in der folgenden Tabelle genannt werden.

En outre, les moteurs correspondent aux Normes étrangères adaptées aux IEC 60034-1 indiquées dans le tableau ci-dessous.

(A27)

DIN VDE 0530	Germania	Germany	Deutschland	Allemagne
BS5000 / BS4999	Gran Bretagna	Great Britain	Großbritannien	Grande Bretagne
AS 1359	Australia	Australia	Australien	Australie
NBNC 51 - 101	Belgio	Belgium	Belgien	Belgique
NEK - IEC 34	Norvegia	Norway	Norwegen	Norvège
NF C 51	Francia	France	Frankreich	France
OEVE M 10	Austria	Austria	Österreich	Autriche
SEV 3009	Svizzera	Switzerland	Schweiz	Suisse
NEN 3173	Paesi Bassi	Netherlands	Niederlande	Pays Bas
SS 426 01 01	Svezia	Sweden	Schweden	Suède

CUS

MOTORI PER USA E CANADA

MOTORS FOR USA AND CANADA

MOTOREN FÜR DIE USA UND KANADA

MOTEURS POUR ETATS-UNIS ET CANADA

I motori BN ed M sono disponibili in esecuzione NEMA Design C (per le caratteristiche elettriche), certificata in conformità alle norme CSA (Canadian Standard) C22.2 N° 100 e UL (Underwriters Laboratory) UL 1004 con targhetta riportante entrambi i marchi sotto illustrati, specificare in questo caso l'opzione CUS.

BN and M motors are available in NEMA Design C configuration (concerning electrical characteristics), certified to CSA (Canadian standard) C22.2 No. 100 and UL (Underwriters Laboratory) UL 1004. By specifying the option CUS the name plate is marked with both symbols shown here below.

Die BN/M-Motoren sind in der Ausführung NEMA, Design C (aufgrund der elektrischen Eigenschaften), den Normen CSA (Canadian Standard) C22.2 Nr 100 und UL (Underwriters Laboratory) UL 1004 gemäß zertifiziert. Durch Spezifizieren der Option CUS wird das Typenschild mit den nachstehend aufgeführten Symbolen gekennzeichnet.

Les moteurs BN et M sont disponibles en exécution NEMA Design C (pour les caractéristiques électriques), certifiée conforme aux normes CSA (Canadian Standard) C22.2 N°100 et UL (Underwriters Laboratory) UL 1004 avec une plaque signalétique indiquant chacun des symboles ci-dessous, dans ce cas, spécifier l'option CUS.



Le tensioni delle reti di distribuzione americane e le corrispondenti tensioni nominali da specificare per il motore sono indicate nella tabella seguente:

US power mains voltages and the corresponding rated voltages to be specified for the motor are indicated in the following table:

Die Spannungen der amerikanischen Verteilernetze und die entsprechenden tens-Nennspannungen, die bei den Motoren angegeben werden müssen, können der folgenden Tabelle entnommen werden:

Les tensions des réseaux de distribution américains ainsi que les tensions nominales à spécifier pour le moteur sont indiquées dans le tableau suivant :

(A28)

Frequenza / Frequency Frequenz / Fréquence	Tensione di rete / Mains voltage Netzspannung / Tension de réseau	V _{mot}
60 Hz	208 V	200 V
	240 V	230 V
	480 V	460 V
	600 V	575 V

I motori dotati di collegamento YY/Y (es. 230/460-60; 220/440-60) presentano di serie una morsettiera a 9 terminali.

Motors with YY/Y connection (e.g. 230/460-60; 220/440-60) feature, as standard, a 9-stud terminal board. For same executions, as well as for 575V-60Hz supply, the nominal rating is coincident with the correspondent 50Hz rating.

Motoren mit YY/Y-Anschluss (z.B. 230/460-60; 220/440-60) sind standardmäßig mit 9 Pins auf dem Klemmbrett ausgeführt. Für gleiche Ausführungen, ebenso wie für 575V-60Hz, die Nennleistung ist gleich mit der entsprechenden 50 Hz-Leistung. Für Bremsmotoren mit Gleichstrombremse vom Typ BN_FD erfolgt die Versorgung des Gleichrichters über den Motorklemmenkasten mit einer Spannung von 230V (einphasiger Wechselstrom). Bei Bremsmotoren stellt sich die **Versorgung der Bremse** wie folgt dar:

Les moteurs avec connexion YY/Y (ex. 230/460-60; 220/440-60) présentent, en standard, une plaque à borne avec 9 bornes. Pour les memes executions, et aussi pour l'alimentation 575V-60Hz, la puissance de plaque correspond à celle normalisé à 50Hz.

Per le stesse esecuzioni, e inoltre per l'alimentazione 575V-60Hz, la potenza di targa corrisponde a quella normalizzata a 50Hz.

For DC brake motors type BN_FD, the rectifier is connected to a single-phase 230 VAC supply voltage in the motor terminal box.

Per i motori autofrenanti con freno in c.c. tipo BN_FD l'alimentazione del raddrizzatore è da morsettiera motore con tensione 230V a.c. monofase.

Per i motori autofrenanti l'alimentazione del freno è così predisposta:

Brake power supply for brake motors is as follows:

Pour les moteurs frein avec frein en c.c. type BN_FD, l'alimentation du redresseur provient de la boîte à bornes moteur avec une tension 230V c.a. monophasée. Pour les moteurs frein l'alimentation du frein est la suivante :

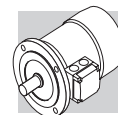

BN_FD M_FD	BN_FA ; BN_BA M_FA	Specificare / Specify Bitte angeben / Spécifier
Da morsettiera motore 1~230V c.a. <i>Wired to terminal box 1~230V a.c.</i> Vom Motorklemmenkasten 1~230V W.S. <i>Depuis boîte à bornes moteur 1~230V c.a.</i>	Alimentazione separata / <i>Separate power supply</i> Fremdversorgung / <i>Alimentation séparée</i> 230V Δ - 60Hz	230SA
	Alimentazione separata / <i>Separate power supply</i> Fremdversorgung / <i>Alimentation séparée</i> 460V Y - 60Hz	460SA

L'opzione CUS non è applicabile ai motori dotati di servoventilazione.

The option CUS does not apply to servo-ventilated motors.

Die CUS-Option ist für die Fremdlüftermotoren nicht anwendbar.

L'option CUS n'est pas applicable aux moteurs doués de ventilation forcée.

Direttive CEE 73/23 (LVD) e CEE 89/336 (EMC)

I motori delle serie BN ed M sono conformi ai requisiti delle Direttive CEE 73/23 (Direttiva Bassa Tensione) e CEE 89/336 (Direttiva Compatibilità Elettromagnetica), e riportano in targa la marcatura CE.

Per quanto riguarda la Direttiva EMC, la costruzione è in accordo alle Norme CEI EN 60034-1 sez. 12, EN 50081, EN 50082.

I motori con freno in c.c. tipo FD, se corredati dell'opportuno filtro capacitivo in ingresso al raddrizzatore (opzione CF), rientrano nei limiti di emissione previsti dalla Norma EN 50081-1 "Compatibilità elettromagnetica - Norma Generica sull'emissione - Parte 1: Ambienti residenziali, commerciali e dell'industria leggera". I motori soddisfano inoltre le prescrizioni della Norma CEI EN 60204-1 "Equipaggiamento elettrico delle macchine".

È responsabilità del costruttore o dell'assemblatore dell'apparecchiatura che incorpora i motori come componenti garantire la sicurezza e la conformità alle direttive del prodotto finale.

Directives 73/23/EEC (LVD) and 89/336/EEC (EMC)

BN motors meet the requirements of Directives 73/23/EEC (Low Voltage Directive) and 89/336/EEC (Electromagnetic Compatibility Directive) and their name plates bear the CE mark.

As for the EMC Directive, construction is in accordance with standards CEI EN 60034-1 Sect. 12, EN 50081, EN50082.

Motors with FD brakes, when fitted with the suitable capacitive filter at rectifier input (option CF), meet the emission limits required by Standard EN 50081-1 "Electromagnetic compatibility - Generic Emission Standard - Part 1: Residential, commercial and light industrial environment".

Motors also meet the requirements of standard CEI EN 60204-1 "Electrical equipment of machines".

The responsibility for final product safety and compliance with applicable directives rests with the manufacturer or the assembler who incorporate the motors as component parts.

Richtlinien EWG 73/23 (LVD) und EWG 89/336 (EMC)

Die Motoren der Serie BN entsprechen den Anforderungen der Richtlinien EWG 73/23 (Richtlinie - Niederspannung) und CEE 89/336 (Richtlinie - elektromagnetische Kompatibilität) und sind mit dem CE-Zeichen ausgestattet.

Im Hinblick auf die Richtlinie EMC entspricht die Konstruktion den Normen CEI EN 60034-1, Abschn. 12, EN 50081, EN 50082.

Die Motoren mit dem Bremstyp FD fallen, falls mit dem entsprechenden kapazitiven Filter am Eingang des Gleichrichters ausgestattet (Option CF), unter die Emissionsgrenzwerte, die von der Norm EN 50081-1 "Elektromagnetische Kompatibilität - Allgemeine Norm für Emissionen - Teil 1: Wohngebiete, Handels- und Leichtindustriezonen" vorgesehen werden. Die Motoren entsprechen darüber hinaus den von der Norm CEI EN 60204-1 "Elektrische Maschinenausrüstung" gegebenen Vorschriften.

Es liegt in der Verantwortung des Herstellers oder es Monteurs der Ausrüstung, in der die Motoren als Komponenten montiert werden, die Sicherheit und die Übereinstimmung mit den Richtlinien des Endprodukts zu gewährleisten.

Direttive CEE 73/23 (LVD) et CEE 89/336 (EMC)

Les moteurs de la série BN sont conformes aux conditions requises par les Directives CEE 73/23 (Directive Basse Tension) et CEE 89/336 (Directive Compatibilité Electromagnétique), et le marquage CE est indiqué sur la plaque signalétique.

En ce qui concerne la Directive EMC, la fabrication répond aux Normes CEI EN 60034-1 Sect. 12, EN 50081, EN 50082.

Les moteurs avec frein FD, s'ils sont équipés du frein capacitif approprié en entrée du redresseur (option CF), rentrent dans les limites d'émission prévues par la Norme EN 50081-1 "Compatibilité électromagnétique - Norme Générique sur l'émission - Partie 1 : Milieux résidentiels, commerciaux et de l'industrie légère".

Les moteurs répondent aussi aux prescriptions de la Norme CEI EN 60204-1 "Equipement électrique des machines".

Le fabricant ou le monteur de la machine qui comprend les moteurs comme composant est responsable et doit se charger de garantir la sécurité et la conformité aux directives du produit final.

Rendimento - Accordo CEMEP

Con l'obiettivo di ridurre significativamente il consumo europeo di energia elettrica mediante la sensibilizzazione degli utenti all'uso di motori maggiormente efficienti, la Commissione Europea per l'Energia e il CEMEP hanno concordato le condizioni ricorrenti per la classificazione dei motori elettrici in classi di rendimento denominate, in senso decrescente, **eff1**, **eff2** ed **eff3**.

Oggetto di questo accordo sono solamente i motori trifase standard in c.a. a 2 e 4 poli, costruzione chiusa con rotore a gabbia di scoiattolo, ventilazione esterna e potenza all'albero compresa fra 1,1 e 90 kW, alimentazione a 400V - 50 Hz in servizio continuo S1.

È facoltà dei costruttori di motori elettrici decidere di classificare volontariamente i propri prodotti in una delle tre classi di rendimento sopra citate. In questo caso essi devono apporre sulla targa il marchio relativo alla classe di rendimento applicabile ed inserire, fra i dati tecnici, i valori

Efficiency - the CEMEP agreement

*CEMEP, the European Committee of Manufacturers of Electrical Machines and Power Electronics hopes to reduce electrical energy consumption in Europe by informing users of the efficiency of electrical motors. As a contribution in this direction, CEMEP has recently published an agreement stating the specifications for electric motor energy efficiency classes **eff1**, **eff2** and **eff3** (listed in order of decreasing efficiency).*

The CEMEP agreement covers only standard, 2 and 4 pole, three phase, AC motors, of closed rotor and squirrel cage construction, with external ventilation and rated power at the output shaft of 1.1 to 90 kW, for use with a 400V - 50 Hz power supply under S1 continuous duty conditions.

It is left up to individual electric motor manufacturers to classify their products in one of the three above classes. If they decide to do so, they must apply the relevant efficiency mark to the motor and include, together with all the

Wirkungsgrad - die CEMEP Vereinbarung

CEMEP, der europäische Herstellerverband von elektrischen Maschinen und Leistungs-Elektronik hofft, den elektrischen Energieverbrauch in Europa, durch Informationen über die Wirkungsgrade von elektrischen Motoren an die Benutzer, zu reduzieren. Als Beitrag in dieser Richtung, hat die CEMEP vor kurzem eine Vereinbarung veröffentlicht, die die Energie-Effizienz-Klassen **eff1**, **eff2** und **eff3** für Elektromotoren spezifiziert. (Aufgelistet nach abnehmendem Wirkungsgrad).

Die CEMEP Vereinbarung beinhaltet nur 2 und 4 polige Drehstrommotoren mit geschlossenem Rotor als Kurzschlussläufer, integrierem Lüfter, Nennleistungen an der Abtriebswelle von 1.1 - 90 kW, mit einer Energieversorgung von 400V - 50Hz und der Betriebsart S1 (Dauerbetrieb).

Es bleibt den einzelnen Elektromotoren Herstellern überlassen, ihre Produkte nach einer der drei oben benannten Effizienz-Klassen zu klassifizieren. Wenn sie sich dazu entscheiden, müssen sie die relevante Markierung auf dem Motor anbringen und zusammen mit allen anderen relevanten techni-

Rendement - L'accord CEMEP

*La Commission Européenne sur l'Energie et le CEMEP (European Committee of Manufacturers of Electrical Machines and Power Electronics), espère réduire de façon sensible la consommation européenne d'énergie électrique à travers l'information sur l'efficience des moteurs électriques. Pour ce faire, ils ont fixés une classification des moteurs électriques en « classes de rendement » appelée, en sens décroissant d'efficience : **eff1**, **eff2** et **eff3**.*

Font partie de cet accord seulement les moteurs triphasés standard en c.a. à 2 et 4 pôles, de type fermé et rotor à cage, ventilation extérieure et puissance à l'arbre comprise entre 1,1 et 90 kW, alimentation à 400V - 50 Hz en service continue S1.

C'est au choix de chaque constructeur de moteurs électriques de décider de classer ces produits dans une des trois classes de rendement ci-dessus. Dans ce cas, le constructeur doit faire apparaître le logo de la classe de rendement sur la plaque marque

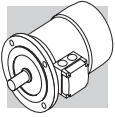

di rendimento a pieno carico ed a $\frac{3}{4}$ del carico nominale.

I motori Bonfiglioli ricompresi nell'oggetto di questo accordo sono conformi alla classe di rendimento **eff2** e sono pertanto chiaramente identificati in targa tramite il logo sotto riportato:

other relevant technical specifications, the measured efficiency figures for full rated load and $\frac{3}{4}$ rated load.

*Under the terms of this agreement, Bonfiglioli's electric motors conform to efficiency class **eff2** and are clearly identified as such by the following mark on the data plate:*



schon Einzelheiten, die gemessenen Wirkungsgradangaben bei Voll- und Dreiviertellast ausweisen. Unter den Bedingungen dieser Vereinbarung entsprechen die elektrischen Motoren von Bonfiglioli der Effizienz-Klasse **eff2** und werden als solche durch die folgende Markierung auf dem Typenschild deutlich gekennzeichnet:

et introduire, dans les caractéristiques techniques, les valeurs de rendement à pleine charge et à $\frac{3}{4}$ de la charge nominale.

*Le moteurs Bonfiglioli concernées dans cet accord, sont conformes à la classe de rendement **eff2** et de conséquence ils présentent, sur la plaque marque, le logo suivant :*

Tolleranze

Secondo le Norme sono ammesse le tolleranze indicate nella tabella seguente sulle grandezze garantite.

Tolerances

As per the Norms applicable the tolerances here below apply to the following quantities.

Toleranzen

Die Normen lassen die in folgenden Tabelle genannten Toleranzen bei den garantierten Größen zu.

Tolérances

Selon les Normes, les tolérances indiquées dans le tableau ci-dessous sont admises sur les tailles garanties.

(A29)

-0.15 (1 - η) P \leq 50kW	Rendimento	<i>Efficiency</i>	Wirkungsgrad	<i>Rendement</i>
$-(1 - \cos\phi)/6$ min 0.02 max 0.07	Fattore di potenza	<i>Power factor</i>	Leistungsfaktor	<i>Facteur de puissance</i>
$\pm 20\%$ *	Scorrimento	<i>Slip</i>	Schlupf	<i>Glissement</i>
+20%	Corrente a rotore bloccato	<i>Locked rotor current</i>	Strom bei blockiertem Läufer	<i>Courant à rotor bloqué</i>
-15% +25%	Coppia a rotore bloccato	<i>Locked rotor torque</i>	Drehmoment bei blockiertem Läufer	<i>Couple à rotor bloqué</i>
-10%	Coppia max	<i>Max. torque</i>	Max. Drehmoment	<i>Couple max</i>

* \pm 30% per motori con Pn < 1 kW

* \pm 30% for motors with Pn < 1 kW

* \pm 30% für Motoren mit Pn < 1 kW

* \pm 30% pour moteurs avec Pn < 1 kW

M3 - CARATTERISTICHE MECCANICHE

Forme costruttive

I motori serie BN sono previsti nelle forme costruttive indicate in tabella (A30) secondo le Norme CEI EN 60034-14.

Le forme costruttive sono le seguenti:

IM B5 (base)
IM V1, IM V3 (derivate)

IM B14 (base)
IM V18, IM V19 (derivate)

I motori in forma costruttiva IM B5 possono essere installati nelle posizioni IM V1 e IM V3; i motori in forma costruttiva IM B14 possono essere installati nelle posizioni IM V18 e IM V19.

In questi casi, sulla targa del motore sarà indicata la forma costruttiva base IM B5 o IM B14. Nelle forme costruttive dove il motore assume una posizione verticale con albero in basso, si consiglia di richiedere l'esecuzione con tettuccio parapigioggia (da prevedere sempre nel caso di motori autofrenanti). Tale esecuzione, pressente nelle opzioni, va richiesta espressamente in fase di ordine in quanto non è prevista nella versione base.

M3 - MECHANICAL FEATURES

Versions

IEC-normalised BN motors are available in the design versions indicated in table (A30) as per Standards CEI EN 60034-14.

Mounting versions are:

IM B5 (basic)
IM V1, IM V3 (derived)

IM B14 (basic)
IM V18, IM V19 (derived)

IM B5 design motors can be installed in positions IM V1 and IM V3; IM B14 design motors can be installed in positions IM V18 and IM V19.

In such cases, the basic design IM B5 or IM B14 is indicated on the motor name plate.

In design versions with a vertically located motor and shaft downwards, it is recommended to request the drip cover (always necessary for brake motors). This facility, included in the option list should be specified when ordering as it does not come as a standard device.

M3 - MECHANISCHE EIGENSCHAFTEN

Bauformen

Die Motoren der Serie BN weisen die in der Abbildung (A30) angegebene Bauform gemäß den Normen CEI EN 60034-14 auf.

Die Bauformen sind:

IM B5 (Grundmodell)
IM V1, IM V3 (Ableitungen)

IM B14 (Grundmodell)
IM V18, IM V19 (Ableitungen)

Die Motoren mit der Bauform IM B5 können mit den Einbaulagen IM V1 und IM V3 eingebaut werden; die Motoren mit der Bauform IM B14 können mit den Einbaulagen IM V18 und IM V19 eingebaut werden.

In diesen Fällen ist auf dem Leistungsschild des Motors die Bauform IM B5 oder IM B 14 angegeben.

Bei Bauformen mit vertikaler Lage des Motors und nach unten gerichteter Welle wird die Ausführung mit Regenschutzabdeckung empfohlen (bei Bremsmotoren stets vorzusehen). Dieses wahlweise Zubehör muß ausdrücklich zum Zeitpunkt der Bestellung verlangt werden, da es bei der Grundausführung nicht vorgesehen ist.

M3 - CARACTERISTIQUES MECANIKES

Formes de construction

Les moteurs série BN sont prévus dans les formes de construction indiquées sur le tableau (A30) selon les normes CEI EN 60034-14.

Les formes de construction sont les suivantes:

IM B5 (base)
IM V1, IM V3 (dérivées)

IM B14 (base)
IM V18, IM V19 (dérivées)

Les moteurs en forme de construction IM B5 peuvent être installés dans les positions IM V1 et IM V3; les moteurs en forme de construction IM B14 peuvent être installés dans les positions IM V18 et IM V19.

Dans ces cas, la forme de construction base IM B5 ou IM B14 sera indiquée sur la plaque du moteur. Dans les formes de construction où le moteur présente une position verticale avec arbre vers le bas, nous conseillons de demander l'exécution avec capot de protection contre la pluie (à prévoir toujours dans le cas de moteurs freins). Cette exécution, prévue dans les options, doit être expressément demandée en phase de commande étant donné qu'elle n'est pas prévue dans la version de base.

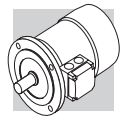

(A30)

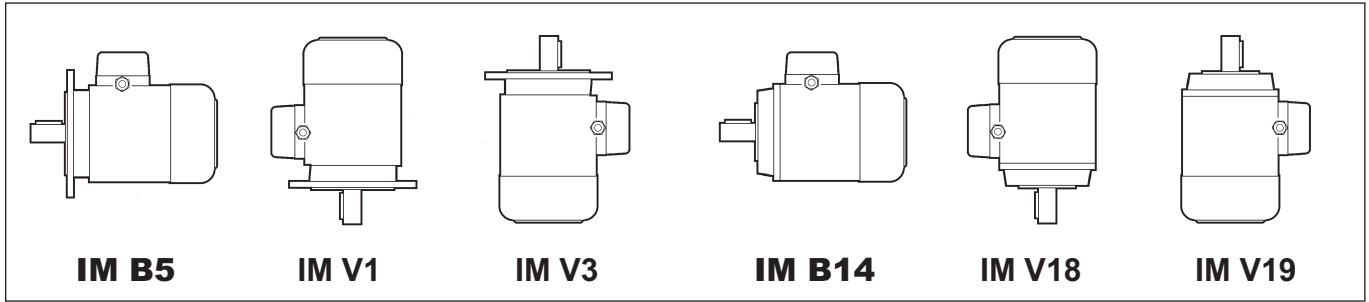

I motori in forma flangiata possono essere forniti con dimensioni di accoppiamento ridotte, come riportato in tabella (A31) - esecuzioni **B5R**, **B14R**.

Flanged motors can be supplied with a reduced mounting interface, as shown in chart (A31) below.

Die Motoren in der Auslegung mit Flansch können mit reduzierten Passmassen gemäß Tabelle (A31) - Versionen **B5R**, **B14R** geliefert werden.

*Les moteurs avec forme à bride peuvent être fournis avec des tailles d'accouplement réduites, comme indiqué dans le tableau (A31) - exécutions **B5R**, **B14R**.*

(A31)

	BN 71	BN 80	BN 90	BN 100	BN 112	BN 132
	DxE - Ø					
B5R ⁽¹⁾	11x23 - 140	14x30 - 160	19x40 - 200	24x50 - 200	24x50 - 200	28x60 - 250
B14R ⁽²⁾	11x23 - 90	14x30 - 105	19x40 - 120	24x50 - 140	—	—

⁽¹⁾ flangia con fori passanti

⁽¹⁾ flange with through holes

⁽¹⁾ Flansch mit durchgehenden Bohrungen

⁽¹⁾ bride avec orifices passants

⁽²⁾ flangia con fori filettati

⁽²⁾ flange with threaded holes

⁽²⁾ Flansch mit Gewindebohrungen

⁽²⁾ bride avec orifices filetés

IP..

Grado di protezione

La tabella sottostante riassume la disponibilità dei vari gradi di protezione. Indipendentemente dal grado di protezione specificato, per installazione all'aperto i motori devono essere protetti dall'irraggiamento diretto e, nel caso d'installazione con albero rivolto verso il basso, è necessario specificare ulteriormente il tettuccio di protezione contro l'ingresso di acqua e corpi solidi (opzione **RC**).

Degree of protection

*The following chart provides an overview of the degrees of protection available. In addition to the degree of protection specified when ordering, motors to be installed outdoors require protection against direct sunlight and also – when they are to be installed vertically down – a drip cover to prevent the ingress of water and solid particles (option **RC**).*

Schutzart

In der nachstehenden Tabelle werden die jeweils zur Verfügung stehenden Schutzarten zusammengefasst. Unabhängig von der spezifischen Schutzart müssen die im Freien installierten Motoren vor direkten Strahlungen geschützt werden. Im Fall einer senkrechten Montage, in der die Welle nach unten gerichtet ist, sollte darüber hinaus das Schutzdach bestellt werden, das vor dem Eindringen von Wasser und festen Fremdkörpern schützt (Option **RC**).

Degré de protection

*Le tableau ci-dessous résume la disponibilité des différents degrés de protection. Indépendamment du degré de protection spécifié, en cas d'installation en plein air, les moteurs doivent être protégés des rayons directs du soleil et, en cas d'installation avec l'arbre dirigé vers le bas, il est nécessaire de spécifier ultérieurement le capot de protection contre la pénétration de l'eau et des corps solides (option **RC**).*

(A32)

		IP 54	IP 55	IP 56
		IP 54	IP 55	IP 56
BN	M	⊖	standard	
BN_FD BN_FA	M_FD M_FA	standard		⊖
BN_BA	—	⊖	standard	⊖

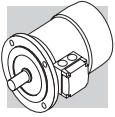

Ventilazione

I motori sono raffreddati mediante ventilazione esterna (IC 411 secondo CEI EN 60034-6) e sono provvisti di ventola radiale in plastica che funziona in entrambi i sensi di rotazione. L'installazione deve assicurare una distanza minima dalla calotta copriventola alla parete in modo da non avere impedimenti all'ingresso aria e permettere la possibilità di eseguire l'opportuna manutenzione del motore e, se previsto, del freno. Su richiesta è possibile prevedere una ventilazione forzata indipendente (opzione U1). Questa soluzione consente di aumentare il fattore di utilizzo del motore nel caso di alimentazione da inverter e funzionamento a giri ridotti.

Senso di rotazione

È possibile il funzionamento in entrambi i sensi di rotazione. Con collegamento dei morsetti U1, V1, W1 alle fasi di linea L1, L2, L3 si ha rotazione oraria vista dal lato accoppiamento, mentre la marcia antioraria si ottiene scambiando fra loro due fasi.

Rumorosità

I valori di rumorosità, rilevati secondo il metodo previsto dalle Norme ISO 1680, sono contenuti entro i livelli massimi previsti dalle Norme CEI EN 60034-9.

Vibrazioni ed equilibratura

Tutti i rotor sono equilibrati con mezza linguetta e rientrano nei limiti di intensità di vibrazione previsti dalle Norme CEI EN 60034-14. Per particolari esigenze di silenziosità potrà essere previsto, a richiesta, un'esecuzione antivibrante in grado ridotto R. La tabella seguente riporta i valori della velocità efficace di vibrazione per equilibratura standard (N) e incrementata (R).

(A33)

Grado di vibrazione Vibration class Schwingungsklasse Degré de vibration	Velocità di rotazione Angular velocity Drehungsgeschwindigkeit Vitesse de rotation n [min ⁻¹]	Limiti della velocità di vibrazione Limits of the vibration velocity Grenzen der Schwingungsgeschwindigkeit Limites de la vitesse de vibration [mm/s]	
		BN 56...BN 132 M05...M4	BN 160MR...BN 200 M5
N	600 ≤ n ≤ 3600	1.8	2.8
R	600 ≤ n ≤ 1800	0.71	1.12
	1800 < n ≤ 3600	1.12	1.8

I valori si riferiscono a misure con motore liberamente sospeso e funzionamento a vuoto.

Cooling

The motors are externally ventilated (IC 411 to CEI EN 60034-6) and are equipped with a plastic fan working in both directions. The motors must be installed allowing sufficient space between fan cowling and the nearest wall to ensure free air intake and allow access for maintenance purposes on motor and brake, if supplied. Independent, forced air ventilation (IC 416) can be supplied on request (option U1). This solution enables to increase the motor duty factor when driven by an inverter and operating at reduced speed.

Direction of rotation

Rotation is possible in both directions. If terminals U1, V1, and W1 are connected to line phases L1, L2 and L3, clockwise rotation (looking from drive end) is obtained. For counterclockwise rotation, switch two phases.

Noise

Noise levels, measured using the method prescribed by ISO 1680 Standards, are within the maximum levels specified by Standards CEI EN 60034-9.

Vibrations and balancing

Rotor shafts are balanced with half key fitted and fall within the vibration class N, as per Standard CEI EN 60034-14. If a further reduced noise level is required improved balancing can be optionally requested (class R). Table below shows the value for the vibration velocity for standard (N) and improved (R) balancing.

Values refer to measures with freely suspended motor in unloaded conditions.

Lüftung

Die Motoren sind eigenbelüftet (IC 411 gemäß CEI EN 60034-6) und verfügen über ein Radiallüfterrad aus Kunststoff, das in beiden Drehrichtungen arbeiten kann. Bei der Installation muß sichergestellt werden, daß die Lüfterradabdeckung soweit von der Wand entfernt ist, daß der Luft-eintritt nicht behindert wird, und daß der Motor und (falls vorhanden) die Bremse problemlos gewartet werden können. Auf Wunsch können die Motoren mit Fremdbelüftung geliefert werden (Option U1). Diese Lösung ermöglicht das Motorbetriebsfaktor zu erhöhen, wenn vom Frequenzumrichter gesteuert und zu niedrigen Geschwindigkeit betrieben.

Drehrichtung

Der Betrieb in beiden Drehrichtungen ist möglich. Schließt man die Klemmen U1, V1, W1 an die Phasen L1, L2, L3 an, dreht sich der Motor im Uhrzeigersinn (von der Verbindungsseite her betrachtet); die Drehung im Gegenuhrzeigersinn erhält man, indem man zwei Phasen vertauscht.

Geräuschpegel

Die mit der von der ISO-Norm 1680 vorgesehenen Methoden gemessenen Lärmstärkewerte liegen innerhalb der gemäß den Normen CEI EN 60034-9 zulässigen Höchstgrenzen.

Schwingungen und Ausgleich

Alle Rotoren werden durch einen halben Federkeil ausgeglichen und fallen somit unter die, von den Normen CEI EN 60034-14 vorgesehenen Schwingungsgradgrenzen. Bei besonderen Anforderungen an die Laufruhe kann auf Anfrage eine schwingungsdämpfende Ausführung in der reduzierten Klasse (R) geliefert werden. Die folgende Tabelle führt die Werte der Ist-Schwingungsgeschwindigkeit für einen normalen (N) und verbesserten (R) Ausgleich auf.

Die Werte beziehen sich auf die Abmessungen mit stehendem Motor, ohne Getriebe und Leerlauf.

Ventilation

Les moteurs sont refroidis à l'aide d'une ventilation extérieure (IC 411 selon CEI EN 60034-6) et sont dotés d'un ventilateur à ailettes en plastique qui fonctionne dans les deux sens de rotation. L'installation doit assurer une distance minimum entre le capot de protection du ventilateur et la paroi afin de permettre une bonne circulation de l'air et rendre plus aisé l'entretien du moteur et si prévu, du frein. Sur demande, il est possible de prévoir une ventilation forcée indépendante (option U1). Cette solution permet d'augmenter le facteur d'utilisation du moteur en cas d'alimentation, via un variateur de fréquence, et pour un fonctionnement à faible vitesse.

Sens de rotation

Un fonctionnement dans les deux sens de rotation est possible. Avec raccordement des bornes U1, V1, W1 aux phases de ligne L1, L2, L3, on a la rotation dans le sens des aiguilles d'une montre vue du côté liaison alors que le sens inverse s'obtient en intervertissant les deux phases entre elles.

Niveau de bruit

Les valeurs relevées selon la méthode prévue par les normes ISO 1680 sont situées sous les niveaux maximums prévus par les normes CEI EN 60034-9.

Vibrations et équilibrage

Tous les rotors sont équilibrés avec une demi languette et rentrent dans les limites d'intensité de vibration prévues par les Normes CEI EN 60034-14. En cas d'exigences particulière concernant le niveau de bruit, sur demande, il est possible de réaliser une exécution antivibrante, de degré réduit (R). Le tableau ci-dessous indique les valeurs de la vitesse efficace de vibration pour un équilibrage standard (N) et amélioré (R).

Les valeurs se réfèrent à des mesures avec moteur librement suspendu et fonctionnement à vide.

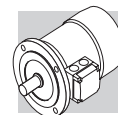

Morsettiera motore

La morsettiera principale è a sei morsetti per collegamento con capicorda. All'interno della scatola è previsto un morsetto per il conduttore di terra.

Le dimensioni dei perni di attacco sono riportate nella tabella seguente.

Nel caso di motori autofrenanti, il raddrizzatore per l'alimentazione del freno è fissato all'interno della scatola e provvisto di adeguati morsetti di collegamento.

Eseguire i collegamenti secondo gli schemi riportati all'interno della scatola coprimorsetti o nei manuali d'uso.

Terminal box

Terminal board features 6 studs for eyelet terminal connection. A ground terminal is also supplied for earthing of the equipment.

Terminals number and type are shown in the following table. Brakemotors house the a.c./d.c. rectifier (factory pre-wired) inside the terminal box.

Wiring instructions are provided either in the box or in the user manual.

Motorklemmenkasten

Die Hauptklemmleiste hat 6 Klemmen für den Anschluß mit Kabelschuhen. Im Innern des Klemmenkasten befindet sich eine Klemme für den Erdleiter.

Die Abmessungen der Ausschüsse sind in der folgenden Tabelle angegeben.

Bei den Bremsmotoren befindet sich auch der mit den erforderlichen Anschlußklemmen ausgestattete Gleichrichter für die Stromversorgung der Bremse im Klemmenkasten.

Die Anschlüsse müssen gemäß den Diagrammen im Klemmkasten oder in den Betriebsanweisungen durchgeführt werden.

Bornier moteur



Le bornier principal prévoit six bornes pour raccordement avec cosses. Dans le boîtier se trouve une borne pour le conducteur de terre.

Les dimensions des axes de fixation sont reportées dans le tableau ci-dessous.

Dans le cas de moteurs freins, le redresseur pour l'alimentation du frein est fixé à l'intérieur du boîtier et est doté de bornes de raccordement.

Effectuer les connexions selon les schémas indiqués à l'intérieur du bornier, ou dans les manuels d'utilisation.

(A34)

		N° terminali No. of terminals Klemmen N° bornes	Filettatura terminali Terminal threads Gewinde Filetage bornes	Sezione max del conduttore Wire max cross section area Max. leiterquerschnitt Section max du conducteur mm ²
BN 56...BN 71	M05, M1	6	M4	2.5
BN 80, BN 90	M2	6	M4	2.5
BN 100...BN 112	M3	6	M5	6
BN 132...BN 160MR	M4	6	M5	6
BN 160M...BN 180M	M5	6	M6	16
BN 180L...BN 200L	—	6	M8	25

Ingresso cavi

Nel rispetto della Norma EN 50262, i fori di ingresso cavi nelle scatole morsettiera presentano filettature metriche della misura indicata nella tabella seguente.

Cable entry

The holes used to bring cables to terminal boxes use metric threads in accordance with standard EN 50262 as indicated in the table here after.



Kabeleingang

Unter Berücksichtigung der Norm EN 50262 verfügen die Kabeleingänge in die Klemmenkästen über metrische Gewinde, deren Maße, der nachstehenden Tabelle entnommen werden können.

Entrée câbles

Dans le respect de la Norme EN 50262, les orifices d'entrée câbles dans les boîtes à bornes présentent des filetages métriques de la taille indiquée dans le tableau ci-dessous.

(A35)

		Ingresso cavi / Cable entry kabeldurchführung / Entrée câbles	Diametro max. cavo allacciabile / Max. cable diameter allowed Max. zulässiger Kabeldurchmesser / Diam. maxi câble [mm]
BN 63	M05	2 x M20 x 1.5	13
BN 71	M1	2 x M25 x 1.5	17
BN 80 - BN 90	M2	2 x M25 x 1.5	17
BN 100	M3	2 x M32 x 1.5	21
		2 x M25 x 1.5	17
BN 112	—	2 x M32 x 1.5 4 x M25 x 1.5	17
BN 132...BN 160MR	M4	4 x M32 x 1.5	21
BN 160M...BN 200L	M5	2 x M40 x 1.5	29

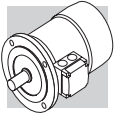

Cuscinetti

I cuscinetti previsti sono del tipo radiale a sfere con lubrificazione permanente precaricati assialmente.

I tipi utilizzati sono indicati nelle tabelle seguenti. La durata nominale a fatica L_{10h} dei cuscinetti, in assenza di carichi esterni applicati è superiore a 40.000 ore, calcolata secondo ISO 281.

DE = lato comando

NDE = lato opposto comando

Bearings

Life lubricated preloaded radial ball bearings are used, types are shown in the chart here under. Calculated endurance lifetime L_{10} , as per ISO 281, in unloaded condition, exceeds 40000 hrs.

DE = drive end

NDE = non drive end

Lager

Bei den Lagern handelt es sich um Radialkugellager mit Dauerschmierung.

Die verwendeten Typen sind in den folgenden Tabellen angegeben.

Die Lebensdauer der Lager bei einer Beanspruchung L_{10h} ist, sofern keine externen Kräfte wirken, über 40.000 Stunden (Berechnung gemäß ISO 281).

DE = Wellenseite

NDE = Lüfterseite

Roulements

Les roulements prévus sont du type radial à billes avec lubrification permanente.

Les types utilisés sont indiqués dans les tableaux ci-dessous.

La résistance à la déformation L_{10h} des roulements en absence de charges extérieures appliquées est supérieure à 40.000 heures calculée selon ISO 281.

DE = sortie arbre

NDE = côté ventilateur

(A36)

	DE	NDE	
	M, M_FD, M_FA	M	M_FD; M_FA
M05	6004 2Z C3	6201 2Z C3	6201 2RS C3
M1	6004 2Z C3	6202 2Z C3	6202 2RS C3
M2	6007 2Z C3	6204 2Z C3	6204 2RS C3
M3	6207 2Z C3	6206 2Z C3	6206 2RS C3
M4	6309 2Z C3	6308 2Z C3	6308 2RS C3
M5	6309 2Z C3	6309 2Z C3	6309 2RS C3

(A37)

	DE	NDE	
	BN, BN_FD, BN_FA, BN_BA	BN, BN_BA	BN_FD; BN_FA
BN 56	6201 2Z C3	6201 2Z C3	—
BN 63	6201 2Z C3	6201 2Z C3	6201 2RS C3
BN 71	6202 2Z C3	6202 2Z C3	6202 2RS C3
BN 80	6204 2Z C3	6204 2Z C3	6204 2RS C3
BN 90	6205 2Z C3	6205 2Z C3	6305 2RS C3
BN 100	6206 2Z C3	6206 2Z C3	6206 2RS C3
BN 112	6306 2Z C3	6306 2Z C3	6306 2RS C3
BN 132	6308 2Z C3	6308 2Z C3	6308 2RS C3
BN 160MR	6309 2Z C3	6308 2Z C3	6308 2RS C3
BN 160M/L	6309 2Z C3	6309 2Z C3	6309 2RS C3
BN 180M	6310 2Z C3	6309 2Z C3	6309 2RS C3
BN 180L	6310 2Z C3	6310 2Z C3	6310 2RS C3
BN 200L	6312 2Z C3	6310 2Z C3	6310 2RS C3

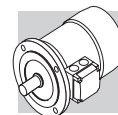

M4 - CARATTERISTICHE ELETTRICHE

Tensione

I motori a una velocità sono previsti nell'esecuzione normale per tensione nominale 230V Δ / 400V Y, 50 Hz con tolleranza di tensione ± 10% (escluso i tipi M3LC4 e M3LC6).

In targa sono indicati oltre alla tensione nominale i campi di funzionamento consentiti, p.e.:

220 - 240V Δ
230 - 415V Y /50 Hz.

In accordo alle Norme CEI EN 60034-1 i motori possono funzionare alle tensioni sopra indicate con tolleranza del ± 5%.

Per funzionamento ai limiti di tolleranza la temperatura può superare di 10 K il limite previsto dalla classe di isolamento adottata.

Ad eccezione dei motori autofrenanti tipo BN_FD in targa vengono indicati anche i valori corrispondenti al funzionamento a 60 Hz (p.e. 460Y, 60 Hz) ed il relativo campo di tensione:

440 - 480VY, 60 Hz.

Per i motori autofrenanti con freno tipo FD le tensioni standard sono:

220V - 240V Δ - 50 Hz
380V - 415V Y - 50 Hz

con tensione di alimentazione freno 230V ± 10%.

La tabella seguente riporta le tensioni previste per i motori.

M4 - ELECTRICAL CHARACTERISTICS

Voltage

Single speed motors are rated for 230/400 V - 50 Hz.

A tolerance of ±10% applies to nominal voltage, with the exception of motors type M3LC4 and M3LC6.

In addition to nominal voltage-frequency values the name plate also shows voltage ranges the motor can operate under, e.g.:

220-240V Δ - 50 Hz
380-415V Y - 50 Hz

As per Norms CEI EN 60034-1 on above voltage values the ±5% tolerance applies.

When operating close to the tolerance limit values the winding temperature can exceed by 10 K the rated temperature for the given insulation class.

With the exception of BN_FD brakemotors, the rated voltage values for operation under 60 Hz mains are also shown on the nameplate, e.g. 460Y-60 Hz along with related tolerance field, e.g. 440-480V Y-60 Hz.

For brakemotors, FD type, rated voltage is:

220-240V Δ - 50 Hz
380-415V Y - 50 Hz

Brake supply is a.c. 230V ±10% single phase.

Chart below shows standard and optional wiring of motors.

M4 - ELEKTRISCHE EIGENSCHAFTEN

Spannung

Die eintourigen Motoren müssen in der Standardausführung mit einer Spannung von 230 V Δ / 400 V Y, 50 Hz mit einer Toleranz von ± 10% gespeist werden (Type M3LC4 und M3LC6 ausgenommen).

Auf dem Schild werden die Nennspannung hinaus, auch die zulässigen Ansprechbereiche angegeben, z.B.:

220-240V Δ
380-415V Y/50 Hz.

Gemäß den Normen CEI EN 60034-1 können die Motoren auf die oben genannten Spannungen mit Toleranzen von ±5% arbeiten.

Bei Betrieb an den Spannungsgrenzen, kann die Temperatur bis zum 10K die für die verwendeten Isolierstoffklasse angegebenen Grenze überschreiten.

Darüber hinaus wird auf den Typenschild die dem 60 Hz-Betrieb entsprechenden Werte angegeben (d.h. 460 Y, 60 Hz) und das entsprechende Spannungsfeld, 440-480VY, 60 Hz.

Für die selbstbremsenden Motoren mit dem Bremstyp FD sind die Standardspannungen folgende:

220V - 240V Δ - 50 Hz
380V - 415V Y - 50 Hz

mit Bremsspannungsversorgung von 230V ± 10%.

Die folgende Tabelle für die Motoren vorgesehenen Spannungen auf.

M4 - CARACTERISTIQUES ELECTRIQUES

Tension

Les moteurs à polarité unique sont prévus dans l'exécution normale pour tension 230V Δ / 400V Y, 50 Hz avec tolérance de tension ± 10% (sauf les types M3LC4 et M3LC6).

Outre la tension nominale, les plages de fonctionnement permises sont indiquées sur la plaquette signalétique, à savoir:

220-240V Δ
380-415V Y/50 Hz.

Selon les normes CEI EN 60034-1 les moteurs peuvent fonctionner aux tension indiquées ci-dessus avec une tolérance de ± 5%.

Pour un fonctionnement à la limite de tolérance, la température peut dépasser les 10K, la limite prévue de la classe d'isolation choisie.

Sur la plaque marque sont de plus indiqués les valeurs correspondantes au fonctionnement en 60 Hz (ex.460Y, 60 Hz) et la relative plage de tension: 440 - 480VY, 60 Hz.

En ce qui concerne les moteurs autofrenants avec frein de type FD, les tensions standard sont les suivantes :

220V - 240V Δ - 50 Hz
380V - 415V Y - 50 Hz

avec tension d'alimentation du frein 230V ± 10%.

La tableau ci-dessous indique les tensions prévues pour les moteurs.

(A38)

		BN M	BN_FD M_FD			BN_FA / BN_BA M_FA		Esecuzione Configuration Version Execution
			$V_{mot} \pm 10\%$ 3~	$V_{mot} \pm 10\%$ 3~	$V_B \pm 10\%$ 1~	$V_{mot} \pm 10\%$ 3~	$V_B \pm 10\%$ 3~	
BN 56 - BN 132	M05...M4	230/400 - 50Hz 460 - 60Hz	230/400V Δ/Y - 50 Hz	230V	230/400V Δ/Y - 50 Hz 460V Y - 60Hz	230/400V Δ/Y - 50 Hz 460V Y - 60Hz	Standard	
BN 100 - BN 132	M3 - M4	400/690 - 50Hz 460 - 60Hz	400/690V Δ/Y - 50 Hz	400V	400/690V Δ/Y - 50 Hz 460V Y - 60Hz	400/690V Δ/Y - 50 Hz 460V Y - 60Hz	A richiesta, senza sovrapprezzo On request at no extra charge Auf Anfrage, ohne Aufpreis Sur demande, sans majoration de prix	

I motori a due velocità 400V/50Hz, sono previsti per tensione nominale standard 400V; tolleranze applicabili secondo CEI EN 60034-1.

Nella tabella seguente sono indicati i vari tipi di collegamenti previsti per i motori in funzione della polarità.

The only rated voltage for motors type 400V/50Hz and all double speed motors is 400V. Applicable tolerances as per CEI EN 60034-1.

The table below shows the wiring options available.

Alle polumschaltbaren Motoren, die Typen 400V/50Hz, sind nicht umschaltbar, standard-mäßig nur für ein Spannung 400V vorgesehen; geltenden Toleranzen gemäß CEI EN 60034-1.

Auf die folgende Tabelle werden die verschiedenen für die Motoren vorgesehenen Anschlußtypen angegeben.

Tous les moteur à deux vitesses, les types 400V/50Hz, sont prévus pour une tension nominale standard de 400V; tolérances applicables selon CEI EN 60034-1.

Dans le tableau ci-dessous sont indiqués les différents types de connexion prévus pour les moteurs.

(A39)

		Poli / Pole / Polig / Pôles	Collegamento avvolgimento / Wiring options Wicklungsanschluß / Connexion du bobinage
		BN 56...BN 200	M05...M5

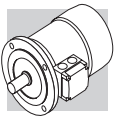

Frequenza

I motori ad una velocità nell'esecuzione standard riportano in targa oltre alle tensioni del funzionamento a 50 Hz il campo di tensione 440 - 480V 60 Hz (escluso motori autofrenanti con freno FD) con potenza aumentata di circa il 20%.
La potenza di targa dei motori a 60Hz corrisponde a quanto riportato nella tabella (A40) seguente:

Frequency

*With the exception of brakemotors, name plate of standard single speed motors shows, besides the 50 Hz voltage ratings, also the rated power output for 60 Hz operation in the 440-480 V range.
Power output is increased by approx 20%.
Rated output power for 60 Hz operation is shown in the following diagram.*



Frequenz

Bei eintourigen Motoren in der Standardausführung wird außer den 50 Hz-Betriebsspannungen auch den Spannungsfeld 440 - 480V 60 Hz angegeben (mit Ausnahme von Bremsmotoren mit Bremsentyp FD) mit einer erhöhten Leistung von ungefähr 20%.
Die Leistung auf das Namensschild von 60 Hz-Motoren entspricht den Daten aus der folgenden Tabelle (A40):

Fréquence

*Les moteurs à une vitesse en exécution standard reportent sur la plaque marque en plus des tension du fonctionnement à 50 Hz la plage de tension 440 - 480V 60 Hz (moteurs freins avec frein FD exclus) avec puissance augmentée de 20% env.
La puissance sur la plaque marque des moteurs à 60 Hz correspond à celle indiquée au tableau (A40) suivant:*

(A40)

		2P	4P	6P
		P _n [kW]		
BN 56A	–	–	0.06	–
BN 56B	M0B	–	0.10	–
BN 63A	M05A	0.21	0.14	0.10
BN 63B	M05B	0.30	0.21	0.14
BN 71A	M05C	0.45	0.30	0.21
BN 71B	M1SD	0.65	0.45	0.30
BN 80A	M1LA	0.90	0.65	0.45
BN 80B	M2SA	1.30	0.90	0.65
BN 90S	M2SB	–	1.30	0.90
BN 90SA	M2SB	1.8	–	–
BN 90L	M3SA	2.5	–	1.3
BN 90LA	M3SA	–	1.8	–
BN 100L	M3LA	3.5	–	–
BN 100LA	M3LA	–	2.5	1.8
BN 100LB	M3LB	4.7	3.5	2.2
BN 112M	M3LB	4.7	4.7	2.5
	M3LC	–	4.7	2.5
BN 132S	M4SA	–	6.5	3.5
BN 132SA	M4SA	6.3	–	–
BN 132SB	M4SB	8.7	–	–
BN 132M	M4LA	11	–	–
BN 132MA	M4LA	–	8.7	4.6
BN 132MB	M4LB	–	11	6.5
BN 160MR	M4LC	12.5	12.5	–
BN 160MB	M5SB	17.5	–	–
BN 160M	M5SA	–	–	8.6
BN 160L	M5S	21.5	17.5	12.6
BN 180M	M5LA	24.5	21.5	–
BN 180L	–	–	25.3	17.5
BN 200L	–	34	34	22

Motori a doppia polarità alimentati a 60 Hz avranno un aumento della potenza nominale, riferita a 50 Hz, pari al 15%.
Qualora sulla targhetta di un motore destinato ad essere alimentato a 60 Hz sia richiesto un valore di potenza nominale pari a quello normalizzato a 50 Hz specificare in designazione l'opzione PN.

*For two-speed motors operated under 60 Hz supply the rated power output is increased by 15% as compared to same motor with 50 Hz supply.
If same IEC-normalised 50 Hz power rating value is desired on name plate of a 60 Hz operated motor specify option PN in the ordering code.
Standard motors wound for 50*

Für polumschaltbare Motoren mit 60 Hz Spannungsversorgung ist die vorgesehene Leistungserhöhung gemäß den Datenblätter von 15%.
Wenn die angefragte 60 Hz-Leistung der normierten 50 Hz-Leistung entspricht, geben bei der Bezeichnung das Option PN an.
Die Motoren mit einer Wicklung für eine Frequenz von 50 Hz

*Pour les moteurs à deux vitesses avec alimentation 60 Hz l'augmentation de puissance prévue per rapport aux valeurs indiquées dans les tableaux techniques, sera de 15%.
Si la puissance requise à 60 Hz correspond à la puissance normalisée à 50 Hz on devra indiquer l'option PN.
Les moteurs bobinés pour fré-*

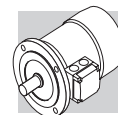

I motori normalmente avvolti per frequenza 50 Hz possono essere usati in reti a 60 Hz con i loro dati che saranno corretti come da tabella seguente.
I freni, se presenti, dovranno sempre essere alimentati alla tensione V_b , riportata in targa.

*Hz supply can be operated under 60 Hz with main data corrected as per chart below:
Brakes, if fitted, must be supplied with the voltage value V_b that is stated on the nameplate.*

können entsprechend den Angaben von Tabelle (A40) an Netze mit 60 Hz angeschlossen werden.
Die Bremse muss, falls angebaut, mit der auf dem Typenschild angegebenen Spannung V_b betrieben werden.

*quence 50 Hz peuvent être utilisés sur réseau à 60 Hz selon les indications du tableau (A40).
Les freins, si présents, devront toujours être alimentés avec la tension V_b rapportée sur la plaque.*

(A41)

50 Hz	60 Hz			
V - 50 Hz	V - 60 Hz	P _n - 60 Hz	M _n , M _a /M _n - 60 Hz	n [min ⁻¹] - 60 Hz
230/400 Δ/Y	220 - 240 Δ 380 - 415 Y	1	0.83	1.2
400/690 Δ/Y	380 - 415 Δ			
230/400 Δ/Y	265 - 280 Δ 440 - 480 Y	1.15	1	1.2
400/690 Δ/Y	440 - 480 Δ			

Potenza nominale

Le tabelle dei dati tecnici del catalogo riportano le caratteristiche funzionali a 50 Hz in condizioni ambientali standard secondo le Norme CEI EN 60034-1 (temperatura 40 °C e altitudine <1000 m s.l.m.).
I motori possono essere impiegati a temperature comprese tra 40 °C e 60 °C applicando i declassamenti di potenza indicati nelle tabelle seguenti.

Rated power

*Catalogue rating values are calculated for 50 Hz operation and for standard ambient conditions (temperature 40 °C; elevation <1000 m a.s.l.) as per the CEI EN 60034-1 Standards.
The motors can be used within the 40 - 60 °C temperature range with rated power output adjusted by factors given in the following charts.*

Nennleistung

Die Betriebsdatentabellen des Katalogs enthalten die technischen Daten bei einer Frequenz von 50 Hz bei normalen Umgebungsbedingungen gemäß den Normen CEI EN 60034-1 (Temperatur 40°C und Höhe <1000 m ü.d.M.). Die Motoren können in größeren Temperaturen zwischen 40°C und 60°C betrieben werden, wenn man die in den Tabellen (A41) angegebenen Rückstufungen anwendet.

Puissance nominale

*Les tableaux fonctionnels du catalogue présentent les caractéristiques techniques à 50 Hz dans des conditions ambiantes standard selon les normes CEI EN 60034-1 (température 40°C et altitude <1000 m).
Les moteurs peuvent être employés à des températures comprises entre 40°C et 60°C en appliquant les déclassements de puissance indiqués dans les tableaux suivantes.*

(A42)

Temperatura ambiente / Ambient temperature / Umgebungstemperatur / Température ambiante(°C)	40°	45°	50°	55°	60°
Potenza ammissibile in % della potenza nominale / Permitted power as a % of rated power Zulässige Leistung in % der Nennleistung / Puissance admissible en % de la puissance nominale	100%	95%	90%	85%	80%

Quando è richiesto un declassamento del motore superiore al 15%, contattare il ns. Servizio Tecnico.

Should a derating factor higher than 15% apply please consult factory.

Wenn eine Motordeklassierung höher als 15% gefragt ist, wir bitten um Rückfrage.

Si un déclassement du moteur supérieur à 15% est requis, on devra contacter notre Service Technique.

Classe d'isolamento

Insulation class

Isolationsklasse

Classes d'isolation

CL F

I motori di produzione Bonfiglioli impiegano, di serie, materiali isolanti (filo smaltato, isolanti, resine d'impregnazione) in classe F.

Bonfiglioli motors use class F insulating materials (enamelled wire, insulators, impregnation resins) as compare to the standard motor.

Die Motoren von Bonfiglioli sind serienmäßig mit Isolierstoffen (Emaildraht, Isolierstoffen, Imprägnierharzen) der Klasse F ausgestattet.

De série, les moteurs fabriqués par Bonfiglioli utilisent des matériaux isolants (fil émaillé, isolants, résines d'impregnation) en classe F.

CL H

Su richiesta può venire specificata la classe di isolamento H.
In genere, per i motori in esecuzione standard la sovratemperatura dell'avvolgimento statore è contenuta entro il limite di 80 K, corrispondente alla sovratemperatura di classe B.

*Motors manufactured in insulation class H are available at request.
In standard motors, stator windings over temperature normally stays below the 80 K limit corresponding to class B over temperature.*

Auf Anfrage können sie auch in der Klasse H geliefert werden.
Allgemein hält sich die Übertemperatur der Motoren in der Standardausführung innerhalb des Grenzwerts von 80 K, der einer Übertemperatur der Klasse B entspricht.

*Sur demande, la classe d'isolation H peut être spécifiée.
En général, pour les moteurs en exécution standard, l'échauffement de l'enroulement du stator se situe dans la limite de 80 K, correspondant à un échauffement de classe B.*

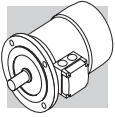

L'accurata scelta dei componenti del sistema isolante consente l'impiego dei motori anche in climi tropicali ed in presenza di vibrazioni normali.

Per applicazioni in presenza di sostanze chimiche aggressive, o di elevata umidità, è consigliabile contattare il Servizio Tecnico Bonfiglioli per la selezione del prodotto più idoneo.

A careful selection of insulating components makes the motors compatible with tropical climates and normal vibration.

For applications involving the presence of aggressive chemicals or high humidity, contact Bonfiglioli Engineering for assistance with product selection.

Die sorgfältig Wahl der Komponenten des Isoliersystem gestatten den Einsatz dieser Motoren auch unter tropischen Klimabedingungen und bei Vorliegen normaler Schwingungen.

Für den Einsatz in in der Nähe aggressiv wirkenden chemischen Substanzen oder bei hoher Luftfeuchtigkeit, wird empfohlen sich zur Wahl eines passenden Produktes mit unserem Technischen Kundendienst in Verbindung zu setzen.

Le choix soigné des composants du système d'isolation permet d'utiliser également les moteurs dans des climats tropicaux et en présence de vibrations normales.

Pour des applications en présence de substances chimiques agressives, ou d'humidité élevée, il est conseillé de contacter le Service Technique Bonfiglioli pour sélectionner le produit le plus adapté.

(A43)

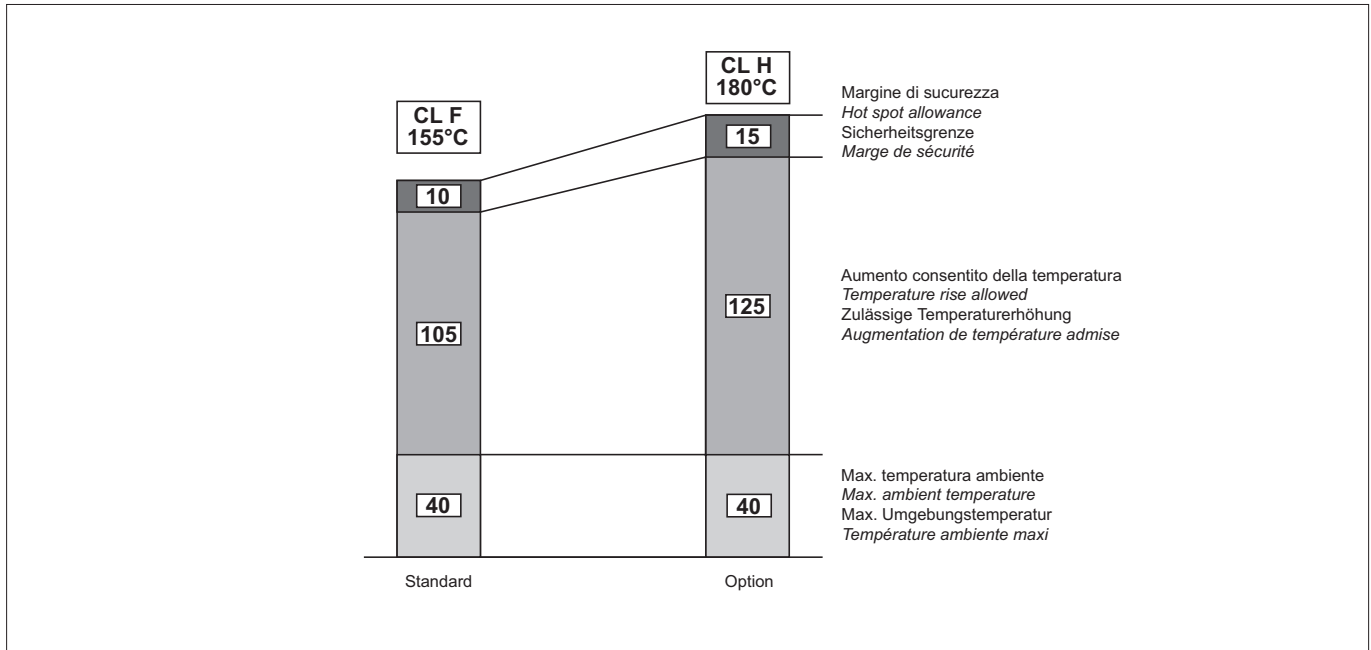

Tipo di servizio

Se non indicato diversamente la potenza dei motori riportata a catalogo si riferisce al servizio continuo S1.

Per i motori utilizzati in condizioni diverse da S1 sarà necessario identificare il tipo di servizio previsto con riferimento alle Norme CEI EN 60034-1.

In particolare, per i servizi S2 ed S3, è possibile ottenere una maggiorazione della potenza termica rispetto a quella prevista per il servizio continuo secondo quanto indicato nella tabella (A44) valida per motori ad una velocità. Per motori a doppia polarità interpellare il nostro Servizio Tecnico.

Type of duty

Unless otherwise indicated, the power of motors specified in the catalogue refers to continuous duty S1.

For motors used under conditions other than S1, the type of duty required must be adjusted with reference to CEI EN 60034-1 Standards.

In particular, for duties S2 and S3, power can be adjusted with respect to continuous duty according to data in table (A44) applicable to single speed motors. For double speed motors, contact our Technical Service.

Betriebsart

Sofern nicht anders angegeben, bezieht sich die im Katalog angegebene Motorleistung auf den Dauerbetrieb S1.

Bei den Motoren, die für eine andere Betriebsart als S1 vorgesehen sind, muß man die Betriebsart unter Bezugnahme auf die Normen CEI EN 60034-1 identifizieren.

Insbesondere kann man für die Betriebsarten S2 und S3 nach der für Motoren mit einer Drehzahl. Gültigen Tabelle (A44) eine Überdimensionierung der Leistung für den Dauerbetrieb im Vergleich zur vorgesehenen Betriebsart erreichen. Für polumschaltbaren Motoren, bitte Rückfrage.

Type de service

sauf indication contraire, la puissance des moteurs reportée dans le catalogue se réfère au service continu S1.

Pour les moteurs utilisés dans des conditions différentes de S1, il sera nécessaire d'identifier le type de service prévu en se référant aux normes CEI EN 60034-1.

En particulier, pour les services S2 et S3, il est possible d'obtenir une majoration de la puissance par rapport à celle prévue pour le service continu selon ce qui est indiqué dans le tableau (A44) valable pour les moteurs à une vitesse. Pour les moteurs à double polarité, contacter notre Service Technique.

(A44)

	Servizio / Duty / Betriebsart / Service						
	S2			S3 *			S4 - S9
	Durata del ciclo (min) / Cycle duration (min) Zyklusdauer (min) / Durée du cycle (min)			Rapporto di intermittenza (I) / Cyclic duration factor (I) Relative Einschaltdauer (I) / Rapport d'intermittence (I)			Interpellarci Consult factory Rückfrage Nous contacter
	10	30	60	25%	40%	60%	
f _m	1.35	1.15	1.05	1.25	1.15	1.1	

* La durata del ciclo dovrà comunque essere uguale o inferiore a 10 minuti; se superiore interpellare il nostro Servizio Tecnico.

** Cycle duration must, in any event, be equal to or less than 10 minutes; if this time is exceeded, please contact our Technical Service.*

* Die Zyklusdauer muß in jedem Fall kleiner oder gleich 10 Minuten sein. Wenn sie darüber liegt, unseren Technischen Kundendienst zu Rate ziehen.

** La durée du cycle devra être inférieure ou égale à 10 minutes. Si supérieure, contacter notre Service Technique.*

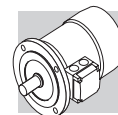

Rapporto di intermittenza:

Cyclic duration factor:

Relative Einschaltdauer:

Rapport d'intermittence:

$$I = \frac{t_f}{t_f + t_r} \cdot 100 \quad (23)$$

t_f = tempo di funzionamento a carico costante
 t_r = tempo di riposo

t_f = work time under constant load
 t_r = rest time

t_f = Betriebszeit mit konstanter Last
 t_r = Aussetzzeit

t_f = temps de fonctionnement à charge constante
 t_r = temps de repos

Servizio di durata limitata S2

Limited duration duty S2

Kurzzeitbetrieb S2

Service de durée limitée S2

Caratterizzato da un funzionamento a carico costante per un periodo di tempo limitato, inferiore a quello richiesto per raggiungere l'equilibrio termico, seguito da un periodo di riposo di durata sufficiente a ristabilire, nel motore, la temperatura ambiente.

This type of duty is characterized by operation at constant load for a limited time, which is shorter than the time required to reach thermal equilibrium, followed by a rest period of sufficient duration to restore ambient temperature in the motor.

Betrieb mit konstanter Last für eine begrenzte Zeit, die unter der Zeit liegt, die zum Erreichen des thermischen Gleichgewichts benötigt wird, gefolgt von einer Aussetzzeit, die so lang ist, daß der Motor wieder auf die Umgebungstemperatur abkühlen kann.

Caractérisé par un fonctionnement à charge constante pour une période de temps limitée, inférieure à celle nécessaire pour atteindre l'équilibre thermique, suivie par une période de repos de durée suffisante pour rétablir, dans le moteur, la température ambiante.

Servizio intermittente periodico S3:

Periodical intermittent duty S3:

Periodische Einschaltsdauer S3:

Service intermittent périodique S3

Caratterizzato da una sequenza di cicli di funzionamento identici, ciascuno comprendente un periodo di funzionamento a carico costante ed un periodo di riposo. In questo servizio, la corrente di avviamento non influenza la sovratemperatura in modo significativo.

This type of duty is characterized by a sequence of identical operation cycles, each including a constant load operation period and a rest period. For this type of duty, the starting current does not significantly influence overtemperature.

Betrieb mit aufeinanderfolgenden identischen Betriebszyklen, die alle einen kurzzeitigen Betrieb mit konstanter Belastung und eine Aussetzzeit einschließen. Bei dieser Betriebsart beeinflusst der Anlaufstrom die Übertemperatur nicht in signifikanter Weise.

Caractérisé par une séquence de cycles de fonctionnement identiques, comprenant chacun une période de fonctionnement à charge constante et une période de repos. Dans ce service, le courant de démarrage n'influence pas l'excès de température de façon significative.

Funzionamento con alimentazione da inverter

Inverter-controlled motors

Betrieb mit Versorgung über Inverter

Fonctionnement avec alimentation par variateur de vitesse

I motori elettrici della serie BN ed M possono essere utilizzati con alimentazione da inverter PWM, e tensione nominale all'ingresso del convertitore fino a 500 V.

The electric motors of series BN and M may be used in combination with PWM inverters with rated voltage at transformer input up to 500 V. Standard motors use a phase insulating system with separators, class 2 enamelled wire and class H impregnation resins (1600V peak-to-peak voltage pulse capacity and rise edge $t_s > 0.1\mu s$ at motor terminals). Table (A54) shows the typical torque/speed curves referred to S1 duty for motors with base frequency $f_b = 50$ Hz.

Die Elektromotoren der Serie BN und M können über einen Inverter PWM und mit einer Nennspannung am Wandlereingang bis zu 500 V versorgt werden. Das an den Serienmotoren angewendete System sieht eine Phasenisolierung mittels Trennvorrichtungen vor, ebenso wie einen Emailldraht mit Grad 2 und Imprägnierharze in der Klasse H vor (Abdichtungsgrenze bei Spannungsimpuls 1600V Spitze-Spitze und Anstiegsfront $t_s > 0.1\mu s$ an den Motorklemmen). Die typischen Merkmale von Drehmoment/Geschwindigkeit im Betrieb S1 für Motoren mit einer Grundfrequenz $f_b = 50$ Hz werden in der Tab. (A54) angegeben. Bei Betriebsfrequenzen unter ungefähr 30 Hz müssen die selbstlüftenden Standardmotoren (IC411) aufgrund der in diesem Fall abnehmenden Belüftung entsprechend paarweise deklassiert, oder in Alternative, mit unabhängigen Servoventilatoren ausgestattet werden. Bei über der Grundfrequenz liegenden Frequenzen arbeitet der Motor,

Les moteurs électriques de la série BN et M peuvent être utilisés avec alimentation par variateur PWM, et tension nominale en entrée du convertisseur jusqu'à 500V. Le système adopté sur les moteurs de série prévoit l'isolation de phase avec des séparateurs, l'utilisation de fil émaillé niveau 2 et résines d'imprégnation de classe H (limite de maintien à l'impulsion de tension 1600V pic-pic et front de montée $t_s > 0.1\mu s$ aux bornes moteur). Les caractéristiques typiques couple/vitesse en service S1 pour moteur avec fréquence de base $f_b = 50$ Hz sont indiquées dans le tab. (A54).

Il sistema isolante sui motori di serie prevede l'isolamento di fase con separatori, l'utilizzo di filo smaltato in grado 2 e resine d'imprégnazione in classe H (limite di tenuta all'impulso di tensione 1600V picco-picco e fronte di salita $t_s > 0.1\mu s$ ai morsetti motore).

Because ventilation is somewhat impaired in operation at lower frequencies (about 30 Hz), standard motors with incorporated fan (IC411) require adequate torque derating or - alternately - the addition of a separate supply fan cooling. Above base frequency, upon reaching the maximum output voltage of the inverter, the motor enters a steady-power field of operation, and shaft torque drops with ratio (f/f_b) .

Pour des fréquences de fonctionnement inférieures à environ 30 Hz, à cause de la diminution de la ventilation, les moteurs standards autoventilés (IC411) doivent être opportunément déclassés au niveau du couple ou, en alternative, doivent être équipés de servoventilateur indépendant. Pour des fréquences supérieures à la fréquence de base, une fois

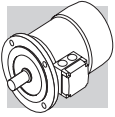

campo di funzionamento a potenza costante, con coppia all'albero che si riduce ca. con il rapporto (f/f_b) . Poiché la coppia massima del motore decresce ca. con $(f/f_b)^2$, il margine di sovraccarico ammesso dovrà essere progressivamente ridotto.

As motor maximum torque decreases with $(f/f_b)^2$, the allowed overloading must be reduced progressively.

nach Erreichen des max. Spannungswerts am Inverterausgang in einem Betriebsbereich unter konstanter Leistung mit einem Drehmoment an der Welle, der sich ungefähr im Verhältnis (f/f_b) reduziert. Da das max. Drehmoment des Motors mit ungefähr $(f/f_b)^2$ abnimmt, muss auch der zulässige Überbelastungsgrenzwert progressiv reduziert werden.

la valeur maximale de tension de sortie du variateur atteinte, le moteur fonctionne dans une plage de fonctionnement à puissance constante, avec couple à l'arbre qui se réduit avec le rapport (f/f_b) . Dans la mesure où le couple maximal du moteur diminue avec $(f/f_b)^2$, la marge de surcharge admise doit être progressivement réduite.

(A45)

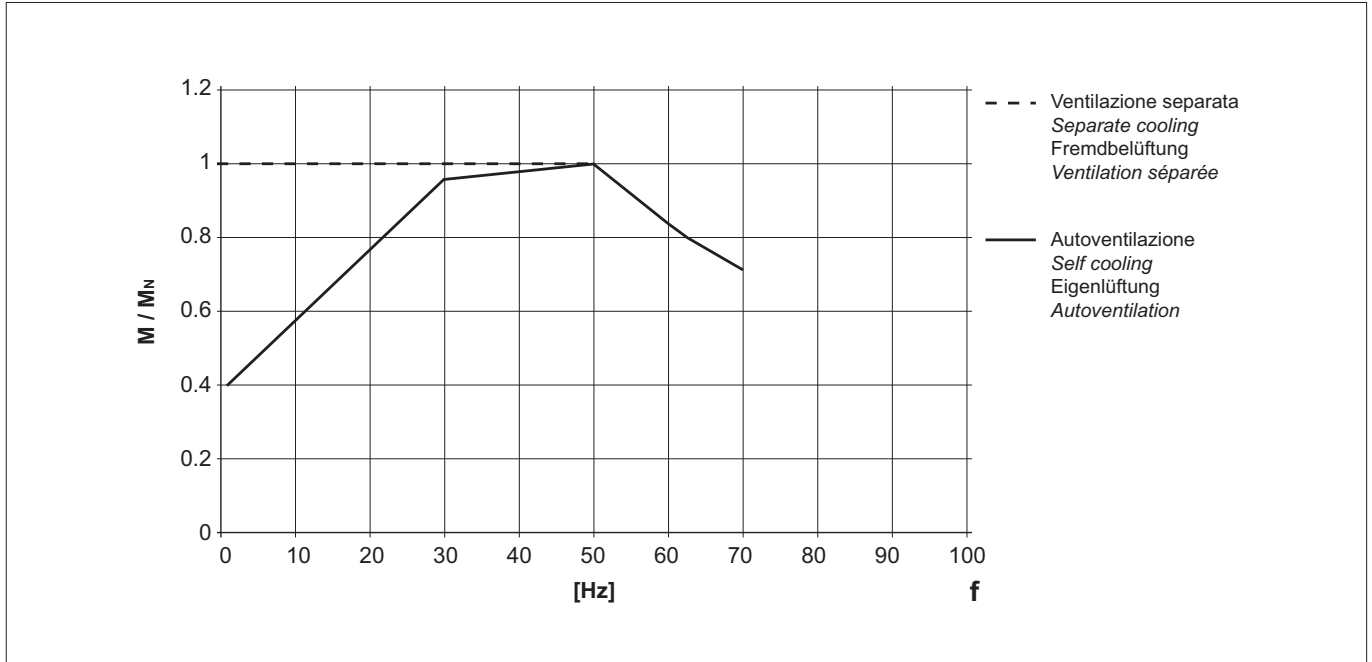



Per funzionamento oltre la frequenza nominale, la velocità limite meccanica dei motori è riportata in tabella (A45):

Table (A45) reports the mechanical limit speed for motor operation above rated frequency:

Für einen Betrieb, der über die Nennfrequenz hinausgeht, wird die Geschwindigkeitsbegrenzung der Motoren in der Tabelle (A45) angegeben:

En cas de fonctionnement au-delà de la fréquence nominale, la vitesse limite mécanique des moteurs est indiquée dans le tableau (A45):

(A46)

		n [min ⁻¹]		
		2p	4p	6p
≤ BN 112	M05...M3	5200	4000	3000
BN 132...BN 200L	M4, M5	4500	4000	3000

A velocità superiori alla nominale i motori presentano maggiori vibrazioni meccaniche e rumorosità di ventilazione; è consigliabile, per queste applicazioni, un bilanciamento del rotore in grado R e l'eventuale montaggio del servoventilatore indipendente.

Above rated speed, motors generate increased mechanical vibration and fan noise. Class R rotor balancing is highly recommended in these applications. Installing a separate supply fan cooling may also be advisable.

Bei Geschwindigkeiten über die Nennwerte hinaus, weisen die Motoren höhere mechanische Schwingungen und mehr Funktionsgeräusche bei der Belüftung auf. Bei diesen Applikationen wird ein Auswuchten des Rotors im Grad R und eine eventuelle Montage des unabhängigen funktionierenden Servoventilators empfohlen.

A des vitesses supérieures à la vitesse nominale, les moteurs présentent plus de vibrations mécaniques et de bruit de ventilation ; pour ces applications, il est conseillé d'effectuer un équilibrage du rotor en niveau R et de monter éventuellement un servoventilateur indépendant.

Il servoventilatore e, se presente, il freno elettromagnetico devono sempre essere alimentati direttamente da rete.

Remote-controlled fan and brake (if fitted) must always be connected direct to mains power supply.

Der Servoventilator und, falls vorhanden, die elektromagnetische Bremse müssen immer direkt über das Netz gespeist werden.

Le servoventilateur et, si présent, le frein électromagnétique doivent toujours être alimentés directement par le réseau.

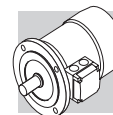

Frequenza massima di avviamento Z

Nelle tabelle dei dati tecnici motori è indicata la max frequenza di inserzione a vuoto Z_0 con $I = 50\%$ riferita alla versione autofrenante. Questo valore definisce il numero max di avviamenti orari a vuoto che il motore può sopportare senza superare la max temperatura ammessa dalla classe di isolamento F.

Nel caso pratico di motore accoppiato ad un carico esterno con potenza assorbita P_r , massa inerziale J_c e coppia resistente media durante l'avviamento M_L , il numero di avviamenti ammissibile si può calcolare in modo approssimato con la seguente formula:

Permissible starts per hour, Z

The rating charts of brakemotors lend the permitted number of starts Z_0 , based on 50% intermittence and for unloaded operation.

The catalogue value represents the maximum number of starts per hour for the motor without exceeding the rated temperature for the insulation class F.

To give a practical example for an application characterized by inertia J_c , drawing power P_r and requiring mean torque at start-up M_L the actual number of starts per hour for the motor can be calculated approximately through the following equation:

Maximale Schaltungshäufigkeit Z

In den Tabellen mit den Technischen Daten der Motoren ist die maximale Schaltungshäufigkeit im Leerlauf Z_0 bei relativer Einschaltdauer $I = 50\%$ bezüglich auf die Bremsausführung. Dieser Wert definiert die maximale Anzahl von Anfahrten im Leerlauf pro Stunde, die der Motor ertragen kann, ohne die durch die Isolierstoffklasse F festgelegte maximal zulässige Temperatur zu überschreiten.

Im praktischen Fall eines mit einer externen Last verbundenen Motors mit einer Leistungsaufnahme von P_r , Trägheitsmasse J_c und mittlerem Gegenmoment während des Anfahrens von M_L kann die zulässige Anzahl Anfahrten mit folgender Formel approximativ berechnet werden:

Fréquence maximum de démarrage Z

Dans les tableaux des caractéristiques techniques des moteurs se trouve la fréquence maximum d'insertion à vide Z_0 avec intermittence $I = 50\%$ référée à la version frein. Cette valeur définit un nombre maximum de démarrages horaires à vide que le moteur peut supporter sans dépasser la température maximum admise par la classe d'isolation F.

Dans le cas pratique de moteur accouplé à une charge extérieure avec puissance absorbée P_r , masse inertielle J_c et couple résistant moyen pendant le démarrage M_L , le nombre de démarrages admissible peut se calculer de façon approximative avec la formule suivante:

$$Z = \frac{Z_0 \cdot K_c \cdot K_d}{K_J}$$

dove:

$$K_J = \frac{J_m + J_c}{J_m} = \text{fattore di inerzia}$$

$$K_c = \frac{M_a - M_L}{M_a} = \text{fattore di coppia}$$

K_d = fattore di carico
vedi tabella (A46)

where:

$$K_J = \frac{J_m + J_c}{J_m} = \text{inertia factor}$$

$$K_c = \frac{M_a - M_L}{M_a} = \text{torque factor}$$

K_d = load factor
see table (A46)

wobei gilt:

$$K_J = \frac{J_m + J_c}{J_m} = \text{Trägheitsfaktor}$$

$$K_c = \frac{M_a - M_L}{M_a} = \text{Drehmomentsfaktor}$$

K_d = Lastfaktor
siehe Tabelle (A46)

où:

$$K_J = \frac{J_m + J_c}{J_m} = \text{facteur d'inertie}$$

$$K_c = \frac{M_a - M_L}{M_a} = \text{facteur de couple}$$

K_d = facteur de charge
voir tableau (A46)

(A47)

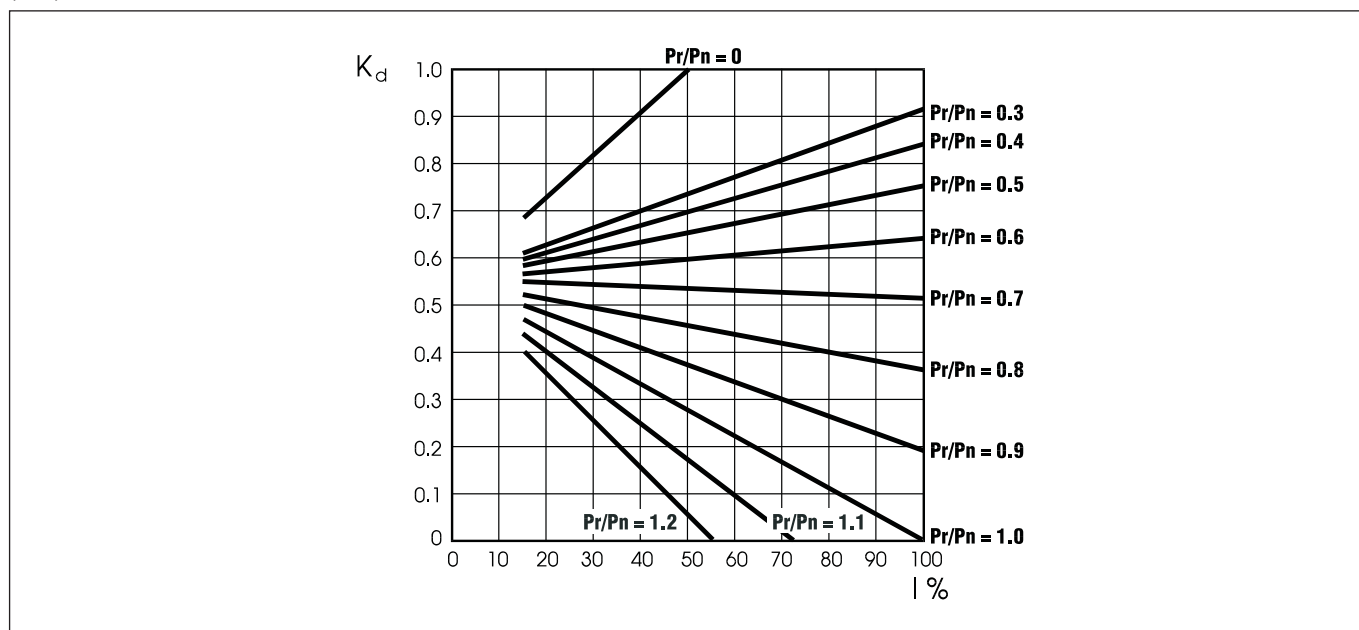

Con il numero di avviamenti così ottenuto si dovrà in seguito verificare che il massimo lavoro di frenatura sia compatibile con la capacità termica del freno W_{max} indicata nella tabella (A54).

If actual starts per hour is within permitted value (Z) it may be worth checking that braking work is compatible with brake (thermal) capacity W_{max} also given in table (A54) and dependent on the number of switches (c/h).

Auf Grundlage der so berechneten Anzahl Schaltungen muß man dann prüfen, ob die maximale Bremsarbeit mit der Wärmegrenzleistung der Bremse W_{max} kompatibel ist, die in die Tabelle (A54) angegeben ist.

Avec le nombre de démarrages ainsi obtenu, il faudra ensuite vérifier que le travail maximum de freinage soit compatible avec la capacité thermique du frein W_{max} indiquée dans le table (A54).

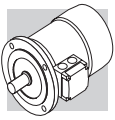

M5 - MOTORI ASINCRONI AUTOFRENANTI

M5 - ASYNCHRONOUS BRAKE MOTORS

M5 - DREHSTROMBREMS- M5 - MOTEURS FREIN ASYN- MOTOREN CHRONES

Funzionamento

L'esecuzione autofrenante prevede l'impiego di freni a pressione di molle alimentati in c.c. (tipo FD) o in c.a. (tipo FA, BA). Tutti i freni funzionano secondo il principio di sicurezza, ossia intervengono in seguito alla pressione esercitata dalle molle, in mancanza di alimentazione.

Operation

Versions with incorporated brake use spring-applied DC (FD option) or AC (FA, BA options) brakes. All brakes are designed to provide fail-safe operation, meaning that they are applied by spring-action in the event of power failure.

Betriebsweise

Die selbstbremsende Ausführung der Motoren sieht den Einsatz von Federdruckbremsen vor, die mit Gleichstrom (Typ FD) oder mit Wechselstrom (Typ FA, BA) gespeist werden. Alle Bremsen arbeiten gemäß dem Sicherheitsprinzip, d.h. sie greifen, im Fall eines Stromausfalls in Folge eines auf die Feder ausgeübten Drucks ein.

Fonctionnement

L'exécution avec frein prévoit l'utilisation de freins à pression de ressorts alimentés en c.c. (type FD) ou en c.a. (type FA, BA). Tous les freins fonctionnent selon le principe de sécurité, c'est-à-dire qu'ils interviennent suite à la pression exercée par les ressorts, en cas de coupure d'alimentation.

(A48)

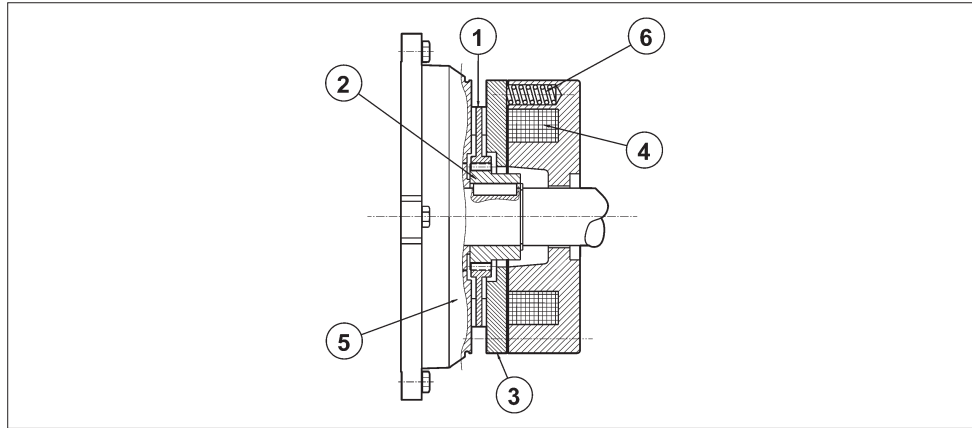

Legenda:

- ① disco
- ② mozzo
- ③ áncora mobile
- ④ bobina
- ⑤ scudo post.motore
- ⑥ molle

Key:

- ① brake disc
- ② disc carrier
- ③ pressure plate
- ④ brake coil
- ⑤ motor rear shield
- ⑥ brake springs

Zeichenerklärung:

- ① Brems scheinbe
- ② Nabe
- ③ Beweglicher Anker
- ④ Ringspule
- ⑤ Motorschild
- ⑥ Schußfedern

Légende:

- ① disque
- ② moyeu d'entraînement
- ③ disque de freinage
- ④ bobine de frein
- ⑤ flasque-frein
- ⑥ ressort de frein

In mancanza di tensione, l'ancora mobile spinta dalle molle di pressione blocca il disco freno tra la superficie dell'ancora stessa e lo scudo motore impedendo la rotazione dell'albero. Quando la bobina viene eccitata, l'attrazione magnetica esercitata sull'ancora mobile vince la reazione elastica delle molle e libera il disco freno, e conseguentemente l'albero motore con esso solidale.

When voltage is interrupted, pressure springs push the armature plate against the brake disc. The disc becomes trapped between the armature plate and motor shield and stops the shaft from rotation. When the coil is energized, a magnetic field strong enough to overcome spring action attracts the armature plate, so that the brake disc – which is integral with the motor shaft – is released.

Wenn die Spannungsversorgung abfällt, sorgt der bewegliche, von den Druckfedern geschobene Anker für die Blockierung der Bremsscheibe zwischen der Ankerfläche und dem Motorschild und blockiert damit den Rotor. Wird die Spule erregt, kommt es durch den magnetischen auf den beweglichen Anker wirkenden Anzug zur Überwindung der elastischen Federkraft und zum Lösen der Bremsscheibe, wodurch der rotor wieder freigegeben wird.

En cas de coupure de courant, l'armature mobile, poussée par les ressorts, bloque le disque de frein entre la surface de l'armature et le bouclier moteur en empêchant la rotation de l'arbre. Lorsque la bobine est excitée, l'attraction magnétique exercée sur l'armature mobile annule la réaction élastique des ressorts et libère le disque de frein, et par conséquent l'arbre moteur, qui est solidaire.

Caratteristiche generali

- Coppie frenanti elevate (generalmente $M_b \approx 2 M_n$) e regolabili.
- Disco freno con anima in acciaio a doppia guarnizione d'attrito (materiale a bassa usura, senza amianto).
- Cava esagonale sull'albero motore, lato ventola (N.D.E.), per rotazione manuale (non prevista quando sono presenti le opzioni PS, RC, TC, U1, U2, EN1, EN2, EN3).
- Sblocco meccanico manuale.
- Trattamento anticorrosivo di tutte la superfici del freno.
- Isolamento in classe F

Most significant features

- High braking torques (normally $M_b \approx 2 M_n$), braking torque adjustment.
- Steel brake disc with double friction lining (low-wear, asbestos-free lining).
- Hexagonal seat on motor shaft fan end (N.D.E.) for manual rotation (not compatible with options PS, RC, TC, U1, U2, EN1, EN2, EN3).
- Manual release lever.
- Corrosion-proof treatment on all brake surfaces.
- Insulation class F

Allgemeine Eigenschaften

- Hohe und regulierbare Bremsmomente (allgemein $M_b \approx 2 M_n$).
- Bremsscheibe mit Stahlkern und doppeltem Bremsbelag (Material mit geringem Verschleiß, asbestfrei).
- Sechskant hinten an der Motorwelle, auf Lüfterradseite (N.D.E.), für eine manuelle Drehung des Rotors mit einem Inbusschlüssel. (nicht lieferbar, wenn die Optionen PS, RC, TC, U1, U2, EN1, EN2, EN3) bestellt wurden.
- Manuell zu betätigende, mechanische Bremslüftvorrichtung.
- Korrosionsschutzbehandlung an allen Flächen der Bremse.
- Isolierung in Klasse F

Caractéristiques générales

- Couples de freinage élevés (généralement $M_b \approx 2 M_n$) et réglables.
- Disque de frein avec structure en acier à double garniture de frottement (matière à faible usure, sans amiante).
- Empreinte hexagonale sur l'arbre moteur, côté ventilateur (N.D.E.), pour la rotation manuelle (non prévue en cas de présence des options PS, RC, TC, U1, U2, EN1, EN2, EN3).
- Déblocage mécanique manuel.
- Traitement anticorrosion sur toute la surface du frein.
- Isolation en classe F

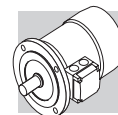

**M6 - MOTORI AUTOFRENANTI
IN C.C., TIPO BN_FD**

**M6 - DC BRAKE MOTORS
TYPE BN_FD**

**M6 - DREHSTROMBREMSMO-
TOREN MIT GLEICH-
STROMBREMSE: TYP
BN_FD**

**M6 - MOTEURS FREIN EN C.C.,
TYPE BN_FD**

Grandezze: BN 63 ... BN 200L

Frame sizes: BN 63 ... BN 200L

Baugrößen: BN 63 ... BN 200L

Tailles : BN 63 ... BN 200L

(A49)

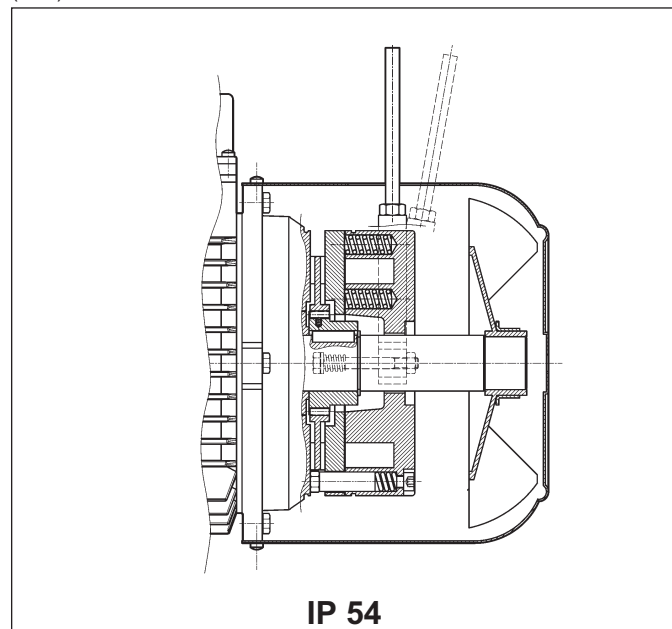

IP 54

(A50)

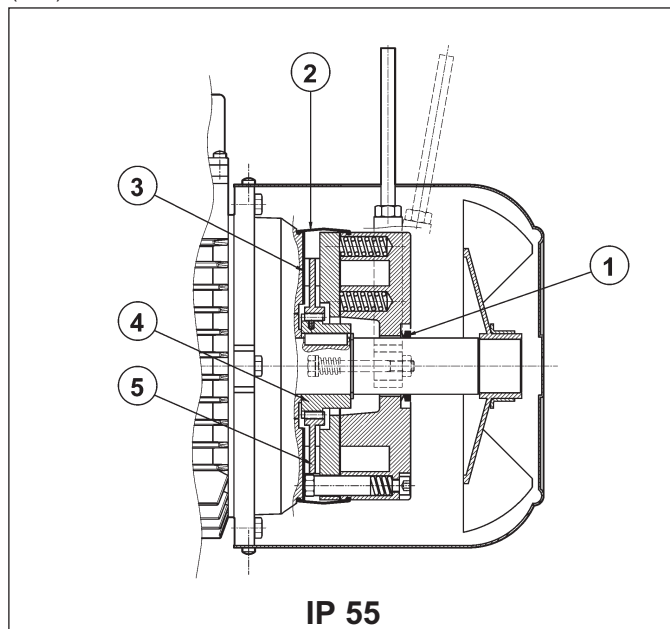

IP 55

Freno elettromagnetico con bobina toroidale in **corrente continua** fissato con viti allo scudo motore; le molle di precarico realizzano il posizionamento assiale del corpo magnete.

Il disco freno è scorrevole sul mozzo trascinatore in acciaio calettato sull'albero e previsto di molla antivibrazione.

I motori sono forniti con freno tarato in fabbrica al valore di coppia riportato nelle tabelle dati tecnici; la coppia frenante può essere regolata modificando il tipo e/o il numero delle molle.

A richiesta, i motori possono essere previsti di leva per lo sblocco manuale con ritorno automatico (R) o con mantenimento della posizione di rilascio freno (RM); per la posizione angolare della leva di sblocco vedi descrizione della relativa variante alla pag. 366.

Il freno FD garantisce elevate prestazioni dinamiche e bassa rumorosità; le caratteristiche d'intervento del freno in corrente continua possono essere ottimizzate in funzione dell'applicazione, utilizzando i vari tipi di alimentatore disponibili e/o realizzando l'opportuno cablaggio.

Direct current toroidal-coil electromagnetic brake bolted onto motor shield. Preloading springs provide axial positioning of magnet body.

Brake disc slides axially on steel hub shrunk onto motor shaft with anti-vibration spring.

Brake torque factory setting is indicated in the corresponding motor rating charts. Braking torque may be modified by changing the type and/or number of springs.

At request, motors may be equipped with manual release lever with automatic return (R) or system for holding brake in the released position (RM).

See variant at page 366 for available release lever locations.

FD brakes ensure excellent dynamic performance with low noise. DC brake operating characteristics may be optimized to meet application requirements by choosing from the various rectifier/power supply and wiring connection options available.

Elektromagnetische Bremse mit Ringwicklungsspule für **Gleichstromspannung**, die mittels Schrauben am hinteren Motorschild befestigt ist. Die Federn sorgen für die axiale Ausrichtung des Magnetkörpers.

Die Bremsscheibe gleitet axial auf der Mitnehmernabe aus Stahl, die über eine Paßfeder mit der Motorwelle verbunden und mit einer Schwingungsdämpfung ausgestattet ist.

Die Motoren werden vom Hersteller auf den in der Tabelle der technischen Daten angegebenen Bremsmoment eingestellt; das Bremsmoment kann durch das Ändern des Typs und/oder der Anzahl der Federn reguliert werden.

Auf Anfrage können die Motoren mit einem Bremslüfthebel für die manuelle Lüftung der Bremse mit selbstständiger Rückstellung (R) ohne Arretierung oder mit arretierbarem Lüfthebel (RM) geliefert werden. Die Festlegung der Position des Bremslüfthebel in Abhängigkeit von der Klemmkastenlage erfolgt durch die Option auf Seite 366.

Die Bremse vom Typ FD garantiert hohe dynamische Leistungen und niedrige Laufgeräusche. Die Ansprechigenschaften der Bremse unter Gleichstrom können in Abhängigkeit zur jeweiligen Anwendung durch den Einsatz der verschiedenen verfügbaren Gleichrichter oder durch eine entsprechenden Anschluß der Bremse optimiert werden.

Frein électromagnétique avec bobine toroïdale en **courant continu**, fixé avec des vis au bouclier moteur; les ressorts de précharge réalisent le positionnement axial de la bobine.

Le disque frein coulisse de façon axiale sur le moyeu d'entraînement en acier calé sur l'arbre et doté de ressort antivibration.

Les moteurs sont fournis avec frein pré réglé en usine à la valeur de couple indiquée dans les tableaux des caractéristiques techniques; le couple de freinage peut être réglé en modifiant le type et/ou le nombre de ressorts.

Sur demande, les moteurs peuvent être équipés de levier pour le déblocage manuel avec retour automatique (R) ou avec maintien de la position de déblocage frein (RM); pour la position angulaire du levier de déblocage, voir description de la variante correspondante à la page 366.

Le frein FD garantit des performances dynamiques élevées et un faible niveau de bruit; les caractéristiques d'intervention du frein en courant continu peuvent être optimisées en fonction de l'application en utilisant les différents types de dispositifs d'alimentation disponibles et/ou en réalisant un câblage approprié.

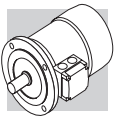

Grado di protezione

L'esecuzione standard prevede il grado di protezione IP54. In opzione il motore autofrenante tipo FD viene fornito con grado di protezione **IP 55**, prevedendo le seguenti varianti costruttive:

- ① anello V-ring posizionato sull'albero motore N.D.E.
- ② fascia di protezione in gomma
- ③ anello in acciaio inox interposto tra scudo motore e disco freno
- ④ mozzo trascinatore in acciaio inox
- ⑤ disco freno in acciaio inox

Degree of protection

Standard protection class is IP54.

Brake motor FD is also available in protection class **IP 55**, which mandates the following variants:

- ① V-ring at N.D.E. of motor shaft
- ② dust and water-proof rubber boot
- ③ stainless steel ring placed between motor shield and brake disc
- ④ stainless steel hub
- ⑤ stainless steel brake disc

Schutzart

Die Standardausführung ist Schutzart IP54 vor. Optional kann der Bremsmotor vom Typ FD in der Schutzart **IP 55** geliefert werden, wobei sind folgende Komponenten eingesetzt werden:

- ① V-Ring an der Motorwelle N.D.E.
- ② Schutzring aus Gummi
- ③ Ring aus rostfreiem Stahl zwischen Motorschild und
- ④ Bremsscheibe Mitnehmer-nabe aus rostfreiem Stahl
- ⑤ Bremsscheibe aus rostfreiem Stahl

Degré de protection

L'exécution standard prévoit le degré de protection IP54.

En option, le moteur frein type FD est fourni avec degré de protection **IP 55**, en prévoyant les variantes de construction suivantes :

- ① bague V-ring positionnées sur l'arbre moteur N.D.E.
- ② bande de protection en caoutchouc
- ③ bague en acier inox interposée entre le bouclier moteur et le disque de frein
- ④ moyeu d'entraînement en acier inox
- ⑤ disque frein en acier inox

Alimentazione freno FD

L'alimentazione della bobina freno in c.c. è prevista per mezzo di opportuno raddrizzatore montato all'interno della scatola coprimorsetti e già cablato alla bobina del freno.

Per motori a singola polarità è inoltre previsto di serie il collegamento del raddrizzatore alla morsettiera motore.

Indipendentemente dalla frequenza di rete, la tensione standard di alimentazione del raddrizzatore V_B ha il valore indicato nella tabella (A51) qui di seguito:

FD brake power supply

A rectifier accommodated inside the terminal box feeds the DC brake coil. Wiring connection across rectifier and brake coil is performed at the factory.

On all single-pole motors, rectifier is connected to the motor terminal board.

Rectifier standard power supply voltage V_B is as indicated in the following table (A51), regardless of mains frequency:

Spannungsversorgung der Bremse FD

Die Versorgung der Gleichstrombremsspule erfolgt über einen Gleichrichter im Klemmenkasten der bei Lieferung, wenn nicht anders bestellt, bereits mit der Bremsspule verkabelt ist.

Bei den einpoligen Motoren ist serienmäßig der Anschluss des Gleichrichters an die Motorspannung vorgesehen. Unabhängig von der Netzfrequenz erfolgt die Versorgung des Gleichrichters V_B über die in der nachstehenden Tabelle (A51) angegebenen Standardspannung:



Alimentation frein FD

L'alimentation de la bobine de frein en c.c. est prévue au moyen d'un redresseur approprié monté à l'intérieur de la boîte à bornes et déjà câblé à la bobine de frein.

De plus, pour les moteurs à simple polarité, le raccordement du redresseur au bornier moteur est prévu de série.

Indépendamment de la fréquence du réseau, la tension standard d'alimentation du redresseur V_B correspond à la valeur indiquée dans le tableau (A51) ci-dessous :

(A51)

2, 4, 6 P				1 speed	
		BN_FD / M_FD		alimentazione freno da morsettiera brake connected to terminal board power supply Bremsversorgung über die Motorspannung Alimentation frein depuis boîte à bornes	alimentazione separata separate power supply Separate Versorgung Alimentation séparée
		$V_{mot} \pm 10\%$ 3 ~	$V_B \pm 10\%$ 1 ~		
BN 63...BN 132	M05...M4LB	230/400 V – 50 Hz	230 V	standard	specificare $V_B SA$ o $V_B SD$ specify $V_B SA$ or $V_B SD$ $V_B SA$ oder $V_B SD$ angeben spécifier $V_B SA$ ou $V_B SD$
BN 160...BN 200	M4LC...M5	400/690 V – 50 Hz	400 V	standard	specificare $V_B SA$ o $V_B SD$ specify $V_B SA$ or $V_B SD$ $V_B SA$ oder $V_B SD$ angeben spécifier $V_B SA$ ou $V_B SD$



Per i motori a doppia polarità l'alimentazione standard del freno è da linea separata con tensione d'ingresso al raddrizzatore V_B come indicato in tabella (A52):

Switch-pole motors feature a separate power supply line for the brake with rectifier input voltage V_B as indicated in the table (A52):

Die polumschaltbaren Motoren müssen immer mit separater Bremsversorgungsspannung betrieben werden, deshalb erfolgt die Lieferung standardmäßig ohne Anschluß der Bremse an die Motorspannung, da diese mit einer am Eingang des Gleichrichters V_B anliegenden Spannung versorgt werden muß, entsprechend Werte in der nachstehenden Tabelle (A52):

Pour les moteurs à double polarité, l'alimentation standard du frein dérive d'une ligne séparée avec tension d'entrée au redresseur V_B comme indiqué dans le tableau (A52):

(A52)

2/4, 2/6, 2/8, 2/12, 4/6, 4/8 P				2 speed	
		BN_FD / M_FD		alimentazione freno da morsettiera brake powered via terminal board Bremsversorgung über die Motorspannung Alimentation frein depuis boîte à bornes	alimentazione separata separate power supply Separate Versorgung Alimentation séparée
		$V_{mot} \pm 10\%$ 3 ~	$V_B \pm 10\%$ 1 ~		
BN 63...BN 132	M05...M4LB	400 V – 50 Hz	230 V		specificare $V_B SA$ o $V_B SD$ specify $V_B SA$ or $V_B SD$ $V_B SA$ oder $V_B SD$ angeben spécifier $V_B SA$ ou $V_B SD$

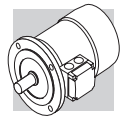



Il raddrizzatore è del tipo a diodi a semionda ($V_{c.c} \approx 0,45 \times V_{c.a.}$) ed è disponibile nelle versioni **NB**, **SB**, **NBR** e **SBR**, come dettagliato nella tabella (A53) seguente:

The diode half-wave rectifier ($V_{DC} \approx 0,45 \times V_{AC}$) is available in versions **NB**, **SB**, **NBR** e **SBR**, as detailed in the table (A53) below:

Bei dem Gleichrichter handelt es sich um einen Typ mit Halbwellendioden ($V_{c.c} \approx 0,45 V_{c.a.}$). Er ist in den Versionen **NB**, **SB**, **NBR** und **SBR**, gemäß den Details in der nachstehenden Tabelle (A53), verfügbar:

Le redresseur est du type à diodes à demi-onde ($V_{c.c} \approx 0,45 \times V_{c.a.}$) et il est disponible dans les versions **NB**, **SB**, **NBR** et **SBR**, comme indiqué de façon détaillée dans le tableau (A53) suivant :

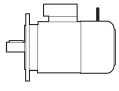
(A53)

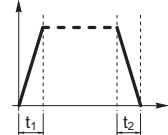
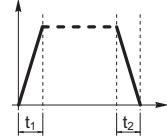
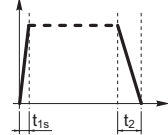
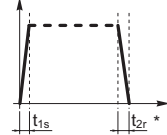
			freno brake Bremsse frein				
				standard	a richiesta at request auf Anfrage Sur demande		
BN 63		M05	FD 02				
BN 71		M1	FD 03				
			FD 53				
BN 80		M2	FD 04				
BN 90S		—	FD 14				
BN 90L		—	FD 05				
BN 100		M3	FD 15				
—			FD 55				
BN 112		—	FD 06S				
BN 132...160MR		M4	FD 56				
BN 160L - BN 180M		M5	FD 06				
BN 180L - NM 200L		—	FD 07				

(*) $t_{2c} < t_{2r} < t_2$

Il raddrizzatore **SB** a controllo elettronico dell'eccitazione, riduce i tempi di sblocco del freno sovraccitando l'elettromagnete nei primi istanti d'inserzione, per passare poi al normale funzionamento a semionda a distacco del freno avvenuto.

Rectifier **SB** with electronic energizing control over-energizes the electromagnet upon power-up to cut brake release response time and then switches to normal half-wave operation once the brake has been released.

Der Gleichrichter **SB** mit elektronischer Kontrolle der Erregung reduziert die Bremslösezeiten, indem er die Bremsspule in den ersten Momenten der Einschaltung übermäßig erregt, um dann, nach erfolgter Bremslösung, in die normale Halbwellenfunktion umzuschalten.

Le redresseur **SB** à contrôle électronique de l'excitation réduit les temps de déblocage du frein en surexcitant l'électro-aimant durant les premiers instants d'enclenchement pour passer ensuite au fonctionnement normal à demi-onde une fois le frein désactivé.

L'impiego del raddrizzatore tipo **SB** è sempre da prevedere nei casi di:

Use of the **SB** rectifier is mandatory in the event of:

Der Einsatz eines Gleichrichters vom Typ **SB** wird in folgenden Fällen empfohlen:

L'utilisation du redresseur type **SB** doit toujours être prévue dans les cas suivants :

- elevato numero di interventi orari
- tempi di sblocco freno ridotti
- elevate sollecitazioni termiche del freno

- high number of operations per hour
- reduced brake release response time
- brake is exposed to extreme thermal stress

- hohe Anzahl von Schaltungen pro Stunde
- schnelle Bremsansprechzeiten
- starke thermische Beanspruchungen der Bremse

- nombre d'interventions horaires élevé
- temps de déblocage frein réduits
- sollicitations thermiques du frein élevées

Per applicazioni dove è richiesto un rapido rilascio del freno sono disponibili a richiesta i raddrizzatori **NBR** o **SBR**. Questi raddrizzatori completano i tipi **NB** e **SB**, integrando nel cir-

Rectifiers **NBR** or **SBR** are available for applications requiring quick brake release response. These rectifiers complement the **NB** and **SB** types as their elec-

Für die Anwendungen, bei denen eine schnelle Ansprechzeit der Bremse gefordert wird, können auf Anfrage die Gleichrichter **NBR** oder **SBR** geliefert werden. Diese Gleichrichter erweitern die

Pour les applications nécessitant un déblocage rapide du frein, sur demande les redresseurs **NBR** ou **SBR** sont disponibles. Ces redresseurs complètent les types **NB** et **SB**, en intégrant

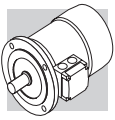

cuito elettronico un interruttore statico che interviene diseccando rapidamente il freno in caso di mancanza di tensione. Questa soluzione consente di ridurre i tempi di rilascio del freno evitando ulteriori cablaggi e contatti esterni. Per il migliore utilizzo dei raddrizzatori **NBR** e **SBR** è richiesta l'alimentazione separata del freno. Tensioni disponibili: 230V \pm 10%, 400V \pm 10%, 50/60 Hz.

*tronic circuit incorporates a static switch that de-energizes the brake quickly in the event voltage is missing. This arrangement ensures short brake release response time with no need for additional external wiring and contacts. Optimum performance of rectifiers **NBR** and **SBR** is achieved with separate brake power supply. Available voltages: 230V \pm 10%, 400V \pm 10%, 50/60 Hz.*

Funktion der Typen **NB** und **SB**, indem in dem elektronischen Schaltkreis ein statischen Schalter integriert ist, durch dessen Auslösen die Bremse im Fall eines Spannungsausfalls schnell abgeregelt wird. Diese Lösung ermöglicht eine Verringerung der Ansprechzeiten der Bremse, wodurch weitere Schaltungen und externe Sensoren vermieden werden können. Im Hinblick auf einen besseren Einsatz der Gleichrichter **NBR** und **SBR** ist bei der Bremse eine separate Versorgung erforderlich. Verfügbare Spannungen: 230V \pm 10%, 400V \pm 10%, 50/60 Hz.

*dans le circuit électronique un interrupteur statique qui intervient en désexcitant rapidement le frein en cas de coupure de tension. Cette solution permet de réduire les temps de déblocage du frein en évitant d'autres câblages et contacts extérieurs. Pour une meilleure utilisation des redresseurs **NBR** et **SBR** l'alimentation séparée du frein est nécessaire. Tensions disponibles : 230V \pm 10%, 400V \pm 10%, 50/60 Hz.*

Dati tecnici freni FD

Nella tabella (A54) sottostante sono riportati i dati tecnici dei freni in c.c. tipo FD.

(A54)

FD brake technical specifications

The table (A54) below reports the technical specifications of DC brakes FD.

Technische Daten - Bremstyp FD

In der nachstehenden Tabelle (A54) werden die technischen Daten der Gleichstrombremsen vom Typ FD angegeben.

Caractéristiques techniques freins FD

Le tableau (A54) suivant indique les caractéristiques techniques des freins en c.c. type FD.

Freno Brake Bremse Frein	Coppia frenante M_b [Nm] Brake torque M_b [Nm] Bremsmoment M_b [Nm] Couple de freinage M_b [Nm]			Rilascio Release Ansprchzeit Déblocage		Frenatura Braking Bremsung Freinage		Wmax per frenata Wmax per brake operation Wmax pro Bremsung Wmax par freinage			W	P
	molle / springs feder / ressorts			t_1	t_{1s}	t_2	t_{2c}	[J]				
	6	4	2	[ms]	[ms]	[ms]	[ms]	10 s/h	100 s/h	1000 s/h		
FD02	—	3.5	1.75	30	15	80	9	4500	1400	180	15	17
FD03	5	3.5	1.75	50	20	100	12	7000	1900	230	25	24
FD53	7.5	5	2.5	60	30	100	12					
FD04	15	10	5	80	35	140	15	10000	3100	350	30	33
FD14												
FD05	40	26	13	130	65	170	20	18000	4500	500	50	45
FD15	40	26	13	130	65	170	20					
FD55	55	37	18	—	65	170	20					
FD06S	60	40	20	—	80	220	25	20000	4800	550	70	55
FD56	—	75	37	—	90	150	20	29000	7400	800	80	65
FD06		100	50		100	150	20					
FD07	150	100	50	—	120	200	25	40000	9300	1000	130	65
FD08*	250	200	170	—	140	350	30	60000	14000	1500	230	100
FD09**	400	300	200	—	200	450	40	70000	15000	1700	230	120

* valori di coppia frenante ottenuti con n° 9, 7, 6 molle rispettivamente

* brake torque values obtained with 9, 7 and 6 springs, respectively

* Werte, der durch den Einsatz von jeweils 9, 7, 6 Federn erreichten Bremsmomente

* valeurs de couple de freinage obtenues respectivement avec n° 9, 7, 6 ressorts

** valori di coppia frenante ottenuti con n° 12, 9, 6 molle rispettivamente

** brake torque values obtained with 12, 9 and 6 springs, respectively

** Werte, der durch den Einsatz von jeweils 12, 9, 6 Federn erreichten Bremsmomente

** valeurs de couple de freinage obtenues respectivement avec n° 12, 9, 6 ressorts

Legenda:

t_1 = tempo di rilascio del freno con alimentatore a semionda
 t_{1s} = tempo di rilascio del freno con alimentatore a controllo elettronico dell'eccitazione
 t_2 = ritardo di frenatura con interruzione lato c.a. e alimentazione separata
 t_{2c} = ritardo di frenatura con interruzione lato c.a.e c.c. — I valori di t_1 , t_{1s} , t_2 , t_{2c} indicati nella tab. (A54) sono riferiti al freno tarato alla coppia massima, trafero medio e tensione nominale
 W_{max} = energia max per frenata
 W = energia di frenatura tra due regolazioni successive del trafero
 P_b = potenza assorbita dal freno a 20°C
 M_b = coppia frenante statica ($\pm 15\%$)
 s/h = avviamenti orari

Key:

t_1 = brake release time with half-wave rectifier
 t_{1s} = brake release time with over-energizing rectifier
 t_2 = brake engagement time with AC line interruption and separate power supply
 t_{2c} = brake engagement time with AC and DC line interruption — Values for t_1 , t_{1s} , t_2 , t_{2c} indicated in the tab. (A54) are referred to brake set at maximum torque, medium air gap and rated voltage
 W_{max} = max energy per brake operation
 W = braking energy between two successive air gap adjustments
 P_b = brake power absorption at 20 °C
 M_b = static braking torque ($\pm 15\%$)
 s/h = starts per hour

Zeichenerklärung:

t_1 = Ansprechzeit der Bremse mit Halbwellegleichrichter
 t_{1s} = Ansprechzeit der Bremse mit elektronisch gesteuerten Erregungsgleichrichter
 t_2 = Bremsverzögerung mit Unterbrechung auf Wechselstromseite und Fremdversorgung
 t_{2c} = Bremsverzögerung mit Unterbrechung auf Wechselstrom- und Gleichstromseite — Die in der Tab. (A54) angegebenen Werte t_1 , t_{1s} , t_2 , t_{2c} beziehen sich auf eine auf das max. Bremsmoment geeichte Bremse, mit mittlerem Luftspalt und Nennspannung
 W_{max} = max. Energie pro Bremsung
 W = Bremsenergie zwischen zwei Einstellungen des Luftspalts
 P_b = bei 20 ° C von der Bremse aufgenommene Leistung (50 Hz)
 M_b = statisches Bremsmoment ($\pm 15\%$)
 s/h = Einschaltungen pro stunde

Légende:

t_1 = temps de déblocage du frein avec dispositif d'alimentation à demi-onde
 t_{1s} = temps de déblocage du frein avec dispositif d'alimentation à contrôle électronique de l'excitation
 t_2 = retard de freinage avec interruption côté c.a. et alimentation séparée
 t_{2c} = retard de freinage avec interruption côté c.a. et c.c. — Les valeurs de t_1 , t_{1s} , t_2 , t_{2c} indiquées dans le tab. (A54) se réfèrent au frein étaloné au couple maximal, entrefer moyen et tension nominale
 W_{max} = énergie max. par freinage
 W = énergie de freinage entre deux réglages successifs de l'entrefer
 P_b = puissance absorbée par le frein à 20 °C
 M_b = couple de freinage statique ($\pm 15\%$)
 s/h = démarrages horaires

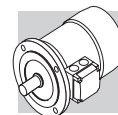

Collegamenti freno FD

I motori standard ad una velocità sono forniti con il collegamento del raddrizzatore alla morsetteria motore già realizzato in fabbrica. Per motori a 2 velocità, e dove è richiesta l'alimentazione del freno separata, prevedere il collegamento al raddrizzatore in accordo alla tensione freno V_B indicata nella targhetta del motore. **Data la natura induttiva del carico, per il comando del freno e per l'interruzione lato corrente continua devono essere utilizzati contatti con categoria d'impiego AC-3 secondo IEC 60947-4-1.**

Tabella (A55) - Alimentazione freno dai morsetti motore ed interruzione lato a.c.

Tempo di arresto t_2 ritardato e funzione delle costanti di tempo del motore. Da prevedere quando sono richiesti avviamenti/arresti progressivi.

Tabella (A56) - Bobina freno con alimentazione separata ed interruzione lato c.a.

Tempo di arresto normale ed indipendente dal motore. Si realizzano i tempi di arresto t_2 indicati nella tabella (A54).

Tabella (A57) - Bobina freno con alimentazione dai morsetti motore ed interruzione lato c.a. e c.c.

Arresto rapido con i tempi d'intervento t_{2c} indicati in tabella (A54).

(A55)

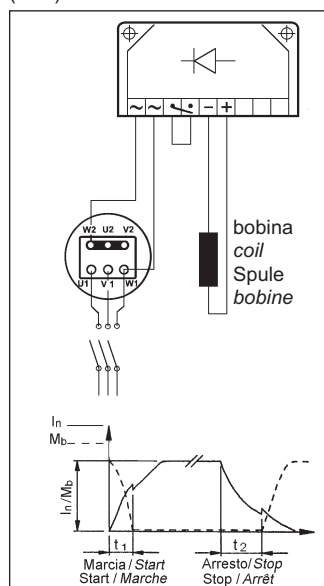

Le tabelle da (A55) a (A58) riportano gli schemi tipici di collegamento per alimentazione 400 V, motori 230/400V collegati a stella e freno 230 V.

FD brake connections

On standard single-pole motors, the rectifier is connected to the motor terminal board at the factory.

For switch-pole motors and where a separate brake power supply is required, connection to rectifier must comply with brake voltage V_B stated in motor name plate.

Because the load is of the inductive type, brake control and DC line interruption must use contacts from the usage class AC-3 to IEC 60947-4-1.

Table (A55) – Brake power supply from motor terminals and AC line interruption

Delayed stop time t_2 and function of motor time constants. Mandatory when soft-start/stops are required.

Table (A56) – Brake coil with separate power supply and AC line interruption

Normal stop time independent of motor. Achieved stop times t_2 are indicated in the table (A54).

Table (A57) – Brake coil power supply from motor terminals and AC/DC line interruption.

Quick stop with operation times t_{2c} as per table (A54).

Table (A58) – Brake coil with separate power supply and AC/DC line interruption.

Stop time decreases by values t_{2c} indicated in the table (A54).

(A56)

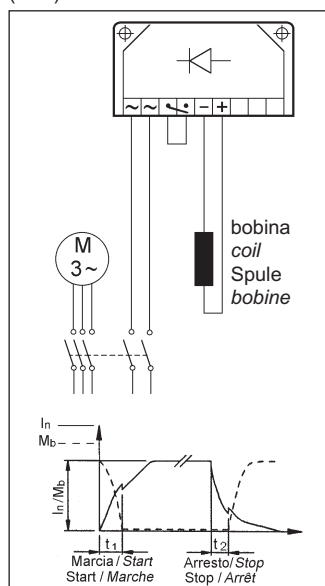

Tables (A55) through (A58) show the typical connection diagrams for 400 V power supply, star-connected 230/400V motors and 230 V brake.

Anschlüsse - Bremstyp FD

Die einpoligen Motoren werden vom Werk ab mit an die Motorspannung angeschlossenem Gleichrichter geliefert.

Für die polumschaltbaren Motoren, und Bremse mit separater Versorgung, wird in Übereinstimmung mit der auf dem Typenschild des Motors angegebenen Bremsspannung V_B der Anschluss an den Gleichrichter vorgesehen.

Da es sich bei der Bremsleistung um eine induktive Kraft handelt, müssen gemäß IEC 60947-4-1 für die Steuerung der Bremse und die Unterbrechung der Gleichstromseite Kontakte der Kategorie AC-3 verwendet werden.

Tabelle (A55) – Bremsversorgung über die Motorspannung und Unterbrechung der Wechselstromseite.

Verzögerter und von den Zeitkonstanten des Motors abhängige Haltezeit t_2 . Vorzusehen, wenn progressive Starts/Stops erforderlich sind.

Tabelle (A56) – Bremsspule mit separater Spannungsversorgung und Unterbrechung der Wechselstromseite.

Normale und vom Motor unabhängige Stoppzeiten. Es werden die in der Tabelle (A54) angegebenen Stoppzeiten t_2 realisiert.

Tabelle (A57) – Bremsspule mit Versorgung über die Motorspannung und Unterbrechung der Gleich- und der Wechselstromseite.

Schneller Stopp mit den in der Tabelle (A54) angegebenen Ansprechzeiten t_{2c} .

Tabelle (A58) - Bremsspule mit separater Spannungsversorgung und Unterbrechung der Gleich- und der Wechselstromseite.

Reduzierte Stoppzeiten der in der Tabelle (A54) angegebenen Werte t_{2c} .

(A57)

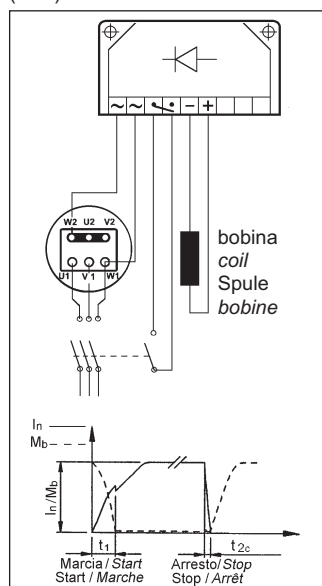

In den Tabellen (A55) bis (A58) werden die typischen Schaltungen für Versorgung mit 400 V, Motoren 230/400V mit Sternschaltung und einer Bremsspannung von 230 V wiedergegeben.

Raccordements frein FD

Les moteurs standard à une vitesse sont fournis avec le raccordement du redresseur au bornier moteur déjà réalisé en usine.

Pour les moteurs à 2 vitesses, et lorsqu'une alimentation séparée du frein est requise, prévoir le raccordement au redresseur conformément à la tension frein V_B indiquée sur la plaque signalétique du moteur.

Etant donné la nature inductive de la charge, pour la commande du frein et l'interruption côté courant continu, il est nécessaire d'utiliser des contacts avec catégorie d'utilisation AC-3 selon la norme IEC 60947-4-1.

Tableau (A55) - Alimentation frein depuis bornes moteur et interruption côté c.a.

Temps d'arrêt t_2 retardé et fonction des constantes de temps du moteur. A prévoir lorsque des démarrages/arrests progressifs sont requis.

Tableau (A56) - Bobine de frein avec alimentation séparée et interruption côté c.a.

Temps d'arrêt normal et indépendant du moteur. Les temps d'arrêts t_2 sont ceux indiqués dans le tableau (A54).

Tableau (A57) - Bobine de frein avec alimentation depuis les bornes moteur et interruption côté c.a. et c.c.

Arrêt rapide avec les temps d'intervention t_{2c} indiqués dans le tableau (A54).

Tableau (A58) - Bobine de frein avec alimentation séparée et interruption côté c.a. et c.c.

Temps d'arrêt réduit selon les valeurs t_{2c} indiquées dans le tableau (A54).

(A58)

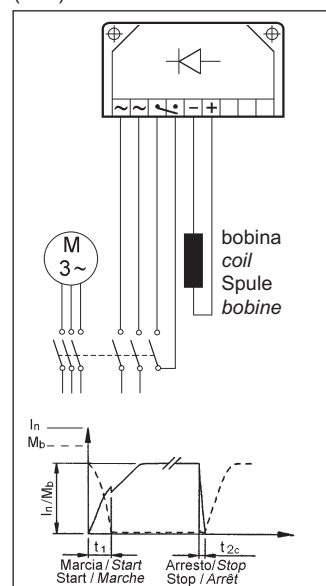

Les tableaux de (A55) à (A58) indiquent les schémas typiques de branchement pour une alimentation de 400 V, moteurs 230/400V raccordés en étoile et frein 230 V.

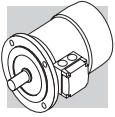

**M7 - MOTORI AUTOFRENANTI
IN C.A., TIPO BN_FA**

**M7 - AC BRAKE MOTORS
TYPE BN_FA**

**M7 - WECHSELSTROM-
BREMSMOTOREN-TYP
BN_FA**

**M7 - MOTEURS FREIN EN C.A.,
TYPE BN_FA**

Grandezze: BN 63 ... BN 180M

Frame sizes: BN 63 ... BN 180M

Baugrößen: BN 63 ... BN 180M

Tailles : BN 63 ... BN 180M

(A59)

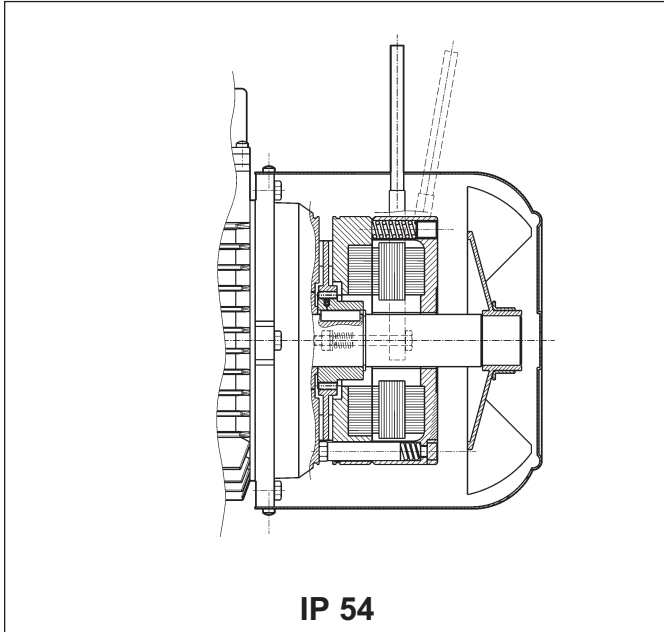

(A60)

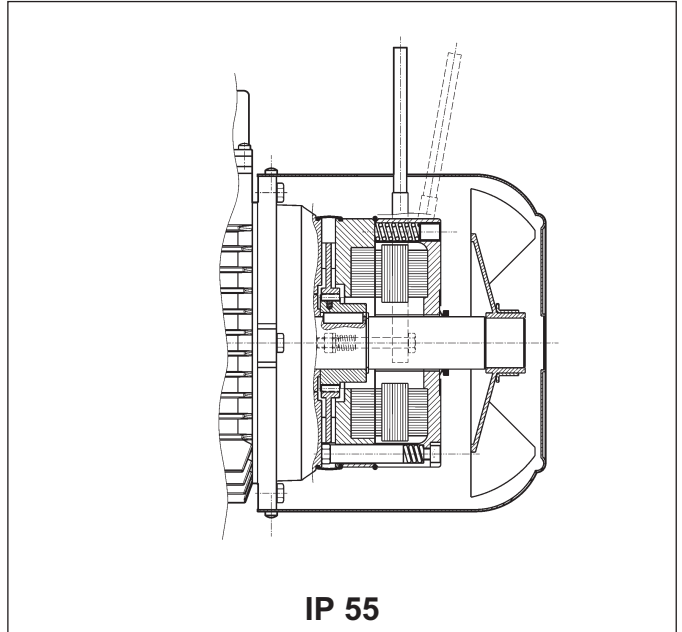

Freno elettromagnetico con alimentazione in **corrente alternata** trifase, fissato con viti allo scudo motore; le molle di precarico realizzano il posizionamento assiale del corpo magnete.

Il disco freno è scorrevole assialmente sul mozzo trascinato in acciaio calettato sull'albero e provvisto di molla antivibrazione. La coppia frenante è pre-impostata in fabbrica su valori che sono indicati nelle tabelle dati tecnici dei relativi motori.

L'azione del freno è inoltre modulabile, regolando con continuità la coppia frenante, tramite le viti che realizzano il precarico delle molle; il campo di regolazione della coppia è: $30\% M_{bMAX} < M_b < M_{bMAX}$ (M_{bMAX} è il momento frenante max riportato in tab. (A62)).

Il freno tipo FA presenta dinamiche molto elevate che lo rendono idoneo in applicazioni dove sono richieste frequenze di avviamento elevate con tempi d'intervento molto rapidi.

A richiesta, i motori possono essere previsti di leva per lo sblocco manuale con ritorno automatico (R). Per la specifica della posizione angolare della leva vedi relativa variante alla pag. 366.

*Electromagnetic brake operates from three-phase **alternated current** power supply and is bolted onto conveyor shield. Preloading springs provide axial positioning of magnet body.*

Steel brake disc slides axially on steel hub shrunk onto motor shaft with anti-vibration spring. Brake torque factory setting is indicated in the corresponding motor rating charts.

Spring preloading screws provide stepless braking torque adjustment.

Torque adjustment range is $30\% M_{bMAX} < M_b < M_{bMAX}$ (where M_{bMAX} is maximum braking torque as shown in tab. (A62)).

Thanks to their high dynamic characteristics, FA brakes are ideal for heavy-duty applications as well as applications requiring frequent stop/starts and very fast response time.

Motors may be equipped with manual release lever with automatic return (R) at request. See variants at page 366 for available lever locations.

Elektromagnetische Bremse mit **Drehstromversorgung**, die mittels Schrauben am hinteren Motorschild befestigt ist. Die Federn sorgen dabei für die axiale Ausrichtung des Magnetkörpers.

Die Bremsscheibe (Stahl) gleitet axial auf dem sich auf dem Rotor befindlichen Mitnehmer, der über eine Paßfeder mit Motorwelle verbunden und mit einer Schwingungsdämpffeder ausgestattet ist.

Das Bremsmoment wird auf das entsprechende Motormoment eingestellt (siehe Tabelle der technischen Daten der entsprechenden Motoren).

Das Bremsmoment ist stufenlos durch über die Schrauben die die Federvorspannung einstellbar. Der Einstellbereich beträgt $30\% M_{bMAX} < M_b < M_{bMAX}$ (M_{bMAX} steht für den max. Bremsmoment, der in der Tab (A62) angegeben wird).

Die Bremse vom Typ FA zeichnet sich durch ihre hohen Dynamik aus, weshalb sie für Anwendungen geeignet sind, in denen hohe Schaltfrequenzen und schnelle Ansprechzeiten gefordert werden.

Auf Anfrage können die Motoren mit einem Lüfterhebel für die manuelle Lüftung der Bremse mit automatischer Rückstellung (R) geliefert werden. Die Angabe der Montageposition erfolgt über die Angabe der Option auf Seite 366.

*Frein électromagnétique avec alimentation en **courant alternatif** triphasé, fixé avec des vis au bouclier; les ressorts de précharge réalisent le positionnement axial de la bobine.*

Le disque frein coulisse de façon axiale sur le moyeu d'entraînement en acier, calé sur l'arbre et doté de ressort antivibration.

Le couple de freinage est pré-réglé en usine aux valeurs qui sont indiquées dans les tableaux des caractéristiques techniques des moteurs correspondants.

De plus, l'action du frein est modulable, en réglant le couple de freinage en continu au moyen des vis qui réalisent la précharge des ressorts; la plage de réglage du couple est de $30\% M_{bMAX} < M_b < M_{bMAX}$ (M_{bMAX} est le couple de freinage maximum indiqué dans le tab. (A62)).

Le frein type FA présente des caractéristiques dynamiques très élevées, il est donc adapté pour des applications nécessitant des fréquences de démarrage élevées et des temps d'intervention très rapides.

Sur demande, les moteurs peuvent être prévus avec levier pour le déblocage manuel avec retour automatique (R). Pour la spécification de la position angulaire du levier, voir variante page 366.

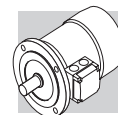

Grado di protezione

L'esecuzione standard prevede il grado di protezione IP54. In opzione, il motore autofrenante BN_FA viene fornito con grado di protezione **IP 55** prevedendo le seguenti varianti costruttive:

- anello V-ring posizionato sull'albero motore NDE.
- fascia di protezione in gomma
- anello O-ring

Degree of protection

Standard protection class is IP54. Brake motor BN_FA is also available in protection class **IP 55**, which mandates the following variants:

- V-ring at N.D.E. of motor shaft
- rubber protection sleeve
- O-ring

Schutzart

Die Standardausführung ist Schutzart IP54 vor. Optional kann der Bremsmotor BN_FA auch in der Schutzart **IP 55** geliefert werden, was durch die folgenden zusätzlichen Bauteile erreicht wird:

- V-Ring an der Motorwelle N.D.E.
- Schutzring aus Gummi
- O-Ring

Degré de protection

L'exécution standard prévoit le degré de protection IP54. En option, le moteur frein BN_FA est fourni avec degré de protection **IP 55**, les variations de construction suivantes sont prévues :

- bague V-ring positionné sur l'arbre moteur N.D.E.
- bande de protection en caoutchouc
- joint torique

Alimentazione freno FA

Nei motori a singola polarità l'alimentazione della bobina freno è derivata direttamente dalla morsettiera motore e la tensione del freno quindi coincide con la tensione del motore. In questo caso la tensione del freno può essere omessa dalla designazione

Per i motori a doppia polarità, e per i motori con alimentazione separata del freno, è presente una morsettiera ausiliaria con 6 terminali per il collegamento alla linea del freno. In entrambi i casi il valore di tensione del freno dovrà essere specificato in designazione.

Nella tabella seguente sono riportate le condizioni di alimentazione standard del freno in c.a. per i motori a singola e doppia polarità:

FA brake power supply

In single speed motors, power supply is brought to the brake coil direct from the motor terminal box. As a result, brake voltage and motor voltage are the same. In this case, brake voltage indication may be omitted in the designation.

Switch-pole motors and motors with separate brake power supply feature an auxiliary terminal board with 6 terminals for connection to brake line. In both cases, brake voltage indication in the designation is mandatory. The following table reports standard AC brake power supply ratings for single- and switch-pole motors:

Stromversorgung - Bremstyp FA

Bei den einpoligen Motoren wird die Versorgung der Bremsspule direkt vom Motorklemmenkasten abgenommen, das bedeutet, dass die Spannung der Bremse mit der Motorspannung übereinstimmt. In diesem Fall braucht die Bremsenspannung nicht extra angegeben werden.

Für die polumschaltbaren Motoren und für eine separate Bremsversorgung ist eine Hilfsklemmenleiste mit 6 Anschlüssen vorgesehen, die einen Anschluß der Bremse ermöglichen. In beiden Fällen muss die Bremsenspannung in der Bestellung angegeben werden.

In der nachstehenden Tabelle werden für die einpoligen und die polumschaltbaren Motoren die Standardspannungen der Wechselstrombremsen angegeben.

Alimentation frein FA

Sur les moteurs à simple polarité, l'alimentation de la bobine frein dérive directement du bornier moteur, par conséquent, la tension du frein coïncide avec la tension du moteur. Dans ce cas, la tension du frein peut être omise de la désignation.

Pour les moteurs à double polarité et les moteurs avec alimentation séparée du frein, une boîte à bornes auxiliaire avec 6 bornes pour le raccordement à la ligne du frein, est présente. Dans les deux cas, la valeur de tension du frein doit être spécifiée dans la désignation.

Le tableau suivant indique les conditions d'alimentation standard du frein en c.a. pour les moteurs à simple et double polarité :

(A61)

motori a singola polarità <i>single-pole motor</i> Einpolige Motoren <i>Moteurs à simple polarité</i>	BN 63...BN 132	BN 160...BN 180
	M05...M4LB	M4LC...M5
	230Δ / 400Y V ±10% – 50 Hz	400Δ/ 690Y V ±10% – 50 Hz
	265Δ / 460Y ±10% - 60 Hz	460Y – 60 Hz

motori a doppia polarità (alimentazione da linea separata) <i>switch-pole motors (separate power supply line)</i> Polumschaltbare Motoren (separate Versorgung) <i>Moteurs à double polarité (alimentation depuis ligne séparée)</i>	BN 63...BN 132
	M05...M4
	230Δ / 400Y V ±10% – 50 Hz
	460Y - 60 Hz

Se non diversamente specificato, l'alimentazione standard del freno è 230Δ /400Y V - 50 Hz.

Unless otherwise specified, standard brake power supply is 230Δ /400Y V - 50 Hz.

Falls nicht anderweitig angegeben, beträgt die Standardversorgung der Bremse 230Δ /400Y V - 50 Hz.

Sauf spécification contraire, l'alimentation standard du frein est 230Δ /400Y V - 50 Hz.

Su richiesta, sono disponibili tensioni speciali, nel campo 24...690 V, 50-60 Hz.

Special voltages in the 24...690 V, 50-60 Hz range are available at request.

Auf Anfrage können Sonderspannungen von 24...690 V, 50-60 Hz geliefert werden.

Sur demande, des tensions spéciales sont disponibles dans la plage 24...690 V, 50-60 Hz.

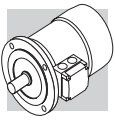

Dati tecnici freni FA

Technical specifications of FA brakes

Technische Daten der Bremsen vom Typ FA

Caractéristiques techniques freins FA

(A62)

Freno Brake Bremse Frein	Coppia frenante Brake torque Bremsmoment Couple de freinage M _b [Nm]	Rilascio Release Ansprechzeit Déblocage t ₁ [ms]	Frenatura Braking Bremsung Freinage t ₂ [ms]	W _{max}			W [MJ]	P _b [VA]
				10 s/h	100 s/h	1000 s/h		
FA 02	3.5	4	20	4500	1400	180	15	60
FA 03	7.5	4	40	7000	1900	230	25	80
FA 04	15	6	60	10000	3100	350	30	110
FA 14								
FA 05	40	8	90	18000	4500	500	50	250
FA 15								
FA 06S	60	16	120	20000	4800	550	70	470
FA 06	75	16	140	29000	7400	800	80	550
FA 07	150	16	180	40000	9300	1000	130	600
FA 08	250	20	200	60000	14000	1500	230	1200

Legenda:

M_b = max coppia frenante statica (±15%)
 t₁ = tempo di rilascio freno
 t₂ = ritardo di frenatura
 W_{max} = energia max per frenata (capacità termica del freno)
 W = energia di frenatura tra due regolazioni successive del traferro
 P_b = potenza assorbita dal freno a 20° (50 Hz)
 s/h = avviamenti orari

Key:

M_b = max static braking torque (±15%)
 t₁ = brake release time
 t₂ = brake engagement time
 W_{max} = max energy per brake operation (brake thermal capacity)
 W = braking energy between two successive air gap adjustments
 P_b = power drawn by brake at 20° (50 Hz)
 s/h = starts per hour

Legende:

M_b = statisches max. Bremsmoment (±15%)
 t₁ = Bremsenansprechzeit
 t₂ = Bremsverzögerung
 W_{max} = max. Energie pro Bremsung (Wärmeleistung der Bremse)
 W = Bremsenergie zwischen zwei Einstellungen des Luftspalts
 P_b = bei 20° von der Bremse aufgenommene Leistung (50 Hz)
 s/h = Einschaltungen pro stunde

Légende:

M_b = couple de freinage statique max (±15%)
 t₁ = temps de déblocage frein
 t₂ = retard de freinage
 W_{max} = énergie max par freinage (capacité thermique du frein)
 W = énergie de freinage entre deux réglages successifs de l'entrefer
 P_b = puissance absorbée par le frein à 20° (50 Hz)
 s/h = démarrages horaires

N.B.

I valori di t₁ e t₂ riportati in tabella sono riferiti al freno tarato alla coppia nominale, traferro medio e tensione nominale.

NOTE

Values t₁ and t₂ in the table refer to a brake set at rated torque, medium air gap and rated voltage.

HINWEIS:

Die in der Tabelle angegebenen Werte t₁ und t₂ beziehen sich auf eine Bremse, die auf das Nenndrehmoment, einen mittleren Luftspalt und die Standardspannung eingestellt ist.

N.B.

Les valeurs de t₁ et t₂ indiquées dans le tableau se réfèrent au frein étalonné au couple nominal, entrefer moyen et tension nominale.

Collegamenti freno FA

FA brake connections

Abschlüsse - Bremstyp FA

Raccordements frein FA

Per i motori con alimentazione del freno derivata direttamente dall'alimentazione motore i collegamenti alla morsettiera corrispondono a quanto riportato nello schema (A63):

The diagram (A63) shows the wiring when brake is connected directly to same power supply of the motor:

Bei den Motoren mit direkter Bremsspannungsversorgung müssen die Anschlüsse im Klemmenkasten entsprechend den Angaben im Schema (A63) angeschlossen werden:

Pour les moteurs avec alimentation du frein dérivant directement de l'alimentation moteur, les raccordements à la boîte à bornes correspondent aux indications du schéma (A63) :

(A63)

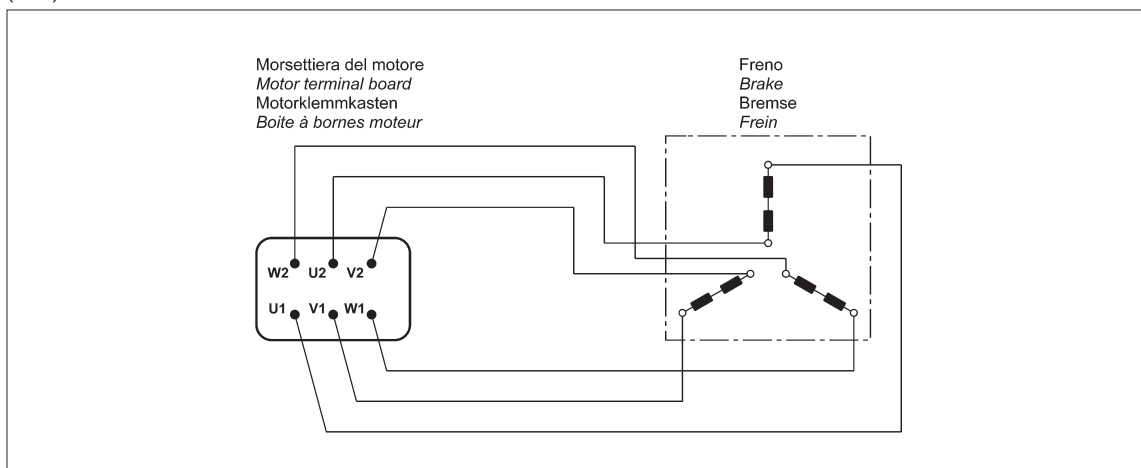

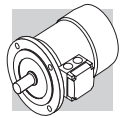

Per i motori a doppia polarità e, quando richiesto, per i motori ad una velocità con alimentazione da linea separata è prevista una morsettiera ausiliaria a 6 morsetti per il collegamento del freno; in questa esecuzione i motori prevedono la scatola copri-morsetti maggiorata. Vedi schema (A64):

Switch-pole motors and, at request, single-pole motors with separate power supply are equipped with an auxiliary terminal board with 6 terminals for brake connection.

In this version, motors feature a larger terminal box. See diagram (A64):

Bei den polumschaltbaren Motoren und, auf Anfrage, auch bei den einpoligen Motoren mit separater Bremsversorgung ist für den Anschluss der Bremse ein Hilfsklemmenkasten mit 6 Klemmen vorgesehen. In diesen Ausführungen haben die Motoren einen größeren Klemmenkasten. Siehe Schema (A64):

Pour les moteurs à double polarité et, lorsque cela est requis, pour les moteurs à une vitesse avec alimentation depuis ligne séparée, une boîte à bornes auxiliaire à 6 bornes est prévue pour le raccordement du frein ; dans cette exécution les moteurs prévoient un couvercle bornier majoré. Voir schéma (A64) :

(A64)

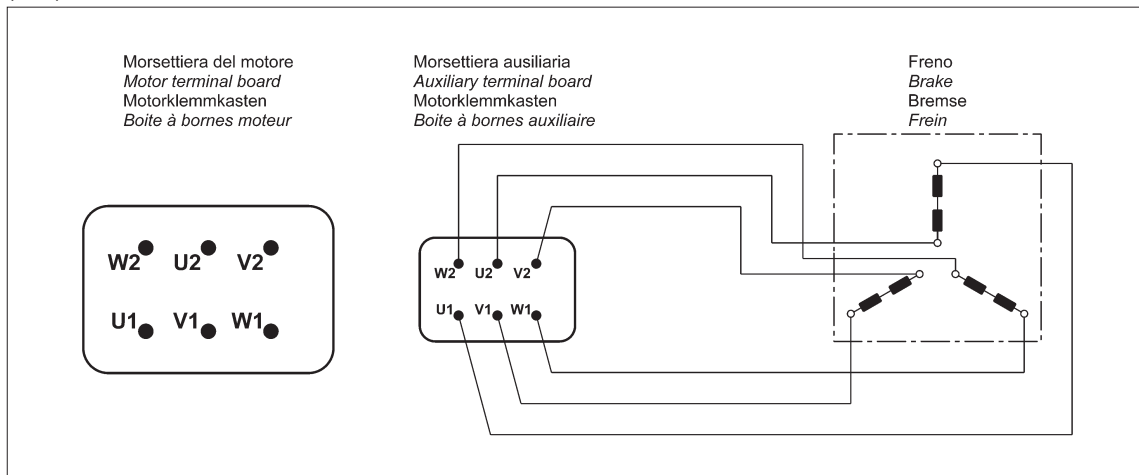

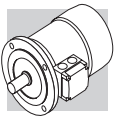

**M8 - MOTORI AUTOFRENANTI
IN C.A., TIPO BN_BA**

**M8 - AC BRAKE MOTORS
TYPE BN_BA**

**M8 - DREHSTROM-BREMS-
MOTOREN MIT WECH-
SELS-TROMBREMSE
VOM TYP BN_BA**

**M8 - MOTEURS FREIN EN C.A.,
TYPE BN_BA**

Grandezze: BN 63 ... BN 132M

Frame sizes: BN 63 ... BN 132M

Baugrößen: BN 63 ... BN 132M

Tailles : BN 63 ... BN 132M

(A65)

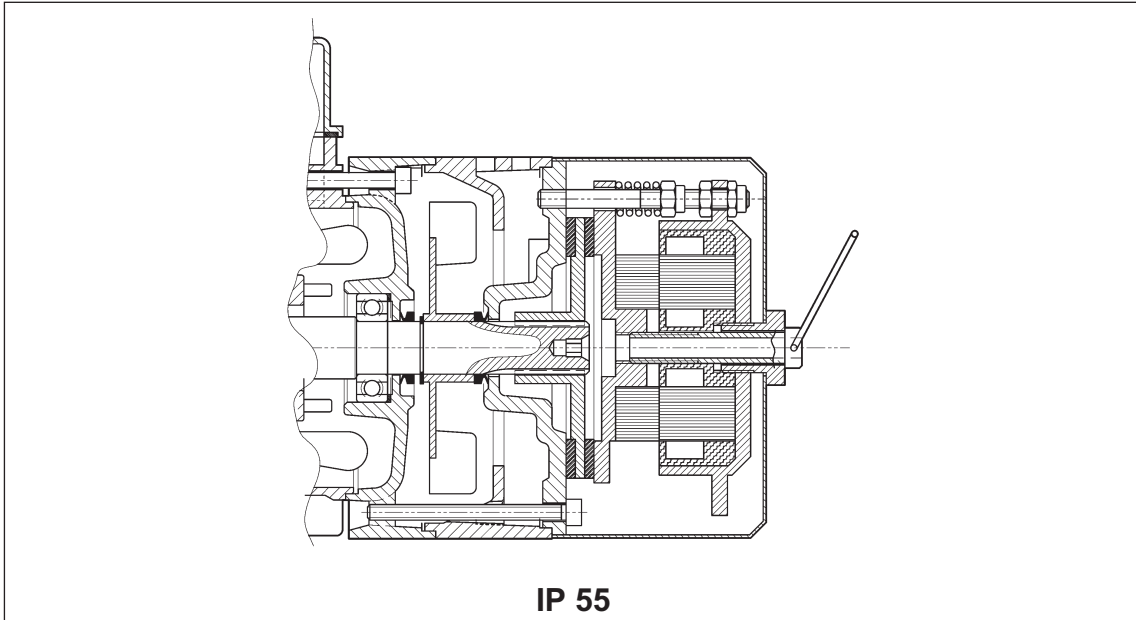

Freno elettromagnetico con alimentazione in **corrente alternata** trifase, fissato con viti allo scudo convogliatore.

Disco freno in acciaio scorrevole assialmente sull'albero motore scanalato (mozzo trascinatore in acciaio calettato sull'albero per grandezza 244).

I motori sono forniti con freno tarato alla massima coppia.

La coppia freno è regolabile con continuità agendo sulle viti di compressione delle molle; il campo di regolazione consentito è $30\% M_{bMAX} < M_b < M_{bMAX}$ (M_{bMAX} è il momento frenante massimo riportato in tab. (A66)). Di serie i motori sono forniti completi di vite per lo sblocco manuale del freno, con mantenimento della posizione di rilascio per consentire la rotazione dell'albero motore.

La vite di sblocco deve essere smontata dopo l'utilizzo per assicurare il corretto funzionamento del freno, ed evitare situazioni potenzialmente pericolose.

Il freno BA, oltre alle elevate caratteristiche dinamiche tipiche dei freni in corrente alternata, presenta una costruzione robusta con energia di frenatura aumentata che lo rendono particolarmente idoneo a servizi pesanti, oltre che in applicazioni dove sono richieste frequenze di manovra elevate e tempi d'intervento molto rapidi.

*Electromagnetic brake operates from three-phase **alternated current** power supply and is bolted onto conveyor shield.*

Steel brake disc slides axially on splined motor shaft (steel drive hub is shrunk onto shaft on frame size 244).

Factory setting is maximum brake torque.

Step less braking torque adjustment by screws which compress the brake springs. Allowed adjustment range is $30\% M_{bMAX} < M_b < M_{bMAX}$ (where M_{bMAX} is maximum braking torque as shown in tab. (A66)).

Motors are supplied complete with manual brake release screw as standard. Screw may be locked in the release position to allow for motor shaft rotation.

The brake release screw must be removed after use to ensure proper brake operation and avoid potentially dangerous conditions.

In addition to the high dynamic characteristics typical of AC brakes, a sturdy design and increased braking energy make the BA brake ideal for heavy-duty applications as well as applications requiring frequent stop/starts and very fast response time.

Elektromagnetische Bremse mit **Drehstromversorgung**, die mittels Schrauben am Motorschild des Motors befestigt ist.

Die Brems Scheibe (Stahl) gleitet axial auf der Rotorwelle (bei Baugröße 244 über einem auf die Welle aufgezogenem Mitnehmer aus Stahl).

Die Motoren werden mit einer auf das maximale Drehmoment des Motors eingestellten Bremse geliefert.

Das Bremsdrehmoment ist durch Betätigen der Federdruckschrauben stufenlos regelbar. Der zulässige Einstellbereich beträgt $30\% M_{bMAX} < M_b < M_{bMAX}$ (M_{bMAX} steht für den max. Bremsmoment, das in der Tab. (A66) angegeben wird).

Die Motoren werden serienmäßig mit einer Schraube zur manuelle Bremslüftung geliefert; die arretierbar ist, um ein Drehen der Motorwelle zu ermöglichen.

Diese Schraube muss im Betrieb des Motors wieder abmontiert werden, damit die korrekte Funktion der Bremse gesichert ist.

Die Bremse vom Typ BA zeichnet sich durch ihre dynamischen Eigenschaften und die robuste Bauweise aus, durch die sie eine erhöhte Bremsenergie abzugeben kann. Diese Bremsen eignen sich besonders für einen Einsatz unter harten Bedingungen und überall dort, wo häufige Schaltfrequenzen und schnelle Ansprechzeiten gefordert werden.

*Frein électromagnétique avec alimentation en **courant alternatif** triphasé, fixé avec des vis au bouclier.*

Disque frein en acier coulissant de façon axiale sur l'arbre moteur rainuré (moyeu d'entraînement en acier calé sur l'arbre pour la taille 244).

Les moteurs sont fournis avec frein étalonné au couple maximal.

Le couple de freinage est réglable en continu en intervenant sur les vis de compression des ressorts; la plage de réglage autorisé est de $30\% M_{bMAX} < M_b < M_{bMAX}$ (M_{bMAX} étant le couple de freinage maximum indiqué dans le tab. (A66)).

De série, les moteurs sont fournis avec vis de déblocage manuel du frein, avec maintien de la position de relâchement afin de permettre la rotation de l'arbre moteur.

La vis de déblocage doit être démontée après utilisation afin de garantir le fonctionnement correct du frein et d'éviter les situations potentiellement dangereuses.

Le frein BA, outre les caractéristiques dynamiques élevées typiques des freins en courant alternatif, est de fabrication robuste avec énergie de freinage majorée, ce qui le rend particulièrement adapté pour les services difficiles ainsi que pour les applications nécessitant des fréquences de manœuvre élevées et des temps d'intervention très rapides.

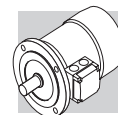

Grado di protezione

È disponibile un'unica esecuzione, con grado di protezione IP55.

Protection class

Only available in protection class IP55.

Schutzart

Es ist eine nur die Ausführung in Schutzklasse IP55 verfügbar.

Degré de protection

Il est disponible en une exécution unique, avec degré de protection IP55.

Alimentazione freno BA

Nei motori a singola polarità l'alimentazione della bobina freno è derivata direttamente dalla morsettiera motore e la tensione del freno quindi coincide con la tensione del motore. In questo caso la tensione del freno può essere omessa dalla designazione.

Per i motori a doppia polarità, e per i motori con alimentazione separata del freno, è presente una morsettiera ausiliaria con 6 terminali per il collegamento alla linea del freno. In entrambi i casi il valore di tensione del freno dovrà essere specificato in designazione.

Nella tabella seguente sono riportate le condizioni di alimentazione standard del freno in c.a. per i motori a singola e doppia polarità:

BA brake power supply

In single speed motors, power supply is brought to the brake coil direct from the motor terminal box. As a result, brake voltage and motor voltage are the same. In this case, brake voltage indication may be omitted in the designation.

Switch-pole motors and motors with separate brake power supply feature an auxiliary terminal board with 6 terminals for connection to brake line. In both cases, brake voltage indication in the designation is mandatory. The following table reports standard AC brake power supply ratings for single- and switch-pole motors:

Stromversorgung - Bremstyp BA

Bei den einpoligen Motoren wird die Versorgung der Bremsspule direkt vom Motorklemmenkasten abgezweigt, das bedeutet also, dass die Spannung der Bremse mit der Motorspannung übereinstimmt. In diesem Fall braucht die Bremsenspannung nicht extra angegeben werden.

Für polumschaltbaren Motoren und für eine separate Bremsversorgung ist eine Hilfsklemmenleiste mit 6 Anschlüssen vorgesehen, die einen Anschluss der Bremse ermöglichen. In beiden Fällen muss die Bremsenspannung bei der Bestellung angegeben werden.

In der nachstehenden Tabelle werden für die einpoligen und die polumschaltbaren Motoren die Standardversorgung der Wechselstrombremsen angegeben.

Alimentation frein BA

Sur les moteurs à simple polarité, l'alimentation de la bobine frein dérive directement du bornier moteur, par conséquent, la tension du frein coïncide avec la tension du moteur. Dans ce cas, la tension du frein peut être omise de la désignation.

Pour les moteurs à double polarité et les moteurs avec alimentation séparée du frein, un boîte à bornes auxiliaire avec 6 bornes pour le raccordement au réseau du frein, est présente. Dans les deux cas, la valeur de tension du frein doit être spécifiée dans la désignation.

Le tableau suivant indique les conditions d'alimentation standard du frein en c.a. pour les moteurs à simple et double polarité :

(A65)

motori a singola polarità single-pole motor Einpolige Motoren Moteurs à simple polarité	BN 63 ... BN 132
	230Δ / 400Y V ±10% – 50 Hz
	265Δ / 460Y ±10% - 60 Hz
motori a doppia polarità (alimentazione da linea separata) switch-pole motors (separate power supply line) Polumschaltbare Motoren (separate Versorgung) Moteurs à double polarité (alimentation depuis ligne séparée)	BN 63 ... BN 132
	230Δ / 400Y V ±10% – 50 Hz
	460Y - 60 Hz

Se non diversamente specificato, l'alimentazione standard del freno è 230Δ / 400Y V - 50 Hz.

Unless otherwise specified, standard brake power supply is 230Δ / 400Y V - 50 Hz.

Falls nicht anderweitig angegeben, beträgt die Standardversorgung der Bremse 230Δ / 400Y V - 50 Hz.

Sauf spécification contraire, l'alimentation standard du frein est 230Δ / 400Y V - 50 Hz.

Su richiesta, sono disponibili tensioni speciali, nel campo 24...690 V, 50-60 Hz.

Special voltages in the 24...690 V, 50-60 Hz range are available at request.

Auf Anfrage können Sonderspannungen von 24...690 V, 50-60 Hz geliefert werden.

Sur demande, des tensions spéciales sont disponibles dans la plage 24...690 V, 50-60 Hz.

Dati tecnici freni BA

Nella tabella (A66) sottostante sono riportati i dati tecnici dei freni in c.a., tipo BA.

BA brake technical specifications

The table (A66) below reports the technical specifications for AC brakes type BA.

Technische Daten der Bremsen vom Typ BA

In der nachstehenden Tabelle (A66) werden die technischen Daten der Wechselstrombremsen vom Typ BA angegeben:

Caractéristiques techniques freins BA

Le tableau (A66) ci-dessous indique les caractéristiques techniques des freins en c.a., type BA.

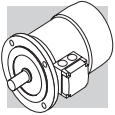

(A66)

Freno Brake Bremsse Frein	Coppia frenante Brake torque Bremsmoment Couple de freinage M_b [Nm]	Rilascio Release Ansprechzeit Déblocage t_1 [ms]	Frenatura Braking Bremsung Freinage t_2 [ms]	W _{max}			W [MJ]	P _b [VA]
				[J]				
				10 s/h	100 s/h	1000 s/h		
BA 60	5	5	20	4000	1500	180	30	60
BA 70	8	6	25	7000	2700	300	60	75
BA 80	18	6	25	10000	3100	350	80	110
BA 90	35	8	35	13000	3600	400	88	185
BA 100	50	8	35	18000	4500	500	112	225
BA 110	75	8	35	28000	6800	750	132	270
BA 140	150	15	60	60000	14000	1500	240	530

Legenda:

M_b = max coppia frenante statica (±15%)

t_1 = tempo di rilascio freno

t_2 = ritardo di frenatura

W_{max} = energia max per frenata (capacità termica del freno)

W = energia di frenatura tra due regolazioni successive del traferro

P_b = potenza assorbita dal freno a 20° (50 Hz)

s/h = avviamenti orari

N.B.

I valori di t_1 e t_2 riportati in tabella sono riferiti al freno tarato alla coppia nominale, traferro medio e tensione nominale.

Key:

M_b = max static braking torque (±15%)

t_1 = brake release time

t_2 = brake engagement time

W_{max} = max energy per brake operation (brake thermal capacity)

W = braking energy between two successive air gap adjustments

P_b = brake power absorption at 20° (50 Hz)

s/h = starts per hour

NOTE

Values t_1 and t_2 in the table refer to a brake set at rated torque, medium air gap and rated voltage.

Legende:

M_b = statisches max. Bremsmoment (±15%)

t_1 = Bremsenansprechzeit

t_2 = Bremsverzögerung

W_{max} = max. Energie pro Bremsung (Wärmeleistung der Bremse)

W = Bremsenergie zwischen zwei Einstellungen des Luftspalts

P_b = bei 20° von der Bremse aufgenommene Leistung (50 Hz)

s/h = Einschaltungen pro stunde

HINWEIS:

Die in der Tabelle angegebenen Werte t_1 und t_2 beziehen sich auf eine Bremse, die auf das Nenn Drehmoment, einen mittleren Luftspalt und die Standardspannung eingestellt ist.

Légende:

M_b = couple de freinage statique max (±15%)

t_1 = temps de déblocage frein

t_2 = retard de freinage

W_{max} = énergie max par freinage (capacité thermique du frein)

W = énergie de freinage entre deux réglages successifs de l'entrefer

P_b = puissance absorbée par le frein à 20° (50 Hz)

s/h = démarrages horaires

N.B.

Les valeurs de t_1 et t_2 indiquées dans le tableau se réfèrent au frein étaloné au couple nominal, entrefer moyen et tension nominale.

Collegamenti freno BA

Per i motori con alimentazione del freno derivata direttamente dall'alimentazione motore i collegamenti alla morsettiera corrispondono a quanto riportato nello schema (A67):

BA brake connections

The diagram (A67) shows the required connections to terminal box when brake is to be connected directly to motor power supply:

Abschlüsse - Bremstyp BA

Bei den Motoren mit direkter Bremsspannungsversorgung müssen die Anschlüsse im Klemmenkasten entsprechend den Angaben im Schema (A67) angeschlossen werden:

Raccordements frein BA

Pour les moteurs avec alimentation du frein dérivant directement de l'alimentation moteur, les raccordements à la boîte à bornes correspondent aux indications du schéma (A67) :

(A67)

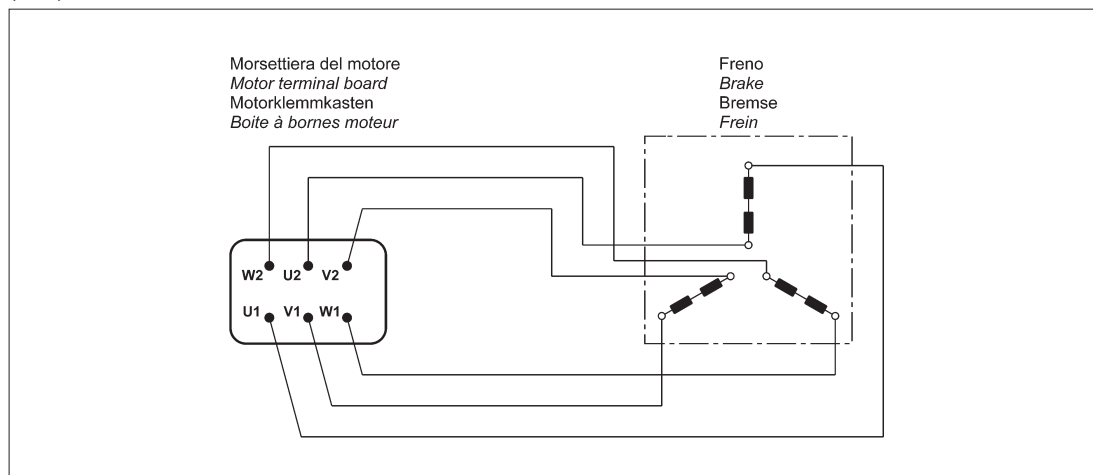

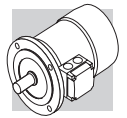

Per i motori a doppia polarità e, quando richiesto, per i motori ad una velocità con alimentazione da linea separata è prevista una morsettiera ausiliaria a 6 morsetti per il collegamento del freno; in questa esecuzione i motori prevedono la scatola coprimorsetti maggiorata. Vedi schema (A68):

Switch-pole motors and, at request, single-pole motors with separate power supply line are equipped with an auxiliary terminal board with 6 terminals for brake connection. In this version, motors feature a larger terminal box. See diagram (A68):

Bei den polumschaltbaren Motoren und, auf Anfrage, auch bei den einpoligen Motoren mit separater Bremsversorgung ist für den Anschluss der Bremse ein Hilfsklemmenkasten mit 6 Klemmen vorgesehen. In diesen Ausführungen haben die Motoren einen größeren Klemmenkasten. Siehe Schema (A68):

Pour les moteurs à double polarité et, lorsque cela est requis, pour les moteurs à une vitesse avec alimentation depuis ligne séparée, une boîte à bornes auxiliaire à 6 bornes est prévue pour le raccordement du frein ; dans cette exécution les moteurs prévoient un couvercle bornier majoré. Voir schéma (A68) :

(A68)

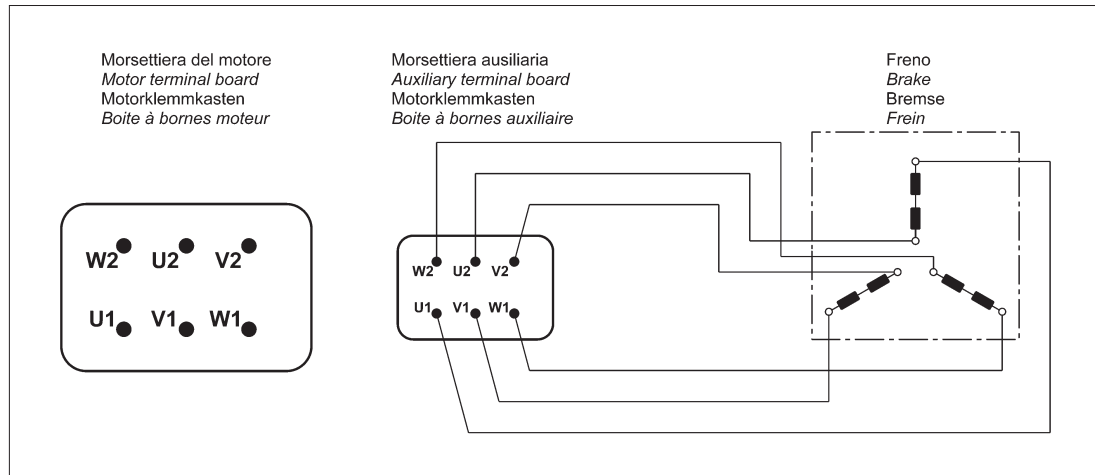

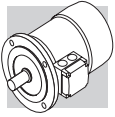

M9 - SISTEMI DI SBLOCCO FRENO

I freni a pressione di molle tipo **FD** e **FA** possono essere dotati opzionalmente di dispositivi per lo sblocco manuale del freno, normalmente utilizzati per condurre interventi di manutenzione sulle parti di macchina, o dell'impianto, comandate dal motore.

M9 - BRAKE RELEASE SYSTEMS

*Spring-applied brakes type **FD** and **FA** may be equipped with optional manual release devices. These are typically used for manually releasing the brake before servicing any machine or plant parts operated by the motor.*

M9 - BREMSLÜFTHEBEL

Die Federdruckbremsen vom Typ **FD** und **FA** können Optional mit Bremslüfthebeln geliefert werden, die ein manuelles Lüften der Bremse ermöglichen. Diese Lüftungseinrichtungen können bei Instandhaltungsarbeiten an vom Motor betriebenen Maschinen- oder Anlagenteilen verwendet werden.

M9 - SYSTEMES DE DEBLOCAGE FREIN

*Les freins à pression de ressorts type **FD** et **FA** peuvent, en option, être dotés de dispositifs de déblocage manuel du frein, normalement utilisés pour effectuer des interventions d'entretien sur les composants de la machine, ou de l'installation commandée par le moteur.*

(A69)

R

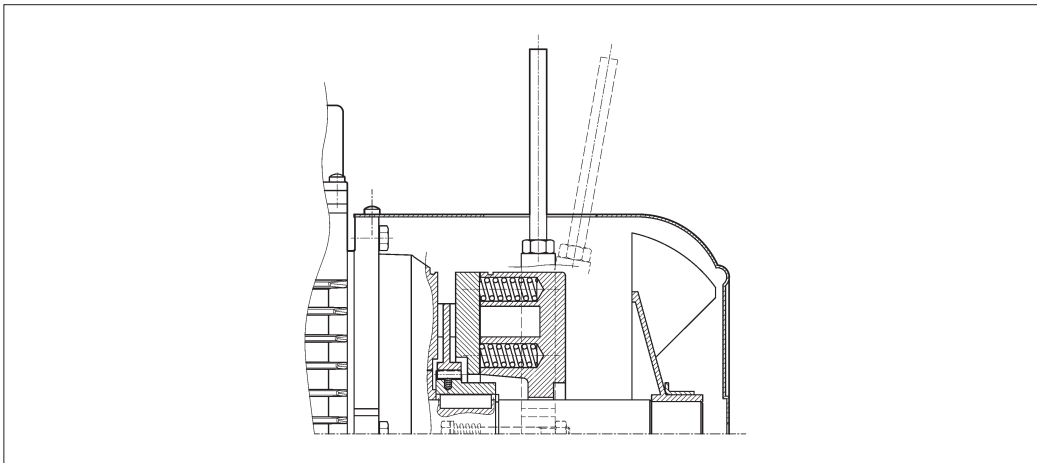

La leva di sblocco è dotata di ritorno automatico, tramite dispositivo a molla.

A return spring brings the release lever back in the original position.

Bremslüfthebel mit automatischer Rückstellung durch Federkraft.

Le levier de déblocage est doté de retour automatique, au moyen d'un dispositif à ressort.

(A70)

RM

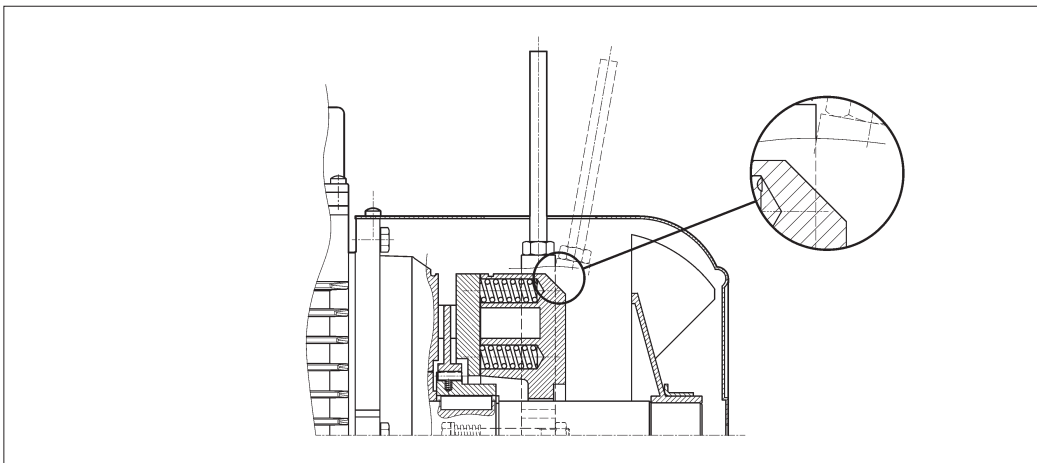

Sui motori tipo **BN_FD** la leva di sblocco può essere temporaneamente bloccata in posizione di rilascio del freno, avvitando la stessa fino ad impegnarne l'estremità in un risalto del corpo del freno.

*On motors type **BN_FD**, if the option **RM** is specified, the release device may be locked in the "release" position by tightening the lever until its end becomes engaged with a brake housing projection.*

Der Bremslüfthebel kann zeitweise in der Bremslüfthebel position arretiert werden, indem man ihn so lange einschraubt, bis die Bremse arretiert ist. Für die unterschiedlichen Motor-

Levier de déblocage peut être temporairement bloqué en position de déblocage du frein en le vissant jusqu'à engager l'extrémité dans une saillie du corps du frein. La disponibilité des systèmes de

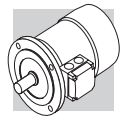

La disponibilità dei sistemi di sblocco freno è diversa per i vari tipi di motore, ed è descritta dalla tabella seguente:

The availability for the various disengagement devices is charted here below:

typen sind ebenso verschiedene Bremslüftsyste me verfügbar, die Sie der folgenden Tabelle entnehmen können:

débloccage du frein est différente en fonction des types de moteur et figure dans le tableau suivant :

(A71)	R	RM
BN_FD	BN 63...BN 200	2p 63A2 ≤ H ≤ 132M2 4p 63A4 ≤ H ≤ 132MA4 6p 63A6 ≤ H ≤ 132MA6
M_FD	M 05...M 5	M 05...M 4LA
BN_FA	BN 63...BN 180M	
M_FA	M 05...M 5	
BN_BA	<p>di serie std. supply serienmäßig de série</p>	

Orientamento della leva di sblocco

Release lever orientation

Ausrichtung des Bremslüfthebels

Orientation du levier de déblocage

Per entrambe le opzioni **R** e **RM**, la leva di sblocco del freno viene collocata, se non diversamente specificato, con orientamento di 90° in senso orario, rispetto alla posizione della morsettiera - riferimento **[AB]** nel disegno sottostante. Orientamenti alternativi, tipo **[AA]**, **[AC]** e **[AD]** possono essere richiesti citandone la relativa specifica:

Unless otherwise specified, the release lever is located 90° away from the terminal box – identified by letters **[AB]** in the diagram below – in a clockwise direction on both options **R** and **RM**. Alternative lever positions **[AA]**, **[AC]** and **[AD]** are also possible when the corresponding option is specified:

Bei beiden Optionen, **R** und **RM**, wird der Bremslüfthebel, falls nicht anderweitig festgelegt, um 90° im Uhrzeigersinn zur Position des Klemmenkastens montiert (Position **[AB]** in der nachfolgenden Zeichnung). Andere Positionen: **AA** (0° zum Klemmenkasten), **AC** (180° zum Klemmenkasten) oder **AD** (270° zum Klemmenkasten, im Uhrzeigersinn vom Lüfter aus gesehen) können unter Angabe der entsprechenden Spezifikation bestellt werden:

Pour les deux options **R** et **RM**, le levier de déblocage du frein est positionné, sauf spécification contraire, avec une orientation de 90° dans le sens des aiguilles d'une montre par rapport à la position de la boîte à bornes - référence **[AB]** sur le dessin ci-dessous. Des orientations différentes, type **[AA]**, **[AC]** et **[AD]** peuvent être demandées à condition de préciser la position correspondante :

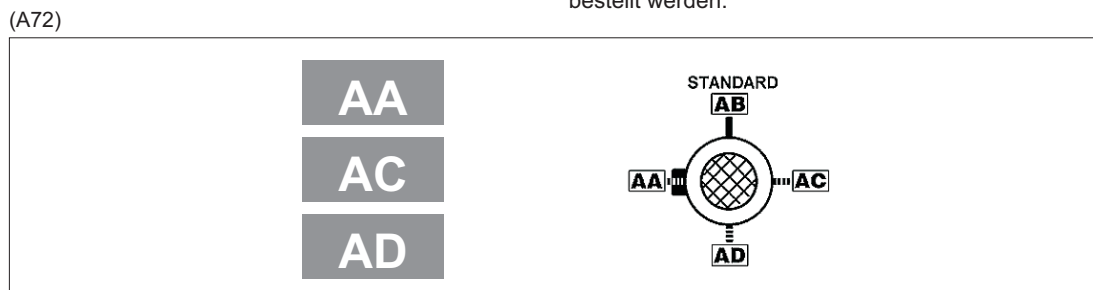

Caratteristiche volani (F1)

Fly-wheel data (F1)

Eigenschaften der Schwunräder (F1)

Caractéristiques volants (F1)

La tabella seguente riporta il peso e l'inerzia aggiuntiva dei volani che possono essere richiesti tramite l'opzione F1. Le dimensioni complessive rimangono invariate.

The table below shows values of weight and inertia of flywheel (option F1). Overall dimensions of motors remain unchanged.

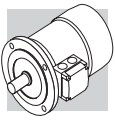

Die folgende Tabelle gibt das Gewicht und das Trägheitsmoment der Zusatzschwunräder an (Option F1). Die Gesamtmaße bleiben unverändert.

Le tableau suivante indique le poids et l'inertie des volants supplémentaires sans variations de l'encombrement moteur.



(A73)

Dati tecnici volano per motori tipo: / Main data for flywheel of motore type: / Eigenschaften der Schwungräder für Motoren typ: / Données volant pour moteurs type: BN_FD, M_FD

		Peso volano / Fly-wheel weight Gewicht Schwungrad / Poids volant [Kg]	Inerzia volano / Fly-wheel inertia Trägheitsmoment Schwungrad / Inertie volant [Kgm ²]
BN 63	M05	0.69	0.00063
BN 71	M1	1.13	0.00135
BN 80	M2	1.67	0.00270
BN 90 S - BN 90 L	–	2.51	0.00530
BN 100	M3	3.48	0.00840
BN 112	–	4.82	0.01483
BN 132 S - BN 132 M	M4	6.19	0.02580

M10 - OPZIONI

M10 - OPTIONS

M10 - OPTIONEN

M10 - OPTIONS

Protezioni termiche

Thermal protective devices

Thermische Schutzeinrichtungen

Protections thermiques

Oltre alla protezione garantita dall'interruttore magnetotermico, i motori possono essere provvisti di sonde termiche incorporate per proteggere l'avvolgimento da eccessivo riscaldamento dovuto a scarsa ventilazione o servizio intermittente.

Questa protezione dovrebbe sempre essere prevista per motori servoventilati (IC416).

In addition to the standard protection provided by the magneto-thermal device, motors can be supplied with built-in thermal probes to protect the winding against overheating caused, by insufficient ventilation or by an intermittent duty.

This additional protection should always be specified for servoventilated motors (IC416).

Abgesehen von den Motorschutzschaltern mit thermischem und elektromagnetischem Auslöser können die Motoren mit integrierten Temperaturfühlern zum Schutz der Wicklung vor Überhitzung z.B. wegen unzureichender Lüftung oder Aussetzbetriebs ausgestattet werden.

Diese Schutzeinrichtung muß bei fremdbelüfteten Motoren stets vorgesehen werden (IC416).

Outre la protection garantie par l'interrupteur magnétothermique, les moteurs peuvent être équipés de sondes thermiques incorporées pour protéger le bobinage contre une surchauffe excessive due par exemple à une ventilation insuffisante ou un service intermittent.

Cette protection devrait toujours être prévue pour les moteurs servoventilés (IC416).

E3

Sonde termiche a termistori

Thermistors

Temperaturfühler und Thermistoren

Sondes thermométriques

Sono dei semiconduttori che presentano una rapida variazione di resistenza in prossimità della temperatura nominale di intervento.

L'andamento della caratteristica $R = f(T)$ è normalizzato dalle Norme DIN 44081, IEC 34-11. Questi sensori presentano il vantaggio di avere ingombri ridotti, un tempo di risposta molto contenuto e, dato che il funzionamento avviene senza contatti, sono completamente esenti da usura.

In genere vengono impiegati termistori a coefficiente di temperatura positivo denominati anche "resistori a conduttore freddo" PTC.

A differenza delle sonde termiche bimetalliche, non possono intervenire direttamente sulle correnti delle bobine di eccitazione e devono pertanto essere collegati ad una speciale unità di controllo (apparecchio di sgancio) da interfacciare alle connessioni esterne.

Con questa protezione vengono inseriti tre PTC, (collegati in serie), nell'avvolgimento con terminali disponibili in morsettiera ausiliaria.

These are semi-conductors having rapid resistance variation when they are close to the rated switch off temperature.

Variations of the $R = f(T)$ characteristic are specified under DIN 44081, IEC 34-11 Standards.

These elements feature several advantages: compact dimensions, rapid response time and, being contact-free, absolutely no wear.

Positive temperature coefficient thermistors are normally used (also known as PTC "cold conductor resistors").

Contrary to bimetallic thermostats, they cannot directly intervene on currents of energizing coils, and must therefore be connected to a special control unit (triggering apparatus) to be interfaced with the external connections.

Thus protected, three PTCs connected in series are installed in the winding, the terminals of which are located on the auxiliary terminal-board.

Hierbei handelt es sich um Halbleiter, die eine schnelle Änderung des Widerstands in der Nähe der Nennansprechtemperatur zeigen.

Der Verlauf der Kennlinie $R = f(T)$ ist durch die DIN-Normen 44081 und IEC 34-11 festgelegt.

Diese Sensoren haben folgende Vorteile: sie weisen geringe Außenmaße und eine äußerst kurze Ansprechzeit auf und sind vollkommen verschleißfrei, da sie berührungslos arbeiten.

Im allgemeinen werden Thermistoren mit positivem Temperaturkoeffizienten verwendet, die auch als "Kaltleiter" (PTC-Widerstände) bezeichnet werden.

Im Unterschied zu Bimetal-Temperaturfühlern können sie nicht direkt auf die Erregungsströme der Spulen wirken, sondern müssen an eine spezielle Steuereinheit (Auslösegerät) angeschlossen werden, die mit den externen Anschlüssen kompatibel ist.

Mit dieser Schutzeinrichtung werden drei in Reihe geschaltete PTC-Widerstände in die Wicklung eingesetzt, deren Endanschlüsse an einer Zusatzklemmleiste verfügbar sind.

Ce sont des semiconducteurs qui présentent une variation rapide de résistance à proximité de la température nominale d'intervention.

L'évolution de la caractéristique $R = f(T)$ est défini par les Normes DIN 44081, IEC 34-11.

Ces capteurs présentent l'avantage d'avoir des encombrements réduits, un temps de réponse très bref et, du fait que le fonctionnement a lieu sans contact, il sont exempts d'usure.

En général, on utilise des thermistors à coefficient de température positif dénommés également "résistors à conducteur froid" PTC.

Contrairement aux sondes thermiques bimétalliques, ils ne peuvent intervenir directement sur les courants des bobines d'excitation et doivent par conséquent être reliés à une unité spéciale de contrôle (appareil de déconnexion) à interfacer aux connexions extérieures.

Avec cette protection, trois sondes, (reliées en série), sont insérées dans le bobinage avec extrémités disponibles dans le bornier auxiliaire.

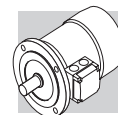

D3

Sonde termiche bimetalliche

I protettori di questo tipo contengono all'interno di un involucro un disco bimetallico che, raggiunta la temperatura nominale di intervento, commuta i contatti dalla posizione di riposo. Con la diminuzione della temperatura, il disco e i contatti riprendono automaticamente la posizione di riposo. Normalmente si impiegano tre sonde bimetalliche in serie con contatti normalmente chiusi e terminali disponibili in una morsettiere ausiliaria.

Bimetallic thermostates

These types of protective devices house a bimetal disk. When the rated switch off temperature is reached, the disk switches the contacts from their initial rest position. As temperature falls, the disk and the contacts automatically return to rest position. Three bimetallic thermostates connected in series are usually employed, with normally closed contacts. The terminals are located on an auxiliary terminal-board.

Bimetall-Temperaturfühler

Diese Schutzeinrichtungen bestehen aus einer Kapsel, in der sich eine Bimetallscheibe befindet, die bei Erreichen der Nennansprechtemperatur anspricht. Nach Absenkung der Temperatur geht der Schaltkontakt automatisch in Ruhestellung zurück. Normalerweise werden drei in Reihe geschaltete Bimetallfühler mit Öffnern verwendet, deren Endverschlüsse an einer Zusatzklemmleiste verfügbar sind.

Sondes thermiqes bimétalliques

Les protecteurs de ce type contiennent, dans une enveloppe interne, un disque bimétallique qui, lorsque la température nominale d'intervention est atteinte, commute les contacts de la position de repos. Avec la diminution de la température, le disque et les contacts reprennent automatiquement la position de repos. Normalement, on utilise trois sondes bimétalliques en série avec contacts normalement fermés et extrémités disponibles dans un bornier auxiliaire.

H1

Riscaldatori anticondensa

I motori funzionanti in ambienti molto umidi e/o in presenza di forti escursioni termiche, possono essere equipaggiati con una resistenza anti-condensa. L'alimentazione monofase è prevista da morsettiere ausiliaria posta nella scatola principale. Le potenze assorbite dalla resistenza elettrica sono elencate qui di seguito:

Anti-condensation heaters

Where an application involves high humidity or extreme temperature fluctuation, motors may be equipped with an anti-condensate heater. A single-phase power supply is available in the auxiliary terminal board inside the main terminal box. Values for the absorbed power are listed here below:



Wicklungsheizung

Die Motoren, die in besonders feuchten Umgebungen und/oder unter starken Temperaturschwankungen eingesetzt werden, können mit einem Heizelement als Kondenswasserschutz ausgestattet werden. Die einphasige Versorgung erfolgt über eine Zusatzklemmleiste, die sich im Klemmenkasten befindet. Werte fuer die Leistungsaufnahme sind in folgender Tabelle aufgeführt.

Rechauffeurs anticondensation

Les moteurs fonctionnant dans des milieux très humides et/ou en présence de fortes plages thermiques peuvent être équipés d'une résistance anticondensation. L'alimentation monophasée est prévue par l'intermédiaire d'une boîte à bornes auxiliaire située dans la boîte principale. Les puissances absorbées sont indiqués de suite :

(A74)

		H1
		1~ 230V ± 10% P [W]
BN 56...BN 80	M0...M2	10
BN 90...BN 160MR	M3 - M4	25
BN 160M...BN 180M	M5	50
BN 180L...BN 200L	—	65

Importante!
Durante il funzionamento del motore la resistenza anticondensa non deve mai essere in-

Warning!
Always remove power supply to the anti-condensate heater before operating the motor.

Warnung!
Während des Motorbetriebs darf die Wicklungsheizung nie gespeist werden.

Avertissement!
Durant le fontionnement du moteur, la résistance anticondensation ne doit jamais être alimentée.

PS

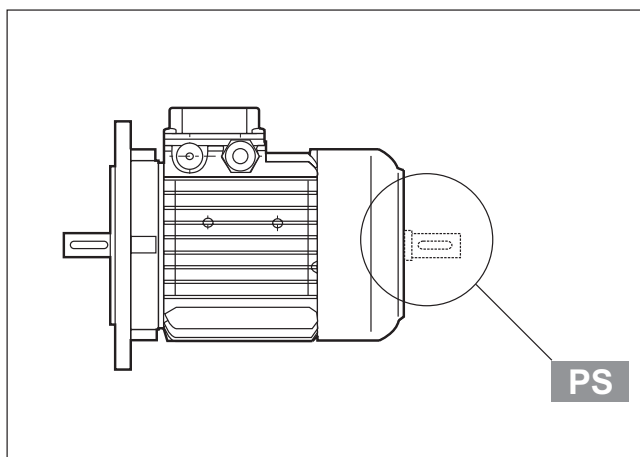

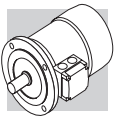

Seconda estremità d'albero

L'opzione esclude le varianti RC, TC, U1, U2, EN1, EN2, EN3 – non applicabile ai motori con freno tipo BA. Le dimensioni sono reperibili nelle tavole dimensionali dei motori.

Second shaft extension

This option is not compatible with variants RC, TC, U1, U2, EN1, EN2, EN3 – and is not feasible on motors equipped with BA brake. For shaft dimensions please see motor dimensions tables.

Zweites Wellenende

Diese Option schließt die Optionen RC, TC, U1, U2, EN1, EN2, EN3 aus – sie kann nicht außerdem nicht an Motoren, die mit einer Rückbremse vom Typ BA ausgestattet sind, angebaut werden. Die entsprechenden Maße können den Maßtabellen der Motoren entnommen werden.

Arbre à double extrémité

L'option exclut les variantes RC, TC, U1, U2, EN1, EN2, EN3 – non applicables aux moteurs avec frein type BA. Les dimensions figurent sur les planches de dimensions des moteurs.

AL

AR

Dispositivo antiritorno

Nelle applicazioni dove è necessario impedire la rotazione inversa del motore dovuta all'azione del carico, è possibile impiegare motori provvisti di un dispositivo antiritorno (disponibile solo sulla serie M). Questo dispositivo, pur consentendo la libera rotazione nel senso di marcia, interviene istantaneamente in caso di mancanza di alimentazione bloccando la rotazione dell'albero nel senso inverso.

Il dispositivo antiritorno è lubrificato a vita con grasso specifico per questa applicazione.

In fase di ordine dovrà essere indicato chiaramente il senso di marcia previsto.

In nessun caso il dispositivo antiritorno dovrà essere utilizzato per impedire la rotazione inversa nel caso di collegamento elettrico errato.

Nella tabella (A75) sono indicate le coppie nominale e massima di bloccaggio attribuite ai dispositivi antiritorno utilizzati, mentre la raffigurazione schematica del dispositivo è inserita nella tabella (A76).

Le dimensioni sono le stesse del motore autofrenante.

Backstop device

For applications where backdriving must be avoided, motors equipped with an anti run-back device can be used (available for the M series only). While allowing rotation in the direction required, this device operates instantaneously in case of a power failure, preventing the shaft from running back.

The anti run-back device is life lubricated with special grease for this specific application.

When ordering, customers should indicate the required rotation direction, AL or AR.

Never use the anti run-back device to prevent reverse rotation caused by faulty electrical connection.

Table (A75) shows rated and maximum locking torques for the anti run-back devices.

A diagram of the device can be seen in Table (A76).

Overall dimensions are same as the corresponding brake motor.

Rücklaufsperr

Für Anwendungen, bei denen ein durch die Last verursachtes Rücklaufen des Motors verhindert werden soll, können Motoren installiert werden, die über eine Rücklaufsperr verfügen (nur bei Serie M verfügbar).

Diese Vorrichtung, die eine völlig unbehinderte Drehung des Motors in Laufrichtung gestattet, greift sofort ein, wenn die Spannung fehlt, und verhindert die Drehung der Welle in die Gegenrichtung.

Die Rücklaufsperr verfügt über eine Dauer - Schmierung mit einem speziell für diese Anwendung geeigneten Fett.

Bei der Bestellung muß die vorgesehene Drehrichtung des Motors genau angegeben werden. Die Rücklaufsperr darf keinesfalls verwendet werden, um im Falle eines fehlerhaften elektrischen Anschlusses die Drehung in die Gegenrichtung zu verhindern.

In Tabelle (A75) sind die Nenndrehmomente und Höchst Drehmomente für die verwendeten Rücklaufsperr angegeben; Abbildung (A76) zeigt eine schematische Darstellung der Vorrichtung.

Die abmessungen sind ähnlich denen der Brems motoren.

Dispositif anti-retour

Pour les applications où il est nécessaire d'empêcher la rotation inverse du moteur à cause de l'action de la charge, il est possible d'utiliser des moteurs dotés d'un dispositif anti-retour (disponible seulement sur la série M).

Ce dispositif, bien que permettant la libre rotation dans le sens de marche, intervient instantanément en cas de manque d'alimentation en bloquant la rotation de l'arbre dans le sens inverse.

Le dispositif anti-retour est lubrifié à vie avec une graisse spécifique pour cette application.

En phase de commande, il faudra indiquer clairement le sens de marche prévu. En aucun cas, le dispositif anti-retour ne devra être utilisé pour empêcher la rotation inverse en cas de branchement électrique erroné.

Le tableau (A75) indique le couple nominal et le couple maximum de blocage attribués aux dispositifs anti-retour utilisés alors que la représentation schématique du dispositif se trouve dans le tableau (A76).

Les dimensions sont le même du moteur frein.

(A75)

	Coppia nominale di bloccaggio <i>Rated locking torque</i> Nenndrehmoment der Sperre <i>Couple nominal de blocage</i>	Coppia max. di bloccaggio <i>Max. locking torque</i> Max. Drehmoment der Sperre <i>Couple maxi. de blocage</i>	Velocità di distacco <i>Release speed</i> Ausrückgeschwindigkeit <i>Vitesse de décollement</i>
	[Nm]	[Nm]	[min ⁻¹]
M1	6	10	750
M2	16	27	650
M3	54	92	520
M4	110	205	430

(A76)

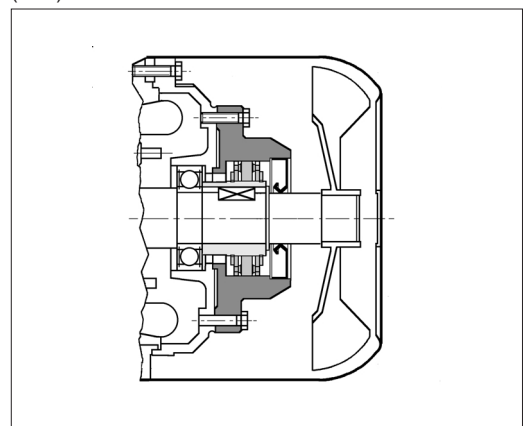

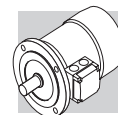

Ventilazione

I motori sono raffreddati mediante ventilazione esterna (IC 411 secondo CEI EN 60034-6) e sono provvisti di ventola radiale in plastica, funzionante in entrambi i versi di rotazione.

L'installazione dovrà assicurare una distanza minima della calotta copriventola dalla parete più vicina, in modo da non creare impedimento alla circolazione dell'aria, oltre che permettere l'esecuzione della manutenzione ordinaria del motore e, se presente, del freno.

Su richiesta, a partire dalle grandezze BN 71, oppure M1, i motori possono essere forniti con ventilazione forzata ad alimentazione indipendente. Il raffreddamento è realizzato per mezzo di un ventilatore assiale con alimentazione indipendente, montato sulla calotta copriventola (metodo di raffreddamento IC 416).

Questa esecuzione è utilizzata in caso di alimentazione del motore tramite inverter allo scopo di estendere il campo di funzionamento a coppia costante anche a bassa velocità, o quando per lo stesso sono richieste elevate frequenze di avviamento.

Da questa opzione sono esclusi i motori autofrenanti tipo BN_BA e tutti i motori con doppia sporgenza d'albero (opzione PS).

Ventilation

Motors are cooled through outer air blow (IC 411 according to CEI EN 60034-6) and are equipped with a plastic radial fan, which operates in both directions.

Ensure that fan cover is installed at a suitable distance from the closest wall so to allow air circulation and servicing of motor and brake, if fitted.

On request, motors can be supplied with independently power-supplied forced ventilation system starting from BN 71 or M1 size.

Motor is cooled by an axial fan with independent power supply and fitted on the fan cover (IC 416 cooling system).

This version is used in case of motor driven by inverter so that steady torque operation is possible even at low speed or when high starting frequencies are needed.

Brake motors of BN_BA type and all motors with rear shaft projection (PS option) are excluded.

Belüftung

Die Motoren werden mittels Fremdbelüftung gekühlt (IC 411 gemäß CEI EN 60034-6) und sind mit einem Radiallüfterrad aus Kunststoff ausgestattet, das in beide Richtungen dreht.

Die Installation muss zwischen Lüfterradkappe und der nächstliegenden Wand einen Mindestabstand berücksichtigen, so dass der Luftumlauf nicht behindert werden kann. Dieser Abstand ist jedoch ebenso für die regelmäßige Instandhaltung des Motors und, falls vorhanden, der Bremse erforderlich.

Ab der Baugröße BN 71 oder M1 können die Motoren auf Anfrage mit einer unabhängig gespeisten Zwangsbelüftung geliefert werden. Die Kühlung erfolgt hierdurch einen unabhängig gespeisten Axialventilator, der auf die Lüfterradkappe (Kühlmethode IC 416) montiert wird.

Diese Ausführung wird im Fall eines über einen Frequenzumrichter versorgten Motor verwendet, so dass der Betriebsbereich bei konstantem Drehmoment auch auf die niedrige Drehzahl ausgedehnt wird, oder im Fall von hohen Anlauffrequenzen.

Von dieser Option ausgeschlossen sind die Bremsmotoren BN_BA und Motoren mit beidseitig herausragender Welle (Option PS).

Ventilation

Les moteurs sont refroidis par ventilation externe (IC 411 selon CEI EN 60034-6) et sont équipés de ventilateur radial en plastique fonctionnant dans les deux sens de rotation.



L'installation doit garantir une distance minimum de la calotte cache-ventilateur par rapport au mur le plus proche de façon à ne pas créer d'empêchement à la circulation de l'air ainsi que pour permettre les interventions d'entretien ordinaire du moteur et, si présent, du frein.

Sur demande, à partir de la taille BN 71, ou M1, les moteurs peuvent être fournis avec ventilation forcée à alimentation indépendante. Le refroidissement est réalisé au moyen d'un ventilateur axial avec alimentation indépendante monté sur la calotte cache-ventilateur (méthode de refroidissement IC 416).

Cette exécution est utilisée en cas d'alimentation du moteur par variateur dans le but d'étendre aussi la plage de fonctionnement à couple constant aux faibles vitesses ou lorsque des fréquences de démarrage élevées sont nécessaire à celui-ci.

Les moteurs frein type BN_BA et les moteurs avec arbre sortant des deux côtés (option PS) SP sont exclus de cette option.

(A77)

Dati di alimentazione / Power supply / Daten der Stromversorgung / Données d'alimentation					
		V a.c. ± 10%	Hz	P [W]	I [A]
BN 71	M1	1~ 230	50 / 60	22	0.14
BN 80	M2			22	0.14
BN 90	—			40	0.25
BN 100 (*)	M3			50	0.25
BN 112	—	3~ 230 Δ / 400Y	50	50	0.26 / 0.15
BN 132S	M4S			110	0.38 / 0.22
BN 132M...BN 160MR	M4L				
BN 160...BN 180M	M5		50	180	1.25 / 0.72

Per la variante sono disponibili due esecuzioni alternative, denominate **U1** e **U2**, aventi lo stesso ingombro in senso longitudinale. Per entrambe le esecuzioni, la maggiore lunghezza della calotta copriventola (ΔL) è riportata nella tabella che segue. Dimensioni complessive ricavabili dalle tavole dimensionali dei motori.



This variant has two different models, called **U1** and **U2**, having the same longitudinal size. Longer side of fan cover (ΔL) is specified for both models in the table below. Overall dimension can be reckoned from motor size table.

Für die Varianten sind als Alternative zwei Ausführungen verfügbar: **U1** und **U2** mit dem gleichen Längsmaßen. Für beide Ausführungen wird die Verlängerung der Lüfterradkappe (ΔL) in der nachstehenden Tabelle wiedergegeben. Gesamtmaße können den Tabellen entnommen werden, in denen die Motormaße angegeben werden.

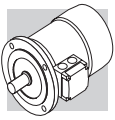
Pour la variante sont disponibles deux exécutions alternatives, dénommées **U1** et **U2**, ayant le même encombrement dans le sens longitudinal. Pour les deux exécutions, la majoration de la longueur de la calotte cache-ventilateur (ΔL) est indiquée dans le tableau suivant. Dimensions totales à calculer d'après les planches de dimensions des moteurs.



(A78)

Tabella maggiorazione lunghezze motore / Extra length for servoveilated motors Tabelle - Motorverlängerung / Tableau majoration longueurs moteur			
		ΔL_1	ΔL_2
BN 71	M1	93	32
BN 80	M2	127	55
BN 90	—	131	48
BN 100	M3	119	28
BN 112	—	130	31
BN 132S	M4S	161	51
BN 132M	M4L	161	51

ΔL_1 = variazione dimensionale rispetto alla quota LB del motore standard corrispondente

ΔL_1 = extra length to LB value of corresponding standard motor

ΔL_1 = Maßänderung gegenüber Maß LB des entsprechenden Standardmotors

ΔL_1 = variation de dimension par rapport à la cote LB du moteur standard correspondant

ΔL_2 = variazione dimensionale rispetto alla quota LB del motore autofrenante corrispondente

ΔL_2 = extra length to LB value of corresponding brake motor

ΔL_2 = Maßänderung gegenüber Maß LB des entsprechenden Bremsmotors

ΔL_2 = variation de dimension par rapport à la cote LB du moteur frein correspondant

U1



Terminali di alimentazione del ventilatore in scatola morsetti separata.

Nei motori autofrenanti grandezza BN 71...BN 160MR, con variante **U1**, la leva di sblocco non è collocabile nella posizione AA. L'opzione non è disponibile per i motori conformi alle norme CSA e UL (opzione CUS).

Fan wiring terminals are housed in a separate terminal box.

*In brake motors of size BN 71...BN 160MR, with **U1** model, the release lever cannot be positioned to AA.*

The option is not applicable to motors compliant with the CSA and UL norms (option CUS).

Versorgungsanschlüsse des Ventilators im Zusatzklemmenkasten.

Bei den Bremsmotoren in der Baugröße BN 71...BN 160MR, mit Variante **U1** kann der Bremslösehebel nicht in der Position AA. Die Option ist nicht anwendbar für die Motoren entsprechend den Normen CSA und UL (Option CUS).

Bornes d'alimentation du ventilateur dans un bornier séparé.

*Pour les moteurs frein taille BN 71...BN 160MR, avec variante **U1**, le levier de déblocage ne peut être installé en position AA. L'option n'est pas disponible pour les moteurs conformes aux normes CSA et UL (option CUS).*

U2



I terminali del ventilatore sono collocati nella scatola morsetti-riera principale del motore.

L'opzione U2 non è applicabile ai motori da BN 160 a BN 200L, con eccezione dei motori BN 160MR, per i quali l'opzione è disponibile e ai motori con opzione CUS (conformi alle norme CSA e UL).

Fan terminals are wired in the motor terminal box.

The U2 option does not apply to motors BN 160 through BN 200L, with the only exception of motor BN 160MR for which the option is available instead and to motors with option CUS (compliant to norms CSA and UL).



Versorgungsanschlüsse des Ventilators befinden sich im Hauptklemmenkasten des Motors.

Die Option U2 ist nicht anwendbar bei den Motoren BN160M...BN200L, außer den Motoren BN160MR wofür die Option verfügbar ist, und bei den Motoren mit der CUS-Option (entsprechend den Normen CSA und UL).

Bornes d'alimentation du ventilateur dans le bornier principal du moteur.

L'option n'est pas applicable aux moteurs BN 160...BN 200L, sauf pour les moteurs BN 160MR, pour lesquels l'option est disponible et aux moteurs avec l'option CUS (conforme aux normes CSA et UL).

(A79)

(*)			V a.c. \pm 10%	Hz	P [W]	I [A]
	BN 100_U2	M3	3~ 230 Δ / 400Y	50 / 60	40	0.24 / 0.14

RC

Tettuccio parapioggia

Il dispositivo parapioggia, che è raccomandato quando il motore è montato verticalmente con l'albero verso il basso, serve a proteggere il motore stesso dall'ingresso di corpi solidi e dallo stillicidio.

Drip cover

The drip cover protects the motor from dripping and avoids the ingress of solid bodies. It is recommended when motor is installed in a vertical position with the shaft downwards.

Schutzdach

Das Schutzdach, dessen Montage dann empfohlen wird, wenn der Motor senkrecht mit einer nach unten gerichteten Welle ausgerichtet wird, dient dem Schutz des Motors vor einem Eindringen von festen Fremdkörpern und Tropfwasser.

Capot de protection anti-pluie

Le capot de protection anti-pluie est recommandé lorsque le moteur est monté verticalement avec l'arbre vers le bas, il sert à protéger le moteur contre l'introduction de corps solides et le suintement.

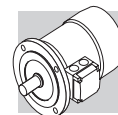



Le dimensioni aggiuntive sono indicate nella tabella (A80). Il tettuccio esclude le varianti PS, EN1, EN2, EN3 e non è applicabile ai motori con freno tipo BA

Relevant dimensions are indicated in the table (A80). The drip cover is not compatible with variants PS, EN1, EN2, EN3 and will not fit motors equipped with a BA brake.

Die Maßerweiterungen werden in der Tabelle (A80) angegeben. Das Schutzdach schließt die Möglichkeit der Varianten PS, EN1, EN2, EN3 und kann bei Motoren mit dem Bremstyp BA nicht montiert werden.

Les dimensions à ajouter sont indiquées dans le tableau (A80). Le capot antipluie exclue les variantes PS, EN1, EN2, EN3 et n'est pas applicable aux moteurs avec frein type BA.

(A80)

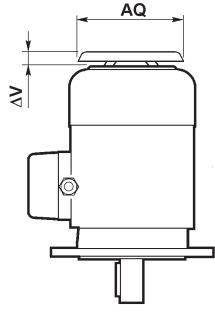
		AQ	ΔV	
BN 63	M05	118	24	
BN 71	M1	134	27	
BN 80	M2	152	25	
BN 90	—	168	30	
BN 100	M3	190	28	
BN 112	—	211	32	
BN 132...BN 160MR	M4	254	32	
BN 160M...BN 180M	M5	302	36	
BN 180L...BN 200L	—	340	36	

TC

Tettuccio tessile

La variante del tettuccio tipo TC è da specificare quando il motore è installato in ambienti dell'industria tessile, dove sono presenti filamenti che potrebbero ostruire la griglia del copriventola, impedendo il regolare flusso dell'aria di raffreddamento. L'opzione esclude le varianti EN1, EN2, EN3 e non è applicabile ai motori con freno tipo BA. L'ingombro complessivo è lo stesso del tettuccio tipo RC.

Textile canopy

Option TC is a cover variant for textile industry environments, where lint may obstruct the fan grid and prevent a regular flow of cooling air. This option is not compatible with variants EN1, EN2, EN3 and will not fit motors equipped with a BA brake. Overall dimensions are the same as drip cover type RC.

Schutzdach

Die Variante des Schutzdachs vom Typ TC muss dann spezifiziert werden, wenn der Motor in Bereichen der Textilindustrie installiert wird, in denen Stofffusseln das Lüfterradgitter verstopfen und so einen regulären Kühlluftfluss verhindern könnten. Diese Option schließt die Möglichkeit der Varianten EN1, EN2, EN3 aus und kann bei Motoren mit einer Bremse vom Typ BA nicht appliziert werden. Die Gesamtmaße entsprechen denen des Schutzdachs vom Typ RC.

Capot textile

La variante del capot type TC est à spécifier lorsque le moteur est installé dans des sites de l'industrie textile, où sont présents des filaments qui pourraient obstruer la grille du cache-ventilateur et empêcher le flux régulier de l'air de refroidissement. L'option exclue les variantes EN1, EN2, EN3 et n'est pas applicable aux moteurs avec frein type BA. L'encombrement total est identique à celui du capot type RC.

Dispositivi di retroazione

I motori possono essere dotati di tre diversi tipi di encoder, qui di seguito descritti. Il montaggio dell'encoder esclude le esecuzioni con doppia estremità d'albero (PS) e tettuccio di protezione (RC, TC). Il dispositivo non è applicabile ai motori dotati del freno in c.a., tipo BA.

Feedback units

Motors may be combined with three different types of encoders to achieve feedback circuits. Configurations with double-extended shaft (PS) and rain canopy (RC, TC) are not compatible with encoder installation. Also not compatible are motors equipped with a.c. brakes, type BA.

Geber-anschluß

Die Motoren können mit drei unterschiedlichen Encodertypen ausgestattet werden. Nachstehend finden Sie die entsprechenden Beschreibungen. Die Montage des Encoders schließt die Version mit zweitem Wellenende (PS) und Schutzdach (RC, TC) aus. Die Vorrichtung kann an Motoren mit Bremse vom Typ BA nicht angebaut werden.

Dispositifs de retroaction

Pour moteurs peuvent être dotés de trois types de codeurs différents, décrits ci-après. Le montage du codeur exclu les exécutions avec arbre à double extrémité (PS) et le capot de protection (RC, TC). Le dispositif n'est pas applicable aux moteurs avec frein en c.a., type BA.

EN1

Encoder incrementale, $V_{IN}=5\text{ V}$, uscita line-driver RS 422.

Incremental encoder, $V_{IN}=5\text{ V}$, line-driver output RS 422.

Inkremental-Encoder, $V_{IN}=5\text{ V}$, Ausgang „line-driver“ RS 422.

Codeur incrémental, $V_{IN}=5\text{ V}$, sortie line-driver RS 422.

EN2

Encoder incrementale, $V_{IN}=10-30\text{ V}$, uscita line driver RS 422.

Incremental encoder, $V_{IN}=10-30\text{ V}$, line-driver output RS 422.

Inkremental-Encoder, $V_{IN}=10-30\text{ V}$, Ausgang „line driver“ RS 422.

Codeur incrémental, $V_{IN}=10-30\text{ V}$, sortie line-driver RS 422.

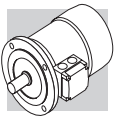

EN3

Encoder incrementale, $V_{IN}=12-30$ V, uscita push-pull 12-30 V

Incremental encoder, $V_{IN}=12-30$ V, push-pull output 12-30 V

Inkremental-Encoder, $V_{IN}=12-30$ V, Ausgang „push-pull“ 12-30 V

Codeur incrémental, $V_{IN}=12-30$ V, sortie push-pull 12-30 V

(A81)

	EN1	EN2	EN3
interfaccia / Interface Schnittstelle / interface	RS 422	RS 422	push-pull
tensione alimentazione / Power supply voltage Versorgungsspannung / tension d'alimentation	[V] 4...6	10...30	12...30
tensione di uscita / Output voltage Ausgangsspannung / tension de sortie	[V] 5	5	12...30
corrente di esercizio senza carico / No-load operating current Betriebsstrom ohne Belastung / courant d'utilisation sans charge	[mA] 120	100	100
n° di impulsi per giro / No. of pulses per revolution Impulse pro Drehung / nbre d'impulsions par tour	1024		
n° segnali / No. of signals Signale / nbre de signaux	6 (A, B, C + segnali invertiti / inverted signals invertierte Signale / signaux inversés)		
max. frequenza di uscita / Max. output frequency Max. Ausgangsfrequenz / fréquence max. de sortie	[kHz] 300	300	200
max. velocità / Max. speed Max. Drehzahl / vitesse max.	[min ⁻¹] 6000 (9000 min ⁻¹) x 10s		
campo di temperatura / Temperature range Temperaturbereich / plage de température	[°C] -20...+70		
grado di protezione / Protection class Schutzgrad / degré de protection	IP 65		

EN1, EN2, EN3	
BN 63...BN 200L	M05...M5
BN 63_FD...BN 200L_FD	M05_FD...M5_FD
BN 63_FA...BN 200L_FA	M05_FA...M5_FA

EN_ + U1		
		L3
BN 160M...BN 180M	M5	72
BN 180L...BN 200L	-	82
BN 160M_FD...BN 180M_FD	M5_FD	35
BN 180L_FD...BN 200L_FD	-	41

Se l'opzione EN_ è richiesta per motori di grandezza BN71...BN160MR e M1...M4, contemporaneamente all'opzione U1/U2, le variazioni dimensionali coincidono con quelle dell'opzione U1/U2.

If the encoder device (options EN1, EN2, EN3) is specified on motors BN71...BN160MR and M1...M4, along with the independent fan cooling (options U1, U2), the extra length of motor is coincident with that of the correspondent U1 and U2 execution.

Wenn der Encoder (Optionen EN1, EN2, EN3) für Motoren der Baugrößen BN71...BN160MR und M1...M4 zusammen mit Fremd Lüftung (Optionen U1, U2) ausgelegt ist, stimmen die Maßänderungen des Motors mit jenen der entsprechenden Ausführungen U1 und U2 überein.

Si un codeur (option EN1, EN2, EN3) est nécessaire sur les moteurs de tailles BN71...BN160MR et M1...M4, en association avec la ventilation forcée (options U1, U2), la variation de dimensions du moteur coïncide avec celle des exécutions U1 et U2 correspondantes.

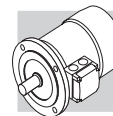





2 P

3000 min⁻¹ - S1

50 Hz

Pn kW		n min ⁻¹	Mn Nm	EFF2	η (100%) %	η (75%) %	cos φ	In A	Is In	Ms Mn	Ma Mn	Jm x 10 ⁻⁴ kgm ²	IM B5 Kg	freno c.c. / d.c. brake G.S.-bremse / frein c.c.				freno c.a. / a.c. brake W.S.-bremse / frein c.a.													
														Mod.	Mb Nm	Z ₀ 1/h	SB	IM B5 Kg	Jm x 10 ⁻⁴ kgm ²	Z ₀ 1/h	Mb Nm	Mod.	Mb max Nm	Z ₀ 1/h	IM B5 Kg	Jm x 10 ⁻⁴ kgm ²					
																											NB	FA	BA		
0.18	BN 63A 2	2730	0.63		59.9	56.9	0.77	0.56	3.0	2.1	2	2.0	3.5	FD 02	1.75	3900	4800	2.6	5.2	FA 02	1.75	4800	4800	2.6	5.0	BA 60	5	3500	4.0	5.8	
0.25	BN 63B 2	2740	0.87		66.0	64.8	0.76	0.72	3.3	2.3	2.3	2.3	3.9	FD 02	1.75	3900	4800	3.0	5.6	FA 02	1.75	4800	4800	3.0	5.4	BA 60	5	3600	4.3	6.2	
0.37	BN 63C 2	2800	1.26		69.1	66.8	0.78	0.99	3.9	2.6	2.6	3.3	5.1	FD 02	3.5	3600	4500	3.9	6.8	FA 02	3.5	4500	4500	3.9	6.6	BA 60	5	3500	5.3	7.4	
0.37	BN 71A 2	2820	1.25		73.8	73.0	0.76	0.95	4.8	2.8	2.6	3.5	5.4	FD 03	3.5	3000	4100	4.6	8.1	FA 03	3.5	4200	4200	4.6	7.8	BA 70	8	3500	5.5	9.3	
0.55	BN 71B 2	2820	1.86		76.0	75.8	0.76	1.37	5.0	2.9	2.8	4.1	6.2	FD 03	5	2900	4200	5.3	8.9	FA 03	5	4200	4200	5.3	8.6	BA 70	8	3600	6.1	10.1	
0.75	BN 71C 2	2810	2.6		76.6	76.2	0.76	1.86	5.1	3.1	2.8	5.0	7.3	FD 03	5	1900	3300	6.1	10	FA 03	5	3600	3600	6.1	9.7	BA 70	8	3200	7.0	11.2	
0.75	BN 80A 2	2810	2.6		76.2	75.5	0.81	1.75	4.8	2.6	2.2	7.8	8.6	FD 04	5	1700	3200	9.4	12.5	FA 04	5	3200	3200	9.4	12.4	BA 80	18	2800	10.8	13.9	
1.1	BN 80B 2	2800	3.8	EFF2	76.4	76.2	0.81	2.57	4.8	2.8	2.4	9.0	9.5	FD 04	10	1500	3000	10.6	13.4	FA 04	10	3000	3000	10.6	13.3	BA 80	18	2700	12.0	14.8	
1.5	BN 80C 2	2800	5.1	EFF2	79.1	79.5	0.81	3.4	4.9	2.7	2.4	11.4	11.3	FD 04	15	1300	2600	13.0	15.2	FA 04	15	2600	2600	13.0	15.1	BA 80	18	2400	14.4	16.6	
1.5	BN 90SA 2	2870	5.0	EFF2	82.0	81.5	0.80	3.3	5.9	2.7	2.6	12.5	12.3	FD 14	15	900	2200	14.1	16.5	FA 14	15	2200	2200	14.1	16.4	BA 90	35	1600	19.5	19.6	
1.85	BN 90SB 2	2880	6.1	EFF2	82.5	82.0	0.80	4.0	6.2	2.9	2.6	16.7	14	FD 14	15	900	2200	18.3	18.2	FA 14	15	2200	2200	18.3	18.1	BA 90	35	1700	23.7	21.3	
2.2	BN 90L 2	2880	7.3	EFF2	82.7	82.1	0.80	4.8	6.3	2.9	2.7	16.7	14	FD 05	26	900	2200	21	20	FA 05	26	2200	2200	21	20.7	BA 90	35	1700	24	21.3	
3	BN 100L 2	2860	10.0	EFF2	82.8	82.6	0.79	6.6	5.7	2.6	2.2	31	20	FD 15	26	700	1600	35	26	FA 15	26	1600	1600	35	27	BA 100	50	1300	43	30	
4	BN 100LB 2	2870	13.3	EFF2	84.3	84.4	0.80	8.6	5.9	2.7	2.5	39	23	FD 15	40	450	900	43	29	FA 15	40	1000	1000	43	30	BA 100	50	850	51	33	
4	BN 112M 2	2900	13.2	EFF2	85.5	84.5	0.82	8.2	6.9	3	2.9	57	28	FD 06S	40	—	950	66	39	FA 06S	40	950	950	66	40	BA 110	75	850	73	41	
5.5	BN 132SA 2	2890	18.2	EFF2	86.1	85.7	0.84	11.0	6	2.6	2.2	101	35	FD 06	50	—	600	112	48	FA 06	50	600	600	112	49	BA 140	150	500	151	67	
7.5	BN 132SB 2	2900	25	EFF2	87.2	87.1	0.85	14.6	6.4	2.6	2.2	145	42	FD 06	50	—	550	154	55	FA 06	50	550	550	154	56	BA 140	150	450	195	74	
9.2	BN 132M 2	2930	30	EFF2	89.0	88.5	0.86	17.3	6.9	2.8	2.3	178	53	FD 06	75	—	430	189	66	FA 06	75	430	430	189	67	BA 140	150	400	228	85	
11	BN 160MR 2	2920	36	EFF2	89.1	88.9	0.88	20.2	7.0	2.9	2.5	210	65																		
15	BN 160MB 2	2930	49	EFF2	89.6	89.4	0.86	28.1	7.1	2.6	2.3	340	84																		
18.5	BN 160L 2	2930	60	EFF2	90.4	90.1	0.86	34	7.6	2.7	2.3	420	97																		
22	BN 180M 2	2930	72	EFF2	91.3	91.3	0.88	40	7.8	2.6	2.4	490	109																		
30	BN 200LA 2	2930	98	EFF2	91.9	91.4	0.89	53	7.9	2.7	2.9	770	140																		

Pn kW		n min ⁻¹	Mn Nm	η %	cos φ	In [400V] A	Is In	Ms Mn	Ma Mn	Jm x 10 ⁻⁴ kgm ²	IM B5 	freno c.c. / d.c. brake G.S.-bremse / frein c.c.						freno c.a. / a.c. brake W.S.-bremse / frein c.a.											
												FD			FA			BA			FD			FA			BA		
												Mod.	Mb Nm	Zo 1/h NB SB	Jm x 10 ⁻⁴ kgm ²	IM B5 	Mod.	Mb Nm	Zo 1/h	Jm x 10 ⁻⁴ kgm ²	IM B5 	Mod.	Mb Nm	Zo 1/h	Jm x 10 ⁻⁴ kgm ²	IM B5 			
0.09	BN 63A	6	0.98	41	0.53	0.60	2.1	2.1	1.8	3.4	4.6	FD 02	3.5	9000	14000	4.0	6.3	FA 02	3.5	14000	4.0	6.1	BA 60	5	12000	5.4	6.9		
0.12	BN 63B	6	1.32	45	0.60	0.64	2.1	1.9	1.7	3.7	4.9	FD 02	3.5	9000	14000	4.3	6.6	FA 02	3.5	14000	4.3	6.4	BA 60	5	12000	5.7	7.2		
0.18	BN 71A	6	1.91	56	0.69	0.67	2.6	1.9	1.7	8.4	5.5	FD 03	5.0	8100	13500	9.5	8.2	FA 03	5.0	13500	9.5	7.9	BA 70	8	12300	10.4	9.4		
0.25	BN 71B	6	2.7	62	0.71	0.82	2.6	1.9	1.7	10.9	6.7	FD 03	5.0	7800	13000	12	9.4	FA 03	5.0	13000	12	9.1	BA 70	8	12000	12.9	10.6		
0.37	BN 71C	6	3.9	66	0.69	1.17	3	2.4	2.0	12.9	7.7	FD 53	7.5	5100	9500	14	10.4	FA 03	7.5	9500	14	10.1	BA 70	8	8900	14.9	11.6		
0.37	BN 80A	6	3.9	68	0.68	1.15	3.2	2.2	2.0	21	9.9	FD 04	10	5200	8500	23	13.8	FA 04	10	8500	23	13.7	BA 80	18	8000	24	15.2		
0.55	BN 80B	6	5.7	70	0.69	1.64	3.9	2.6	2.2	25	11.3	FD 04	15	4800	7200	27	15.2	FA 04	15	7200	27	15.1	BA 80	18	6800	28	16.6		
0.75	BN 80C	6	7.8	70	0.65	2.38	3.8	2.5	2.2	28	12.2	FD 04	15	3400	6400	30	16.1	FA 04	15	6400	30	16.0	BA 80	18	6100	31	17.5		
0.75	BN 90S	6	7.8	69	0.68	2.31	3.8	2.4	2.2	26	12.6	FD 14	15	3400	6500	28	16.8	FA 14	15	6500	28	16.7	BA 90	35	5500	33	19.9		
1.1	BN 90L	6	11.4	72	0.69	3.2	3.9	2.3	2.0	33	15	FD 05	26	2700	5000	37	21	FA 05	26	5000	37	22	BA 90	35	4600	40	22		
1.5	BN 100LA	6	15.2	73	0.72	4.1	4	2.1	2.0	82	22	FD 15	40	1900	4100	86	28	FA 15	40	4100	86	29	BA 100	50	3800	94	32		
1.85	BN 100LB	6	19.0	75	0.73	4.9	4.5	2.1	2.0	95	24	FD 15	40	1700	3600	99	30	FA 15	40	3600	99	31	BA 100	50	3400	107	34		
2.2	BN 112M	6	22	78	0.73	5.6	4.8	2.2	2.0	168	32	FD 06S	60	—	2100	177	42	FA 06S	60	2100	177	44	BA 110	75	2000	184	45		
3	BN 132S	6	30	76	0.76	7.5	4.8	1.9	1.8	216	36	FD 56	75	—	1400	226	49	FA 06	75	1400	226	50	BA 140	150	1200	266	68		
4	BN 132MA	6	40	78	0.77	9.6	5.5	2.0	1.8	295	45	FD 06	100	—	1200	305	58	FA 07	100	1200	318	63	BA 140	150	1050	345	77		
5.5	BN 132MB	6	56	80	0.78	12.7	5.9	2.1	1.9	383	56	FD 07	150	—	1050	406	72	FA 07	150	1050	406	74	BA 140	150	1000	433	88		
7.5	BN 160M	6	75	84	0.81	15.9	5.9	2.2	2.0	740	83	FD 08	170	—	900	815	112	FA 08	170	900	815	113							
11	BN 160L	6	109	87	0.81	22.5	6.5	2.5	2.3	970	103	FD 08	200	—	800	1045	133	FA 08	200	800	1045	133							
15	BN 180L	6	148	88	0.82	30	6.2	2.0	2.4	1550	130	FD 09	300	—	600	1750	170												
18.5	BN 200LA	6	184	88	0.81	37	5.9	2.0	2.3	1700	145	FD 09	400	—	450	1900	185												

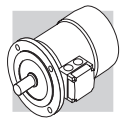

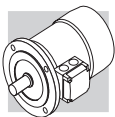











2/4 P

3000/1500 min⁻¹ - S1



50 Hz



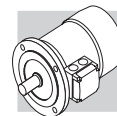

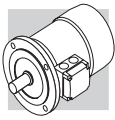
Pn kW		n min ⁻¹	Mh Nm	η %	cos φ	In [400V] A	Is In	Ms Mn	Ma Mn	Jm x 10 ⁻⁴ kgm ²	IMB5 	freno c.c. / d.c. brake G.S.-bremse / frein c.c.						freno c.a. / a.c. brake W.S.-bremse / frein c.a.											
												FD			FA			BA			FD			FA			BA		
												Mod.	Mb Nm	Zo 1/h	Jm x 10 ⁻⁴ kgm ²	IMB5 	Mod.	Mb Nm	Zo 1/h	Jm x 10 ⁻⁴ kgm ²	IMB5 	Mod.	Mb Nm	Zo 1/h	Jm x 10 ⁻⁴ kgm ²	IMB5 			
0.20	BN 63B	2	0.71	55	0.82	0.64	3.5	2.1	1.9	2.9	4.4	FD 02	3.5	2200	2600	3.5	6.1	FA 02	3.5	2600	5100	3.5	5.9	BA 60	5	2000	49	6.7	
0.15		4	1.06	49	0.67	0.66	2.6	1.8	1.7	4.7	4.4		4000	5100												4000			
0.28	BN 71A	2	0.99	56	0.82	0.88	2.9	1.9	1.7	4.7	4.4	FD 03	3.5	2100	2400	5.8	7.1	FA 03	3.5	2400	4800	5.8	6.8	BA 70	8	2100	56	8.3	
0.20		4	1.39	59	0.72	0.68	3.1	1.8	1.7	5.8	5.1		3800	4800												4200			
0.37	BN 71B	2	1.29	56	0.82	1.16	3.5	1.8	1.8	5.8	5.1	FD 03	5	1400	2100	6.9	7.8	FA 03	5	2100	4200	6.9	7.5	BA 70	8	1800	7.8	9.0	
0.25		4	1.72	60	0.73	0.82	3.3	2.0	1.9	6.9	5.9		2900	4200												3600			
0.45	BN 71C	2	1.55	63	0.85	1.21	3.8	1.8	1.8	6.9	5.9	FD 03	5	1400	2100	8.0	8.6	FA 03	5	2100	4200	8.0	8.3	BA 70	8	1800	8.9	9.8	
0.30		4	2.0	63	0.73	0.94	3.6	2.0	1.9	15	8.2		2900	4200												3600			
0.55	BN 80A	2	1.9	63	0.85	1.48	3.9	1.7	1.7	15	8.2	FD 04	5	1600	2300	16.6	12.1	FA 04	5	2300	4000	16.6	12.0	BA 80	18	2100	18	13.5	
0.37		4	2.5	67	0.79	1.01	4.1	1.8	1.9	20	9.9		3000	4000												3700			
0.75	BN 80B	2	2.6	65	0.85	1.96	3.8	1.9	1.8	20	9.9	FD 04	10	1400	1600	22	13.8	FA 04	10	1600	3600	22	13.7	BA 80	18	1500	22	15.2	
0.55		4	3.8	68	0.81	1.44	3.9	1.7	1.7	20	9.9		2700	3600												3300			
1.1	BN 90S	2	3.8	71	0.82	2.73	4.7	2.3	2.0	21	12.2	FD 14	10	1500	1600	23	16.4	FA 14	10	1600	2800	23	16.3	BA 90	35	1300	28	19.5	
0.75		4	5.2	66	0.79	2.08	4.6	2.4	2.2	28	14.0		2300	2800												2300			
1.5	BN 90L	2	5.2	70	0.85	3.64	4.5	2.4	2.1	28	14.0	FD 05	26	1050	1200	32	20	FA 05	26	1200	2000	32	21	BA 90	35	1100	35	21	
1.1		4	7.6	73	0.81	2.69	4.7	2.5	2.2	28	14.0		1600	2000												1800			
2.2	BN 100LA	2	7.5	72	0.85	5.2	4.5	2.0	1.9	40	18.3	FD 15	26	600	900	44	25	FA 15	26	900	1900	44	25	BA 100	50	750	51	29	
1.5		4	10.2	73	0.79	3.8	4.7	2.0	2.0	40	18.3		1300	2300												1900			
3.5	BN 100LB	2	11.7	80	0.84	7.5	5.4	2.2	2.1	61	25	FD 15	40	500	900	65	31	FA 15	40	900	2100	65	32	BA 100	50	750	72	35	
2.5		4	16.8	82	0.80	5.5	5.2	2.2	2.2	98	30		1000	2100												1800			
4	BN 112M	2	13.3	79	0.83	8.8	6.1	2.4	2.0	98	30	FD 06S	60	—	—	107	40	FA 06S	60	700	107	40	42	BA 110	75	600	114	43	
3.3		4	22.2	80	0.80	7.4	5.1	2.1	2.0	213	44		—	—	—	—	—									1100			
5.5	BN 132S	2	18.2	80	0.87	11.4	5.9	2.4	2.0	213	44	FD 06	75	—	—	223	57	FA 06	75	350	223	57	58	BA 140	150	300	263	76	
4.4		4	29	82	0.84	9.2	5.3	2.2	2.0	270	53		—	—	—	—	—									750			
7.5	BN 132MA	2	25	82	0.87	15.2	6.5	2.4	2.0	270	53	FD 06	100	—	—	280	66	FA 07	100	350	293	71	71	BA 140	150	300	320	85	
6		4	40	84	0.85	12.1	5.8	2.3	2.1	319	59		—	—	—	—	—									800			
9.2	BN 132MB	2	30	83	0.86	18.6	6.0	2.6	2.2	319	59	FD 07	150	—	—	342	75	FA 07	150	300	342	77	77	BA 140	150	300	369	91	
7.3		4	48	85	0.85	14.6	5.5	2.3	2.1	319	59		—	—	—	—	—									750			

Pn kW		n min ⁻¹	Mh Nm	η %	cos φ	In [400V] A	Is In	Ms Mn	Ma Mn	Jm x 10 ⁻⁴ kgm ²	IMB5 	freno c.c. / d.c. brake G.S.-bremse / frein c.c.						freno c.a. / a.c. brake W.S.-bremse / frein c.a.						
												FD			FA			BA			FD			FA
												Mod.	Mb Nm	Zo 1/h	SB	IMB5 	Mod.	Mb Nm	Zo 1/h	IMB5 	Mod.	Mb Nm	Zo 1/h	IMB5 
0.25	BN 71A	2	0.84	60	0.82	0.73	4.3	1.9	1.8	6.9	5.9	FD 03	1.75	1500	1700	8.6	FA 03	2.5	1700	8.0	BA 70	8	1500	8.9
0.08		6	0.84	43	0.70	0.38	2.1	1.4	1.5				10000	13000					13000				11000	
0.37	BN 71B	2	1.23	62	0.80	1.08	4.4	1.9	1.8	9.1	7.3	FD 03	3.5	1000	1300	10.0	FA 03	3.5	1300	10.2	BA 70	8	1200	11.1
0.12		6	1.27	44	0.73	0.54	2.4	1.4	1.5				9000	11000					11000				10000	
0.55	BN 80A	2	1.88	63	0.86	1.47	4.5	1.9	1.7	20	9.9	FD 04	5	1500	1800	13.8	FA 04	5	1800	22	BA 80	18	1700	23
0.18		6	1.85	52	0.65	0.77	3.3	2	1.9				4100	6300					6300				6000	
0.75	BN 80B	2	2.6	66	0.87	1.89	4.3	1.8	1.6	25	11.3	FD 04	5	1700	1900	15.2	FA 04	5	1900	27	BA 80	18	1800	28
0.25		6	2.6	54	0.67	1.00	3.2	1.7	1.8				3800	6000					6000				5600	
1.1	BN 90L	2	3.7	67	0.84	2.82	4.7	2.1	1.9	28	14.0	FD 05	13	1400	1600	20	FA 05	13	1600	32	BA 90	35	1500	35
0.37		6	3.8	59	0.71	1.27	3.3	1.6	1.6				3400	5200					5200				4700	
1.5	BN 100LA	2	5.0	73	0.84	3.53	5.1	1.9	2.0	40	18.3	FD 15	13	1000	1200	24	FA 15	13	1200	44	BA 100	50	1050	51
0.55		6	5.6	64	0.67	1.85	3.5	1.7	1.8				2900	4000					4000				3500	
2.2	BN 100LB	2	7.2	77	0.85	4.9	5.9	2.0	2.0	61	25	FD 15	26	700	900	31	FA 15	26	900	65	BA 100	50	800	72
0.75		6	7.5	67	0.64	2.5	3.3	1.9	1.8				2100	3000					3000				2700	
3	BN 112M	2	9.9	78	0.87	6.4	6.3	2.0	2.1	98	30	FD 06S	40	—	1000	40	FA 06S	40	1000	107	BA 110	75	930	114
1.1		6	11.1	72	0.64	3.4	3.9	1.8	1.8				—	2600					2600				2400	
4.5	BN 132S	2	14.8	78	0.84	9.9	5.8	1.9	1.8	213	44	FD 56	37	—	500	57	FA 06	37	500	223	BA 140	150	400	263
1.5		6	14.9	74	0.67	4.4	4.2	1.9	2.0				—	2100					2100				1700	
5.5	BN 132M	2	18.0	78	0.87	11.7	6.2	2.1	1.9	270	53	FD 56	50	—	400	66	FA 06	50	400	280	BA 140	150	350	320
2.2		6	22	77	0.71	5.8	4.3	2.1	2.0				—	1900					1900				1600	









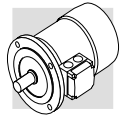

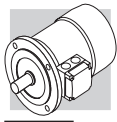
Pn kW		n min ⁻¹	Mh Nm	η %	cos φ	In [400V] A	Is In	Ms Mn	Ma Mn	Jm x 10 ⁻⁴ kgm ²	IM B5 	freno c.c. / d.c. brake G.S.-bremse / frein c.c.						freno c.a. / a.c. brake W.S.-bremse / frein c.a.											
												FD			FA			BA			FD			FA			BA		
												Mod.	Mb Nm	Zo 1/h	Mod.	Mb Nm	Zo 1/h	Mod.	Mb Nm	Zo 1/h	Mod.	Mb Nm	Zo 1/h	Mod.	Mb Nm	Zo 1/h	Mod.	Mb Nm	Zo 1/h
0.25	BN 71A	2	0.86	61	0.87	0.68	3.9	1.8	1.9	10.9	6.7	FD 03	1.75	1300	1400	12	9.4	FA 03	2.5	1400	12	9.1	BA 70	8	1300	12.9	10.6		
0.06		8	0.84	31	0.61	0.46	2	1.8	1.9				10000	13000						13000					12000				
0.37	BN 71B	2	1.26	63	0.86	0.99	3.9	1.8	1.9	12.9	7.7	FD 03	3.5	1200	1300	14	10.4	FA 03	3.5	1300	14	10.1	BA 70	8	1200	14.9	11.6		
0.09		8	1.28	34	0.75	0.51	1.8	1.4	1.5				9500	13000						13000					12000				
0.55	BN 80A	2	1.86	66	0.86	1.40	4.4	2.1	2.0	20	9.9	FD 04	5	1500	1800	22	13.8	FA 04	5	1800	22	13.7	BA 80	18	1700	23	15.2		
0.13		8	1.80	41	0.64	0.72	2.3	1.6	1.7				5600	8000						8000					7500				
0.75	BN 80B	2	2.6	68	0.88	1.81	4.6	2.1	2.0	25	11.3	FD 04	10	1700	1900	27	15.2	FA 04	10	1900	27	15.1	BA 80	18	1800	28	16.6		
0.18		8	2.5	43	0.66	0.92	2.3	1.6	1.7				4800	7300						7300					7000				
1.1	BN 90L	2	3.7	63	0.84	3.00	4.5	2.1	1.9	28	14	FD 05	13	1400	1600	32	20	FA 05	13	1600	32	21	BA 90	35	1400	35	21		
0.28		8	3.9	48	0.63	1.34	2.4	1.8	1.9				3400	5100						5100					4500				
1.5	BN 100LA	2	5.0	69	0.85	3.69	4.7	1.9	1.8	40	18.3	FD 15	13	1000	1200	44	25	FA 15	13	1200	44	25	BA 100	50	1000	52	29		
0.37		8	5.1	46	0.63	1.84	2.1	1.6	1.6				3300	5000						5000					4200				
2.4	BN 100LB	2	7.9	75	0.82	5.6	5.4	2.1	2.0	61	25	FD 15	26	550	700	65	31	FA 15	26	700	65	32	BA 100	50	600	72	36		
0.55		8	7.5	54	0.58	2.5	2.6	1.8	1.8				2000	3500						3500					3100				
3	BN 112M	2	9.9	76	0.87	6.5	6.3	2.1	1.9	98	30	FD 06S	40	—	900	107	40	FA 06S	40	900	107	42	BA 110	75	800	114	43		
0.75		8	10.4	60	0.65	2.8	2.5	1.6	1.6				—	—	2900					2900					2700				
4	BN 132S	2	13.3	73	0.84	9.4	5.6	2.3	2.4	213	44	FD 56	37	—	500	223	57	FA 06	37	500	223	58	BA 140	150	400	263	76		
1		8	13.8	66	0.62	3.5	2.9	1.9	1.8				—	—	3500					3500					3000				
5.5	BN 132M	2	18.3	75	0.84	12.6	6.1	2.4	2.5	270	53	FD 06	50	—	400	280	66	FA 06	50	400	280	67	BA 140	150	350	320	85		
1.5		8	21	68	0.63	5.1	2.9	1.9	1.9				—	—	2400					2400					2100				





Pn kW		n min ⁻¹	Mh Nm	η %	cos φ	In [400V] A	Is In	Ms Mn	Ma Mn	Jm x 10 ⁻⁴ kgm ²	IMB5 	freno c.c. / d.c. brake G.S.-bremse / frein c.c.						freno c.a. / a.c. brake W.S.-bremse / frein c.a.											
												FD			FA			BA			FD			FA			BA		
												Mod.	Mb Nm	Zo 1/h NB SB	Jm x 10 ⁻⁴ kgm ²	IMB5 	Mod.	Mb Nm	Zo 1/h	Jm x 10 ⁻⁴ kgm ²	IMB5 	Mod.	Mb max Nm	Zo 1/h	Jm x 10 ⁻⁴ kgm ²	IMB5 			
0.55	BN 80B	2 2820	1.86	64	0.89	1.39	4.2	1.6	1.7	25	11.3	FD 04	5	1000	1300	27	15.2	FA 04	5	1300	27	15.1	BA 80	18	1200	28	16.6		
0.09		12 430	2.0	30	0.63	0.69	1.8	1.9	1.8	12000			8000	12000															
0.75	BN 90L	2 2790	2.6	56	0.89	2.17	4.2	1.8	1.7	26	12.6	FD 05	13	1000	1150	30	18.6	FA 05	13	1150	30	19.3	BA 90	35	1050	33	19.9		
0.12		12 430	2.7	26	0.63	1.06	1.7	1.4	1.6	6300			4600	6300															
1.1	BN 100LA	2 2850	3.7	65	0.85	2.87	4.5	1.6	1.8	40	18.3	FD 15	13	700	900	44	25	FA 15	13	900	44	25	BA 100	50	750	52	29		
0.18		12 430	4.0	26	0.54	1.85	1.5	1.3	1.5	6000			4000	6000															
1.5	BN 100LB	2 2900	4.9	67	0.86	3.76	5.6	1.9	1.9	54	22	FD 15	13	700	900	58	28	FA 15	13	900	58	29	BA 100	50	800	66	32		
0.25		12 440	5.4	36	0.46	2.18	1.8	1.7	1.8	5000			3800	5000															
2	BN 112M	2 2900	6.6	74	0.88	4.43	6.5	2.1	2	98	30	FD 06S	20	—	800	107	40	FA 06S	20	800	107	42	BA 110	75	750	114	43		
0.3		12 460	6.2	46	0.43	2.19	2	2.1	2	3400			—	—	3400														
3	BN 132S	2 2920	9.8	74	0.87	6.7	6.8	2.3	1.9	213	44	FD 56	37	—	450	223	57	FA 06	37	450	223	58	BA 140	150	380	263	76		
0.5		12 470	10.2	51	0.43	3.3	2	1.7	1.6	3000			—	—	3000														
4	BN 132M	2 2920	13.1	75	0.89	8.6	5.9	2.4	2.3	270	53	FD 56	37	—	400	280	66	FA 06	37	400	280	67	BA 140	150	350	320	85		
0.7		12 460	14.5	53	0.44	4.3	1.9	1.7	1.6	2800			—	—	2800														





Pn kW		n min ⁻¹	Mn Nm	η %	cos φ	In [400V] A	$\frac{I_s}{I_n}$	$\frac{M_s}{M_n}$	$\frac{M_a}{M_n}$	Jm ⁴ x 10 ⁻⁴ kgm ²	IM B5 	freno c.c. / d.c. brake G.S.-bremse / frein c.c.						freno c.a. / a.c. brake W.S.-bremse / frein c.a.											
												FD			FA			BA			FD			FA			BA		
												Mod.	Mb Nm	Zo 1/h	NB	SB	Jm ⁴ x 10 ⁻⁴ kgm ²	IM B5 	Mod.	Mb Nm	Zo 1/h	Jm ⁴ x 10 ⁻⁴ kgm ²	IM B5 	Mod.	Mb Nm	Zo 1/h	Jm ⁴ x 10 ⁻⁴ kgm ²	IM B5 	
0.22	BN 71B	4	1.5	64	0.74	0.67	3.9	1.8	1.9	9.1	7.3	FD 03	3.5	2500	3500	10.2	10	FA 03	3.5	3500	10.2	9.7	BA 70	8	3200	11.1	11.2		
0.13		6	1.4	43	0.67	0.65	2.3	1.6	1.7				5000	9000						9000				8200					
0.30	BN 80A	4	2.0	61	0.82	0.87	3.5	1.3	1.5	15	8.2	FD 04	5	2500	3100	16.6	12.1	FA 04	5	3100	16.6	12.0	BA 80	18	2800	18	13.5		
0.20		6	2.1	54	0.66	0.81	3.2	1.9	2.0				4000	6000						6000				5500					
0.40	BN 80B	4	2.7	63	0.75	1.22	3.9	1.8	1.8	20	9.9	FD 04	10	1800	2300	22	13.8	FA 04	10	2300	22	13.7	BA 80	18	2200	23	15.2		
0.26		6	2.7	55	0.70	0.97	2.7	1.5	1.6				3600	5500						5500				5200					
0.55	BN 90S	4	3.7	70	0.78	1.45	4.5	2.0	1.9	21	12.2	FD 14	10	1500	2100	23	16.1	FA 14	10	2100	23	16.3	BA 90	35	1700	28	19.5		
0.33		6	3.4	62	0.70	1.10	3.7	2.3	2.0				2500	4100						4100				3300					
0.75	BN 90L	4	5.0	74	0.78	1.88	4.3	1.9	1.8	28	14	FD 05	13	1400	2000	32	20	FA 05	13	2000	32	21	BA 90	35	1800	35	21		
0.45		6	4.7	66	0.71	1.39	3.3	2.0	1.9				2300	3600						3600				3300					
1.1	BN 100LA	4	7.2	74	0.79	2.72	5.0	1.7	1.9	82	22	FD 15	26	1400	2000	86	28	FA 15	26	2000	86	29	BA 100	50	1800	94	32		
0.8		6	8.0	65	0.69	2.57	4.1	1.9	2.1				2100	3300						3300				3000					
1.5	BN 100LB	4	9.9	75	0.79	3.65	5.1	1.7	1.9	95	25	FD 15	26	1300	1800	99	31	FA 15	26	1800	99	32	BA 100	50	1600	107	34		
1.1		6	11.1	72	0.68	3.24	4.3	2.0	2.1				2000	3000						3000				2800					
2.3	BN 112M	4	15.2	75	0.78	5.7	5.2	1.8	1.9	168	32	FD 06S	40	—	1600	177	42	FA 06S	40	1600	177	44	BA 110	75	1500	184	45		
1.5		6	14.9	73	0.72	4.1	4.9	2.0	2.0				—	2400						2400				2300					
3.1	BN 132S	4	20	83	0.83	6.5	5.9	2.1	2.0	213	44	FD 56	37	—	1200	223	57	FA 06	37	1200	223	58	BA 140	150	1000	263	76		
2		6	20	77	0.75	4.9	4.5	2.1	2.1				—	1900						1900				1600					
4.2	BN 132MA	4	27	84	0.82	8.8	5.9	2.1	2.2	270	53	FD 06	50	—	900	280	66	FA 06	50	900	280	67	BA 140	150	800	320	85		
2.6		6	26	79	0.72	6.6	4.3	2.0	2.0				—	1500						1500				1300					

4/8 P**1500/750 min⁻¹ - S1****50 Hz**



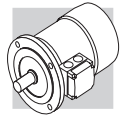

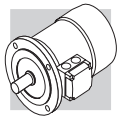







Pn kW		n min ⁻¹	Mh Nm	η %	cos φ	In [400V] A	Is In	Ms Mn	Ma Mn	Jm x 10 ⁻⁴ kgm ²	IM B5 	freno c.c. / d.c. brake G.S.-bremse / frein c.c.				freno c.a. / a.c. brake W.S.-bremse / frein c.a.												
												FD		FA		BA		FA		BA								
												Mod.	Mb Nm	Zo 1/h	Jm x 10 ⁻⁴ kgm ²	IM B5 	Mod.	Mb Nm	Zo 1/h	Jm x 10 ⁻⁴ kgm ²	IM B5 	Mod.	Mb Nm	Zo 1/h	Jm x 10 ⁻⁴ kgm ²	IM B5 		
0.37	BN 80A	4	2.5	63	0.82	1.03	3.3	1.4	1.4	15	8.2	FD 04	10	2300	3500	16.6	12.1	FA 04	10	3500	7000	16.6	12.0	BA 80	18	3200	18	13.5
0.18		8	2.5	44	0.60	0.98	2.2	1.5	1.6				4500	7000												6500		
0.55	BN 80B	4	3.8	65	0.86	1.42	3.8	1.7	1.6	20	9.9	FD 04	10	2200	2900	22	13.8	FA 04	10	2900	5600	22	13.7	BA 80	18	2500	23	15.2
0.30		8	4.3	49	0.65	1.36	2.3	1.7	1.8				4200	6500														
0.65	BN 90S	4	4.5	73	0.85	1.51	4.0	1.9	1.9	28	13.6	FD 14	15	2300	2800	30	17.8	FA 14	15	2800	6000	30	17.7	BA 90	35	2400	35	21
0.35		8	4.8	49	0.57	1.81	2.5	2.1	2.2				3500	6000														
0.9	BN 90L	4	6.3	73	0.87	2.05	3.8	1.8	1.8	30	15.1	FD 05	26	1700	2100	34	21	FA 05	26	2100	4200	34	22	BA 90	35	1900	37	22
0.5		8	7.1	57	0.62	2.04	2.4	2.1	2				2500	4200														
1.3	BN 100LA	4	8.7	72	0.83	3.14	4.3	1.7	1.8	82	22	FD 15	40	1300	1700	86	28	FA 15	40	1700	3400	86	29	BA 100	50	1500	94	32
0.7		8	9.6	58	0.64	2.72	2.8	1.8	1.8				2000	3400														
1.8	BN 100LB	4	12.1	69	0.87	4.3	4.2	1.6	1.7	95	25	FD 15	40	1200	1700	99	31	FA 15	40	1700	2600	99	32	BA 100	50	1500	107	34
0.9		8	12.3	62	0.63	3.3	3.2	1.7	1.8				1600	2600														
2.2	BN 112M	4	14.6	77	0.85	4.9	5.3	1.8	1.8	168	32	FD 06S	60	—	1200	177	42	FA 06S	60	1200	2000	177	43	BA 110	75	1100	184	45
1.2		8	16.1	70	0.63	3.9	3.3	1.9	1.8				—	—	2000													
3.6	BN 132S	4	24	80	0.82	7.9	6.5	2.1	1.9	295	45	FD 56	75	—	1000	305	58	FA 06	75	1000	1400	305	59	BA 140	150	900	345	77
1.8		8	24	72	0.55	6.6	4.6	1.9	2				—	—	1400													
4.6	BN 132M	4	30	81	0.83	9.9	6.5	2.2	1.9	383	56	FD 06	100	—	1000	393	69	FA 07	100	1000	1300	406	74	BA 140	150	900	433	88
2.3		8	31	73	0.54	8.4	4.4	2.3	2				—	—	1300													









Pn kW	Pn kW	n min ⁻¹	Mn Nm	EFF 2	η (100%) %	η (75%) %	cos φ	In [400V] A	Is In	Ms Mn	Ma Mn	Jm x 10 ⁻⁴ kgm ²	IM B9 Kg	freno c.c. / d.c. brake G.S.-bremse / frein c.c.				freno c.a. / a.c. brake W.S.-bremse / frein c.a.						
														Mod.	Mb Nm	Z ₀ 1/h	NB SB	Jm x 10 ⁻⁴ kgm ²	IM B9 Kg	Mod.	Mb Nm	Z ₀ 1/h	Jm x 10 ⁻⁴ kgm ²	IM B9 Kg
0.18	M 05A 2	2730	0.63		59.9	56.9	0.77	0.56	3.0	2.1	2.0	2.0	3.2	FD 02	1.75	3900	4800	2.6	4.9	FA 02	1.75	4800	2.6	4.7
0.25	M 05B 2	2740	0.87		66.0	64.8	0.76	0.72	3.3	2.3	2.3	2.3	3.6	FD 02	1.75	3900	4800	3.0	5.3	FA 02	1.75	4800	3.0	5.1
0.37	M 05C 2	2800	1.26		69.1	66.8	0.78	0.99	3.9	2.6	2.6	3.3	4.8	FD 02	3.5	3600	4500	3.9	6.5	FA 02	3.5	4500	3.9	6.3
0.55	M 15D 2	2820	1.86		76.0	75.8	0.76	1.37	5	2.9	2.8	4.1	5.8	FD 03	5	2900	4200	5.3	8.5	FA 03	5	4200	5.3	8.2
0.75	M 15LA 2	2810	2.6		76.6	76.2	0.76	1.86	5.1	3.1	2.8	5.0	6.9	FD 03	5	1900	3300	6.1	9.6	FA 03	5	3300	6.1	9.3
1.1	M 25A 2	2800	3.8	EFF 2	76.4	76.2	0.81	2.57	4.8	2.8	2.4	9.0	8.8	FD 04	10	1500	3000	10.6	11.9	FA 04	10	3000	10.6	12.6
1.5	M 25B 2	2800	5.1	EFF 2	79.1	79.5	0.81	3.4	4.9	2.7	2.4	11.4	10.6	FD 04	15	1300	2600	13.0	9.9	FA 04	15	2600	13.0	14.4
2.2	M 35A 2	2850	7.4		80.2	80.9	0.78	5.1	5.2	2.1	1.8	24	15.5	FD 15	26	1100	2400	28	22	FA 15	26	2400	28	23
3	M 35LA 2	2860	10.0	EFF 2	82.8	82.6	0.79	6.6	5.7	2.6	2.2	31	18.7	FD 15	26	700	1600	35	25	FA 15	26	1600	35	26
4	M 35LB 2	2870	13.3	EFF 2	84.3	84.4	0.80	8.6	5.9	2.7	2.5	39	22	FD 15	40	450	900	43	28	FA 15	40	900	43	29
5.5	M 45A 2	2890	18.2	EFF 2	86.1	85.7	0.84	11.0	6	2.6	2.2	101	33	FD 06	50	—	600	112	46	FA 06	50	600	112	47
7.5	M 45B 2	2900	25	EFF 2	87.2	87.1	0.85	14.6	6.4	2.6	2.2	145	40	FD 06	50	—	550	154	53	FA 06	50	550	154	54
9.2	M 45LA 2	2930	30	EFF 2	89.0	88.5	0.86	17.3	6.9	2.8	2.3	178	51	FD 56	75	—	430	189	64	FA 06	75	430	189	65
11	M 45LC 2	2920	36	EFF 2	89.1	88.9	0.88	20.2	7	2.9	2.5	210	60											
15	M 55B 2	2930	49	EFF 2	89.6	89.4	0.86	28.1	7.1	2.6	2.3	340	70											
18.5	M 55C 2	2930	60	EFF 2	90.4	90.1	0.86	34	7.6	2.7	2.3	420	83											
22	M 55LA 2	2930	72	EFF 2	91.3	91.3	0.88	40	7.8	2.6	2.4	490	95											

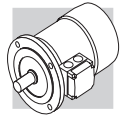

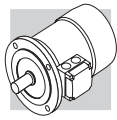

4 P**1500 min⁻¹ - S1****50 Hz**

Pn	kW		n	min ⁻¹	Mn		η (100%)	η (75%)	cos φ	In	$\frac{I_s}{I_n}$	$\frac{M_s}{M_n}$	$\frac{M_a}{M_n}$	$\frac{J_m}{kgm^2}$	IM B9	freno c.c. / d.c. brake G.S.-bremse / frein c.c.				freno c.a. / a.c. brake W.S.-bremse / frein c.a.								
																Mod	Mb	Z _o	Z _o	NB	SB	Mod.	Mb	Z _o	Z _o	IM B9	Jm x 10 ⁻⁴	Jm x 10 ⁻⁴
0.09	M 0B	4	1350	0.64		51.7	47.6	0.60	0.42	2.6	2.5	2.4	1.5	2.9		FD 02	1.75	10000	13000	10000	13000	1.75	13000	2.6	4.9	2.6	4.9	
0.12	M 05A	4	1350	0.85		59.8	56.2	0.62	0.47	2.6	1.9	1.8	2.0	3.2		FD 02	3.5	10000	13000	10000	13000	3.5	13000	3.0	5.3	3.0	5.3	
0.18	M 05B	4	1320	1.30		54.8	52.9	0.67	0.71	2.6	2.2	2.0	2.3	3.6		FD 02	3.5	7800	10000	7800	10000	3.5	10000	3.9	6.5	3.9	6.3	
0.25	M 05C	4	1340	1.78		65.3	65.0	0.69	0.80	2.7	2.1	1.9	3.3	4.8		FD 03	5	6000	9400	6000	9400	5	9400	8.0	8.2	8.0	7.9	
0.37	M 1SD	4	1370	2.6		66.8	66.7	0.76	1.05	3.7	2	1.9	6.9	5.5		FD 53	7.5	4300	8700	4300	8700	7.5	8700	10.2	9.6	10.2	9.3	
0.55	M 1LA	4	1380	3.8		69.0	68.9	0.74	1.55	4.1	2.3	2.3	9.1	6.9		FD 04	15	4100	7800	4100	7800	15	7800	22	13.1	22	13	
0.75	M 2SA	4	1400	5.1		75.0	74.5	0.78	1.85	4.9	2.7	2.5	20	9.2		FD 04	15	2600	5300	2600	5300	15	5300	27	14.5	27	14.4	
1.1	M 2SB	4	1400	7.5		76.4	76.2	0.78	2.66	5.1	2.8	2.5	25	10.6		FD 15	26	2800	4900	2800	4900	26	4900	38	22	38	23	
1.5	M 3SA	4	1410	10.2		79.6	80.5	0.77	3.5	4.6	2.1	2.1	34	15.5		FD 15	40	2600	4700	2600	4700	40	4700	44	24	44	24	
2.2	M 3LA	4	1410	14.9		81.1	81.4	0.75	5.2	4.5	2.2	2	40	17		FD 15	40	2400	4400	2400	4400	40	4400	58	27	58	28	
3	M 3LB	4	1410	20		82.6	83.8	0.77	6.8	5	2.3	2.2	54	21		FD 55	55	—	1300	—	1300	55	1300	65	29	65	30	
4	M 3LC	4	1400	27		82.7	83.1	0.78	9.0	4.7	2.3	2.2	61	23		FD 56	75	—	1050	—	1050	75	1050	223	55	223	56	
5.5	M 4SA	4	1440	36		86.3	86.4	0.80	11.5	5.5	2.3	2.2	213	42		FD 06	100	—	950	—	950	100	950	280	64	280	65	
7.5	M 4LA	4	1440	50		87	87.1	0.80	15.6	5.7	2.5	2.4	270	51		FD 07	150	—	900	—	900	150	900	342	73	342	75	
9.2	M 4LB	4	1440	61		88.4	88.6	0.80	18.8	5.9	2.7	2.5	319	57		FD 07	150	—	850	—	850	150	850	382	81	382	83	
11	M 4LC	4	1440	73		88.4	88.8	0.81	22.2	5.9	2.7	2.5	360	65		FD 08	200	—	750	—	750	200	750	710	115	710	114	
15	M 5SB	4	1460	98		89.9	89.4	0.81	29.7	5.9	2.3	2.1	650	85		FD 08	250	—	700	—	700	250	700	850	131	850	130	
18.5	M 5LA	4	1460	121		90.0	90.1	0.81	37	6.2	2.6	2.5	790	101														









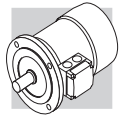

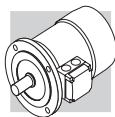

Pn kW		n min ⁻¹	Mn Nm	η %	cos φ	In [400V] A	Is In	Ms Mn	Ma Mn	Jm x 10 ⁻⁴ kgm ²	IM B9  Kg	freno c.c. / d.c. brake G.S.-bremse / frein c.c.						freno c.a. / a.c. brake W.S.-bremse / frein c.a.					
												FD			FA			FD			FA		
												Mod.	Mb Nm	Z ₀ 1/h	SB	IM B9  Kg	Mod.	Mb Nm	Z ₀ 1/h	Jm x 10 ⁻⁴ kgm ²	IM B9  Kg		
0.09	M 05A	880	0.98	41	0.53	0.60	2.1	2.1	1.8	3.4	4.3	FD 02	3.5	9000	14000	6.0	FA 02	3.5	14000	4.0	6.0		
0.12	M 05B	870	1.32	45	0.60	0.64	2.1	1.9	1.7	3.7	4.6	FD 02	3.5	9000	14000	6.3	FA 02	3.5	14000	4.3	6.3		
0.18	M 15C	900	1.91	56	0.69	0.67	2.6	1.9	1.7	8.4	5.1	FD 03	5	8100	13500	7.8	FA 03	5	13500	9.5	7.8		
0.25	M 15D	900	2.7	62	0.71	0.82	2.6	1.9	1.7	10.9	6.3	FD 03	5	7800	13000	9	FA 03	5	13000	12	9		
0.37	M 15LA	910	3.9	66	0.69	1.17	3	2.4	2	12.9	7.3	FD 53	7.5	5100	9500	10	FA 03	7.5	9500	14	10		
0.55	M 25A	920	5.7	70	0.69	1.64	3.9	2.6	2.2	25	10.6	FD 04	15	4800	7200	14.5	FA 04	15	7200	27	14.5		
0.75	M 25B	920	7.8	70	0.65	2.38	3.8	2.5	2.2	28	11.5	FD 04	15	3400	6400	15.4	FA 04	15	6400	30	15.4		
1.1	M 35A	920	11.4	72	0.69	3.2	3.9	2.3	2	33	17	FD 05	26	2700	5000	23	FA 15	26	5000	37	23		
1.5	M 35LA	940	15.2	73	0.72	4.1	4	2.1	2	82	21	FD 15	40	1900	4100	27	FA 15	40	4100	86	27		
1.85	M 35LB	930	19.0	75	0.73	4.9	4.5	2.1	2	95	23	FD 15	40	1700	3600	29	FA 15	40	3600	99	29		
2.2	M 35LC	930	23	75	0.71	6.0	4.6	2	1.9	95	23	FD 55	55	—	1900	29	FA 15	55	1900	99	29		
3	M 45A	940	30	76	0.76	7.5	4.8	1.9	1.8	216	34	FD 56	75	—	1400	47	FA 06	75	1400	226	47		
4	M 45LA	950	40	78	0.77	9.6	5.5	2	1.8	295	43	FD 06	100	—	1200	56	FA 07	100	1200	305	56		
5.5	M 45LB	945	56	80	0.78	12.7	5.9	2.1	1.9	383	54	FD 07	150	—	1050	70	FA 07	150	1050	406	70		
7.5	M 55A	955	75	84	0.81	15.9	5.9	2.2	2	740	69	FD 08	170	—	900	98	FA 08	170	900	800	98		
11	M 55B	960	109	87	0.81	22.5	6.5	2.5	2.3	970	89	FD 08	200	—	800	119	FA 08	200	800	1030	119		

Pn kW		n min ⁻¹	Mn Nm	η %	cos φ	In [400V] A	Is In	Ms Mn	Ma Mn	Jm ⁴ kgm ²	IM B9 	freno c.c. / d.c. brake G.S.-bremse / frein c.c.						freno c.a. / a.c. brake W.S.-bremse / frein c.a.							
												Mod.	Mb Nm	Zo 1/h	NB	SB	Jm ⁴ kgm ²	IM B9 	Mod.	Mb Nm	Zo 1/h	Jm ⁴ kgm ²	IM B9 		
0.20	M 05A	2700	0.71	55	0.82	0.64	3.5	2.1	1.9	2.9	4.1	FD 02	3.5	2200	2600	4000	5100	3.5	5.8	FA 02	3.5	2600	5100	3.5	5.6
0.15	M 15B	1350	1.06	49	0.67	0.66	2.6	1.8	1.7	4.7	4	FD 03	3.5	2100	2400	3800	4800	5.8	6.7	FA 03	3.5	2400	4800	5.8	6.4
0.28	M 15C	2700	0.99	56	0.82	0.88	2.9	1.9	1.7	5.8	4.7	FD 03	5	1400	2100	2900	4200	6.9	7.4	FA 03	5	2100	4200	6.9	7.1
0.20	M 15D	1370	1.39	59	0.68	1.02	3.1	1.8	1.7	6.9	5.5	FD 03	5	1400	2100	2900	4200	8	8.2	FA 03	5	2100	4200	8	7.9
0.37	M 15E	2740	1.29	56	0.82	1.16	3.5	1.8	1.8	9.1	6.9	FD 03	5	1600	2200	3300	4600	10.2	9.6	FA 03	5	2200	4600	10.2	9.3
0.25	M 15F	1390	1.72	60	0.73	0.82	3.3	2	1.9	20	9.2	FD 04	10	1400	1600	2700	3600	22	13.1	FA 04	10	1600	3600	22	13
0.45	M 15G	2780	1.55	63	0.85	1.21	3.8	1.8	1.8	25	10.7	FD 04	10	1200	1500	2300	3100	27	14.5	FA 04	10	1500	3100	27	14.5
0.30	M 15H	1400	2.0	63	0.74	0.93	3.8	2.1	1.9	34	15.5	FD 15	26	700	1000	1600	2600	38	22	FA 15	26	1000	2600	38	23
0.55	M 15I	2800	1.9	73	0.79	1.38	4.2	2	1.8	40	17	FD 15	26	600	900	1300	2300	44	24	FA 15	26	900	2300	44	24
0.37	M 25A	1400	2.5	68	0.72	1.09	3.9	2.2	2	61	23	FD 15	40	500	900	1000	2100	65	29	FA 15	40	900	2100	65	30
0.75	M 25B	2730	3.9	65	0.86	2.84	3.9	2	1.9	213	42	FD 06	50	—	—	—	—	233	55	FA 06	50	400	950	233	56
1.1	M 25C	1410	5.1	75	0.81	1.78	4.5	2.1	2	213	42	FD 06	75	—	—	—	—	223	55	FA 06	75	350	900	223	56
1.5	M 25D	2830	5.1	74	0.83	3.5	4.7	2.1	2	270	51	FD 06	100	—	—	—	—	280	64	FA 07	100	350	950	280	65
1.1	M 35A	1420	7.4	77	0.78	2.6	4.3	2.1	2	319	57	FD 07	150	—	—	—	—	342	73	FA 07	150	300	800	342	75
2.2	M 35B	2800	7.5	72	0.85	5.2	4.5	2	1.9	48	85														
1.5	M 35C	1410	10.2	73	0.79	3.8	4.7	2	2																
3.5	M 35D	2850	11.7	80	0.84	7.5	5.4	2.2	2.1																
2.5	M 4 SA	1420	16.8	82	0.80	5.5	5.2	2.2	2.2																
4.8	M 4 SB	2900	15.8	81	0.88	9.7	6	2	1.9																
3.8	M 4 SC	1430	25.4	81	0.84	8.1	5.2	2.1	2.1																
5.5	M 4 SD	2890	18.2	80	0.87	11.4	5.9	2.4	2																
4.4	M 4 LA	1440	29	82	0.84	9.2	5.3	2.2	2																
7.5	M 4 LB	2900	25	82	0.87	15.2	6.5	2.4	2																
6	M 4 LC	1430	40	84	0.85	12.1	5.8	2.3	2.1																
9.2	M 4 LD	2920	30	83	0.86	18.6	6	2.6	2.2																
7.3	M 4 LE	1440	48	85	0.85	14.6	5.5	2.3	2.1																







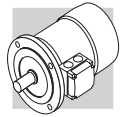

Pn kW		n min ⁻¹	Mn Nm	η %	cos φ	In [400V] A	$\frac{I_s}{I_n}$	$\frac{M_s}{M_n}$	$\frac{M_a}{M_n}$	$\frac{J_m}{kgm^2}$	IM B9  Kg	freno c.c. / d.c. brake G.S.-bremse / frein c.c.						freno c.a. / a.c. brake W.S.-bremse / frein c.a.					
												FD			FA								
												Mod.	Mb Nm	Z ₀ 1/h	$\frac{J_m}{kgm^2}$	IM B9  Kg	Mod.	Mb Nm	Z ₀ 1/h	$\frac{J_m}{kgm^2}$	IM B9  Kg		
0.25	M1SA	2	0.84	60	0.82	0.73	4.3	1.9	1.8	6.9	5.5	FD 03	1.75	1500	1700	8	8.2	FA 03	1.75	1700	8	7.9	
0.08		6	0.84	43	0.70	0.38	2.1	1.4	1.5				10000	13000						13000			
0.37	M1LA	2	1.23	62	0.80	1.08	4.4	1.9	1.8	9.1	6.9	FD 03	3.5	1000	1300	10.2	9.6	FA 03	3.5	1300	10.2	9.3	
0.12		6	1.27	44	0.73	0.54	2.4	1.4	1.5				9000	11000						11000			
0.55	M2SA	2	1.88	63	0.86	1.47	4.5	1.9	1.7	20	9.2	FD 04	5	1500	1800	22	13.1	FA 04	5	1800	22	13	
0.18		6	1.85	52	0.65	0.77	3.3	2.0	1.9				4100	6300						6300			
0.75	M2SB	2	2.6	66	0.87	1.89	4.3	1.8	1.6	25	10.6	FD 04	5	1700	1900	27	14.5	FA 04	5	1900	27	14.4	
0.25		6	2.6	54	0.67	1.00	3.2	1.7	1.8				3800	6000						6000			
1.1	M3SA	2	3.7	71	0.82	2.73	4.9	1.8	1.9	34	15.5	FD 15	13	1000	1300	38	22	FA 15	13	1300	38	23	
0.37		6	3.8	63	0.70	1.21	3.1	1.5	1.8				3500	5000						5000			
1.5	M3LA	2	5.0	73	0.84	3.53	5.1	1.9	2.0	40	17	FD 15	13	1000	1200	44	24	FA 15	13	1200	44	24	
0.55		6	5.6	64	0.67	1.85	3.5	1.7	1.8				2900	4000						4000			
2.2	M3LB	2	7.2	77	0.85	4.9	5.9	2.0	2.0	61	23	FD 15	26	700	900	65	29	FA 15	26	900	65	30	
0.75		6	7.5	67	0.64	2.5	3.3	1.9	1.8				2100	3000						3000			
3	M4SA	2	9.9	74	0.88	6.6	5.6	2.0	2.1	170	36	FD 56	37	—	600	182	48	FA 06	37	600	182	50	
1.1		6	10.9	73	0.68	3.2	4.5	2.2	2				—	2200					2200				
4.5	M4SB	2	14.8	78	0.84	9.9	5.8	1.9	1.8	213	42	FD 56	37	—	500	223	55	FA 06	37	500	223	56	
1.5		6	14.9	74	0.67	4.4	4.2	1.9	2.0				—	2100					2100				
5.5	M4LA	2	18.0	78	0.87	11.7	6.2	2.1	1.9	270	51	FD 06	50	—	400	280	64	FA 06	50	400	280	65	
2.2		6	22	77	0.71	5.8	4.3	2.1	2.0				—	1900					1900				

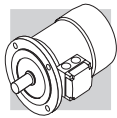
Pn kW		n min ⁻¹	Mn Nm	η %	cos φ	In [400V] A	Is In	Ms Mn	Ma Mn	Jm ⁴ x 10 ⁻⁴ kgm ²	IM B9 	freno c.c. / d.c. brake G.S.-bremse / frein c.c.						freno c.a. / a.c. brake W.S.-bremse / frein c.a.					
												Mod.	Mb Nm	Zo 1/h	NB SB	Jm ⁴ x 10 ⁻⁴ kgm ²	IM B9 	Mod.	Mb Nm	Zo 1/h	Jm ⁴ x 10 ⁻⁴ kgm ²	IM B9 	
0.37	M 1LA	2800	1.26	63	0.86	0.99	3.9	1.8	1.9	12.9	7.3	FD 03	3.5	1200	1300	14	10	FA 03	3.5	1300	14	9.7	
0.09		670	1.28	34	0.75	0.51	1.8	1.4	1.5				9500	13000					13000				
0.55	M 2SA	2830	1.86	66	0.86	1.40	4.4	2.1	2	20	9.2	FD 04	5	1500	1800	22	13.1	FA 04	5	1800	22	13	
0.13		690	1.80	41	0.64	0.72	2.3	1.6	1.7				5600	8000					8000				
0.75	M 2SB	2800	2.6	68	0.88	1.81	4.6	2.1	2	25	10.6	FD 04	10	1700	1900	27	14.5	FA 04	10	1900	27	14.4	
0.18		690	2.5	43	0.66	0.92	2.3	1.6	1.7				4800	7300					7300				
1.1	M 3SA	2870	3.7	69	0.84	2.74	4.6	1.8	1.7	34	15.5	FD 15	13	1000	1300	38	22	FA 15	13	1300	38	23	
0.28		690	3.9	44	0.56	1.64	2.3	1.4	1.7				3400	5000					5000				
1.5	M 3LA	2880	5.0	69	0.85	3.69	4.7	1.9	1.8	40	17	FD 15	13	1000	1200	44	24	FA 15	13	1200	44	24	
0.37		690	5.1	46	0.63	1.84	2.1	1.6	1.6				3300	5000					5000				
2.4	M 3LB	2900	7.9	75	0.82	5.6	5.4	2.1	2	61	23	FD 15	26	550	700	65	29	FA 15	26	700	65	30	
0.55		700	7.5	54	0.58	2.5	2.6	1.8	1.8				2000	3500					3500				
3	M 4SA	2920	9.8	72	0.85	7.1	5.6	2	1.8	162	36	FD 56	37	—	600	182	48	FA 06	37	600	182	50	
0.75		710	10.1	61	0.64	2.8	3	1.7	1.8				—	—	3400				3400				
4	M 4SB	2870	13.3	73	0.84	9.4	5.6	2.3	2.4	213	42	FD 56	37	—	500	223	55	FA 06	37	500	223	56	
1		690	13.8	66	0.62	3.5	2.9	1.9	1.8				—	—	3500				3500				
5.5	M 4LA	2870	18.3	75	0.84	12.6	6.1	2.4	2.5	270	51	FD 06	50	—	400	280	64	FA 06	50	400	280	65	
1.5		690	21	68	0.63	5.1	2.9	1.9	1.9				—	—	2400				2400				





Pn kW		n min ⁻¹	Mn Nm	η %	cos φ	In [400V] A	Is In	Ms Mn	Ma Mn	Jm x 10 ⁻⁴ kgm ²	IM B9 	freno c.c. / d.c. brake G.S.-bremse / frein c.c.						freno c.a. / a.c. brake W.S.-bremse / frein c.a.					
												Mod.	Mb Nm	Zo 1/h	NB SB	Jm x 10 ⁻⁴ kgm ²	IM B9 	Mod.	Mb Nm	Zo 1/h	Jm x 10 ⁻⁴ kgm ²	IM B9 	
0.55	M 2SA	2820	1.86	64	0.89	1.39	4.2	1.6	1.7	25	10.6	FD 04	5	1000	1300	27	14.5	FA 04	5	1300	27	14.4	
0.09		430	2.0	30	0.63	0.69	1.8	1.9	1.8					8000	12000						12000		
0.75	M 3SA	2900	2.5	65	0.81	2.06	5.2	1.9	2.1	34	15.5	FD 15	13	700	900	38	22	FA 15	13	900	38	23	
0.12		460	2.5	33	0.43	1.22	1.9	1.3	1.6					5000	7000					7000			
1.1	M 3LA	2850	3.7	65	0.85	2.87	4.5	1.6	1.8	40	17	FD 15	13	700	900	44	24	FA 15	13	900	44	24	
0.18		430	4.0	26	0.54	1.85	1.5	1.3	1.5					4000	6000					6000			
1.5	M 3LB	2900	4.9	67	0.86	3.76	5.6	1.9	1.9	54	21	FD 15	13	700	900	58	27	FA 15	13	900	58	28	
0.25		440	5.4	36	0.46	2.18	1.8	1.7	1.8					3800	5000					5000			
2	M 3LC	2850	6.7	70	0.84	4.9	4.9	1.8	1.7	61	23	FD 55	18	—	700	65	29	FA 15	18	700	65	30	
0.3		450	6.4	38	0.47	2.4	1.7	1.6	1.7					—	3500					3500			
3	M 4SA	2920	9.8	74	0.87	6.7	6.8	2.3	1.9	213	42	FD 56	37	—	450	223	55	FA 06	37	450	223	56	
0.5		470	10.2	51	0.43	3.3	2	1.7	1.6					—	3000					3000			
4	M 4LA	2920	13.1	75	0.89	8.6	5.9	2.4	2.3	270	51	FD 56	37	—	400	280	64	FA 06	37	400	280	65	
0.7		460	14.5	53	0.44	4.3	1.9	1.7	1.6					—	2800					2800			

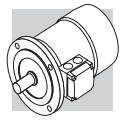

M12 - DIMENSIONI MOTORI

M12 - MOTORS DIMENSIONS

M12 - MOTORENABMESSUN-
GEN

*M12 - DIMENSIONS
MOTEURS*

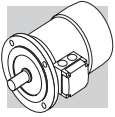

BN

IM B14

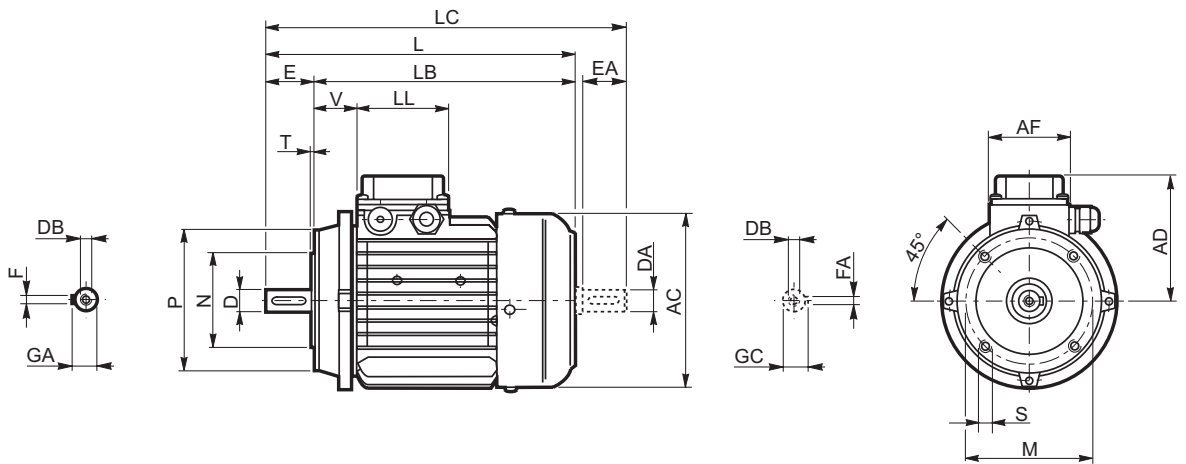

	Albero / Shaft / Welle / Arbre					Flangia / Flange / Flansch / Bride					Motore / Motor / Motor / Moteur							
	D DA	E EA	DB	GA GC	F FA	M	N	P	S	T	AC	L	LB	LC	AD	AF	LL	V
BN 56	9	20	M3	10.2	3	65	50	80	M5	2.5	110	185	165	207	91	74	80	34
BN 63	11	23	M4	12.5	4	75	60	90	M5	2.5	121	207	184	232	95	74	80	26
BN 71	14	30	M5	16	5	85	70	105	M6	2.5	138	249	219	281	108	74	80	37
BN 80	19	40	M6	21.5	6	100	80	120	M6	3	156	274	234	315	119	74	80	38
BN 90	24	50	M8	27	8	115	95	140	M8	3	176	326	276	378	133	98	98	44
BN 100	28	60	M10	31	8	130	110	160	M8	3.5	195	366	306	429	142	98	98	50
BN 112	28	60	M10	31	8	130	110	160	M8	3.5	219	385	325	448	157	98	98	52
BN 132	38	80	M12	41	10	165	130	200	M10	4	258	493	413	576	193	118	118	58

N.B.:

1) Queste dimensioni sono riferite alla seconda estremità d'albero.

NOTE:

1) These values refer to the rear shaft end.

HINWEIS:

1) Diese Maße betreffen das zweite Wellenende.

REMARQUE :

1) Ces dimensions se réfèrent à la deuxième extrémité de l'arbre.

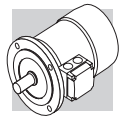

BN

IM B5

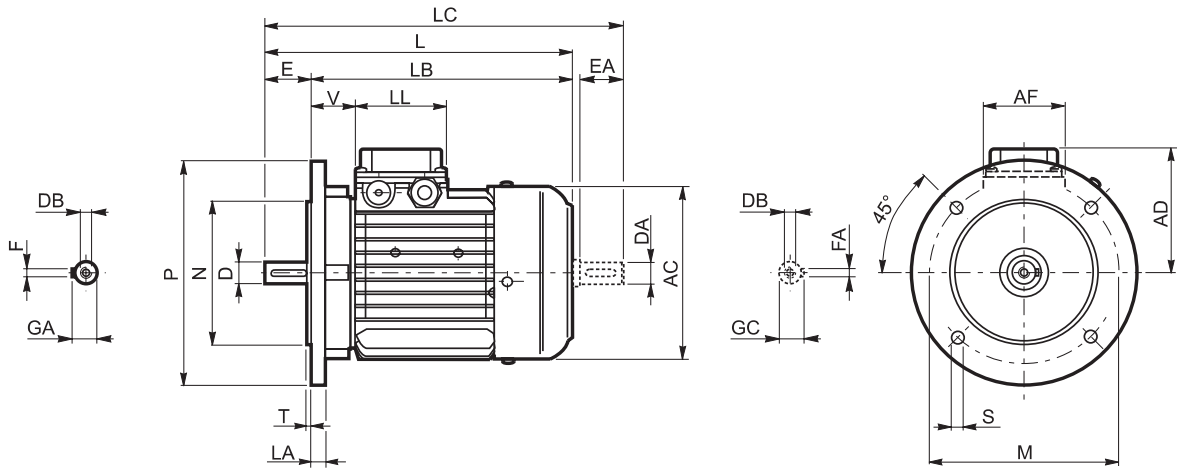

	Albero / Shaft / Welle / Arbre					Flangia / Flange / Flansch / Bride						Motore / Motor / Motor / Moteur							
	D DA	E EA	DB	GA GC	F FA	M	N	P	S	T	LA	AC	L	LB	LC	AD	AF	LL	V
BN 56	9	20	M3	10.2	3	100	80	120	7	3	8	110	185	165	207	91	74	80	34
BN 63	11	23	M4	12.5	4	115	95	140	9.5	3	10	121	207	184	232	95	74	80	26
BN 71	14	30	M5	16	5	130	110	160	9.5	3	10	138	249	219	281	108	74	80	37
BN 80	19	40	M6	21.5	6	165	130	200	11.5	3.5	11.5	156	274	234	315	119	74	80	38
BN 90	24	50	M8	27	8	165	130	200	11.5	3.5	11.5	176	326	276	378	133	98	98	44
BN 100	28	60	M10	31	8	215	180	250	14	4	14	195	367	307	429	142	98	98	50
BN 112	28	60	M10	31	8	215	180	250	14	4	15	219	385	325	448	157	98	98	52
BN 132	38	80	M12	41	10	265	230	300	14	4	16	258	493	413	576	193	118	118	58
BN 160 MR	42 38 (1)	110 80 (1)	M16 M12 (1)	45 41 (1)	12 10 (1)	300	250	350	18.5	5	15	258	562	452	645	193	118	118	218
BN 160 M	42 38 (1)	110 80 (1)	M16 M12 (1)	45 41 (1)	12 10 (1)	300	250	350	18.5	5	15	310	596	486	680	245	187	187	51
BN 160 L	42 38 (1)	110 80 (1)	M16 M12 (1)	45 41 (1)	12 10 (1)	300	250	350	18.5	5	15	310	596	486	680	245	187	187	51
BN 180 M	48 38 (1)	110 110 (1)	M16 M12 (1)	51.5 41 (1)	14 10 (1)	300	250	350	18.5	5	15	310	640	530	724	245	187	187	51
BN 180 L	48 42 (1)	110 110 (1)	M16 M16 (1)	51.5 45 (1)	14 12 (1)	300	250	350	18.5	5	18	348	708	598	823	261	187	187	52
BN 200 L	55 42 (1)	110 110 (1)	M20 M16 (1)	59 45 (1)	16 12 (1)	350	300	400	18.5	5	18	348	722	612	837	261	187	187	66

N.B.:

1) Queste dimensioni sono riferite alla seconda estremità d'albero.

NOTE:

1) These values refer to the rear shaft end.

HINWEIS:

1) Diese Maße betreffen das zweite Wellenende.

REMARQUE :

1) Ces dimensions se réfèrent à la deuxième extrémité de l'arbre.

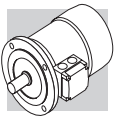

BN_FD

IM B14

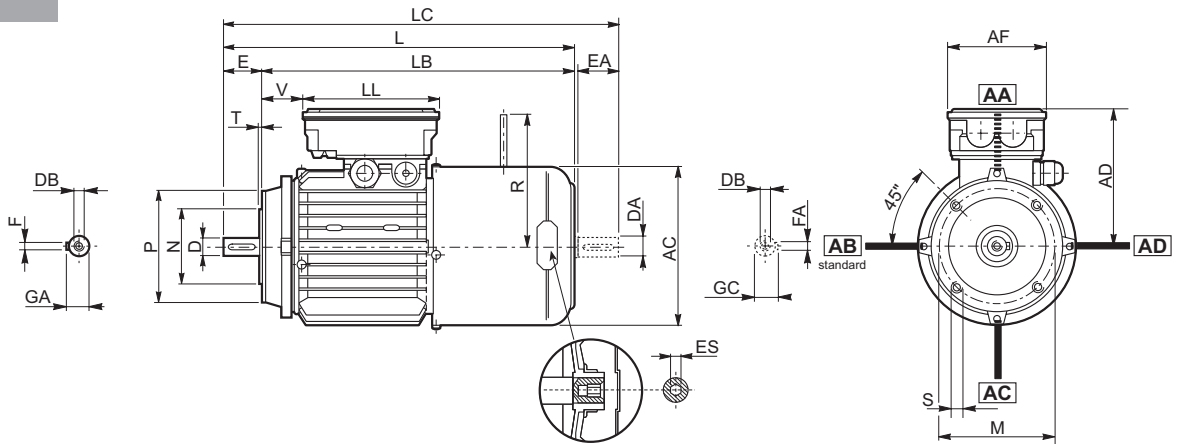

	Albero / Shaft / Welle / Arbre					Flangia / Flange / Flansch / Bride					Motore / Motor / Motor / Moteur									
	D DA	E EA	DB	GA GC	F FA	M	N	P	S	T	AC	L	LB	LC	AD	AF	LL	V	R	ES
BN 63	11	23	M4	12.5	4	75	60	90	M5	2.5	121	272	249	297	119	98	133	14	96	5
BN 71	14	30	M5	16	5	85	70	105	M6	2.5	138	310	280	342	132	98	133	30	103	5
BN 80	19	40	M6	21.5	6	100	80	120	M6	3	156	346	306	388	143	98	133	41	129	5
BN 90	24	50	M8	27	8	115	95	140	M8	3	176	409	359	461	146	110	165	39	160	6
BN 100	28	60	M10	31	8	130	110	160	M8	3.5	195	458	398	521	155	110	165	62	160	6
BN 112	28	60	M10	31	8	130	110	160	M8	3.5	219	484	424	547	170	110	165	73	199	6
BN 132	38	80	M12	41	10	165	130	200	M10	4	258	603	523	686	193	118	118	180	204 (2)	6

N.B.:

- 1) Queste dimensioni sono riferite alla seconda estremità d'albero.
- 2) Per freno FD07 quota R=226.

NOTE:

- 1) These values refer to the rear shaft end.
- 2) For FD07 brake value R=226.

HINWEIS:

- 1) Diese Maße betreffen das zweite Wellenende.
- 2) Für Bremse FD07, Maß R=226.

REMARQUE :

- 1) Ces dimensions se réfèrent à la deuxième extrémité de l'arbre.
- 2) Pour frein FD07 valeur R=226.

L'esagono ES non è presente con l'opzione PS.

ES hexagon is not supplied with PS option.

Der Sechskant ES ist bei der Option PS nicht vorhanden.

L'hexagone ES n'est pas disponible avec l'option PS.

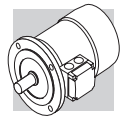

BN_FD

IM B5

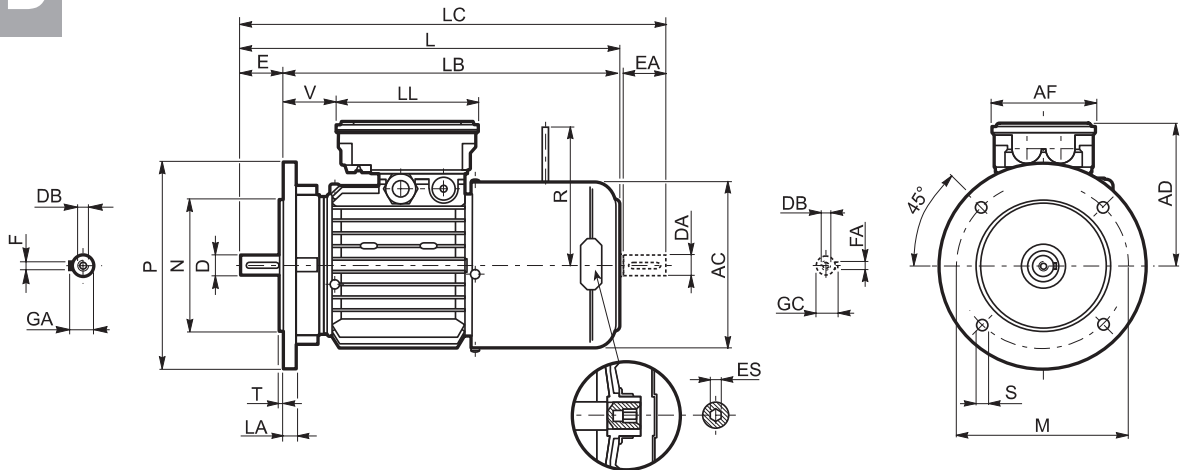

	Albero / Shaft / Welle / Arbre					Flangia / Flange / Flansch / Bride						Motore / Motor / Motor / Moteur									
	D DA	E EA	DB	GA GC	F FA	M	N	P	S	T	LA	AC	L	LB	LC	AD	AF	LL	V	R	ES
BN 63	11	23	M4	12.5	4	115	95	140	9.5	3	10	121	272	249	297	119	98	133	14	96	5
BN 71	14	30	M5	16	5	130	110	160	9.5	3.5	10	138	310	280	342	132	98	133	30	103	5
BN 80	19	40	M6	21.5	6	165	130	200	11.5	3.5	11.5	156	346	306	388	143	98	133	41	129	5
BN 90	24	50	M8	27	8	165	130	200	11.5	3.5	11.5	176	409	359	461	146	110	165	39	160	6
BN 100	28	60	M10	31	8	215	180	250	14	4	14	195	458	398	521	155	110	165	62	160	6
BN 112	28	60	M10	31	8	215	180	250	14	4	15	219	484	424	547	170	110	165	73	199	6
BN 132	38	80	M12	41	10	265	230	300	14	4	16	258	603	523	686	193	118	118	180	204 (2)	6
BN 160 MR	42 38 (1)	110 80 (1)	M16 M12 (1)	45 41 (1)	12 10 (1)	300	250	350	18.5	5	15	258	672	562	755	193	118	118	218	226	6
BN 160 M	42 38 (1)	110 80 (1)	M16 M12 (1)	45 41 (1)	12 10 (1)	300	250	350	18.5	5	15	310	736	626	820	245	187	187	51	266	
BN 160 L	42 38 (1)	110 80 (1)	M16 M12 (1)	45 41 (1)	12 10 (1)	300	250	350	18.5	5	15	310	736	626	820	245	187	187	51	266	
BN 180 M	48 38 (1)	110 110 (1)	M16 M12 (1)	51.5 41 (1)	14 10 (1)	300	250	350	18.5	5	15	310	780	670	864	245	187	187	51	266	
BN 180 L	48 42 (1)	110 110 (1)	M16 M16 (1)	51.5 45 (1)	14 12 (1)	300	250	350	18.5	5	18	348	866	756	981	261	187	187	52	305	
BN 200 L	55 42 (1)	110 110 (1)	M20 M16 (1)	59 45 (1)	16 12 (1)	350	300	400	18.5	5	18	348	878	768	993	261	187	187	64	305	

N.B.:

- 1) Queste dimensioni sono riferite alla seconda estremità d'albero.
- 2) Per freno FD07 quota R=226.

NOTE:

- 1) These values refer to the rear shaft end.
- 2) For FD07 brake value R=226.

HINWEIS:

- 1) Diese Maße betreffen das zweite Wellenende.
- 2) Für Bremse FD07, Maß R=226.

REMARQUE :

- 1) Ces dimensions se réfèrent à la deuxième extrémité de l'arbre.
- 2) Pour frein FD07 valeur R=226.

L'esagono ES non è presente con l'opzione PS.

ES hexagon is not supplied with PS option.

Der Sechskant ES ist bei der Option PS nicht vorhanden.

L'hexagone ES n'est pas disponible avec l'option PS.

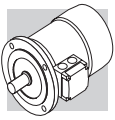

BN_FA

IM B14

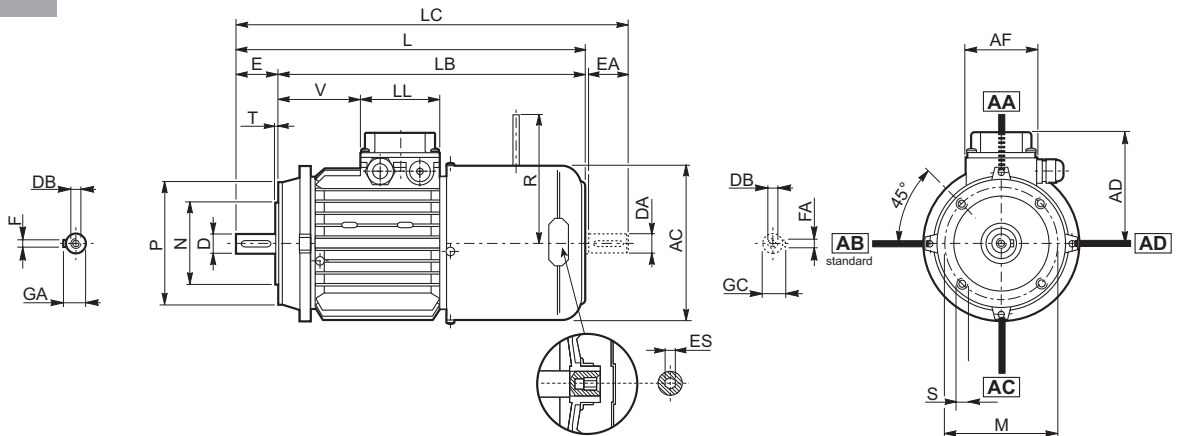

	Albero / Shaft / Welle / Arbre					Flangia / Flange / Flansch / Bride					Motore / Motor / Motor / Moteur									
	D DA	E EA	DB	GA GC	F FA	M	N	P	S	T	AC	L	LB	LC	AD	AF	LL	V	R	ES
BN 63	11	23	M4	12.5	4	75	60	90	M5	2.5	121	272	249	119	95	74	80	26	116	5
BN 71	14	30	M5	16	5	85	70	105	M6	2.5	138	310	280	342	108	74	80	68	124	5
BN 80	19	40	M6	21.5	6	100	80	120	M6	3	156	346	306	388	119	74	80	83	134	5
BN 90	24	50	M8	27	8	115	95	140	M8	3	176	409	359	461	133	98	98	95	160	6
BN 100	28	60	M10	31	8	130	110	160	M8	3.5	195	458	398	521	142	98	98	119	160	6
BN 112	28	60	M10	31	8	130	110	160	M8	3.5	219	484	424	547	157	98	98	128	198	6
BN 132	38	80	M12	41	10	165	130	200	M10	4	258	603	523	686	193	118	118	180	200 (2)	6

N.B.:

- 1) Queste dimensioni sono riferite alla seconda estremità d'albero.
- 2) Per freno FD07 quota R=226.

NOTE:

- 1) These values refer to the rear shaft end.
- 2) For FD07 brake value R=226.

HINWEIS:

- 1) Diese Maße betreffen das zweite Wellenende.
- 2) Für Bremse FD07, Maß R=226.

REMARQUE :

- 1) Ces dimensions se réfèrent à la deuxième extrémité de l'arbre.
- 2) Pour frein FD07 valeur R=226.

Per la versione BN..FA le dimensioni della scatola morsetti AD, AF, LL, V sono uguali al tipo BN..FD.

For motors type BN..FA, the terminal box sizes AD, AF, LL, V are the same as for BN..FD.

Bei der Motor typ BN..FA sind die Maße des Klemmenkastens AD, AF, LL, V denen der Version BN..FD gleich.

Pour moteurs type BN..FA les dimensions de la boîte à bornes AD, AF, LL, V sont les mêmes de BN..FD.

L'esagono ES non è presente con l'opzione PS.

ES hexagon is not supplied with PS option.

Der Sechskant ES ist bei der Option PS nicht vorhanden.

L'hexagone ES n'est pas disponible avec l'option PS.

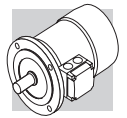

BN_FA

IM B5

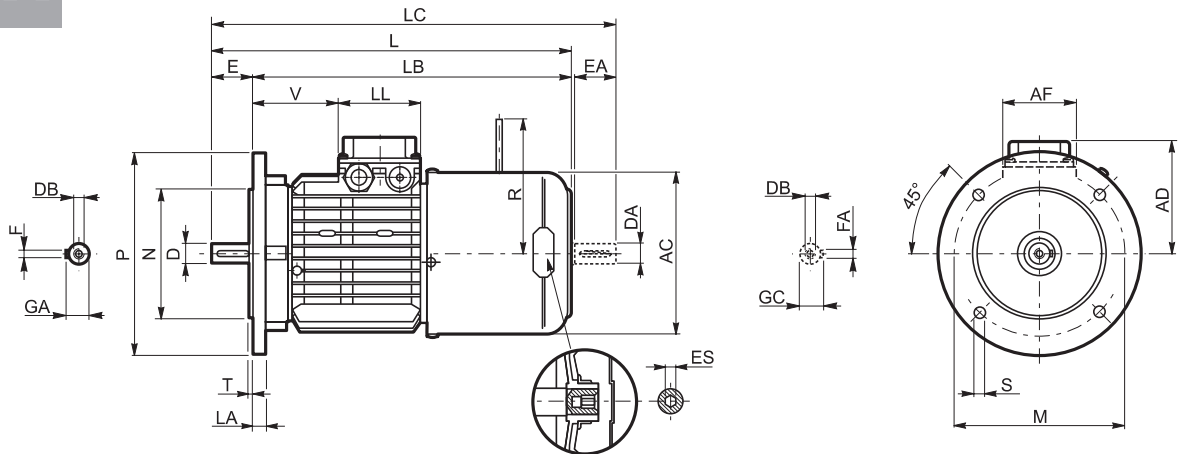

	Albero / Shaft / Welle / Arbre					Flangia / Flange / Flansch / Bride						Motore / Motor / Motor / Moteur									
	D DA	E EA	DB	GA GC	F FA	M	N	P	S	T	LA	AC	L	LB	LC	AD	AF	LL	V	R	ES
BN 63	11	23	M4	12.5	4	115	95	140	9.5	3	10	121	272	249	297	95	74	80	26	116	5
BN 71	14	30	M5	16	5	130	110	160	9.5	3.5	10	138	310	280	342	108	74	80	68	124	5
BN 80	19	40	M6	21.5	6	165	130	200	11.5	3.5	11.5	156	346	306	388	119	74	80	83	134	5
BN 90	24	50	M8	27	8	165	130	200	11.5	3.5	11.5	176	409	359	461	133	98	98	95	160	6
BN 100	28	60	M10	31	8	215	180	250	14	4	14	195	458	398	521	142	98	98	119	160	6
BN 112	28	60	M10	31	8	215	180	250	14	4	15	219	484	424	547	157	98	98	128	198	6
BN 132	38	80	M12	41	10	265	230	300	14	4	16	258	603	523	686	193	118	118	180	200 (2)	6
BN 160 MR	42 38 (1)	110 80 (1)	M16 M12 (1)	45 41 (1)	12 10 (1)	300	250	350	18.5	5	15	258	672	562	755	193	118	118	218	217	6
BN 160 M	42 38 (1)	110 80 (1)	M16 M12 (1)	45 41 (1)	12 10 (1)	300	250	350	18.5	5	15	310	736	626	820	245	187	187	51	247	—
BN 160 L	42 38 (1)	110 80 (1)	M16 M12 (1)	45 41 (1)	12 10 (1)	300	250	350	18.5	5	15	310	736	626	820	245	187	187	51	247	—
BN 180 M	48 38 (1)	110 80 (1)	M16 M12 (1)	51.5 41 (1)	14 10 (1)	300	250	350	18.5	5	15	310	780	670	864	245	187	187	51	247	—

N.B.:

- 1) Queste dimensioni sono riferite alla seconda estremità d'albero.
- 2) Per freno FD07 quota R=226.

NOTE:

- 1) These values refer to the rear shaft end.
- 2) For FD07 brake value R=226.

HINWEIS:

- 1) Diese Maße betreffen das zweite Wellenende.
- 2) Für Bremse FD07, Maß R=226.

REMARQUE :

- 1) Ces dimensions se réfèrent à la deuxième extrémité de l'arbre.
- 2) Pour frein FD07 valeur R=226.

Le dimensioni AD, AF, LL e V relative alla scatola morsetteria dei motori BN...FA dotati di alimentazione separata del freno (opzione SA) coincidono con quelle dei motori BN...FD di pari taglia.

Dimensions AD, AF, LL and V, relevant to terminal box of motors BN...FA featuring the separate brake supply (option SA), are coincident with corresponding dimensions of same-size BN...FD motors.

Die Abmessungen des Klemmenkastens der Motoren BN ... FA AD, AF, LL und V in bezug auf die separate Spannungsversorgung (Option SA) stimmen mit den Abmessungen der entsprechenden Motoren BN...FD überein.

Les dimensions AD, AF, LL et V relatives à la boîte à borne des moteurs BN...FA équipés d'alimentation séparée du frein (option SA) sont identiques à celles des moteurs BN...FD de la même taille.

L'esagono ES non è presente con l'opzione PS.

ES hexagon is not supplied with PS option.

Der Sechskant ES ist bei der Option PS nicht vorhanden.

L'hexagone ES n'est pas disponible avec l'option PS.

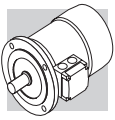

BN_BA

IM B14

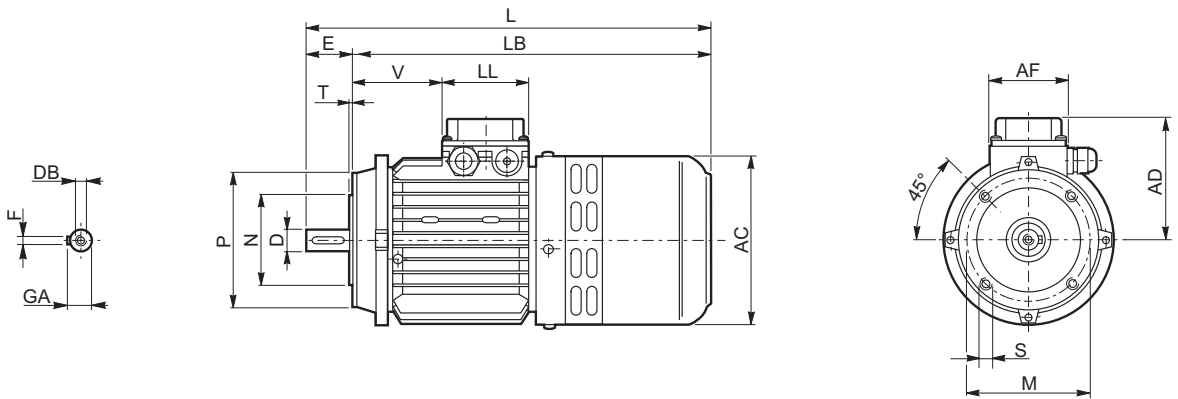

	Albero / Shaft / Welle / Arbre					Flangia / Flange / Flansch / Bride					Motore / Motor / Motor / Moteur						
	D DA	E EA	DB	GA GC	F FA	M	N	P	S	T	AC	L	LB	AD	AF	LL	V
BN 63	11	23	M4	12.5	4	75	60	90	M5	2.5	124	298	275	95	74	80	28
BN 71	14	30	M5	16	5	85	70	105	M6	2.5	138	327	297	108	74	80	68
BN 80	19	40	M6	21.5	6	100	80	120	M6	3	156	372	332	119	74	80	83
BN 90	24	50	M8	27	8	115	95	140	M8	3	176	425	375	133	98	98	95
BN 100	28	60	M10	31	8	130	110	160	M8	3.5	195	477	417	142	98	98	119
BN 112	28	60	M10	31	8	130	110	160	M8	3.5	219	500	440	157	98	98	128
BN 132	38	80	M12	41	10	165	130	200	M10	4	258	638	558	193	118	118	180

N.B.:

Le dimensioni AD, AF, LL e V relative alla scatola morsetti dei motori BN...BA dotati di alimentazione separata del freno (opzione SA) coincidono con quelle dei motori BN...FD di pari taglia.

NOTE:

Dimensions AD, AF, LL and V, relevant to terminal box of motors BN...BA featuring the separate brake supply (option SA), are coincident with corresponding dimensions of same-size BN...FD motors

HINWEIS:

Die Abmessungen des Klemmenkastens der Motoren BN ... BA AD, AF, LL und V in bezug auf die separate Spannungsversorgung (Option SA) stimmen mit den Abmessungen der entsprechenden Motoren BN...FD überein.

REMARQUE :

Les dimensions AD, AF, LL et V relatives à la boîte à borne des moteurs BN...BA équipés d'alimentation séparée du frein (option SA) sont identiques à celles des moteurs BN...FD de la même taille.

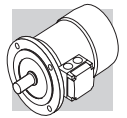

BN_BA

IM B5

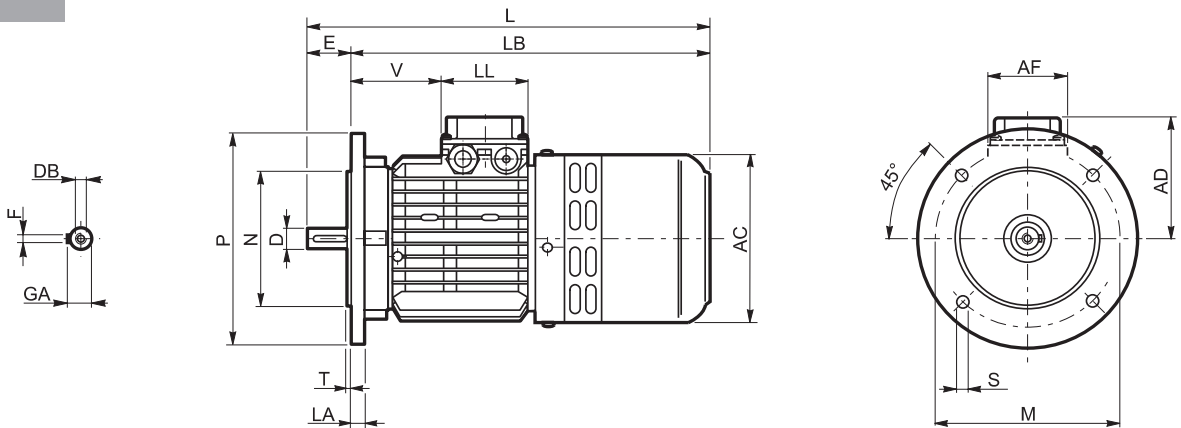

	Albero / Shaft / Welle / Arbte					Flangia / Flange / Flansch / Bride						Motore / Motor / Motor / Moteur						
	D DA	E EA	DB	GA GC	F FA	M	N	P	S	T	LA	AC	L	LB	AD	AF	LL	V
BN63	11	23	M4	12.5	4	115	95	140	9.5	3	10	124	298	275	95	74	80	28
BN 71	14	30	M5	16	5	130	110	160	9.5	3.5	10	138	327	297	108	74	80	68
BN 80	19	40	M6	21.5	6	165	130	200	11.5	3.5	11.5	156	372	332	119	74	80	83
BN 90	24	50	M8	27	8	165	130	200	11.5	3.5	11.5	176	425	375	133	98	98	95
BN 100	28	60	M10	31	8	215	180	250	14	4	14	195	477	417	142	98	98	119
BN 112	28	60	M10	31	8	215	180	250	14	4	15	219	500	440	157	98	98	128
BN 132	38	80	M12	41	10	265	230	300	14	4	16	258	638	558	193	118	118	180

N.B.:

Le dimensioni AD, AF, LL e V relative alla scatola morsetti dei motori BN...BA dotati di alimentazione separata del freno (opzione SA) coincidono con quelle dei motori BN...FD di pari taglia.

NOTE:

Dimensions AD, AF, LL and V, relevant to terminal box of motors BN...BA featuring the separate brake supply (option SA), are coincident with corresponding dimensions of same-size BN...FD motors

HINWEIS:

Die Abmessungen des Klemmkastens der Motoren BN ... BA AD, AF, LL und V in bezug auf die separate Spannungsversorgung (Option SA) stimmen mit den Abmessungen der entsprechenden Motoren BN...FD überein.

REMARQUE :

Les dimensions AD, AF, LL et V relatives à la boîte à borne des moteurs BN...BA équipés d'alimentation séparée du frein (option SA) sont identiques à celles des moteurs BN...FD de la même taille.

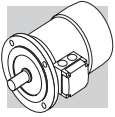

M

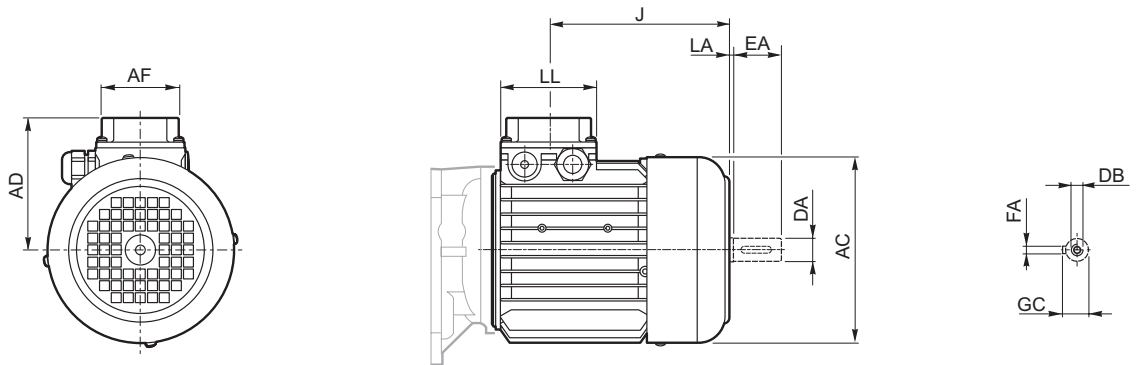

	AC	AD	AF	LL	J	DA	EA	LA	DB	GC	FA
M 0	110	91	74	80	91	9	20	2	M3	10.2	3
M 05	121	95	74	80	117	11	23	3	M4	12.5	4
M 1S	138	108	74	80	118	14	30	2	M5	16	5
M 1L	138	108	74	80	142	14	30	2	M5	16	5
M 2S	156	119	74	80	152	19	40	3	M6	21.5	6
M 3S	195	142	98	98	176.5	28	60	3	M10	31	8
M 3L	195	142	98	98	208.5	28	60	3	M10	31	8
M 4	258	193	118	118	296.5	38	80	3	M12	41	10
M 4LC	258	193	118	118	331.5	38	80	3	M12	41	10
M 5S	310	245	187	187	341.5	38	80	4	M12	41	10
M 5L	310	245	187	187	385	38	80	4	M12	41	10

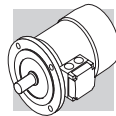

M_FD

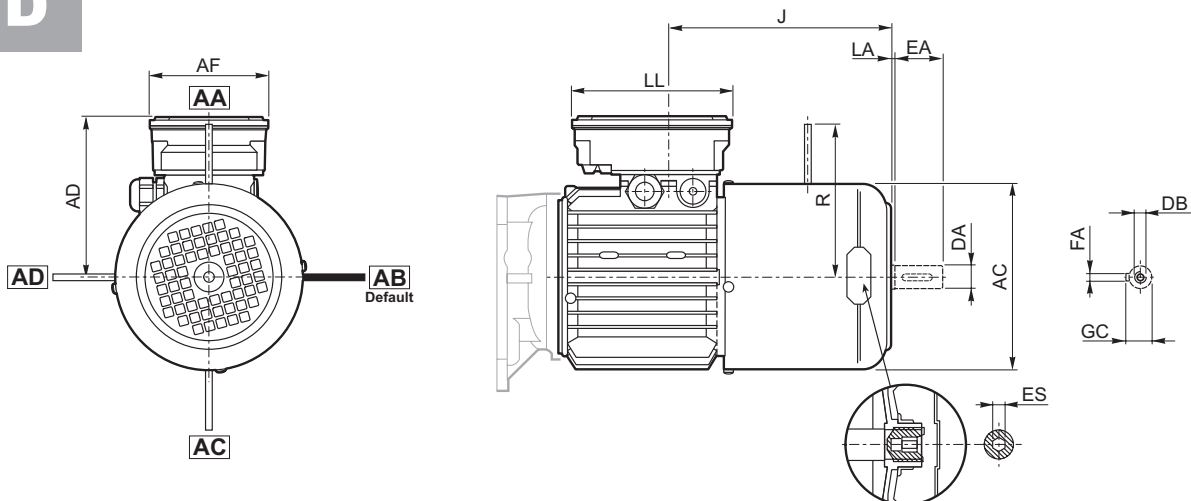

	AC	AD	AF	LL	J	R	DA	EA	LA	DB	GC	FA	ES
M 05	121	119	98	133	183	96	11	23	2	M4	12.5	4	5
M 1S	138	132	98	133	153	103	14	30	2	M5	16	5	5
M 1L	138	132	98	133	175	103	14	30	2	M5	16	5	5
M 2S	156	143	98	133	184	129	19	40	2	M6	21.5	6	5
M 3S	195	155	110	165	202	160	28	60	3	M10	31	8	6
M 3L	195	155	110	165	229	160	28	60	3	M10	31	8	6
M 4	258	193	118	118	285	226	38	80	3	M12	41	10	6
M 4LC	258	193	118	118	431	226	38	80	3	M12	41	10	6
M 5S	310	245	187	187	481	266	38	80	4	M12	41	10	—
M 5L	310	245	187	187	525	266	38	80	4	M12	41	10	—

N.B.:

L'esagono ES non è presente con l'opzione PS.

NOTE:

The hexagonal socket "ES" is not available with the PS option.

HINWEIS:

Der Sechskant ES ist bei der Option PS nicht vorhanden.

REMARQUE :

L'hexagone ES n'est pas disponible avec l'option PS.

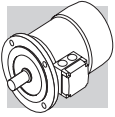

M_FA

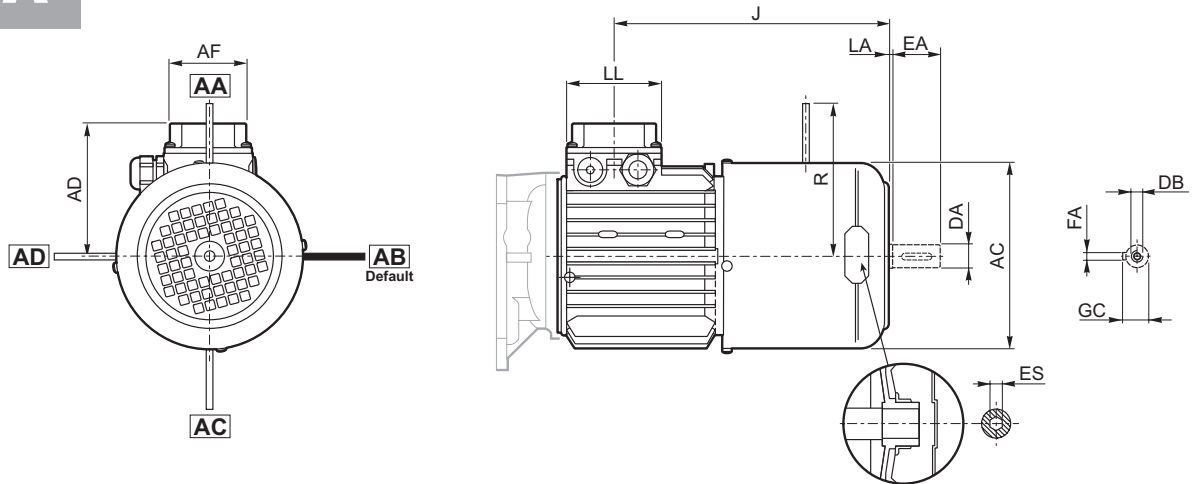

	AC	AD	AF	LL	J	R	DA	EA	LA	DB	GC	FA	ES
M 05	121	95	74	80	183	116	11	23	2	M4	12.5	4	5
M 1S	138	108	74	80	153	124	14	30	2	M5	16	5	5
M 1L	138	108	74	80	175	124	14	30	2	M5	16	5	5
M 2S	156	119	74	80	184	134	19	40	2	M6	21.5	6	5
M 3S	195	142	98	98	202	160	28	60	3	M10	31	8	6
M 3L	195	142	98	98	229	160	28	60	3	M10	31	8	6
M 4	258	193	118	118	285	217	38	80	3	M14	41	10	6
M 4LC	258	193	118	118	431	217	38	80	3	M14	41	10	6
M 5S	310	245	187	187	481	247	38	80	4	M12	41	10	—
M 5L	310	245	187	187	525	247	38	80	4	M12	41	10	—

N.B.:

L'esagone ES non è presente con l'opzione PS.

NOTE:

The hexagonal socket "ES" is not available with the PS option.

HINWEIS:



Der Sechskant ES ist bei der Option PS nicht vorhanden.

REMARQUE :

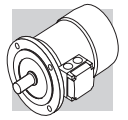
L'hexagone ES n'est pas disponible avec l'option PS.

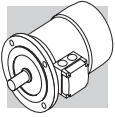



R4				
Descrizione	Description	Beschreibung	Description	
 338	Aggiunta della Certificazione UL alla preesistente CSA - opzione CUS	<i>UL certification adds up to former CSA - option CUS</i>	UL Zertifikat zusätzlich zum bestehenden CSA Zertifikat - Option CUS	<i>Ajout de la certification UL à celle déjà existante (CSA) - Option CUS</i>
 373	Aggiornate dimensioni tettuccio parapioggia - Opzione RC	<i>Dimension revised for rain canopy - option RC</i>	Abmessungen Schutzdach überarbeitet - Option RC	<i>Mise à jour des dimensions des capots de protection anti-pluie - Option RC</i>

Questa pubblicazione annulla e sostituisce ogni precedente edizione o revisione. Ci riserviamo il diritto di apportare modifiche senza preavviso. È vietata la produzione anche parziale senza autorizzazione.

This publication supersedes and replaces any previous edition and revision. We reserve the right to implement modifications without notice. This catalogue cannot be reproduced, even partially, without prior consent.

Diese Veröffentlichung annulliert und ersetzt jeder hergehende Edition oder Revision. BONFIGLIOLI behält sich das Recht vor, Änderungen ohne vorherige Informationen durchzuführen.

Cette publication annule et remplace toutes les autres précédentes. Nous nous réservons le droit d'apporter toutes modifications à nos produits. La reproduction et la publication partielle ou totale de ce catalogue est interdite sans notre autorisation.

300



www.bonfiglioli.com



BONFIGLIOLI