



HIGH PRECISION BALL BEARINGS

Extra Thin Type Bearings
Flanged Bearings
Stainless Bearings
Bore Dia, 0.6mm To 90mm





Technical Contents

- Bearing numbering system 3
- Design and characteristics of radial ball bearings 4
- Bearing material 4
- Type and characteristics of cages, shields and seals 5
- Tolerance, class, chamfer dimension of bearings 6
- Life and load rating 8
- Fitting of bearings 11
- Internal clearance 14
- Lubrication 16
- Maximum permissible bearing speed 19
- Frictional torque and temperature 19
- Basic rules for selecting and handling of bearings 20
- Problem, Cause, Remedy 21
- Damage, Cause, Remedy 22

Bearing numbering system

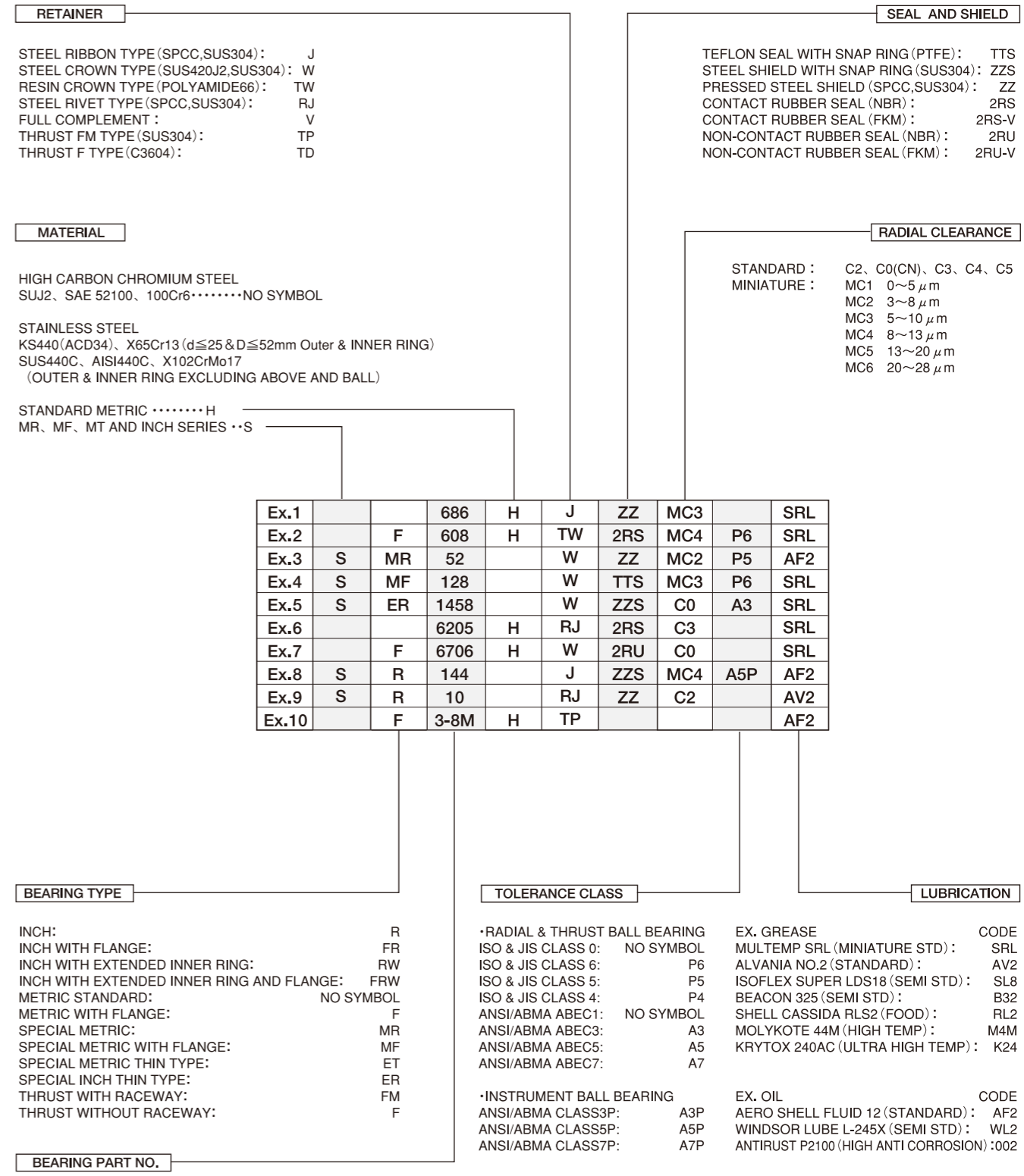

Design and characteristics of radial ball bearings

STRUCTURE OF BEARING

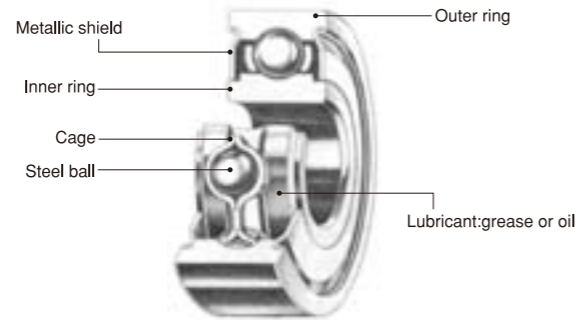

DESIGN OF BEARING

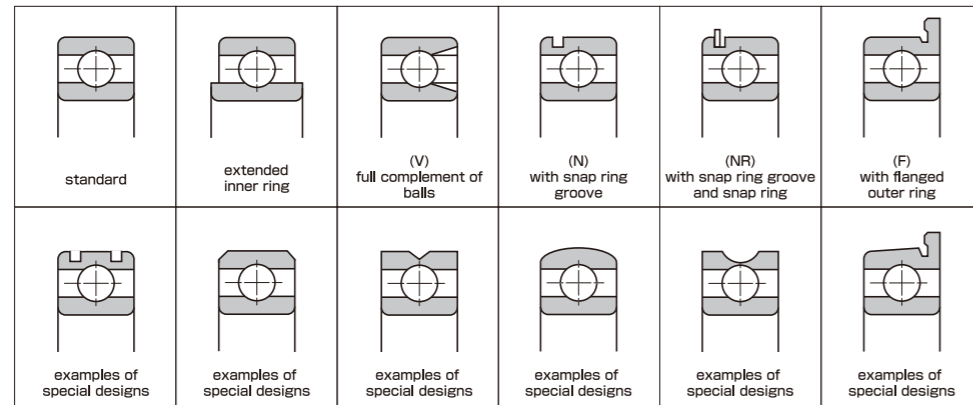

CHARACTERISTICS OF BEARINGS

LOAD	Single row radial ball bearings with balls separated by a cage can support radial loads, axial loads and tilting moments. A full complement V-type ball bearing can support only radial loads and some low axial loads.
SPEED	Maximum permissible speeds for ball bearings are mainly related to the bearing design and size, cage type, bearing internal clearance, method and type of lubrication, manufacturing accuracy, sealing methods and loads.
TORQUE AND NOISE LEVEL	Single row radial ball bearings are precision components and have low torque and noise levels.
INCLINATION OF INNER/OUTER RINGS	Shaft and housing seats with poor accuracy, fitting errors and shaft bending might cause inclination between the inner and outer rings although the internal clearance of the bearing will permit this to a certain extent. Generally, the maximum permissible inclination between the inner and outer rings is approximately 1 in 300.
TOUGHNESS	Bearings under load deform elastically at the contact point between the rolling element and bearing ring. This is influenced by the bearing type, size, form and load.
INSTALLATION AND REMOVAL	The single row radial ball bearing is a non-separable bearing. Therefore, shafts and housings should be so designed to enable bearing inspection and replacement when necessary.
AXIAL LOCATION	Improved axial location is obtained with NR and F type bearings.

Bearing material

Standard material for rings and balls is a vacuum degassed high carbon chromium steel allowing for high efficiency, low torque, low noise level and long bearing life. For bearings requiring anti-corrosion or heat-resistance properties, martensitic stainless steel is used.

CHEMICAL COMPOSITION OF BEARING MATERIALS

MATERIAL	SYMBOL	CHEMICAL COMPOSITION (Wt%)							EQUIVALENT	HARDNESS (HRC)
		C	Si	Mn	P	S	Cr	Mo		
HIGH CARBON CHROMIUM STEEL	SUJ2	0.95~1.10	0.15~0.35	≤0.50	≤0.025	≤0.025	1.30~1.60	≤0.08	SAE52100, 100Cr6, ASTM52100, BS535A99, 1.3505	60~64
STAINLESS STEEL	SUS440C	0.95~1.20	≤1.00	≤1.00	≤0.040	≤0.030	16.0~18.0	≤0.75	AISI440C, X102CrMo17, X105CrMo17, 1.4125, 1.3543	58~62
	KS440 (ACD34)	0.60~0.75	≤1.00	≤1.00	≤0.030	≤0.020	11.5~13.0	≤0.30	X65Cr13, 1.4037	58~62

Type and characteristics of cages, shields and seals

CAGES

W : ONE-PIECE STEEL CROWN TYPE	J : TWO-PIECES STEEL RIBBON TYPE	RJ : TWO-PIECES STEEL RIVET TYPE	TW : ONE-PIECE NYLON CROWN TYPE	V : FULL COMPLEMENT OF BALLS
The stainless steel pressed cage is inner ring guided. It shows excellent performance in low torque, low speed applications.	Consists of two mating steel pressings, the cover side and the finger side. Usually guided by the rolling elements and designed to reduce frictional torque.	The RJ type cage is suitable for larger bearings with a high load carrying capacity. The two pieces are riveted together and are strong enough to withstand higher levels of vibration and acceleration. The cage is guided by the balls and reduces frictional torque.	Moulded nylon cage. Reduces the fluctuation in running torque. Suitable for high speeds. Guided by the rolling elements. NYLON CAGE operating temperature range: from -30 to +120°C	This type of bearing has no cage but maximum possible number of balls. Due to the fact that the inner and outer ring have a filling slot, the axial load carrying capacity of this bearing type is low. This type of bearing is suitable for high radial load, low speed applications.

SHIELD , SEAL

ZZ : PRESSED STEEL SHIELD	ZZS : STEEL SHIELD WITH SNAP RING	TTS : TEFLON SEAL WITH SNAP RING	2RS : CONTACT RUBBER SEAL	2RU : NON-CONTACT RUBBER SEAL
Non-contact shield pressed into outer ring. Very little grease leakage and low ingress of contaminants.	Non-contact shield retained in outer ring. Low ingress of contaminants. Mainly used for smaller or narrower bearings.	Teflon seal reinforced with glass fibre is retained in outer ring by snap ring. Low ingress of contaminants. Mainly used for smaller or narrower bearings. Seal can flex to accommodate internal pressure changes. TEFLON SEAL operating temperature range: from -100 to +260°C	Rubber seal fitted into outer ring. Light contact with inner ring, retains grease and prevents ingress of external contaminants. NBR SEAL operating temperature range: from -40 to +120°C FKM(VITON)SEAL operating temperature range: from -30 to +230°C	Non-contact rubber seal fitted into outer ring, still provides effective sealing. NBR SEAL operating temperature range: from -40 to +120°C FKM(VITON)SEAL operating temperature range: from -50 to +230°C

Technical Dimension

Tolerance, class, chamfer dimension of bearings

TOLERANCES OF INNER RING AND OUTER RING WIDTH (ISO)

d (mm)		Δ_{dmp}				Δ_{ds}		V_{dp}								V_{dmp}						
		P0	P6	P5	P4	P4		P0		P6		P5		P4		P0	P6	P5	P4			
						Diameter series		Diameter series		Diameter series		Diameter series		Diameter series								
		0,2,3		7,8,9		0,2,3		7,8,9		0,2,3		7,8,9		0,2,3		7,8,9		0,2,3				
Over	Incl.	Upper	Lower	Lower	Lower	Upper	Lower	Max.		Max.		Max.		Max.		Max.	Max.	Max.	Max.			
0.6(1)	2.5	0	-8	-7	-5	-4	0	-4	10	8	6	9	7	5	5	4	4	3	6	5	3	2
2.5	10	0	-8	-7	-5	-4	0	-4	10	8	6	9	7	5	5	4	4	3	6	5	3	2
10	18	0	-8	-7	-5	-4	0	-4	10	8	6	9	7	5	5	4	4	3	6	5	3	2
18	30	0	-10	-8	-6	-5	0	-5	13	10	8	10	8	6	5	5	4	4	8	6	3	2.5
30	50	0	-12	-10	-8	-6	0	-6	15	12	9	13	10	8	6	6	5	5	9	8	4	3

Remarks1: The upper value of the bore diameter in this table is not applicable when the distance from the bearing ring face is less than 1.2 times the chamfer dimension r_{smax}
 Remarks2: According to the revision of ANSI/ABMA Std.20-1996, the classes ABEC1 · ABEC3 · ABEC5 · ABEC7 are equivalent to CLASS0 · CLASS6 · CLASS5 · CLASS4.

TOLERANCES OF OUTER RING (ISO)

D (mm)		Δ_{Dmp}				Δ_{Ds}		$V_{Dp}^{(2)}$								$V_{Dmp}^{(2)}$								
		P0	P6	P5	P4	P4		P0		P6		P5		P4		P0	P6	P5	P4					
						Open		Seal Shield		Open		Seal Shield		Open						Open				
		Diameter series		Diameter series		Diameter series		Diameter series		Diameter series		Diameter series		Diameter series										
0,2,3		7,8,9		0,2,3		7,8,9		0,2,3		7,8,9		0,2,3		7,8,9		0,2,3								
Over	Incl.	Upper	Lower	Lower	Lower	Upper	Lower	Max.		Max.		Max.		Max.		Max.	Max.	Max.	Max.					
2.5(1)	6	0	-8	-7	-5	-4	0	-4	10	8	6	10	9	7	5	9	5	4	4	3	6	5	3	2
6	18	0	-8	-7	-5	-4	0	-4	10	8	6	10	9	7	5	9	5	4	4	3	6	5	3	2
18	30	0	-9	-8	-6	-5	0	-5	12	9	7	12	10	8	6	10	6	5	5	4	7	6	3	2.5
30	50	0	-11	-9	-7	-6	0	-6	14	11	8	16	11	9	7	13	7	5	6	5	8	7	4	3
50	80	0	-13	-11	-9	-7	0	-7	16	13	10	20	14	11	8	16	9	7	7	5	10	8	5	3.5

Remarks1: The lower value of the outside diameter in this table is not applicable when the distance from the bearing ring face is less than 1.2 times the chamfer dimension r_{smax}
 Remarks2: According to the revision of ANSI/ABMA Std.20-1996, the classes ABEC1 · ABEC3 · ABEC5 · ABEC7 are equivalent to CLASS0 · CLASS6 · CLASS5 · CLASS4.

TOLERANCES OF INNER RING AND OUTER RING WIDTH (ABMA)

d (mm)		Δ_{dmp}		Δ_{ds}		V_{dp}		V_{dmp}		$\Delta_{Bs}(\Delta_{Cs})$		V_{Bs}		K_{ia}		S_{ia}		S_{dl}	
		ABEC 5P ABEC 7P		ABEC 5P ABEC 7P		ABEC 5P ABEC 7P		ABEC 5P ABEC 7P		Single bearing ABEC 5P ABEC 7P		ABEC 5P	ABEC 7P	ABEC 5P	ABEC 7P	ABEC 5P	ABEC 7P	ABEC 5P	ABEC 7P
		Over	Incl.	Upper	Lower	Upper	Lower	Max.	Max.	Upper	Lower	Max.	Max.	Max.	Max.	Max.	Max.	Max.	Max.
-	10	0	-5	0	-5	2.5	2.5	0	-25	5	2.5	3.5	2.5	7	3	7	3		
10	18	0	-5	0	-5	2.5	2.5	0	-25	5	2.5	3.5	2.5	7	3	7	3		
18	30	0	-5	0	-5	2.5	2.5	0	-25	5	2.5	3.5	2.5	7	3	7	3		

Remarks1: ABEC5P and ABEC7P are the tolerance classes for high precision bearings.

LIMIT TOLERANCE VALUES (METRIC) OF CHAMFER DIMENSIONS OF RADIAL BEARINGS

r_{smin}	d(mm)		r_{smax}		r_{amax}
	Over	Incl.	Radial	Axial	
0.05	-	-	0.10	0.20	0.05
0.08	-	-	0.16	0.30	0.08
0.10	-	-	0.20	0.40	0.10
0.15	-	-	0.30	0.60	0.15
0.20	-	-	0.50	0.80	0.20
0.30	-	40	0.60	1.00	0.30
0.30	40	-	0.80	1.00	0.30
0.60	-	40	1.00	2.00	0.60
0.60	40	-	1.30	2.00	0.60
1.00	-	50	1.50	3.00	1.00
1.00	50	-	1.90	3.00	1.00
1.10	-	120	2.00	3.50	1.00
1.10	120	-	2.50	4.00	1.00
1.50	-	120	2.30	4.00	1.50
1.50	120	-	3.00	5.00	1.50

- d : Nominal bore diameter
- Δ_{dmp} : Single plane mean bore diameter deviation
- Δ_{ds} : Deviation of a single bore diameter
- V_{dp} : Bore diameter variation in a single radial plane
- V_{dmp} : Mean bore diameter variation
- $\Delta_{Bs}(\Delta_{Cs})$: Deviation of the single inner and outer ring width from the nominal dimension
- $V_{Bs}(V_{Cs})$: Variation Of the inner and outer ring width
- K_{ia} : Radial runout of assembled bearing inner ring
- S_{dl} : Face runout with bore
- S_{ia} : Assembled bearing inner ring face runout with raceway
- D : Nominal outside diameter
- Δ_{Dmp} : Single plane mean outside diameter deviation
- Δ_{Ds} : Deviation of a single outside diameter
- V_{Dp} : Outside diameter variation in a single radial plane
- V_{Dmp} : Mean outside diameter variation
- K_{ea} : Radial runout of assembled bearing outer ring
- S_{dl} : Variation of outside surface generatrix inclination with face
- S_{ea} : Assembled bearing outer ring face runout with raceway
- V_{Cs} : Variation of the outer ring width
- Δ_{Dis} : Flange outside diameter deviation
- Δ_{Cis} : Flange width deviation
- r_{smin} : Smallest permissible single chamfer dimension (minimum limit)
- d : Nominal bore diameter
- r_{smax} : Largest permissible single chamfer dimension (maximum limit)
- r_{amax} : Largest permissible single shaft and housing fillet radius

Note(1) : The value of r_{amax} in axial direction of bearing with nominal width of under 2mm is the same as the one in radial direction

d (mm)		$\Delta_{Bs}(\Delta_{Cs})^{(2)}$				$V_{Bs}(V_{Cs})^{(2)}$				K_{ia}				S_{dl}		S_{ia}	
		Single bearing		Inner/outer ring		Inne ring		P0	P6	P5	P4	P5	P4	P5	P4		
		P0 P6	P5 P4	P0	P6	P5	P4										
		Upper	Lower	Lower	Max.	Max.	Max.	Max.	Max.	Max.	Max.	Max.	Max.	Max.	Max.	Max.	Max.
0	-40	-40	12	12	5	2.5	10	5	4	2.5	7	3	7	3	0.6(1)	2.5	
0	-120	-40	15	15	5	2.5	10	6	4	2.5	7	3	7	3	2.5	10	
0	-120	-80	20	20	5	2.5	10	7	4	2.5	7	3	7	3	10	18	
0	-120	-120	20	20	5	2.5	13	8	4	3	8	4	8	4	18	30	
0	-120	-120	20	20	5	2.5	15	10	5	4	8	4	8	4	30	50	

Note (1) : 0.6mm is included in this classification.

Note (2) : The inner ring width variation is the same for the outer ring of the same bearing size. CLASS5 and CLASS4 referring to outer ring only.

D (mm)		K_{ea}				S_{Dl}		S_{ea}		$V_{Cs}^{(2)}$		D (mm)		Flanged type				Flanged type			
		P0	P6	P5	P4	P5	P4	P5	P4	P5	P4			Δ_{Dis}		d (mm)		Δ_{Cis}			
												P0	P6	P5	P4			P0	P6	P5	P4
		Max.	Max.	Max.	Max.	Max.	Max.	Max.	Max.	Max.	Max.	Max.	Over	Incl.	Upper	Lower	Upper	Lower	Upper	Lower	Upper
15	8	5	3	8	4	8	5	5	2.5	-	10	+220	-36	0	-36	0.6	2.5	0	-40	0	-40
15	8	5	3	8	4	8	5	5	2.5	10	18	+270	-43	0	-43	2.5	10	0	-120	0	-40
15	9	6	4	8	4	8	5	5	2.5	18	30	+330	-52	0	-52	10	18	0	-120	0	-80
20	10	7	5	8	4	8	5	5	2.5	30	50	+390	-62	0	-62	18	30	0	-120	0	-120
25	13	8	5	8	4	10	5	6	3	50	80	+460	-74	0	-74	30	50	0	-120	0	-120

Note (1) : Size 2.5mm is included in this classification.

Note (2) : Applicable without locating snap ring.

Note (3) : The outer ring width variations for CLASS0 and CLASS6 are the same as for the inner ring of the same bearing size.

TOLERANCES OF OUTER RING (ABMA)

D (mm)		Δ_{Dmp}				Δ_{Ds}				V_{Dp}, V_{Dmp}		$\Delta_{Bs}(\Delta_{Cs})$		$V_{Cs}^{(1)}$		S_{Dl}		K_{ea}		S_{ea}		Flanged type						
		Open		Seal,Shield		ABEC 5P,7P		Single bearing		ABEC 5P	ABEC 7P	ABEC 5P	ABEC 7P	ABEC 5P	ABEC 7P	ABEC 5P	ABEC 7P	ABEC 5P	ABEC 7P	ABEC 5P	ABEC 7P	ABEC 5P	ABEC 7P	ABEC 5P	ABEC 7P			
		Over	Incl.	Upper	Lower	Lower	Upper	Lower	Lower	Upper	Lower	Max.	Max.	Upper	Lower	Max.	Max.	Max.	Max.	Max.	Max.	Max.	Max.	Max.	Max.	Max.		
-	18	0	-5	-5	0	-5	-5	+1	-6	-6	2.5	5	0	-25	5	2.5	8	4	5	3.5	8	5	0	-25	0	-51	7.5	5
18	30	0	-6	-5	0	-6	-5	+1	-7	-6	2.5	5	0	-25	5	2.5	8	4	6	4	8	5	0	-25	0	-51	7.5	5
30	50	0	-6	-5	0	-6	-5	+1	-7	-6	2.5	5	0	-25	5	2.5	8	4	6	4	8	5	0	-25	0	-51	7.5	5

Note (1) : Applies to flange width variation of flanged bearing.

Note (2) : Applies to flange back face.

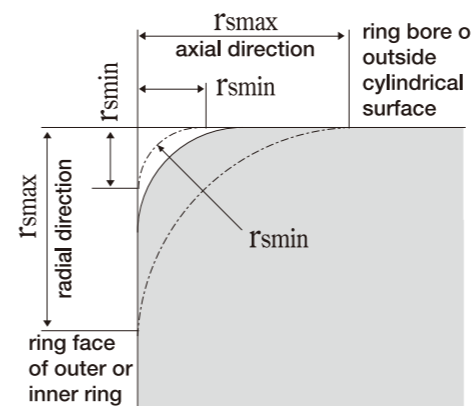

r_{smin} = smallest permissible single chamfer dimension (minimum limit)
 r_{smax} = largest permissible single chamfer dimension (maximum limit)
 r_{amax} = largest permissible single shaft and housing fillet radius

NOTE: The exact shape of the chamfer surface is not specified, but its contour in an axial plane shall not be allowed to project beyond the imaginary circular arc, of radius r_{smin} , tangential to the ring face and the bore or outside cylindrical surface of the ring (see figure).

Technical Dimension

Life and load rating

BEARING LIFE

When bearings rotate, the inner and outer rings and rolling elements are constantly loaded. This produces material fatigue and eventually bearing failure. The total number of revolutions before a failure occurs is called the basic rating life.

Life of individual bearings varies considerably, even if they are of the same size, same material, same heat treatment and are under the same operating conditions.

Statistically, the total number of revolutions reached or exceeded by 90% of a sufficiently large group of apparently identical bearings before the first evidence of material fatigue occurs is called the basic rating life.

BASIC DYNAMIC LOAD RATING "Cr"

The basic dynamic load rating of a bearing with rotating inner ring and stationary outer ring is that load of constant magnitude and size which a sufficiently large group of apparently identical bearings can endure for a basic rating life of one million revolutions.

Radial bearings take central load. Values given for Cr in the dimension tables of this catalogue are for standard high chromium steel. 85% of the chromium steel values should be used for stainless steel.

LIFE FORMULA

The equation for the basic rating life for dynamically loaded ball bearings is as follows:

$$L_{10} = (Cr/P)^3 \times 10^6 \text{ (Revolutions)}, L_{10h} = 16667/n \cdot (Cr/P)^3 \text{ (Hours)}$$

whereby:
 L_{10} = BASIC RATING LIFE
 Cr = BASIC DYNAMIC LOAD RATING(N)
 n = R.P.M. (REVOLUTIONS PER MINUTE)
 L_{10h} = BASIC RATING LIFE IN OPERATING HOURS
 P = EQUIVALENT LOAD(N)

EXAMPLES OF RATING LIFE L_{10h} VALUES USED:

OPERATING CONDITIONS	BASIC RATING LIFE L_{10h}
Infrequent operation.	500
Short or intermittent operation. Failure has little effect on function.	4,000~8,000
Intermittent operation. Failure has significant effect on function.	8,000~12,000
8 hours of non-continuous operation.	12,000~20,000
8 hours of continuous operation.	20,000~30,000
24 hours continuous operation.	40,000~60,000
24 hours of guaranteed trouble-free operation.	100,000~200,000

ADJUSTED LIFE FORMULA

The above life formula is for general use. In cases where a reliability of over 90% is required and where influences apart from load and speed or operating frequency should be taken into account for the rating life, ISO 281, 1990 gives an extended life formula:

$$L_n = a_1 \times a_2 \times a_3 \times (Cr/P)^3 \times 10^6 \text{ (Revolutions)}$$

whereby:
 L_n = Adjusted rating life in millions with a reliability of (100-n)% (n=the reliability rate)
 Cr = BASIC DYNAMIC LOAD RATING(N)
 P = EQUIVALENT DYNAMIC LOAD(N)
 a_1 = Factor for a reliability other than 90%
 a_2 = Factor for non-conventional materials
 a_3 = Factor for non-conventional operating conditions, in particular lubrication

(1) RELIABILITY FACTOR a_1

When a reliability of over 90% is required, the corresponding factor should be selected from the following table.

● RELIABILITY FACTOR a_1

Reliability	90	91	92	93	94	95	96	97	98	99	(99.6)	(99.9)
a_1	1.00	0.92	0.84	0.77	0.64	0.62	0.53	0.44	0.33	0.21	(0.10)	(0.037)

(2) MATERIAL FACTOR a_2

Improvement in manufacturing techniques for raw material and for heat treatment of components have led to an extended fatigue life for bearings.

Our standard bearing material is a superior quality of vacuum degassed steel leading to an extended life for bearings.

The basic load ratings given in this catalogue have been established by taking this longer life into consideration. This gives an increase in the operating life in hours of a factor of 2.2 and a factor of 1.3 for the load carrying capacity. The material factor $a_2=1$.

(3) OPERATING CONDITIONS FACTOR a_3

This is an adjustment factor to meet non-conventional operating conditions for lubrication, temperature and load. Under good lubrication conditions with a permanent oil film between rolling elements and rings, the factor $a_3=1$. In unfavourable conditions ($d_m \cdot n \leq 10,000$), a factor $a_3 < 1$ must be selected. d_m = mean bearing diameter = $(D+d)/2$, n = operating speed.

At temperatures above 120°C, greater dimensional changes occur and the material hardness deteriorates which affects the bearing life.

The operating factor f_t for temperature can be taken from the following table:

● OPERATING TEMPERATURE AND LIFE COMPENSATION FACTOR f_t

BEARING TEMPERATURE (°C)	120	150	175	200	225	250	275	300
TEMPERATURE FACTOR (f_t)	1.00	0.90	0.85	0.75	0.65	0.60	0.52	0.45

Heat stabilized bearings, where the dimensions are stable above 120°C, are available on request.

BASIC STATIC LOAD RATING "Cor"

The Basic Static Load Rating applies to bearings where rotating motion does not occur or occurs only infrequently. The Basic Load Ratings and calculation methods in this catalogue are based on methods described in ISO 281 and on ISO Recommendations NR.76, taking into account the current level of bearing technology.

Excessive static load causes brinelling at the contact point between the rolling element and raceway.

As a standard of permissible static load, the basic load rating Cor for radial bearings is specified as follows:

Maximum contact pressure at the contact point between rolling element and bearing ring to be 4200 MPa and total permanent deformation of the bearing of appr. 1/10000th of the rolling element's diameter.

Basic Static Load Rating for stainless steel is 80% of that for standard bearing steel.

EQUIVALENT DYNAMIC BEARING LOAD "P"

Load conditions on bearings are usually a combination of radial and axial loads. In order to establish the equivalent radial load with definite force and direction we use the following formula:

● RADIAL LOAD FACTOR AND AXIAL LOAD FACTOR

Fa/(ZD ²)	e	Fa/Fr ≤ e		Fa/Fr > e	
		X	Y	X	Y
0.172	0.19	1	0	0.56	2.30
0.345	0.22	1	0	0.56	1.99
0.689	0.26	1	0	0.56	1.71
1.03	0.28	1	0	0.56	1.55
1.38	0.30	1	0	0.56	1.45
2.07	0.34	1	0	0.56	1.31
3.45	0.38	1	0	0.56	1.15
5.17	0.42	1	0	0.56	1.04
6.89	0.44	1	0	0.56	1.00

$$P = XFr + YFa(N)$$

X=RADIAL LOAD FACTOR
Y=AXIAL LOAD FACTOR
D=BALL DIAMETER(mm)

EQUIVALENT STATIC RADIAL LOAD "Po"

For ball bearings subject to both radial and axial loads, the static radial load with definite force and direction is called the Equivalent Static Radial Load.

The higher value from the two formula shown below should be used.

$$Po = 0.6 \times Fr + 0.5 \times Fa(N), Po = Fr(N)$$

SAFETY MODULUS "fs"

Permissible equivalent static load depends on basic static load rating. But using limit of bearing charge by using condition. Accordingly we use safety modulus which is experimental value.

fs = Cor / Po
fs=SAFETY MODULUS
Cor=BASIC STATIC LOAD RATING(N)
Po=EQUIVALENT STATIC RADIAL LOAD(N)

USING CONDITION	fs
NORMAL OPERATION	1.0
SHOCK LOAD	1.5
SILENT AND HIGH ACCURATE ROTATION	2.0

Fitting of bearings

THE IMPORTANCE OF CORRECT FITTING

A bearing can only perform to its full capacity when it is correctly fitted on the shaft and in the housing. Insufficient interference on fitting surfaces could cause bearing rings to creep in a circumferential direction. Once this happens, considerable wear occurs on the fitting surface and both shaft and housing are damaged. Furthermore, abrasive particles may enter the bearing causing vibration, excessive heat and damage to raceways. It is therefore necessary to provide bearing rings under rotating load with an adequate interference fit to prevent creep. When using thin-type bearings under low load, the bearings should be fastened by a nut. Statically loaded bearings generally do not need to be fitted with an interference fit. Only when subject to a high degree of vibration do both inner and outer rings require fitting with an interference fit.

● FITTING OF BEARING AND SHAFT

CONDITION (STEEL SHAFT)	SHAFT BORE DIAMETER	SHAFT TOLERANCE CLASS		
		THIN TYPE	OTHERS	
INNER RING ROTATING LOAD OR INDETERMINATE LOAD DIRECTION	LIGHT LOAD ≤ 0.06Cr OR FLUCTUATING LOAD	10 ≤ d ≤ 18 18 ≤ d ≤ 30 30 ≤ d ≤ 50	h5 h5 h5	js5 js5 js5
	STANDARD LOAD = 0.06 ~ 0.12Cr	10 ≤ d ≤ 18 18 ≤ d ≤ 30 30 ≤ d ≤ 50	js5 js5 js5	j5 k5 k5
OUTER RING ROTATING LOAD	NECESSARY FOR INNER RING TURNING EASILY AROUND SHAFT	ALL BORE DIAMETERS	g5	g6
	UNNECESSARY FOR INNER RING TURNING EASILY AROUND SHAFT	ALL BORE DIAMETERS	h5	h6

● FITTING OF BEARING AND HOUSING

CONDITION (ONE-PIECE HOUSING)	AXIAL DIRECTIONAL MOVEMENT OF OUTER RING	TOLERANCE CLASS OF SHAFT HOUSING SEATS		
		THIN TYPE	OTHERS	
INNER RING ROTATING LOAD	VARYING LOADS	EASY TO MOVE	H6	H7
	LIGHT OR STANDARD LOAD	EASY TO MOVE	H7	H8
	HIGH TEMPERATURE OF INNER RING AND SHAFT	EASY TO MOVE	G6	G7
	LIGHT OR STANDARD LOAD PRECISE ROTATION	AS A RULE, IMPOSSIBLE TO MOVE	K5	K6
		POSSIBLE TO MOVE	JS6	J6
QUIET OPERATION	EASY TO MOVE	H6	H6	
INDETERMINATE LOAD DIRECTION	LIGHT OR STANDARD LOAD	IN GENERAL, POSSIBLE TO MOVE	JS6	J7
	STANDARD OR HEAVY LOAD	AS A RULE, IMPOSSIBLE TO MOVE	K5	K7
	LARGE SHOCK LOAD	IMPOSSIBLE TO MOVE	M5	M7
	LIGHT OR FLUCTUATING LOAD	IMPOSSIBLE TO MOVE	M5	M7
OUTER RING ROTATING LOAD	STANDARD OR HEAVY LOAD	IMPOSSIBLE TO MOVE	N5	N7
	THIN-TYPE HOUSING SEATS HEAVY LOAD OR LARGE SHOCK LOAD	IMPOSSIBLE TO MOVE	P6	P7

●CHARACTERISTICS OF LOAD AND FITTING

ROTATING RING	LOAD	LOAD CONDITION	FITTING
INNER RING	STATIC	INNER RING ROTATING LOAD	INTERFERENCE FIT FOR INNER RING
OUTER RING	ROTATING	OUTER RING STATIC LOAD	CLEARANCE FIT FOR OUTER RING
OUTER RING	STATIC	OUTER RING ROTATING LOAD	CLEARANCE FIT FOR INNER RING
INNER RING	ROTATING	INNER RING STATIC LOAD	INTERFERENCE FIT FOR OUTER RING
IN THE CASE OF FLUCTUATING LOAD DIRECTION OR UNBALANCED LOAD	ROTATING OR STATIC	INDETERMINATE LOAD DIRECTION	INTERFERENCE FIT FOR INNER AND OUTER RING

CALCULATIONS OF FITS

(1) FITTING PRESSURE AND DIMENSIONAL CHANGES OF INNER AND OUTER RING

The right fit for each application is established taking various conditions into consideration such as load, speed, temperature, mounting dismounting of the bearing. The interference fit should be greater than normal in thin housings, housings of soft material or on hollow shafts.

(2) LOAD OF INTERFERENCE

The interference fit of shaft and inner ring decreases under radial load. The decrease in fit of shaft and inner ring is calculated by the following formula:

The higher value from the two formula shown below should be used.

$$\Delta dF = 0.08 \times \sqrt{d/B} \cdot Fr \times 10^{-3} \text{ (mm)}$$

$$\Delta dF = 0.02 \times Fr/B \times 10^{-3} \text{ (mm)}$$

(3) INFLUENCE OF TEMPERATURE ON BEARINGS, SHAFTS AND HOUSINGS

Each inner ring, outer ring or rolling element of a bearing rotating under load generates heat which will affect the interference fits of the shaft and the housing. Assuming a temperature difference within the bearing and the housing of ΔT (C), that of the mating surface of the shaft and of the bearing is $(0.10 \sim 0.15)\Delta T$.

Consequently, ΔdT , the decrease of the inner ring interference fit due to temperature change, is calculated from the following formula:

$$\Delta dT = (0.10 \sim 0.15) \times \Delta T \cdot a \cdot d \approx 0.0015 \times \Delta T \cdot d \times 10^{-3} \text{ (mm)}$$

ΔdT : DECREASE OF INTERFERENCE DUE TO TEMPERATURE DIFFERENCE(mm)

ΔT : TEMPERATURE DIFFERENCE BETWEEN BEARING AND SURROUNDING HOUSING(C)

a : COEFFICIENT OF THERMAL EXPANSION FOR BEARING STEEL $\approx 12.5 \times 10^{-6} (1/C)$
COEFFICIENT OF THERMAL EXPANSION FOR STAINLESS STEEL $\approx 10.3 \times 10^{-6} (1/C)$

d : NOMINAL BORE DIAMETER OF BEARING(mm)

It should also be noted that fit can increase due to temperature changes.

(4) EFFECTIVE INTERFERENCE, SURFACE ROUGHNESS AND ACCURACY

The surface roughness is smoothed during fitting and the effective interference becomes smaller than the theoretical interference. The surface roughness quality of a mating surface has an influence on how much this theoretical interference decreases. Effective interference can usually be calculated as follows:

$$\Delta da = \Delta d - d/(d+2) \cdot \Delta da \text{ (mm)}$$

$$\Delta d = d/(d+3) \cdot \Delta da \text{ (mm)}$$

Δd : EFFECTIVE INTERFERENCE(mm)
 Δda : THEORETICAL INTERFERENCE(mm)
 d : NOMINAL BORE DIAMETER OF BEARING(mm)

By combining these factors, the theoretical interference fit required for inner ring and shaft where the inner ring is subjected to rotating load is calculated as follows:

$$\Delta da \geq (\Delta dF + \Delta dT) \cdot ((d+3)/d \text{ or } (d+2)/d) \text{ (mm)}$$

Normally, shaft and housing seats have to meet the accuracy and roughness requirements as given below.

●ACCURACY AND ROUGHNESS OF SHAFT AND HOUSING SEATS

	SHAFT	HOUSING
ROUNDNESS	BELOW 50% OF SHAFT DIAMETER TOLERANCE	BELOW 50% OF HOUSING BORE DIAMETER TOLERANCE
CYLINDRICITY	BELOW 50% OF SHAFT DIAMETER TOLERANCE WITHIN BEARING WIDTH	BELOW 50% OF HOUSING BORE DIAMETER TOLERANCE WITHIN BEARING WIDTH
SQUARENESS	$\leq 3/1000 (0.17^\circ)$	
ROUGHNESS OF MATING SURFACE	Rmax 3.2	Rmax 6.3

Mounting bearings with extra tight or light interference fits can lead to early bearing failure. In order to ensure safe operating conditions the tolerance variations of shaft seats, housing bores and bearing bore and outside diameter need to be reduced.

We recommend the tolerance zones are divided into two bands and selective assembly is applied. Bearings sorted into two tolerance bands for inner and outer rings are available on request. These bearings are marked as follows:

●SELECTIVE CLASSIFICATION OF OUTER AND BORE DIAMETER TOLERANCES AND INDICATION MARK

TOLERANCES OF OUTER DIAMETER	TOLERANCE OF BORE DIAMETER MARK	0~-D/2	-D/2~-D	0~-D
		1	2	0
0~-d/2	1	C11	C12	C10
-d/2~-d	2	C21	C22	C20
0~-d	0	C01	C02	

NOTE: 1. THIS IS APPLIED TO BOTH BEARINGS OF ABEC 5P AND P5.
2. UPON YOUR REQUEST, PLEASE SPECIFY THE MARK LISTED BELOW.
ZC1... 2 SELECTIVE CLASSIFICATIONS FOR BORE DIAMETER TOLERANCE (0~-d/2, -d/2~-d)
1 SELECTIVE CLASSIFICATION FOR OUTER DIAMETER TOLERANCE (0~-D)
ZC2... 1 SELECTIVE CLASSIFICATION FOR BORE DIAMETER TOLERANCE (0~-d)
2 SELECTIVE CLASSIFICATIONS FOR OUTER DIAMETER TOLERANCE (0~-D/2, -D/2~-D)
ZC3... 4 SELECTIVE CLASSIFICATIONS FOR BOTH BORE AND OUTER DIAMETER TOLERANCE (0~-d/2, -d/2~-d, 0~-D/2, -D/2~-D)
D... MINIMUM VALUE OF OUTER DIAMETER TOLERANCE
d... MINIMUM VALUE OF BORE DIAMETER TOLERANCE

Internal clearance

INTERNAL CLEARANCE AND STANDARD VALUES

Internal clearance is the play between outer ring, inner ring and rolling element. Generally, the amount of up and down movement of the outer ring with respect to the fixed inner ring is called the radial internal clearance and its right and left movement the axial internal clearance. Bearing internal clearance in operation is an important factor that has a significant influence on other factors such as noise, vibration, heat and fatigue life. Radial ball bearings are usually classified by their internal radial clearance. When measuring the internal clearance, the bearing is subjected to a standard load in order to ensure full contact between all bearing components. Under such a load, the measured value is larger than the actual value stated for radial clearance; this is due to elastic deformation. The difference is compensated by the factors given in the tables below.

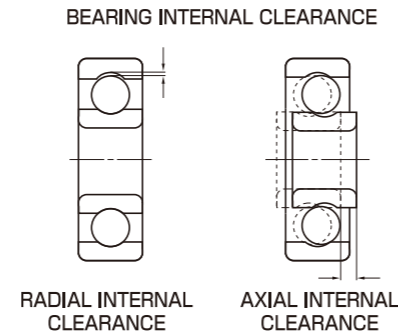

●RADIAL INTERNAL CLEARANCE OF SMALL AND MINIATURE BEARINGS

CLEARANCE SYMBOL	Unit μm						
	MC1	MC2	MC3	MC4	MC5	MC6	
CLEARANCE	min	0	3	5	8	13	20
	max	5	8	10	13	20	28

NOTE: 1. STANDARD CLEARANCE IS MC3.
2. FOR MEASURING CLEARANCE, OFFSET BY COMPENSATION FACTOR LISTED BELOW.

CLEARANCE SYMBOL	Unit μm					
	MC1	MC2	MC3	MC4	MC5	MC6
COMPENSATION FACTOR	1	1	1	1	2	2

MEASURING LOAD IS AS FOLLOWS.
MINIATURE BEARINGS 2.5N (0.25kgf)
SMALL BEARINGS 4.4N (0.45kgf)

●RADIAL INTERNAL CLEARANCE OF STANDARD RADIAL BALL BEARINGS

NOMINAL BORE DIAMETER d(mm)	CLEARANCE										
			C2		CN(C0)		C3		C4		C5
OVER	INCL.	MIN	MAX	MIN	MAX	MIN	MAX	MIN	MAX	MIN	MAX
10(ONLY)		0	7	2	13	8	23	14	29	20	37
10	18	0	9	3	18	11	25	18	33	25	45
18	24	0	10	5	20	13	28	20	36	28	48
24	30	1	11	5	20	13	28	23	41	30	53
30	40	1	11	6	20	15	33	28	46	40	64
40	50	1	11	6	23	18	36	30	51	45	73

NOTE: 1. FOR MEASURING CLEARANCE, OFFSET BY COMPENSATION FACTOR LISTED BELOW.

BORE DIAMETER OF NOMINAL BEARING d(mm)		MEASURING LOAD	COMPENSATION FACTOR				
OVER	INCL.	N (kgf)	C2	CN(C0)	C3	C4	C5
10(INCLUDED)	18	24.5 (2.5)	3~4	4	4	4	4
18	50	49 (5)	4~5	6	6	6	6

RELATIONSHIP BETWEEN RADIAL INTERNAL CLEARANCE AND AXIAL INTERNAL CLEARANCE

The axial internal clearance is established from the ball diameter, outer and inner ring raceway radius and the radial internal clearance. Usually it is about 10 times the value of the internal radial clearance. Selection of a small internal radial clearance or an extra large interference fit in order to reduce the internal axial clearance after mounting is not recommended.

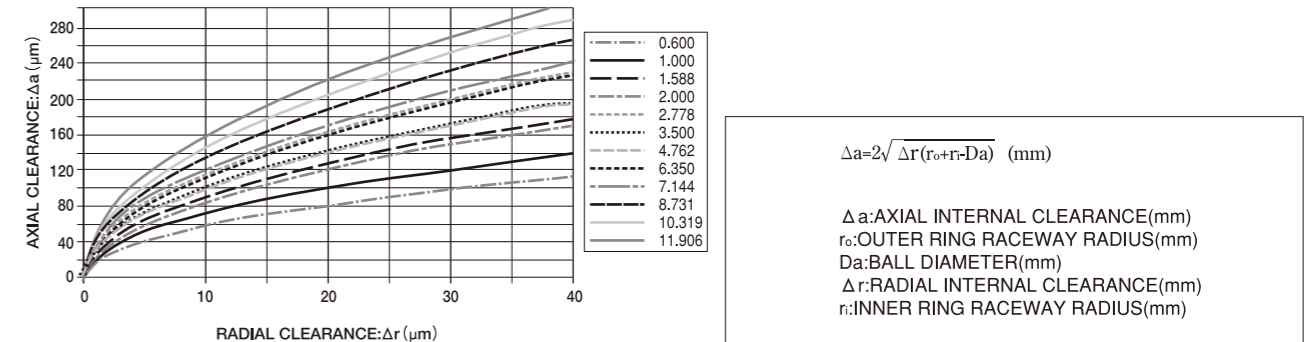

SELECTION OF BEARING CLEARANCE

Theoretically, maximum bearing life is with very slight preload. However, even a slight increase in this theoretical preload can have a considerably detrimental effect on the bearing life. Positive clearance should therefore be selected. MC3 is usually used for miniature or small bearings, standard clearance for general bearings and the clearance for thin section bearings should never be greater than "standard".

●SELECTION OF RADIAL INTERNAL CLEARANCE

Operating Condition	Clearance
Clearance fit for inner and outer ring. Low axial load. No axial load carrying requirement. Select bearing with reduced radial clearance. Lower vibration and noise. Low speeds.	MC1, MC2, C2
Lower frictional torque. Standard axial load. Average axial load carrying requirements. Slight interference fit for inner ring. Clearance fit for outer ring. Average/low speeds.	MC3, MC4, CN(C0)
Extremely low frictional torque. High axial load. High axial load carrying requirements. Heavy interference fit to support high loads or shock loads. Large temperature gradient from inner ring to outer ring. High degree of shaft deflection.	MC5, MC6, C3, C4, C5

CALCULATION OF CLEARANCE

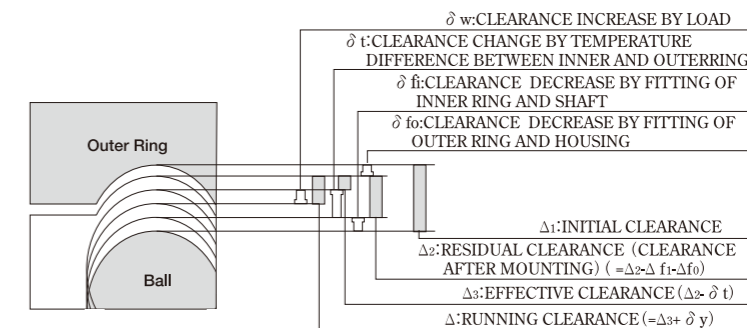

(1) RUNNING CLEARANCE

Running clearance is the resultant clearance after load, temperature difference and fitting are taken into consideration.

$$\Delta = \Delta i - (\delta t + \delta f) + \delta w \quad (\text{mm})$$

(2) CLEARANCE REDUCTION BY TEMPERATURE DIFFERENCE BETWEEN INNER AND OUTER RING

In a bearing, the highest temperature is generated in the rolling element followed by the inner ring, with the outer ring having the lowest temperature. Since it is impossible to measure the temperature of a rolling element, in practice, the temperature of the inner ring is used.

$$\delta t = a \times \Delta T \times D_o \quad (\text{mm})$$

(3) CLEARANCE REDUCTION BY FITTING

When a bearing is fitted onto a shaft or into a housing with an interference fit, the internal clearance of the bearing reduces.

$$\delta f = \delta f_i + \delta f_o = \Delta db \times d / db \times ((1 - (d_o/d)^2) / (1 - (d_o/db)^2)) + \Delta Da \times Da / D \times ((1 - (D/D_h)^2) / (1 - (Da/D_h)^2)) \quad (\text{mm})$$

(4) CLEARANCE INCREASE BY LOAD

Load on a bearing deforms it elastically and increases the internal clearance.

$$\delta w = C \times ((5 \times Fr) / (Z \times \cos \alpha))^{(2/3)} \times (1/dw)^{(1/3)} \quad (\text{mm})$$

The initial contact angle α_0 is calculated from the following two formulae:
 $\cos \alpha_0 / \cos \alpha = 1 + C / (2 \times m - 1) \times (Fa / (9.8 \times Z \times D_w^2 \times \sin \alpha))^{(2/3)}$
 $1 - \cos \alpha_0 = \Delta r / (2 \times DW \times (2 \times m - 1))$

SYMBOLS

ΔT : TEMPERATURE DIFFERENCE BETWEEN INNER AND OUTER RING	m : OSCULATION
D_o : OUTER RING RACEWAY DIAMETER	Z : NUMBER OF BALLS
Δdb : CLEARANCE OF INNER RING ON SHAFT	D_w : BALL DIAMETER
d_o : BORE DIAMETER OF HOLLOW SHAFT	α : CONTACT ANGLE
D_n : OUTSIDE DIAMETER OF HOUSING SEAT	α_0 : INITIAL CONTACT ANGLE
ΔDa : CLEARANCE OF OUTER RING IN HOUSING	F_a : AXIAL LOAD
db : AVERAGE OUTSIDE DIAMETER OF INNER RING	F_r : RADIAL LOAD
Da : AVERAGE OUTSIDE DIAMETER OF OUTER RING	Δr : RADIAL INTERNAL CLEARANCE
a : COEFFICIENT OF THERMAL EXPANSION FOR BEARING STEEL	C : MATERIAL ELASTICITY FACTOR

General Bearing	C=0.00218	m=0.525
Instrument Bearing	C=0.00287	m=0.560

REQUIRED CHARACTERISTICS OF THE LUBRICANT

- (1) LOW FRICTION AND ABRASION
- (2) HIGH STABILITY AGAINST HEAT, GOOD THERMAL CONDUCTIVITY
- (3) STRONG OIL FILM
- (4) NON-CORROSIVE
- (5) PROVIDE A GOOD BARRIER AGAINST DUST AND MOISTURE
- (6) MAINTAIN A STABLE VISCOSITY

STANDARD LUBRICANT

Lubricant	Brand	EZO CODE	Manufacturer	MIL STANDARD	Operating Temperature(C)	specific gravity
STD.GREASE	MULTEMP SRL	SRL	Kyodo Yushi		-40~+150	0.93
	ALVANIA 2S	AV2	Shell OIL Co.		-25~+120	0.92
STD. OIL	AERO SHELL FLUID 12	AF2	Shell OIL Co.	MIL-PRF-6085D	-50~+205	0.93

LUBRICATION METHOD

There are two types of lubricant: oil or grease. It is important to select the correct lubricant and lubrication method for each application and its conditions.

●LUBRICATING OIL AND GREASE

	LUBRICATING OIL	LUBRICATING GREASE
ROTATING SPEED	LOW · MEDIUM · HIGH SPEED	LOW · MEDIUM SPEED
LUBRICANT EFFICIENCY	EXCELLENT	GOOD
COOLING EFFECT	GOOD	NONE
TORQUE	COMPARATIVELY LOW	COMPARATIVELY HIGH
LUBRICANT LIFE	LONG	COMPARATIVELY SHORT
LUBRICANT REPLACEMENT	EASY	DIFFICULT
LUBRICANT LEAKAGE	SHOULD NOT BE USED WHERE OIL LEAKAGE IS UNACCEPTABLE	LITTLE GREASE LEAKAGE
IMPURITIES FILTRATION	EASY	DIFFICULT
SEALING EQUIPMENT	COMPLEX	SIMPLE

●GREASE FILLING VOLUME

SYMBOL	FILLING VOLUME(%)	OPERATING CONDITION	
		SPEED	LOAD
M	70±10	LOW	HEAVY
S	50±10	LOW	MEDIUM
G	40±10	MEDIUM	MEDIUM
L	30±10	MEDIUM	MEDIUM
Q	25±5	MEDIUM	MEDIUM
K	20±5	HIGH	LIGHT
X	10±5	HIGH	LIGHT

NOTE: LIGHT LOAD (≤0.06Cr)
STANDARD LOAD (≤0.12Cr)

Lubrication

OBJECT OF LUBRICATION

The lubrication method and the lubricant have a direct effect on the bearing life; the most suitable lubrication must therefore be selected for each application. Effects of lubrication are described as follows:

(1) DECREASE OF FRICTION AND ABRASION

It decreases rolling friction between the raceway and the rolling elements, sliding friction between rolling element and cage and sliding friction of guide surface between the cage and the bearing ring.

(2) REDUCTION OF HEAT GENERATION

It dissipates heat generated inside the bearing as well as heat conducted from the outside thus preventing overheating of the bearing and deterioration of the lubricant.

(3) PROTECTION FROM CORROSION AND CONTAMINANTS

It prevents corrosion of rolling elements, bearing rings and cages and also prevents the ingress of contaminants and moisture into the bearing.

●CRITERIA FOR LUBRICATING OIL SELECTION

OPERATING TEMPERATURE OF BEARING (°C)	dn	ISO VISCOSITY GRADE OF LUBRICATING OIL(VG)	
		MEDIUM LOAD	HEAVY LOAD/SHOCK LOAD
-30~0	UP TO PERMISSIBLE ROTATING SPEED	15,22,32	32,46
0~+60	UP TO 15000	32,46,68	100
	15000~80000	32,46	68
	80000~150000	22,32	32
	150000~500000	10	22,32
+60~+100	UP TO 15000	150	220
	15000~80000	100	150
	80000~150000	68	100,150
	150000~500000	32	68
+100~+150	UP TO PERMISSIBLE ROTATING SPEED	320	

NOTE: 1. IF HEAVY LOADS OCCUR AT LOW SPEEDS, A HIGHER VISCOSITY LUBRICATING OIL SHOULD BE USED.
 2. THIS TABLE IS FOR OIL BATH LUBRICATION SYSTEM AND RECIRCULATING OIL SYSTEMS.
 3. dn = BEARING BORE DIAMETER d(mm) × ROTATING SPEED n(r.p.m)

●COMMON OIL BRANDS AND EFFICIENCY

Manufacturer	Brand	Code	Lubricant Base	Flash Point (°C)	Viscosity (m ² /s)	Operating Temperature (°C)	Approved Standard
Shell Oil Co.	Aero Shell Fluid 31	AF1	Diester	237	14.33 (40°C)	-40~+204	MIL-PRF-83282D
	Aero Shell Fluid 12	AF2	Diester	220	8.9 (54.4°C)	-54~+135	MIL-PRF-6085D
	Aero Shell Fluid 3	AF3	Mineral	155	10.0 (38°C)	-47~+115	MIL-PRF-7870C
Anderson Oil Co.	Windsor Lube L-245X	WL2	Diester	215	14.0 (38°C)	-55~+175	MIL-PRF-6085D
Dupont, E.I.	Krytox 143AZ	KAZ	Fluorinated	-	12.4 (40°C)	-54~+149	-
Kluber Lub.	Isoflex PDB38	PD8	Diester	210	12.0 (40°C)	-55~+100	-
Anderol Co.	Anderol 402	A42	Diester	227	12.4 (40°C)	-54~+177	MIL-PRF-6085D
JX Nippon Oil Energy.	Antirust P2100	002	Mineral	166	13.0 (40°C)	-20~+115	VV-L-800c

●COMMON GREASE BRANDS AND EFFICIENCY

Manufacturer	Brand	Code	Thickening Agent	Lubricant Base	Drop Point (°C)	Cone Penetration (60 strokes)	Operating Temperature (°C)	Approved Standard
Shell Oil Co.	Alvania 1S	AV1	Lithium	Mineral	182	323	-35~+120	-
	Alvania 2S	AV2	Lithium	Mineral	185	275	-25~+120	-
	Alvania 3S	AV3	Lithium	Mineral	185	242	-20~+135	-
	Alvania RLQ2	AQ2	Lithium	Mineral	195	275	-30~+120	-
	Aero Shell NO.7	AG7	Microgel	Diester	260	296	-73~+149	MIL-PRF-83282D
	Aero Shell NO.14	AG4	Calcium	Diester	148	273	-54~+93	MIL-G-25537C
	Aero Shell NO.15	AG5	Fluorotolomer	Silicone	260	290	-73~+232	MIL-G-25013E
	Aero Shell NO.22	AG2	Microgel	Synthetic Hydrocarbon	260	275	-65~+204	MIL-PRF-81322F
	Aero Shell NO.33MS	A3S	Lithium	Synthetic Hydrocarbon Ester	234	281	-73~+121	MIL-G-21164D
	Alvania EP2	AE2	Lithium	Mineral	184	284	-20~+110	-
	Shell Cassida HDS2	HS2	Aluminum Complex	PAO	240	280	-30~+120	NSF(USDA)H1
	Shell Cassida RLS2	RL2	Aluminum Complex	PAO	240	275	-35~+120	NSF(USDA)H1
	Multemp PS NO.2	PS2	Lithium	Diester, Mineral	190	275	-55~+130	-
	Multemp SRL	SRL	Lithium	Diester, Mineral	191	245	-50~+150	-
Kyodo Yushi	Staburags NBU12	NB2	Barium	Mineral	220	270	-35~+150	NSF(USDA)H2
	Staburags NBU12/300KP	NB3	Barium	Mineral	220	300	-35~+150	-
	Staburags NBU8 EP	NB8	Barium	Mineral	220	280	-35~+150	NSF(USDA)H2
	Isoflex NBU15	NB5	Barium	Diester, Mineral	200	280	-40~+130	MIL-G-25760A
	Isoflex TOPAS NB52	B52	Barium	Synthetic Hydrocarbon	220	280	-60~+160	-
	Isoflex Alltime SL2	AS2	Lithium	Diester	180	280	-70~+150	-
	Isoflex LDS18 Special A	L8A	Lithium	Diester	190	280	-60~+130	MIL-G-23827B
	Isoflex Super LDS18	SL8	Lithium	Diester	190	280	-60~+130	MIL-G-7118A
	Isoflex PDB38 CX2000	PDC	Lithium	Synthetic	-	-	-70~+120	-
	Barielta IEL	IEL	PTFE	Fluorinated	-	280	-35~+220	-
	Barielta IEL/V	IEV	PTFE	Fluorinated	-	280	-65~+200	-
	Barielta IMI	IMI	PTFE	Fluorinated	-	280	-50~+220	-
	Barielta IMI/V	IMV	PTFE	Fluorinated	-	280	-50~+220	-
	Barielta L55/2 H1	L55	PTFE	Fluorinated	-	280	-35~+260	NSF(USDA)H2
Barielta IS	BSI	PTFE	Fluorinated	-	280	-35~+260	-	
Dow Corning Co.	Klubersynth UH1 64-62	UH6	Silicate	Synthetic Hydrocarbon	-	280	-40~+150	NSF(USDA)H1
	Molykote 33M	M3M	Lithium	Silicone	200	260	-70~+180	-
	Molykote 33L	M3L	Lithium	Silicone	200	300	-70~+180	-
	Molykote 44M	M4M	Lithium	Silicone	210	260	-40~+200	-
	Molykote BR2 Plus	BR2	Lithium	Mineral	180	280	-30~+150	-
	Molykote FS3451	F35	PTFE	Fluorinated	232	310	-40~+200	-
Dupont, E.I.	Krytox 240AC	K24	PFPE	Fluorinated	-	282	-35~+288	MIL-G-27617
	Krytox 240AZ	K2Z	PFPE	Fluorinated	-	285	-54~+149	MIL-G-27617
Esso Standard	Beacon325	B32	Lithium	Diester	190	274	-60~+120	-
	Templex N3	TX3	Lithium Complex	Mineral	260	230	-30~+160	-
Mobil Oil Co.	Mobil NO.28	MG2	Bentnite	Synthetic Hydrocarbon	262	280	-62~+204	MIL-G-81322E
	Mobilux EP2	ME2	Lithium	Mineral	202	280	-30~+130	-
Nippon Grease Co.	Nig Ace W	NAW	Diurea	Synthetic	268	256	-30~+150	-
Shinetsu Chemical Co.	Silicolube G40M	G40	Lithium	Silicone	210	260	-30~+200	MIL-L-15719A



Maximum permissible bearing speed

Each bearing type has its own limiting speed. The theoretical speed that bearings can run at safely, even if heat generation by internal friction occurs, is called the maximum permissible speed. The permissible speed is related to bearing type, type of cage, lubricant type, load and cooling conditions to which the bearing is subjected. For contact rubber seals(2RS type), the permissible speeds are limited by the peripheral velocity of the seal lip. Normally, this is approximately 50 - 60% of that of non-contact rubber seals. If light contact rubber seals are required, this must be stipulated with the order. If high loads occur, the permissible speed values must be reduced and the following supplementary factors applied, except under standard operating conditions(Cr/P<12, Fa/Fr>0.2)

●COMPENSATION FOR MAXIMUM PERMISSIBLE SPEED DEPENDENT ON LOAD RATIO

Cr/P	5	6	7	8	9	10	11	12
COMPENSATION FACTOR	0.72	0.79	0.85	0.90	0.93	0.96	0.98	1.00

●COMPENSATION FOR MAXIMUM PERMISSIBLE SPEED UNDER COMBINED AXIAL AND RADIAL LOAD

Fa/Fr	0.25	0.50	0.75	1.00	1.25	1.50	1.75	2.00
COMPENSATION FACTOR	1.00	0.95	0.93	0.91	0.89	0.88	0.87	0.86

If the bearing operates at over 70% of the permissible speed value, a lubricant for high speed should be selected. The values for the permissible speed are for applications with horizontal shafts and with appropriate lubrication. With vertical shafts, only 80% of the maximum speed value should be used. This is necessary due to the reduced cage guidance and reduced lubricant retention in this type of application.



Frictional torque and temperature

FRICITIONAL TORQUE

Frictional torque of rolling bearings varies under changing load and lubrication conditions. When grease is used as a lubricant, the grease resistance must be added to the bearing frictional torque. When adequate lubrication under normal loading conditions(Cr/P>12, Fa/Fr<0.2), the frictional torque of a bearing can be expressed as follows:

$$M = \mu \cdot F \cdot d/2 \text{ (N}\cdot\text{mm)}$$

M: FRICTIONAL TORQUE (N·mm)
 F: BEARING LOAD (N)
 d: SHAFT DIAMETER (mm)
 μ : 0.0015 COEFFICIENT OF FRICTION

TEMPERATURE INCREASE

Friction and grease resistance can increase the bearing temperature. In the initial stages of operation, the internal bearing temperature rises rapidly: as the heat dissipates to the shaft and housing and the cooling effect of the lubricant begins to take effect, the temperature stabilizes. Constant high temperatures lead to a reduction in bearing clearance, a deterioration of the running accuracy and of the lubricant and thereby a reduction in bearing life. It is important to consider the effect of temperature increases when selecting the bearing.

- After assembly, the bearing should be rotated to check its correct operation. If the bearing does not appear to be functioning correctly, it should be re-examined to establish the cause of the malfunction.
- It is not advisable to mix oils and greases as this will affect the efficiency of the bearing.
- Bearings must be stored in a clean environment with stable temperature. They should be handled with care to avoid the possibility of corrosion and rusting.
- Lint-free cloth must be used to wipe shaft and housing seats to avoid the ingress of contaminants into the bearing.

Technical

Dimension



Basic rules for selecting and handling of bearings

NOTES ON SELECTING

- ◆ The efficiency of thin type bearings can be greatly affected by the precision of shaft and housing seats. The accuracy of the surrounding structure must be such that it will not adversely affect the operation of the bearing. If you have any questions, in particular regarding series 670 and 680, please contact us.
- ◆ In applications with steel crown type cages (w type), where high acceleration, heavy loads, shock loads or vertical shafts occur or where oil is the only lubricant available, please contact us.
- ◆ Selection of fitting clearance and grease type requires a careful consideration of rotating speed, load conditions and temperature in order to prevent premature bearing failure.
- ◆ Full complement ball bearings are suitable for low speed and heavy radial load conditions. There is a danger of balls being pushed out of the bearing through the filling slot, even under light axial load. For this reason, full complement ball bearings are not suitable for supporting axial loads.

NOTES ON HANDLING

- The actual assembly area should be kept free from dust as any contamination has a detrimental effect on the operation and life of rolling bearings. If there is any doubt concerning the cleanliness of a bearing, it can be washed with a suitable agent and then relubricated.
- When fitting bearings, the fitting forces must not be transmitted via the rolling elements. If it is necessary to heat the bearing to facilitate fitting, the temperature should not exceed +120°C.



Problem, Cause, Remedy

PROBLEM		CAUSE	REMEDY
Noise	High pitched metallic noise	Poor lubrication	Improve lubrication
		Clearance too small	Correct clearance
		Poor fitting	Investigate mounting method and seating
		Excessive load	Examine shaft and housing tolerances for closing effect
	Low pitched metallic noise	Brinelled raceway surface	Avoid shock loads
	Regular noise	Rust and damage	Check and replace seals and relubricate
		Flaking of raceway surface	Improve lubrication and check fitting, clearance and fixing method
	Irregular noise	Ingress of foreign matter	Check and replace seals and relubricate
		Excessive clearance	Correct clearance
		Damage and flaking of rolling element	Reduce loads and/or clearance
Variable noise	Variable clearance due to temperature changes	Check fits taking housing material and temperature into consideration	
	Damage to raceways	Improve lubrication and check fitting, clearance and fixing method	
Heavy vibration	Flaking of raceway and rolling element	Improve lubrication and check fitting, clearance and fixing method	
	Ingress of foreign matter	Check and replace seals and relubricate	
	Excessive clearance	Correct clearance	
	Poor location	Ensure abutment face and fitting diameter are perpendicular	
Excessive heat generation	Clearance too small	Correct clearance	
	Poor location	Ensure abutment face and fitting diameter are perpendicular	
	Excessive load	Examine shaft and housing tolerances for closing effect	
	Poor lubrication	Improve lubrication	
	Creep	Maintain recommended shaft and housing fits	
Lubrication failure	Too much grease	Use correct lubricant quantity	
	Ingress of foreign matter	Check and replace seals and relubricate	

Damage, Cause, Remedy

Incorrect handling of bearing can cause damage and shorten the life. The following list shows typical causes and suggested remedies.

PROBLEM	DAMAGE	CAUSE	REMEDY
Flaking	Flaking on one side of entire raceway	Excessive axial load by poor fitting or linear expansion	Use clearance fit on non-rotating bearing outer ring
	Flaking at rolling element pitch on raceways	Raceways brinelled during fitting	Careful fitting
		Corrosion during down time	Apply corrosion protective
	Premature flaking of raceway and rolling element surfaces	Excessive load	Check fitting Correct clearance Use correct lubricant quantity
		Clearance too small	
		Poor lubrication	
Poor fitting			
Flaking across the raceway	Corrosion	Fitting and centering with care Use bearing with larger internal clearance Shaft and abutments to be square	
	Poor fitting and eccentricity		
	Shaft deflection		
Flaking around raceway	Geometric inaccuracy of shaft and housing	Check geometric accuracy of housing bore	
	Poor housing accuracy		
Indentations	Indentations on raceway at rolling element pitch	Shock loads during fitting or poor handling	Handling with care
		Excessive static load	Check static load
	Overrolling	Ingress of foreign matter	Ensure cleanliness of components and integrity of seals
Pick-up	Discolouration of raceway and rolling element surface	Excessive load	Check fitting
		Clearance too small	Correct clearance
	Softening of surfaces	Poor lubrication	Use correct lubricant quantity
Electrical erosion	Raceway eroded at regular intervals	Poor fitting	Check fitting method
		Arcing due to bearing conducting electricity	Ground the bearing, Insulate the bearing
Fracture	Raceway surface fracture	Excessive shock loads	Correct loading
		High interference fit	Proper fitting
		Increase of flaking and softening, welding of inner ring to shaft	Ensure correct geometry of shaft and housing
	Rolling element fracture	Corner fillet radii too large	Correct fillet radii
		Excessive shock loads	Correct loading
	Cage fracture	Excessive internal clearance	Check fitting and clearance
Tilting moments		Fit with care	
High speed impulse and high acceleration		Ensure uniform rotation	
Skidding	Scoring of raceway and rolling element surfaces	Incorrect lubrication	Check lubricant and lubrication method
		Ingress of foreign matter in bearing	Improve sealing
		Hard grease	Use soft grease
Abrasion	Extreme abrasion of raceway, rolling element and cage	High start-up acceleration	Control acceleration
		Ingress of foreign matter	Improve sealing
		Corrosion	Improve lubrication
	Creep	Poor lubrication	Correct tolerances and fitting
		Loose fit	Correct fixing
Fretting corrosion	Incorrectly fixed	Increase interference fit	
Corrosion	Rust inside bearing	Small movements between surfaces	Insulate bearing from vibration Use oil as lubricant Apply preload
		Vibration in non-rotating bearing	Careful storage and handling
	Rust on fitting surface	Condensation	Increase interference fit
Corrosion	Rust on fitting surface	Fretting	Use oil as lubricant
		Fluctuating load	Check sealing
	Corrosion	Ingress of acid, alkali or gas	Use correct lubricant
		Chemical reaction with lubricant	



SAPPORO PRECISION GROUP'S EFFORTS TOWARD ISO

SAPPORO PRECISION INC.

International quality management system standard ISO 9001



Sapporo Precision Inc. establishes a system for continuously providing services for higher customer confidence and satisfaction for the customers throughout the world



Certificate No: ISO/TS16949 : YKA 4003532
ISO9001 : YKA 4003532

Scope of Organization: Head Office in Sapporo and Shipping Center in Ashibetsu-city

KITANIHON SEIKI CO., LTD.

Proof of excellent environmental preservation and quality control system



Quality assurance supported by trust and actual achievement. We produce bearings with an eye on environmental preservation.



Certificate No: ISO/TS16949 : YKA 4003532
ISO9001 : YKA 4003532
ISO14001 : JQA-EM0554

Scope of Registration: The design/Development and manufacture of ball bearing

SHANGHAI PRECISION BEARING CO., LTD.

Quality improvement meeting international standards



It provides products of equivalent standard and quality to the world market as one of the Sapporo Precision group companies under the same quality control system



Certificate No: ISO9001 NO.02010Q20364FROM
ISO14001 NO.02010E20428FROM
Scope of Registration: Production of Miniature Bearings



SAPPORO PRECISION INC.

8-2 South 1, East 2, Chuo-ku
Sapporo, Hokkaido 060-0051 Japan
PHONE:81- (0)11-251-9261 FAX:81- (0)11-251-9266

URL: <http://www.sppc.co.jp>

E-mail: info@sppc.co.jp



YKA 4003532



YKA 4003532

KITANIHON SEIKI CO., LTD.

26-23 Kamiashibetsu-Cho
Ashibetsu, Hokkaido 079-1397 Japan
PHONE:81- (0)124-22-1250 FAX:81- (0)124-22-1038

URL: <http://www.ezo-brg.co.jp>



YKA 4003532



YKA 4003532



JQA-EM0554

SHANGHAI PRECISION BEARING CO., LTD.

345 Minshen Road , Songjiang
Industrial Zone , Shanghai , 201612 China
PHONE:86- (0)21-67600758 FAX:86- (0)21-67600777

URL: <http://www.spb.com.cn>



ISO 9001
NO. 0210Q20364ROM



ISO 14001
NO. 02010E20428ROM