



*The wise choice for* **U**ltra **R**eliable **B**earings

**URB GROUP**

**PETROLEUM INDUSTRY**  
**Special and Standard**  
**Bearings**



**URB GROUP**



320 Republicii Street,  
731108 Barlad,  
ROMANIA



phone: +40 235 / 411120, 412120  
fax: +40 235 / 413838, 308200  
[www.urbgroup.com](http://www.urbgroup.com)

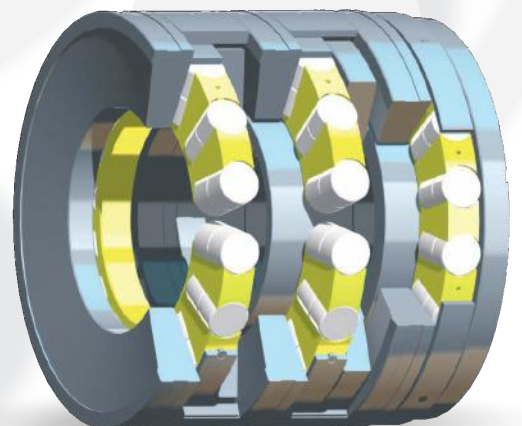

## Introduction

As global oil and gas requirements are expected to increase by 30% over the next 20 years, URB has a wide range of solutions to help customers increase production, reduce maintenance costs, extend the life of equipment and reduce energy consumption.

Either this is possible only if we provide quality bearings incorporating new technologies that can provide improved performance in new and demanding applications.

Bearings for applications offshore, drilling rigs, such as mud pumps, winches and rotary tables of drilling that need to operate in the toughest conditions on (and in) the Earth. Our company provides technical support through counseling and guidance on mounting and dismounting of bearings, recommendations on suitable lubricants and inspection of bearings used properly.

URB company is able to work with customers to recommend optimal bearings for each application to provide maximum life and minimum space requirements

Our company offer specifically designed bearings for high thrust loads and have ready to meet the requirements for quality and performance. The material used 100CrMo7-3. It has good hardenability and strength, good temperature resistance and stability.

The tandem design allows the use of a high thrust capacity bearing in a small area. It was originally designed for a rotary swivel used on an oil drilling ring.

## Standard Bearings

### Cylindrical Roller Bearings

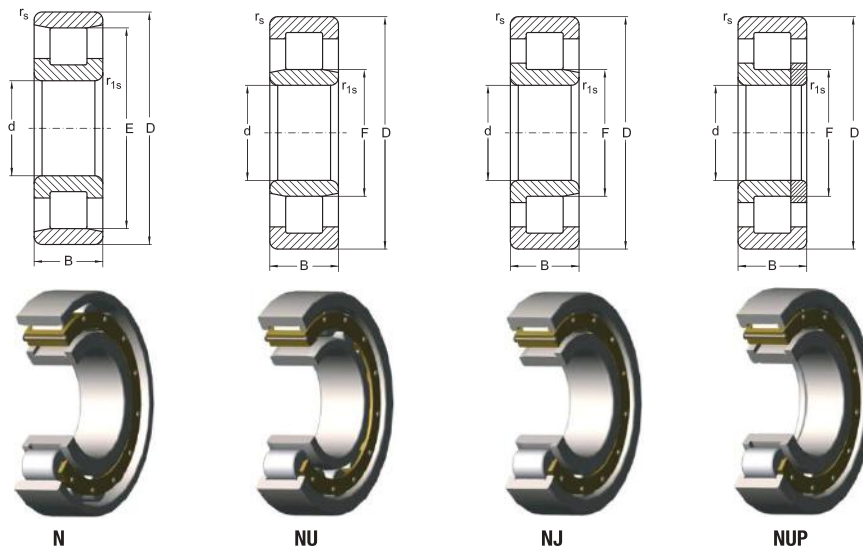

Designation	Dimensions mm			Basic radial load kN		Speed limits min <sup>-1</sup>		Weight kg
	d	D	B	dyn.	stat.	grease	oil	
NU1020 M	100	150	24	98	134	4300	5000	1.5
NU220 EM	100	180	34	254	313	3400	4000	0.65
NJ2320 EM	100	215	73	574	717	2600	3200	13.2
NU2320 M	100	215	73	574	717	2600	3200	13.9
NJ222 EM	110	200	38	279.2	343.3	3000	3600	5.56
NJ322 EM	110	240	50	400	310	2400	3000	11.6
NU2322 EM	110	240	50	443	513	2400	3000	12.8
NJ2322 EM	110	240	80	682	540	2200	2800	19.3
NJ224 EM	120	215	40	260	183	2800	3400	5.9
NU224 EM	120	215	40	260	183	2800	3400	5.8
N324 M	120	260	55	430	338	2200	2800	15.3
NU2324 EM	120	260	86	780	1020	2000	2600	23.5
NJ326 EM6	130	280	58	627	455	2000	2600	18.9
NJ2326 EM	130	280	93	915	1220	1900	2400	29.6
NU2326 EM	130	280	93	915	1220	1900	2400	29.6
NU1028 M	140	210	33	183	265	2800	3400	4.1
NJ2328 EM	140	300	102	1130	1589	1800	2200	37.2
NU2328 EM	140	300	102	1130	1589	1800	2200	37.2
NJ230 EM	150	270	45	440	585	2200	2800	11.8
NU230 EM	150	270	45	440	585	2200	2800	11.8
NJ2230 EM	150	270	73	655	980	2000	2600	19.5
NU2230 EM	150	270	73	655	980	2000	2600	19.5

Designation	Dimensions mm			Basic radial load kN		Speed limits min <sup>-1</sup>		Weight kg
	d	D	B	dyn.	stat.	grease	oil	
NJ330 EM	150	320	65	800	1000	1800	2200	27.5
NU330 EM	150	320	65	800	1000	1800	2200	27.5
NJ2330 EMA6	150	320	108	1160	1600	1700	2000	44.8
NJ1032 M	160	240	38	245	355	2400	3000	6.2
NU1032 M	160	240	38	245	355	2400	3000	6.1
NU2232 EMC3	160	290	80	800	1180	1900	2400	24.5
NJ2332 EM	160	340	114	1320	1830	1600	1900	53.5
NU2332 EM	160	340	114	1320	1830	1600	1900	53.5
NJ234 EM	170	310	52	618	828	1800	2200	17.9
NU234 EM	170	310	52	618	828	1800	2200	17.9
NJ334 EM	170	360	72	928	1150	1600	1900	38
NJ2334 M	170	360	120	1220	1760	1500	1800	63.5
NU2334 M	170	360	120	1220	1760	1500	1800	63.5
NU1036 M	180	280	46	360	520	2200	2800	10.9
NU336 M	180	380	75	900	1160	1500	1800	44
NU338 EM	190	400	78	1132	1460	1400	1700	50.4
NJ240 EM	200	360	58	750	1050	1600	1900	26.9
NU240 EM	200	360	58	750	1040	1600	1900	26.9
NJ1044 M	220	340	56	650	1047	1700	2000	19.3
NU1044 M	220	340	56	650	1047	1700	2000	19.1
NU344 M	220	460	88	1230	1650	1300	1600	75.5
NU1048 M	240	360	56	695	1168	1600	1900	20.7
NU1052 M	260	400	65	660	1039	1500	1800	30.8
NU1056 M	280	420	65	680	1100	1400	1700	32.8
NU260 M	300	540	85	1400	2040	1100	1400	89.9

### Spherical Roller Bearings

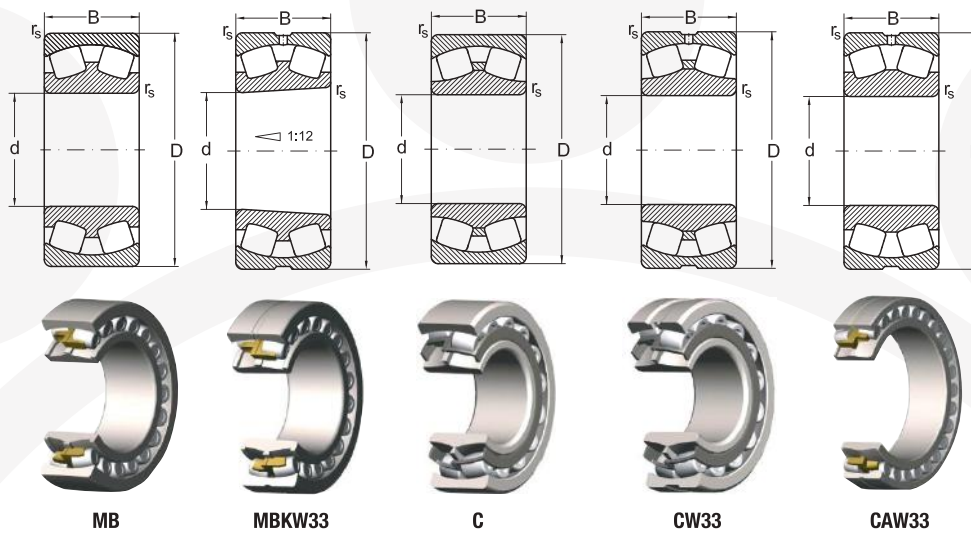

Designation	Dimensions mm			Basic radial load kN		Speed limits min <sup>-1</sup>		Weight kg
	d	D	B	dyn.	stat.	grease	oil	
22320 CW33	100	215	73	730	960	1500	2000	12.83
22222 CW33	110	200	53	590	770	1800	2400	7.45
22222 MBW33	110	200	53	540	700	1700	2200	7
22322 CW33	110	240	80	870	1160	1400	1900	18.0
22322 MBW33	110	240	80	800	1060	1300	1700	18.7
22224 CW33	120	215	58	560	800	1700	2200	8.8
22224 MBW33	120	215	58	510	740	1500	2000	9.73
22324 CW33	120	260	86	1010	1340	1300	1700	23.52
22324 MBW33	120	260	86	930	1230	1100	1500	23.18
23126 MBW33	130	210	64	540	860	1500	2000	8.62
24126 MBW33	130	210	80	650	1100	900	1200	11.06
22226 CW33	130	230	64	660	960	1700	2200	10.01
22226 MBW33	130	230	64	600	880	1500	2000	11.47
22326 CW33	130	280	93	1170	1580	1200	1600	28.82
22326 MBW33	130	280	93	1080	1450	1100	1400	28.25
23028 CW33	140	210	53	475	820	1700	2200	7.13

Designation	Dimensions mm			Basic radial load kN		Speed limits min <sup>-1</sup>		Weight kg
	d	D	B	dyn.	stat.	grease	oil	
23028 MBW33	140	210	53	435	750	1500	2000	6.08
23128 MBW33	140	225	68	600	990	1400	1800	10.69
22228 CW33	140	250	68	730	1080	1400	1900	14.27
22228 MBW33	140	250	68	670	990	1300	1700	14.27
23228 CW33	140	250	88	960	1500	1100	1400	20.86
23228 MBW33	140	250	88	880	1380	1000	1300	19.19
22328 CW33	140	300	102	1360	1870	1100	1400	36.79
22328 MBW33	140	300	102	1240	1720	1000	1300	35.17
23030 MBW33	150	225	56	480	830	1400	1800	8.11
23030 CW33	150	225	56	520	900	1500	2000	8.51
22330 MBW33	150	320	108	1400	1940	1000	1300	41.85
22330 CW33	150	320	108	1520	2110	1100	1400	44.6
24132 CW33	160	270	109	1250	2110	850	1100	24.96
22232 CW33	160	290	80	1040	1550	1300	1700	23.6
22332 CW33	160	340	114	1660	2350	1000	1300	52.7
24134 CA	170	280	109	1280	2230	750	1000	27.46
22334 CW33	170	360	120	1850	2590	900	1200	64.88
23036 CW33	180	280	74	870	1500	1300	1700	18.53
23036 MBW33	180	280	74	800	1380	1100	1500	17.03
24036 MBW33	180	280	100	1030	1900	900	1200	22.79
23136 CW33	180	300	96	1260	2110	1200	1600	30.25
23136 MBW33	180	300	96	1160	1940	1100	1400	28.09
24136 CW33	180	300	118	1460	2590	700	950	33.42
24136 CAW33	180	300	118	1460	2590	700	950	33.0
22236 CW33	180	320	86	1210	1870	1100	1500	32.66
22336 CW33	180	380	126	1663	2344	1000	1400	68.1
22336 MBW33	180	380	126	1900	2700	850	1100	71.8
23038 CW33	190	290	75	915	1530	1300	1700	16.08
23038 MBW33	190	290	75	830	1470	1100	1400	18.2
23138 MBW33	190	320	104	1320	2290	1100	1400	35.60
24138 CAW33	190	320	128	1680	3000	670	900	41.6
22238 CW33	190	340	92	1200	1830	1100	1400	37.20
22238 MBW33	190	400	132	1860	2500	750	1000	81.20
22338 MBW33	190	400	132	2000	2920	750	1000	79.6
23040 CW33	200	310	82	1060	1760	1300	1700	21.50
23040 MBW33	200	310	109	1370	2460	850	1100	30.50
23140 CA	200	340	112	1400	2385	1100	1500	43.1
23140 MBW33	200	340	112	1370	2460	1100	1400	43.50
24140 MBW33	200	340	140	1400	2385	560	750	52.5
22240 CW33	200	360	98	1250	2020	1100	1400	44.40
22240 MBW33	200	360	98	1250	2020	1000	1200	44.4
22340 MBW33	200	420	138	1910	2750	670	900	91.80
23044 MBW33	220	340	90	1100	2000	900	1200	31
23144 MBW33	220	370	120	1515	2509	1000	1300	52
22244 MBW33	220	400	108	1485	2483	850	1100	62.8
22344 MBW33	220	460	145	2380	3407	600	800	119.8
23948 MBW33	240	320	60	600	1170	1000	1300	14
23048 MBW33	240	360	92	1160	2200	800	1000	33.9
23148 MBW33	240	400	128	1705	2863	900	1200	66
22248 MBW33	240	440	120	1815	2701	750	1000	85.2
23248 MBW33	240	440	160	2370	3837	560	750	103.4
22348 MBW33	240	500	155	2650	4000	560	750	151
23052 MBW33	260	400	104	1500	2800	750	950	49
24052 MBW33	260	400	140	1775	3494	600	800	66
23152 MBW33	260	440	144	2153	3673	850	1100	92.50
22352 CAW33	260	540	165	3125	4560	600	800	183.8
23056 MBW33	280	420	106	1560	3000	700	900	52.50
23156 MBW33	280	460	146	2295	4050	750	1000	98.50
22256 MBW33	280	500	130	2330	3600	700	950	113
23256 MBW33	280	500	176	2806	4645	480	630	153
23060 MBW33	300	460	118	1960	3650	630	800	73.60
24060 CW33	300	460	160	2385	4702	560	750	96.8
24060 MBW33	300	460	160	2385	4702	500	700	97
23160 CAW33	200	340	112	2635	4485	700	950	43.1
24160 MBW33	300	500	200	3213	6011	430	560	159
23064 CAW33	320	480	121	1935	3727	700	950	79.3
24064 MBW33	320	480	160	2500	5240	530	700	106

Designation	Dimensions mm			Basic radial load kN		Speed limits min <sup>-1</sup>		Weight kg
	d	D	B	dyn.	stat.	grease	oil	
23164 CAW33	320	540	176	3265	5930	670	900	168.7
23264 CAW33	320	580	208	4134	7060	430	560	243.8
23068 MBW33	340	520	133	2360	4500	600	800	105
23072 CAW33	360	540	134	3150	6530	630	850	108.2
24072 CAW33	360	540	180	2950	6230	480	630	146.3
23076 CAW33	380	560	135	2500	6530	600	800	115.4
23080 CAW33	400	600	148	2850	5720	560	750	149.5
23180 CAW33	400	650	200	4105	7705	530	700	263.3

### Angular contact thrust ball bearings

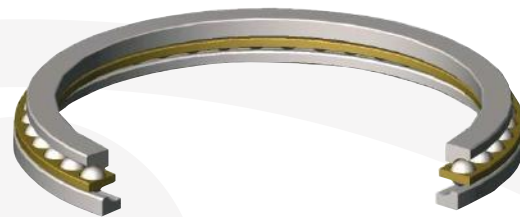
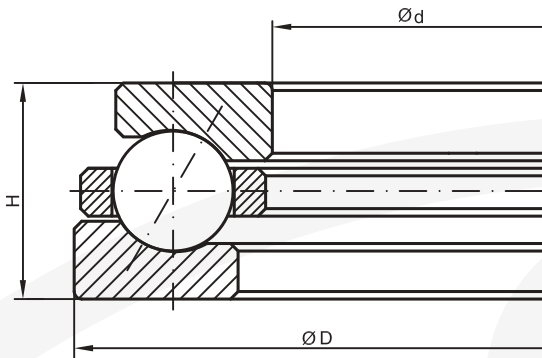

Designation	Dimensions mm			Basic radial load kN		Speed limits min <sup>-1</sup>		Weight kg
	d	D	B	dyn.	stat.	grease	oil	
RY 65/500	500	600	60	407	2066	560	900	26.5
RY 65/530	530	710	109	731	3768	320	530	98
RY 65/600	600	730	98	742	4421	340	560	74.5
RY 65/600 A	600	800	150	1162	6897	260	430	159
RY 65/800 B	800	950	120	611	3703	260	450	124

### Tandem Thrust Bearings

Special requirements:

High reliability, high load carrying capacity in an extremely confined space, in some cases: corrosion resistance

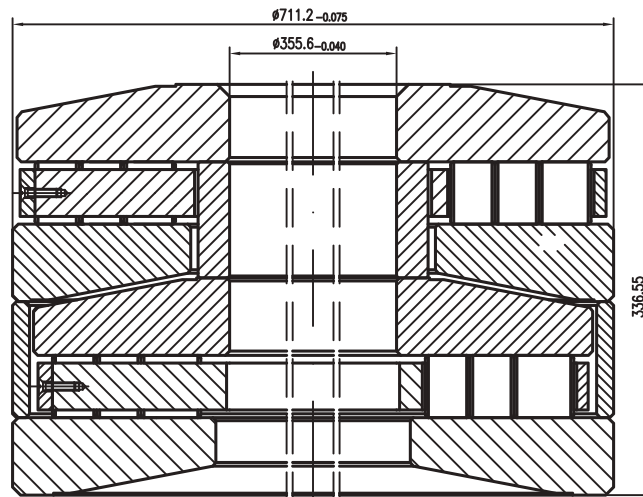

fig. 1

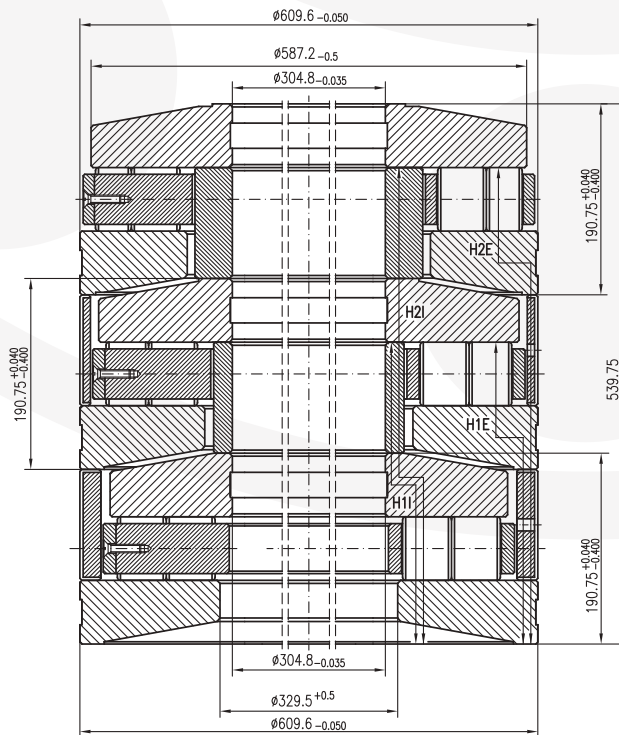
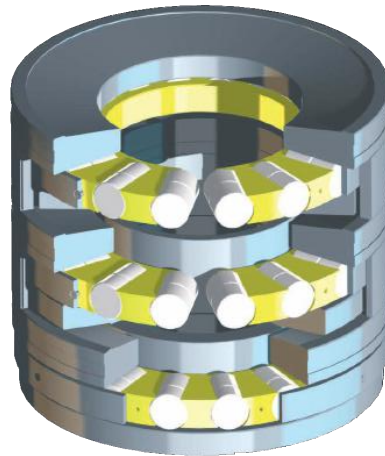

fig. 2



Designation	Dimensions mm			Basic axial load kN	Weight kg	Figure
	d	D	B	dyn.		
TAB-140280-201M	355.6	711.2	336.55	9201	678.044	1
TAC-120240-207M	304.8	609.6	539.75	13500	810.082	2

## Research and development



URB Company with over 60 years experience in designing bearings has the ability to continuously develop new products and services that improve our clients' products. For these investments in technology and specialists specialized software for the calculation and optimization of the existing construction, new materials, metal coatings have been made, increasing the lifetime of our products.

An important factor of quality is continuing design improvement (tapered ribs and roller end crowning to increase the axial load capacity), optimizes lubrication, increases loading capacity, minimizes edge stresses and use polymer cage.

Expert advice and software designed for different applications

### 3D Modeling

Workgroup based, interactive designing in 3D visualization

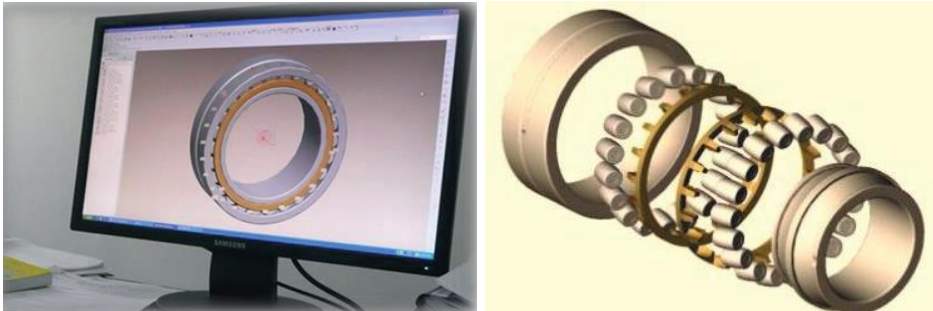

### Finite Element Analysis (FEA)

Finite element tool for structural analysis, including linear, nonlinear and dynamic studies

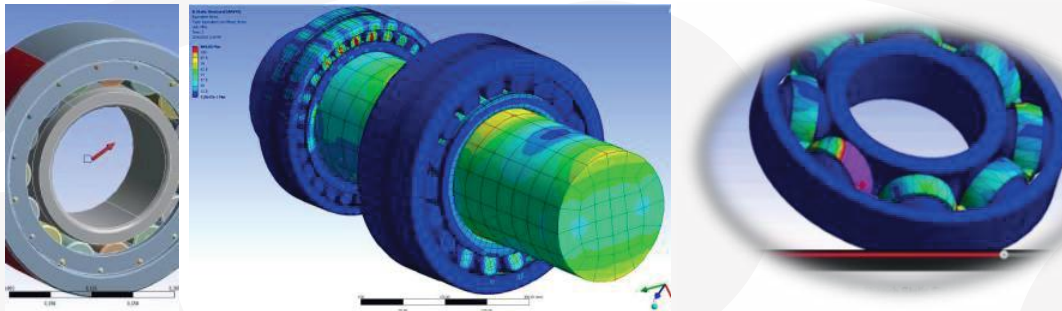

### Rolling Calculation and Shaft Calculation

URB Company use computer programs with finite element simulation taking into account internal bearing geometry and operating conditions.

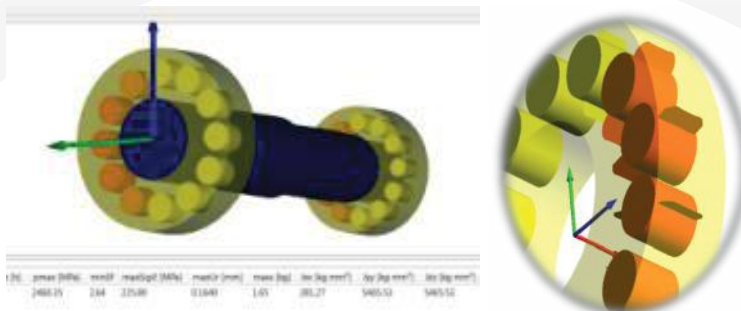

### Visual Xsel v.12.0

Implementing the accurate Weibull analysis for laboratory tests

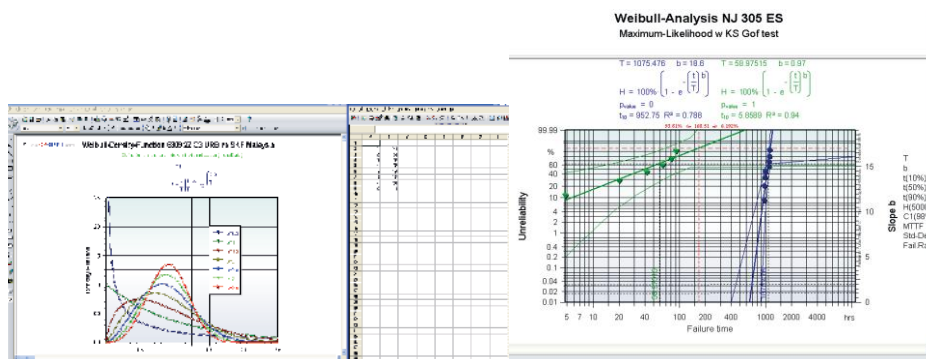

The company was set-up on May 1953 and it has a long tradition in manufacturing of bearings over 60 years, being one of the important bearing manufactures in the Central and South-East Europe.

The key to success has been a consistent emphasis on maintaining the highest quality of our products and services and investment in research and development.

We include the respect for clients and the satisfaction of their needs among our fundamental principles. Therefore we tried to respond better to the market requirements by offering, besides the bearings with standardized shapes and sizes, a large range of non-standardized bearings, specific to various applications.

