



**HepcoMotion®**

**GV3**  
linear guidance and  
transmission system

**HEPCO®**  
[www.HepcoMotion.com](http://www.HepcoMotion.com)

# Introducing the **GV3** linear guidance and transmission system

The GV3 linear guidance and transmission system has been designed to provide the customer with an unrivalled choice of sizes and options to cater for virtually every linear motion requirement.

In devising GV3, Hepco have retained the best features of their highly successful Generation 2 and CM Slide Systems in a greatly expanded range. Many new components have been added including Single Edge Slides, Flat Tracks and drive options.

Customers may now choose Slides from three grades of precision and combine them with either Twin Bearings, Double Row Bearings or low cost Slimline Bearings. This enables the ideal system to be specified for optimum performance within the budget available.

The reliability of Hepco's all steel slideway and V bearing concept has been proved conclusively over nearly fifty years. Improvements are continually being made to this fundamentally sound design resulting in a truly evolutionary system for the 21st century.

By choosing GV3, customers can be assured of a quality and performance which surpasses all expectations.













## GV3 Benefits

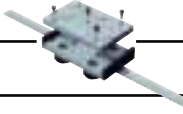

- SMOOTH:**
  - High accuracy and fine finish of components >>>> allows constant driving force without vibration.
  - Friction free motion >>>> allows smaller, lower cost motors to be selected.
- FAST:**
  - Optimised Bearing and Slide interface design >>>> enables very high speeds with low wear.
  - Low stick friction and low inertia of Bearing rotation >>>> allows fast acceleration for shortest stroke.
- ACCURATE:**
  - High degree of Slide parallelism and minimum Bearing clearance >>>> results in virtually zero play.
  - Important dimensions accurately controlled >>>> for reliable system height and positional accuracy.
- QUIET:**
  - Specially designed Bearing and Slide geometry >>>> results in one of the quietest slide systems available.
- DURABLE:**
  - All steel Slideway >>>> three times stiffer than composite aluminium slide systems.
  - Rugged construction >>>> suits high duty applications and harsh environments.
  - Lubrication devices available >>>> maximises life with no relubrication necessary in most instances.
  - Unique wiping action >>>> expels debris in environments where other systems fail.
  - Compliant bearing design >>>> for tolerance of misalignment.
  - Reliable performance confirmed by testing >>>> specify Hepco with confidence.
- SIMPLE:**
  - Easily understood proven technology >>>> little to go wrong and simple to maintain.
- VERSATILE:**
  - Huge range of sizes, types and ancillary components available >>>> provides solution to most design problems.
  - Long lengths available up to 4 m in most sizes >>>> saves on assembly time.
  - Available as assembled unit or in component form >>>> provides maximum flexibility of design.
  - Works in any plane and orientation >>>> unrestricted use in machine construction.
  - Operates without lubrication >>>> ideal for food machinery and clean applications.
  - Driven systems available >>>> complete solutions from a single source saves design and administration time.
- ECONOMIC:**
  - Choice of Slide precision and bearing design >>>> to match cost/performance requirements.
  - Designed for minimum installation time >>>> significantly reduces cost.

# Contents

	Page
<b>System Composition</b> _____	2-7
<b>Application Examples</b> _____	8-16
<b>System Selector</b> _____	17
<b>Data and Dimensions for Individual Components</b>	
<b>Carriages, Carriage Locking Device and Shock Absorber Fixing Blocks</b> _____ 	18-23
<b>'V' Slides</b> _____	24-29
<b>Slide Beams</b> _____	30-31
<b>'V' Bearings</b> _____ 	32-35
<b>Cap Seals, Cap Wipers and Lubricators</b> _____ 	36-38
<b>Flange Clamps</b> _____ 	39
<b>Flat Tracks</b> _____	40
<b>Track Rollers</b> _____ 	41-43
<b>Racks</b> _____	44
<b>Pinions</b> _____ 	45
<b>Belt Driven Carriages, Belts &amp; Pulleys</b> _____ 	46-47
<b>Rack Driven Carriages</b> _____ 	48-49
<b>Gearboxes, AC Geared Motors &amp; Flanges</b> _____ 	50-51
<b>AC Speed Controller &amp; Ancillary Components</b> _____ 	52-53
<b>Data and Dimensions for Assembled Systems</b>	
<b>'V' Slide Systems</b> _____	54-55
<b>Systems with Track Rollers, Racks &amp; Pinions</b> _____	56-57
<b>Technical Data</b>	
<b>Load/Life Calculations and Examples</b> _____	58-62
<b>Deflection of Self-Supporting Slides</b> _____	63
<b>Drive Calculations for Rack Driven Carriages</b> _____	64-65
<b>System Assembly and Adjustment</b> _____	66-67
<b>Technical Specifications</b> _____	68

## How To Use This Catalogue

The GV3 product range is large, so to help readers find their way around the catalogue, the following aids have been devised:

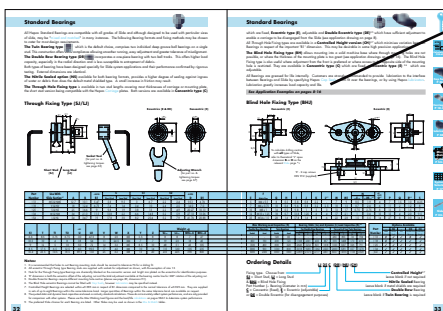

**Cap Seals** ← **Blue 'Hypertext'**

Throughout the catalogue, key words have been picked out in **Blue 'Hypertext'**. Where this appears, look for a **Page Icon** to direct you to other related pages.

**Page Icons**

Page Icons are located on the outside edge of pages in alphabetical order. They include a picture of a component or catalogue section which is related to the subject under discussion, together with a page number. This acts as a quick index.

# System Composition

## Linear Motion System with Standard Bearing Programme

Pages 2-7 provide an overview of the comprehensive GV3 linear motion system. Below is shown the basic range of Slides and components available with Hepco's Standard Twin and Double Row Bearings. A similar range is available with Hepco's

### ALL SLIDES (COMMON FEATURES) [24-29](#)

- One piece construction for assured parallelism and rigidity.
- Manufactured from high quality bearing steel.
- Deep hardened V faces for maximum wear resistance.
- Soft centre section allows customising.
- Wide range of sizes to choose from.
- 3 grades of precision to suit cost/performance requirements.
- Any length supplied up to 4 metres, unground grade to 6 metres.
- Unlimited length achieved by butting.
- Attractive, corrosion inhibiting black finish on unground faces.
- Common 70° 'V' allows many bearing/slide combinations.

### LUBRICATOR [38](#)

- Lubricates contact surfaces increasing load capacity and life.
- Can be attached from either side of a carriage.
- Lightly sprung felt wiper ensures low friction.
- Flanged and Compact versions available.
- Long lubrication interval.

### SINGLE EDGE FLAT SLIDE / DOUBLE EDGE FLAT SLIDE [28-29](#)

- Lower weight for less inertia where Slide is the moving component.
- Lower cost in cases where spacer is part of customer's construction.
- Plain hole, or counterbored fixing option for flush top surface.
- A number of widths for each basic section gives 11 sections to choose from.
- Can be spaced apart for high moment load capacity.

### PINIONS [45](#)

- Bored type and integral shaft type available.
- Hardened teeth for long life.
- Keyway provided in bored type pinion.
- Shaft type pinion compatible with Hepco Rack Driven Carriage.
- Shaft type pinion compatible with Hepco Motor Gearboxes.

### SINGLE EDGE SPACER SLIDE [26-27](#)

- Mounts directly to a flat surface. No spacer required.
- Can be spaced apart for high moment load capacity.
- Keyway and datum edges provide means of location and alignment.
- Counterbored hole fixing, tapped hole fixing or undrilled options available.
- Plastic hole plugs provided to avoid debris traps.
- Rack cut option provides means of driving.
- Back face provides mounting register, or running surface for Track Roller.
- 5 sections to choose from.

### CAP SEAL [36](#)

- Lubricates contact surfaces increasing load capacity and life.
- "Lubricated for life" in most applications.
- Seals against ingress of debris.
- Improves operational safety.
- Enhances appearance of system.
- Incorporates both through hole and tapped hole fixing facility.

### DOUBLE EDGE SPACER SLIDE [24-25](#)

- Mounts directly to a flat surface. No spacer required.
- Keyway and datum edges provide means of location and alignment.
- Counterbored hole fixing, tapped hole fixing or undrilled options available.
- Plastic hole plugs provided to avoid debris traps.
- A number of widths for each basic section gives 11 sections to choose from.

# System Composition

Slimline Bearings, details of which are shown on the following page. Components are available factory assembled where possible or as individual parts if preferred. Many sizes and types of Hepco component can be interchanged to achieve an unrivalled combination of space and performance possibilities.

**The GV3 philosophy is to provide a solution to every linear motion problem.**

## ALL BEARINGS (COMMON FEATURES & OPTIONS) 32-33

- Special raceway conformity and low radial clearance, for Slide applications.
- Twin bearing for tolerance of misalignment and smooth running.
- Double row bearing for tolerance of debris and higher load capacity.
- Range of 5 useful sizes to choose from.
- Metal shields for exclusion of particulates and low friction running.
- Nitrile sealed version prevents ingress of liquids.



### DOWEL PINS 25&27

- Easy method of location and alignment.

### CONCENTRIC BEARING 32-33

- Provides datum reference for the system.
- Short fixing stud for thin carriage plate.
- Long fixing stud for thick carriage plate.
- Controlled height option improves system height accuracy.



### ECCENTRIC BEARING 32-33

- Provides simple means of adjustment via centre hexagon or socket each end.
- Short fixing stud for thin carriage plate.
- Long fixing stud for thick carriage plate.
- Controlled height option improves system height accuracy.



### CARRIAGE / CARRIAGE PLATE 18-21

- Factory adjusted to chosen Slide, or supplied as a kit of parts.
- Available with Bearings only, or with the addition of Cap Seals or Lubricators.
- Useful size platform with flush surface for mounting purposes.
- Tapped holes in convenient positions for attachment purposes.
- Groove along sides to provide register for switch brackets etc.
- Carriages available for all 11 Slide sections in all grades.
- 3 lengths available in each size and most types.
- Tamper proof option.
- Removable option for direct disengagement from Slide.
- Controlled height option for special accuracy requirements.



### DOUBLE ECCENTRIC BEARING 32-33

- Eccentric throw sufficient for direct removal of Carriage from Slide.
- All attributes of the standard Eccentric version apply.



### BLIND HOLE CONCENTRIC BEARING } 32-33

### BLIND HOLE ECCENTRIC BEARING }

- For mounting into thick plates or where access to opposite side restricted.
- Adjustable from operating side for ease of access.



### TWIN BEARING/DOUBLE ROW BEARING 32-33

- Twin bearing for tolerance of misalignment and smooth running.
- Double row bearing for tolerance of debris and higher load capacity.
- Special raceway conformity and low radial clearance, for Slide applications.
- General quality to ISO Class 4. Aspects to Class 2.
- Made in Hepco factory which has the following accreditation: - ISO 9001 Aerospace Sector Certification TS 157



# System Composition

## Linear Motion System with Slimline Bearing Programme

Pages 2-7 provide an overview of the comprehensive GV3 linear motion system. Below is shown the basic range of Slides and components available with Hepco's Slimline Bearings. An identical range of Slides is available with Hepco's Standard Bearings, details of which are shown on the previous page. Components are available factory assembled where possible or

### ALL SLIDES (COMMON FEATURES) [24-29](#)

- All Slides suitable for both Slimline and Standard Bearings. Please see previous page for specific features.
- One piece construction for assured parallelism and rigidity.
- Manufactured from high quality bearing steel.
- Deep hardened V faces for maximum wear resistance.
- Soft centre section allows customising.
- Wide range of sizes to choose from.
- 3 grades of precision to suit cost/performance requirements.
- Any length supplied up to 4 metres, unground grade to 6 metres.
- Unlimited length achieved by butting.
- Attractive, corrosion inhibiting black finish on unground faces.
- Common 70° 'V' allows many bearing/slide combinations.

### LUBRICATOR [38](#)

- Lubricates contact surfaces increasing load capacity and life.
- Lightly sprung felt wiper ensures low friction.
- Can be attached from either side of the carriage/mounting surface.
- Long lubrication interval.

### DOUBLE EDGE FLAT SLIDE [28-29](#)

- Please see previous page for features.

### DOUBLE EDGE SPACER SLIDE [24-25](#)

- Please see previous page for features.

### PINIONS [45](#)

- Bored type and integral shaft type available.
- Hardened teeth for long life.
- Keyway provided in bored type pinion.
- Shaft type pinion compatible with Hepco Rack Driven Carriage.
- Shaft type pinion compatible with Hepco Motor Gearboxes.

### SINGLE EDGE SPACER SLIDE [26-27](#)

- Please see previous page for features.

### SINGLE EDGE FLAT SLIDE [28-29](#)

- Please see previous page for features.

### CAP WIPER [37](#)

- Lubricates contact surfaces increasing load capacity and life.
- "Lubricated for life" in most applications.
- Seals against ingress of debris.
- Improves operational safety.
- Enhances appearance of system.
- Incorporates both through hole and tapped hole fixing facility.

### BLIND HOLE ECCENTRIC BEARING [34-35](#)

- For mounting into thick plates or where access to opposite side is restricted.
- Adjustable from operating side for ease of access.

### BEARING ATTRIBUTES [34-35](#)

- Special raceway conformity and low radial clearance, for Slide applications.
- General quality to ISO Class 4. Aspects to Class 2.
- Made in Hepco factory which has the following accreditation: - ISO 9001  
Aerospace Sector Certification TS 157.

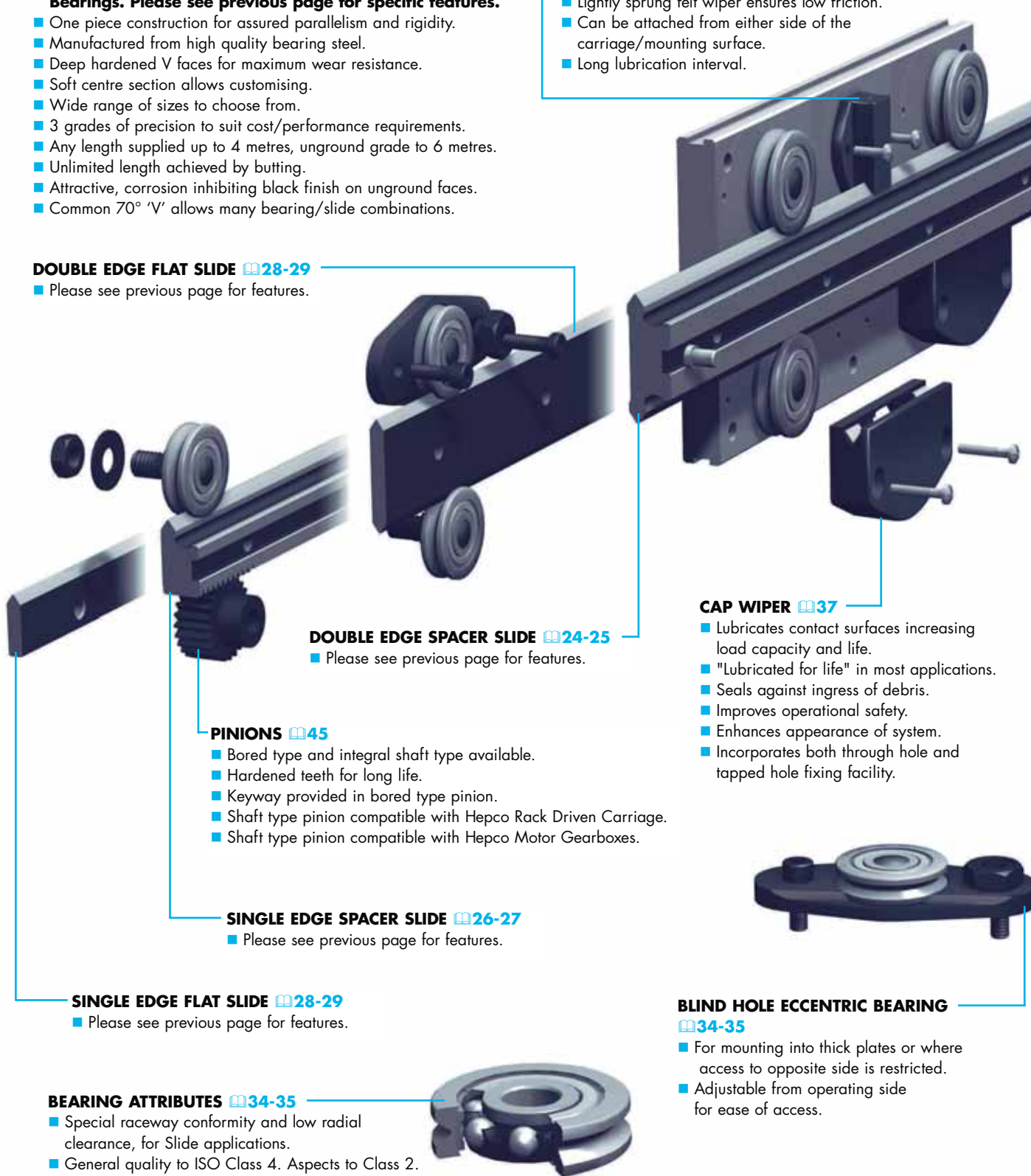

## System Composition

as individual parts if preferred. Many sizes and types of Hepco component can be interchanged to achieve an unrivalled combination of space and performance possibilities.

**The GV3 philosophy is to provide a solution to every linear motion problem.**



### DOWEL PINS [25&27](#)

- Easy method of location and alignment.

### SLIMLINE BEARINGS (COMMON FEATURES & OPTIONS) [34-35](#)

- Special raceway conformity and low radial clearance, for Slide applications.
- Narrow profile for compact system height.
- Low cost system, specially if combined with P3 grade (unground) slides.
- Load capacity adequate for many applications.
- Single piece bearing for tolerance of debris.
- Range of 4 useful sizes to choose from.
- Metal shields for exclusion of particulates and low friction running.
- Nitrile sealed version prevents ingress of liquids.

### ECCENTRIC BEARING [34-35](#)

- Provides simple means of adjustment via centre hexagon.
- Short fixing stud for thin carriage plate.
- Long fixing stud for thick carriage plate.



### CONCENTRIC BEARING [34-35](#)

- Provides datum reference for the system.
- Short fixing stud for thin carriage plate.
- Long fixing stud for thick carriage plate.



### BLIND HOLE CONCENTRIC BEARING [34-35](#)

- For mounting into thick plates or where access to opposite side is restricted.



### FLANGE CLAMP [39](#)

- Enables Slide to become a self supporting beam.
- Two mounting possibilities, face fixing or base fixing.
- Easy removal of Slide and positive relocation.
- Available in long or short type, to support a Slide at one or both ends.

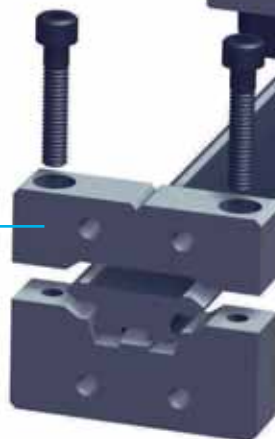

### CARRIAGE / CARRIAGE PLATE [22-23](#)

- Factory adjusted to chosen Slide, or supplied as a kit of parts.
- Available with Bearings only, or with the addition of Cap Wipers or Lubricators.
- Useful size platform with flush surface for mounting components.
- Tapped holes in convenient positions for attachment purposes.
- Groove along sides to provide register for switch brackets, etc.
- Carriages available for most Slide sections in all grades.
- 3 lengths available in each size and most types.
- Tamper proof option.

# System Composition

## Linear Motion System Incorporating Flat Tracks & Rollers

Pages 2-7 provide an overview of the comprehensive GV3 linear motion programme. Below is shown the extensive range of Flat Tracks and Track Rollers compatible with Hepco's linear motion systems. See page 16 for the varied ways in which they can be used.

**The GV3 philosophy is to provide a solution to every linear motion problem.**

### FLAT TRACK 40

- Choose from ground all over, ground on 2 opposing faces, or unground.
- Attractive, corrosion inhibiting black finish on unground faces.
- Deep hardened faces for maximum wear resistance.
- Manufactured from high quality carbon steel.
- Offset fixing holes for versatility of mounting.
- 4 useful sizes compatible with Hepco V Slides.
- Any length supplied up to 4 metres in most sizes.
- Unlimited length achieved by butting.

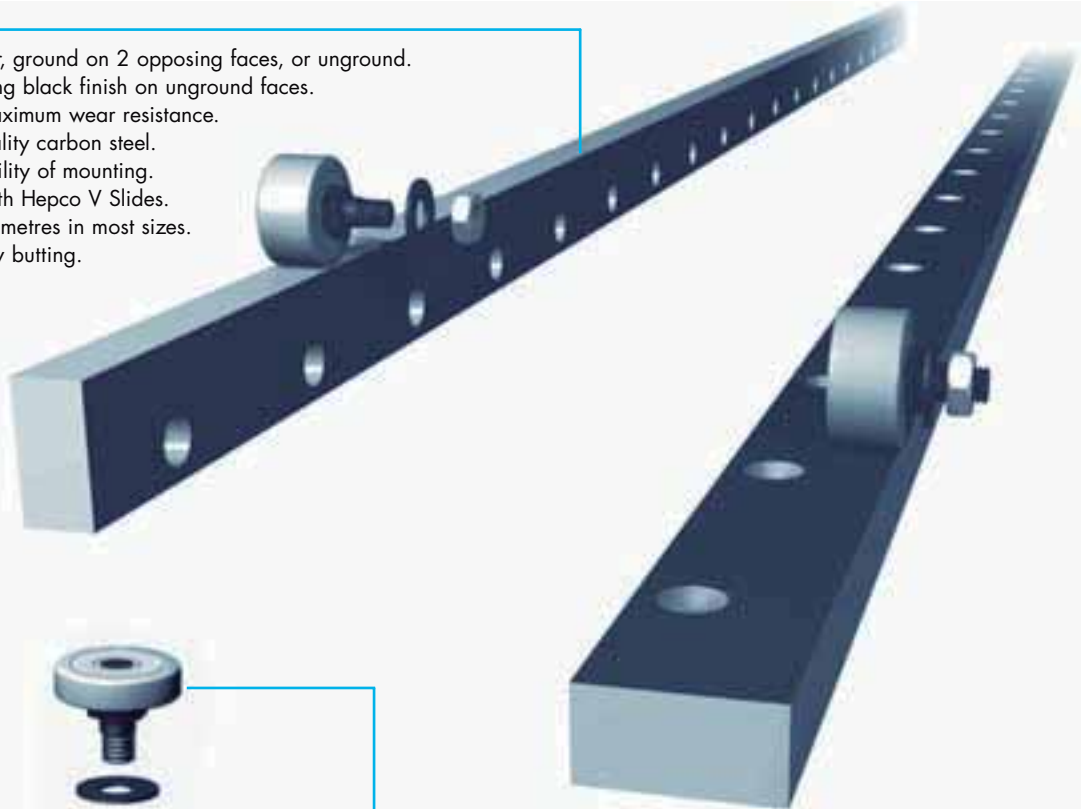

### NARROW TRACK ROLLER (CONCENTRIC) 41

### WIDE ROLLER (CONCENTRIC) 41-43

- Provides datum reference for the system.

### SLIMLINE ROLLER (ECCENTRIC) 41-43

### WIDE ROLLER (ECCENTRIC) 41-43

- Provides simple means of adjustment.

### TRACK ROLLERS (COMMON FEATURES) 41-43

- Size and load capacity equivalent to Hepco V Bearing.
- Special raceway conformity with low radial clearance.
- Range of 4 useful sizes to choose from.
- Crowned running face for tolerance of misalignment.
- Metal shields for exclusion of particulates and low friction running.
- Nitrile sealed version prevents ingress of liquids.
- Designed to run on Track or back face of Single Edge Spacer Slides.
- General quality to ISO Class 4. Aspects to Class 2.
- Made in Hepco factory which has the following accreditation: ISO 9001 - Aerospace Sector Certification TS 157.

### ● BLIND HOLE, WIDE, CONCENTRIC ROLLER 41-43

- ● For mounting into thick plates or where access to opposite side restricted.
- Adjustable from operating side for ease of access.
- Provides datum reference for the system.





# System Composition

## Linear Motion System with Drive Facility / Support Structure

Pages 2-7 provide an overview of the comprehensive GV3 linear motion programme. Below is shown the range of GV3 products available with enhanced features to provide a complete engineering package.

**The GV3 philosophy is to provide a solution to every linear motion problem.**

### BELT DRIVEN CARRIAGE [46-47](#)

- Use with Flat Slides, Spacer Slides or Slide Beams in all grades of precision.
- Choice of 5 sizes each available in two useful lengths.
- Integral belt tensioners for ease of adjustment.
- Removable mounting platform for ease of customising.
- Tapped holes for convenience of attaching components.
- Available with most Hepco Standard Bearing variants and Lubrication devices.

### TIMING PULLEYS [46-47](#)

- Low backlash profile for high positional accuracy.
- Width to suit Belt Driven Carriages.
- Diameter enables belt return through Slide Beam.

### TIMING BELT [46-47](#)

- High strength, steel reinforced AT profile open length belt.
- Cut to length, up to 50 m.
- Widths to suit Hepco Belt Driven Carriages & Pulleys.

### SLIDE BEAMS [30-31](#)

- Can be used as machine construction member.
- Strong section, spans wide gaps.
- Available up to 8 metres in one piece.
- Choice of 2 beam sections and 5 Slide widths.
- Slides available in 3 grades of precision.
- Lightweight version available.
- Counterbored Slide version for belt support.
- Hollow centre for belt, cable or chain return.
- T slots for attaching components.
- Plastic T slot covers, T nuts and fixing clamps available.

### SEPARATE RACK [44](#)

- As used in Rack-Slide assembly.
- 4 sizes available.
- Lengths up to 1.83 m, longer lengths achievable by butting.

### PINIONS [45](#)

- Please see previous page for features.

### RACK DRIVEN CARRIAGE UNIT [48-49](#)

- Carriage includes drive pinion & AC geared motor or gearbox.
- Carriages available to suit 7 rack-slide sizes.
- Size, shape, and drive position bespoke to your requirements.
- Carriages available with all Standard Bearing types and Lubrication devices.
- Fine adjustment facility for pinion assures low backlash.
- Gearbox, Flange, Pinions & Motor are available separately for use in your own design, or with rack cut single edge slides or separate racks.

### RACK-SLIDE ASSEMBLY [24-25](#)

- Dowelled Rack-Slide assembly is ready to fix to your mounting surface.
- Available in 10 useful sizes and 3 grades of precision for Slide.
- Slides with compound racks available up to 4 metres, unground slide grade to 6 metres.
- Unlimited Rack-Slide length achieved by butting.
- Attractive, corrosion inhibiting black finish on unground Slide faces and on Rack.

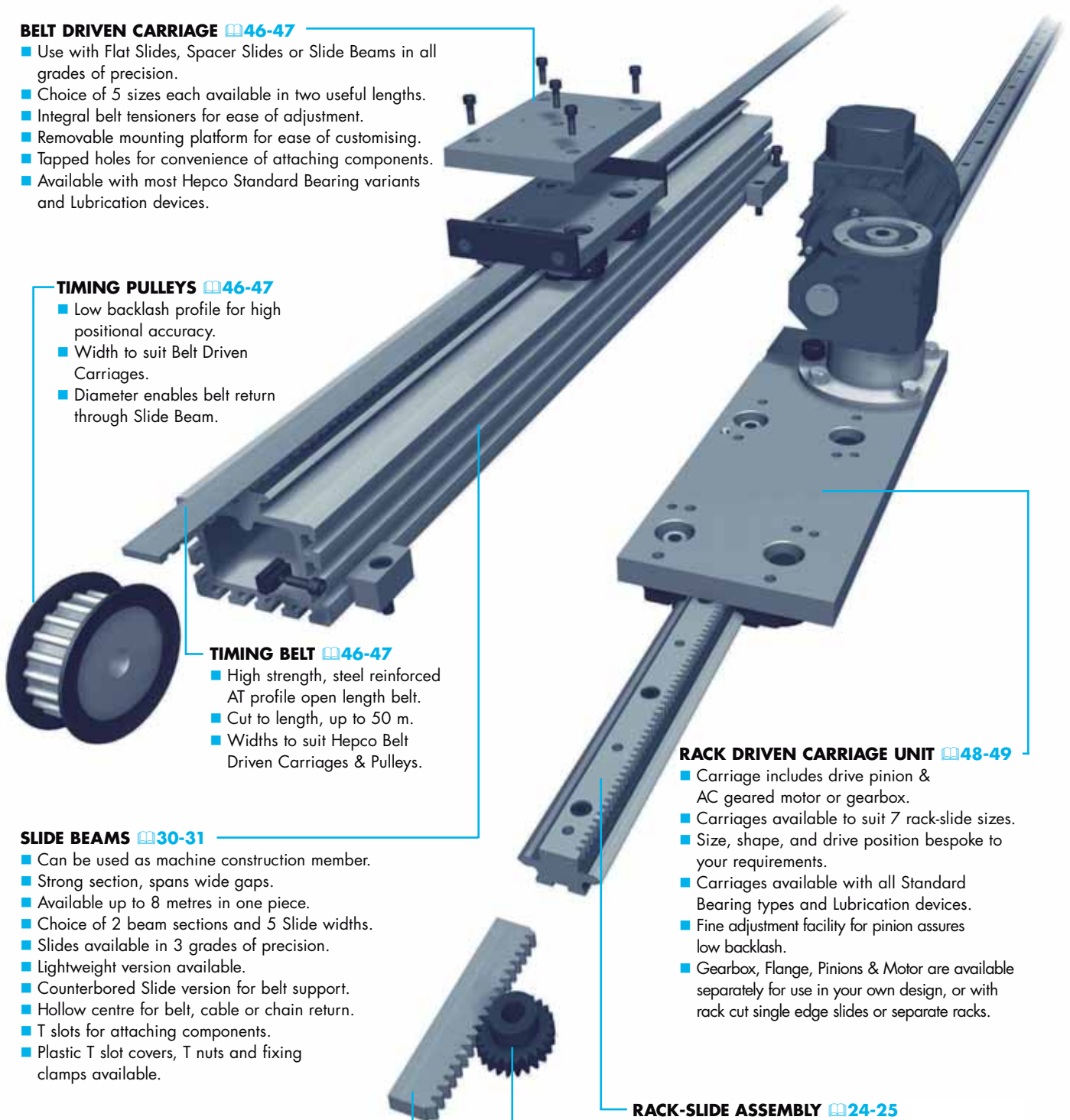

## Application Examples

### Fixing Slides to Tubular Framework

Hepco Single Edge Flat Slides have been designed to attach to the edges of many sizes of square or rectangular tube with sufficient protrusion of the Slide V running face to provide clearance for Hepco Bearings and Lubrication Devices. The fixing hole positions have been regulated to clear the external corner radius of the tube and to allow attachment by means of standard sizes of hexagon bar. Alternatively, Slides can be attached by "Flowdrilling" or by welding.

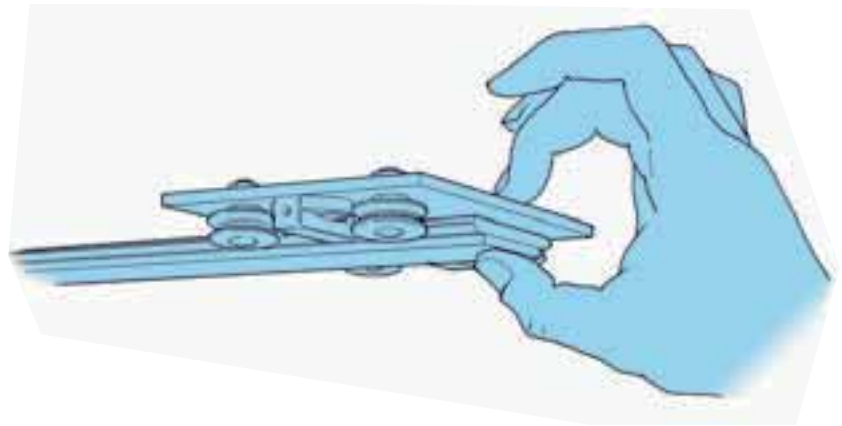
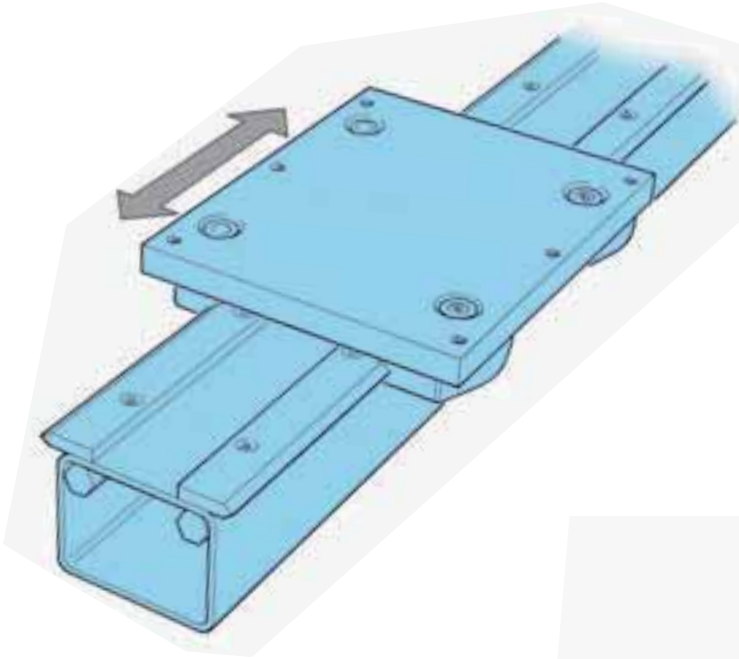

### Low Height System

A very compact slide system can be achieved by using Hepco Flat Slides in conjunction with Slimline Bearings and by choosing thin section material for the carriage and slide support.

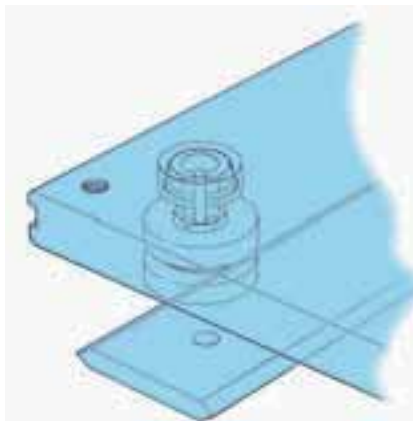

### Tamper Proof Carriage

Hepco Carriages can be supplied "Tamper-proof" by pinning the Bearing studs once they have been factory adjusted to the Slide. After pinning, the counterbores are filled with resin.

### Removable Carriage

This example shows how a Carriage incorporating Double Eccentric type Bearings can be taken off a Slide in any position without running the Carriage off the end. This facility saves having to dismantle part of the machine in cases where the ends of the Slide are "blocked".

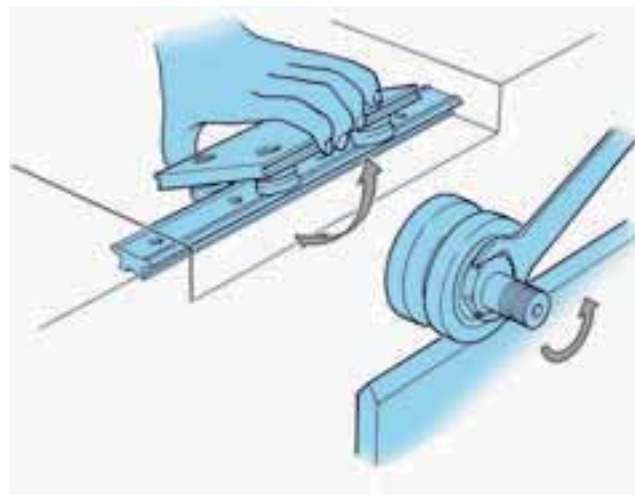

## Application Examples

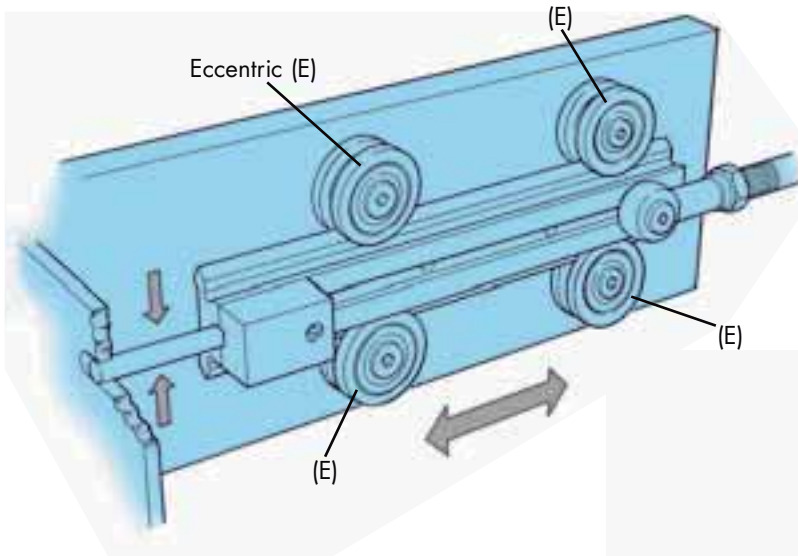

### Light Applications

Where very light loads are anticipated, three Bearings may be used instead of the usual configuration of four. This saves on component cost and assembly time.

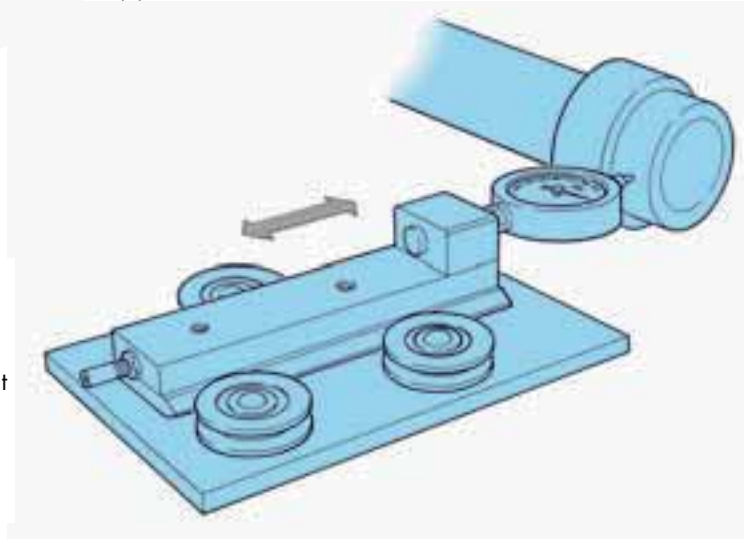

### Ease of Alignment using all Eccentric Bearings

Example shows the possibility to adjust the Hepco GV3 slide system in one plane, thus avoiding the necessity for precision drilling and fitting.

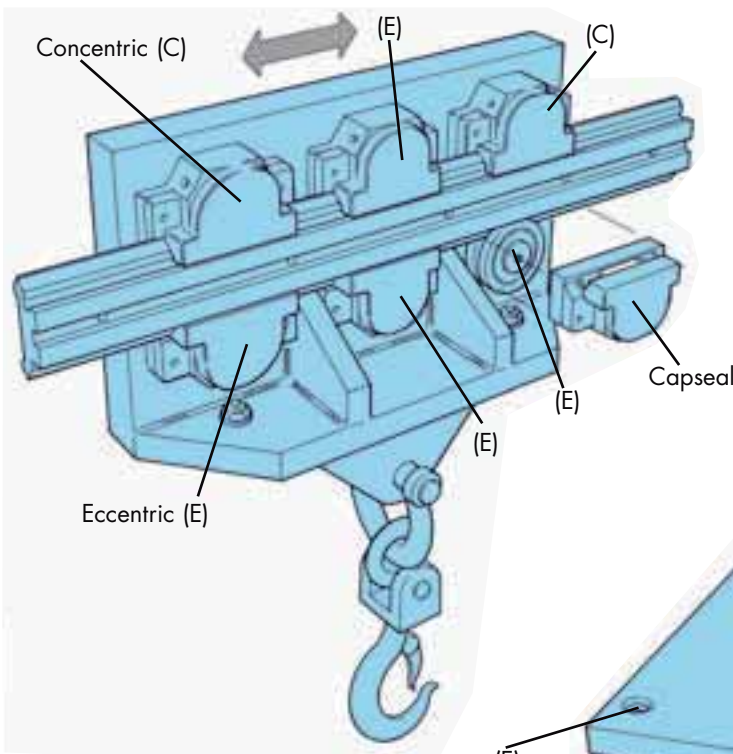

### Heavy Load Requirements

For increased load capacity, additional Eccentric Bearings may be installed in between the outermost ones. Multiple bearing installations benefit from the use of Controlled Height Bearings which ensure better load distribution. Cap Seals will also maximise load capacity (see load/life section). Please consult Hepco's Heavy Duty Slide System catalogue where very high loads are anticipated.

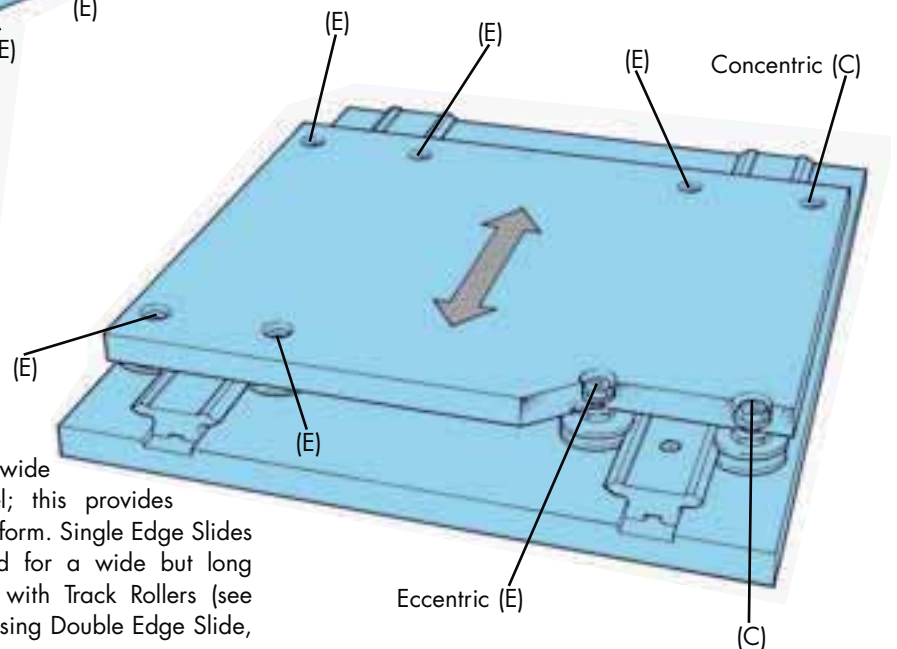

### Wide Platform

Rigidity is achieved at the extremities of a wide platform by mounting slides in parallel; this provides maximum support for a wide but short platform. Single Edge Slides (see pages 26-27) should be considered for a wide but long platform. Alternatively, Hepco Flat Track with Track Rollers (see pages 41-43) in conjunction with an opposing Double Edge Slide, will obviate the need to set slides parallel.

## Application Examples

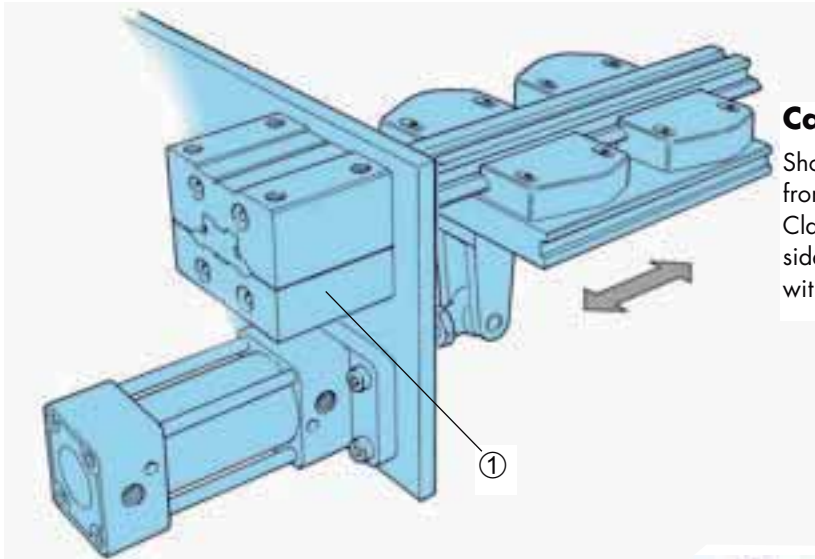

### Cantilevered Linear Guide

Short stroke sliding movements may be supported from one end only, using long series Hepco Flange Clamps ①. Flange Clamps may be bolted to either side of the supporting framework and are available with either through holes or tapped holes.

### Simple Two Axis Connection

Hepco short series Flange Clamps ① are an ideal method of connecting opposing Carriages and creating a second axis which can be easily installed or removed. Care should be taken to ensure parallelism between slides. Using Hepco Flat Track and Track rollers in place of one of the slides will overcome necessity to set parallel (see page 16).

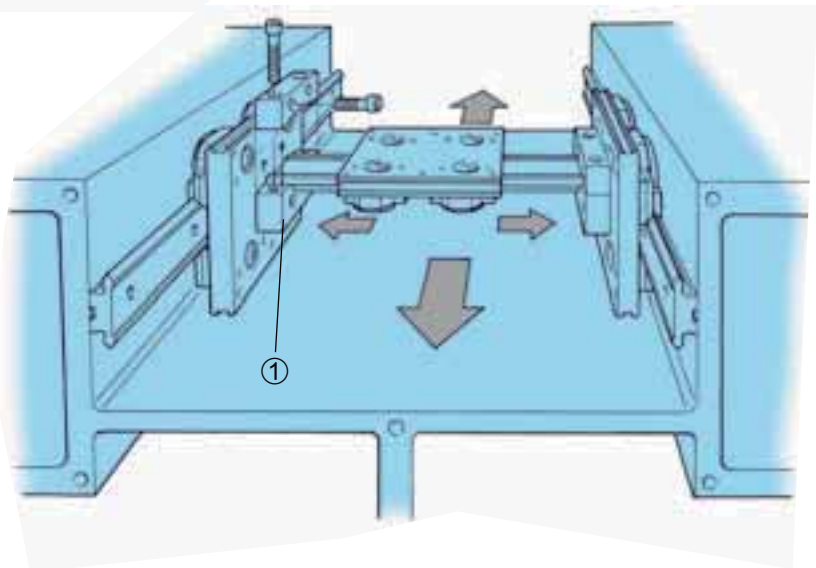

### Multi-Lane Row Divider

Hepco Flange Clamps ① can be used to support a Double Edge Spacer Slide ② in a number of positions by utilising the base mounting facility. No oil is permitted in this example so Bearings ③ are used without Cap Seals or Lubricators. The GV3 system is well suited to run "dry", especially in lighter duty applications.

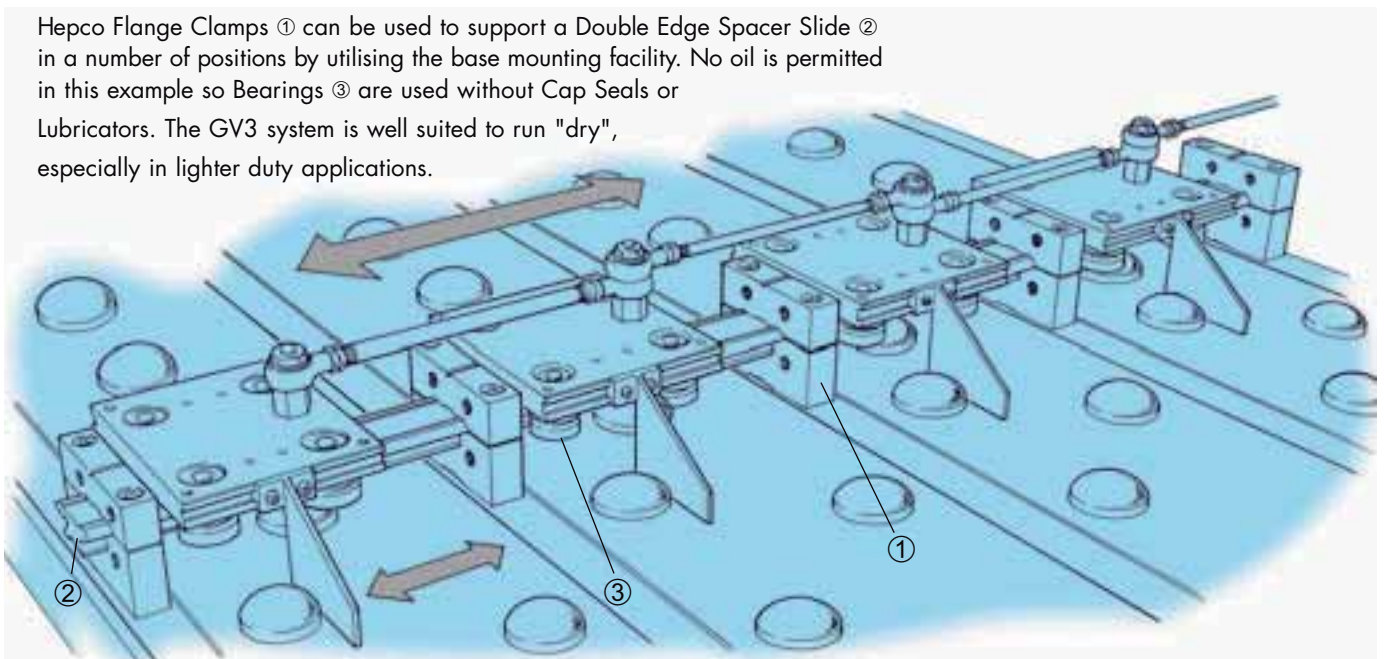

## Application Examples

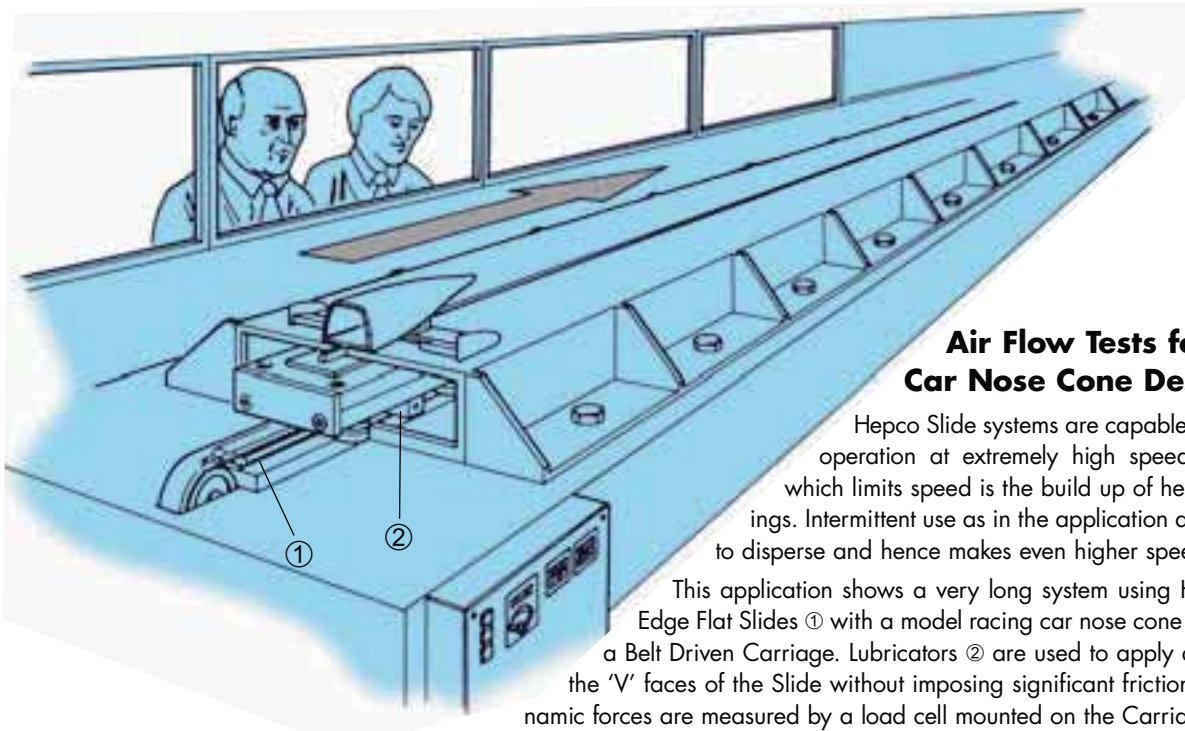

### Air Flow Tests for Racing Car Nose Cone Design

Hepco Slide systems are capable of continuous operation at extremely high speeds. The factor which limits speed is the build up of heat in the bearings. Intermittent use as in the application allows the heat to disperse and hence makes even higher speeds possible.

This application shows a very long system using Hepco Double Edge Flat Slides ① with a model racing car nose cone mounted onto a Belt Driven Carriage. Lubricators ② are used to apply a film of oil to the 'V' faces of the Slide without imposing significant friction. The aerodynamic forces are measured by a load cell mounted on the Carriage.

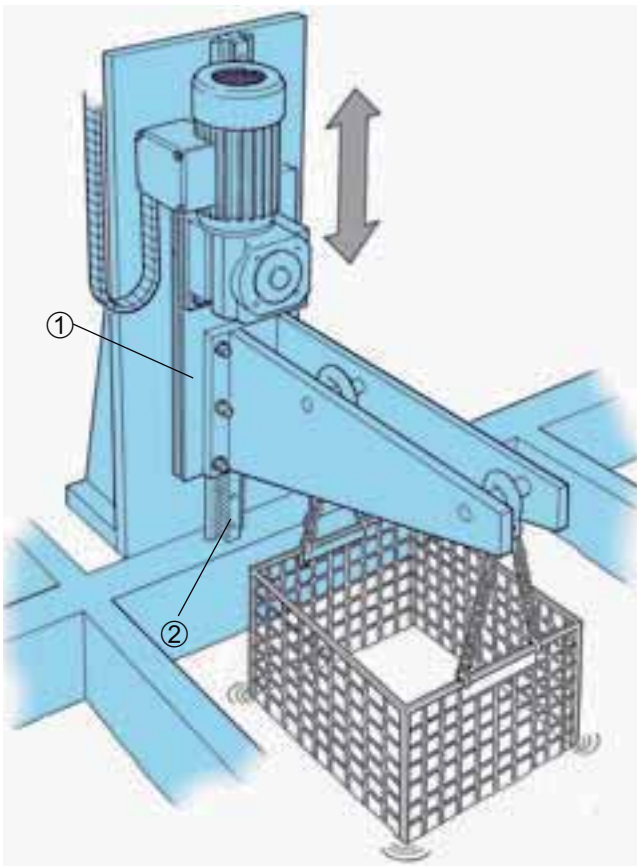

### Dipping System for Plating Vat

A basket of parts is lowered into vat by means of Rack Driven Carriage ① and Rack Mounted Slide ②, available from Hepco as a complete unit. System includes AC motor gearbox and pinion with micro adjustment for correct tooth engagement. The system is able to withstand high transmission forces and provides a low cost reliable solution capable of working in a hostile environment.

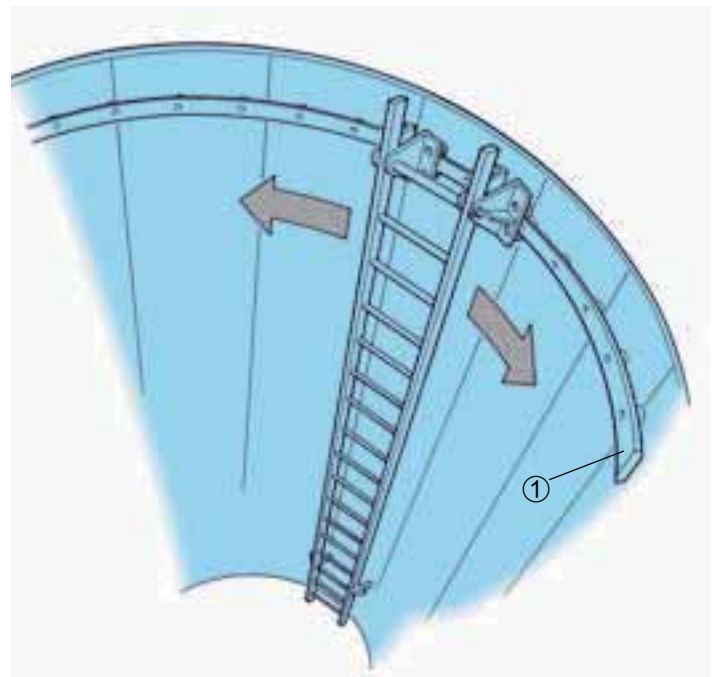

### Rolled Slide for Curved Applications

Hepco Flat Sides ① can be rolled to any diameter above 500 mm depending on section and whether hardened or not (unhardened slides available to special order). Also, Slides in unrolled condition may be bolted to a gently curved surface. Bearing mounting faces on the carriage should be machined so that each pair of Bearings is perpendicular to the slide. Please contact Hepco for application advice.

## Application Examples

### Remote Controlled Camera

Hepco Slides are used extensively in theatre and filming for positioning cameras or lighting. This example shows a Hepco Slide Beam ① with flush Slide surface for engagement with a friction drive roller. The Slide Beam which is attached to the ceiling members, provides a rigid foundation and absorbs vibration.

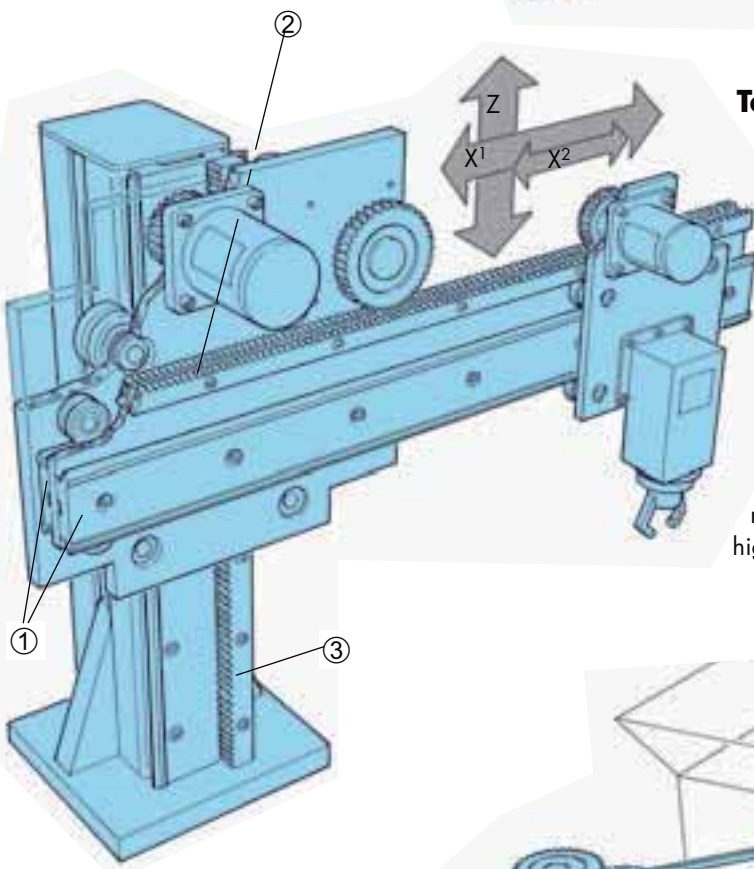
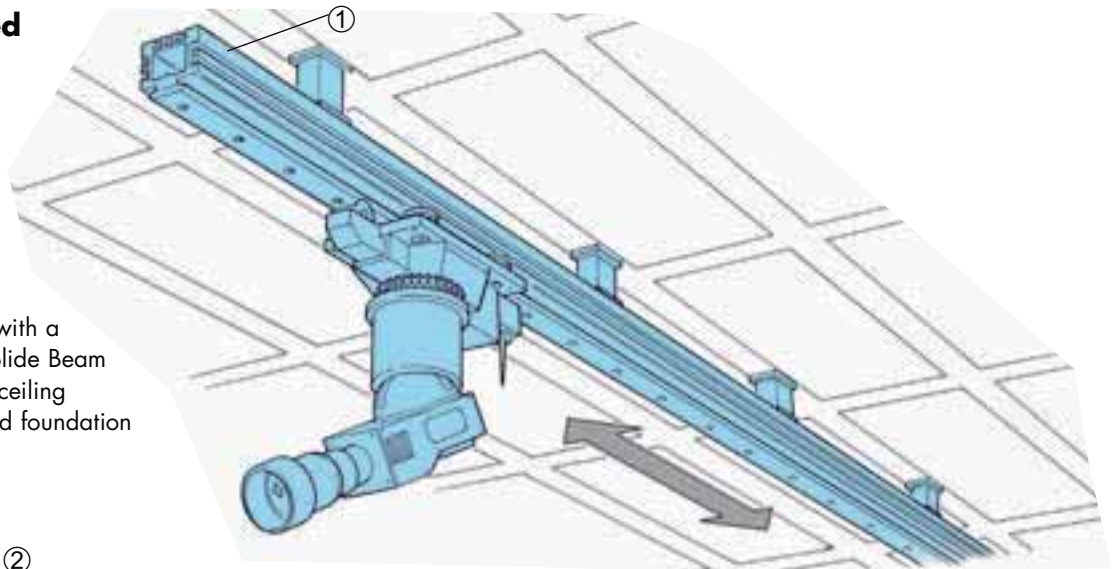

### Telescopic Pick and Place Gantry

The beam retracts out of the paths of adjacent production lines, enabling components to be moved from one line to another without interrupting flow.

**Primary X axis:** Double Edge Spacer Slides ① are mounted back to back, sandwiching the support plate for the Hepco Racks ②, providing a compact design and a rigid beam.

**Secondary X axis:** The gripper mechanism is driven end-to-end along the beam by motor and Pinion engaged in the secondary Rack.

**Z axis:** A Hepco 120 mm wide Spacer Slide with rack ③ is chosen for the vertical axis to withstand the high moment forces involved.

### Pulverising Machine

Hepco Slide Beams ① complete with Belt Driven Carriages ② enable a simple contra-reciprocating motion to be achieved. The high stiffness of the Slide Beams contribute to the rigidity of the structure and absorb vibration. The unique belt tensioning device within the Carriage enables easy adjustment and positioning of the pulverising combs. Hepco Cap Seals ③ ensure long life without further re-lubrication in this application and prevent debris entering the Bearings.

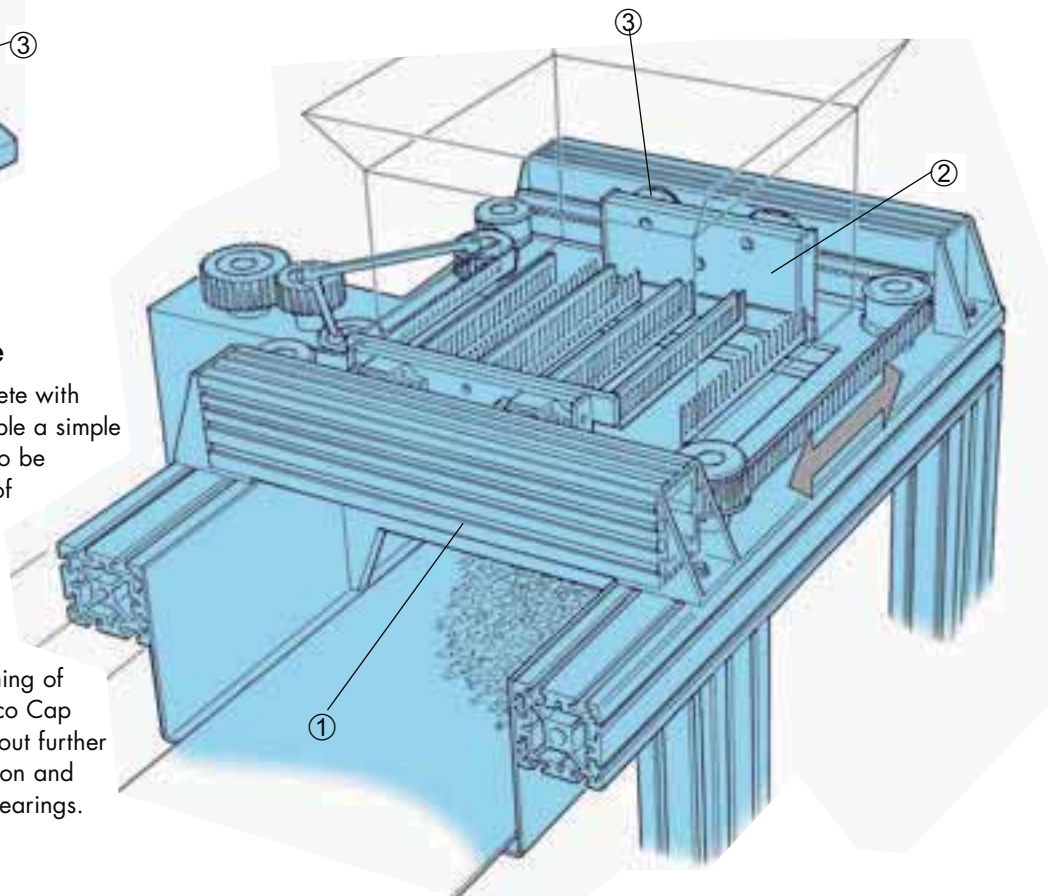

# Application Examples

## High Speed Marking Machine

**X axis:** The Hepco Double Edge Spacer Slide with rack ①, assures parallelism between teeth and 'V' faces of the Slide, providing smooth motion with low backlash. Slides are attached to proprietary frame building systems using Hepco T section location strip ② (send for information sheet No. GV3101).

**Y axis:** Hepco Single Edge Spacer Slides are mounted wide apart for increased stiffness. The lower rack cut slide ③ enables direct drive via Hepco Pinion.

Double Row Bearings for high radial loads and Cap Seals ④ to provide lubrication for long life, are used in this high speed application.

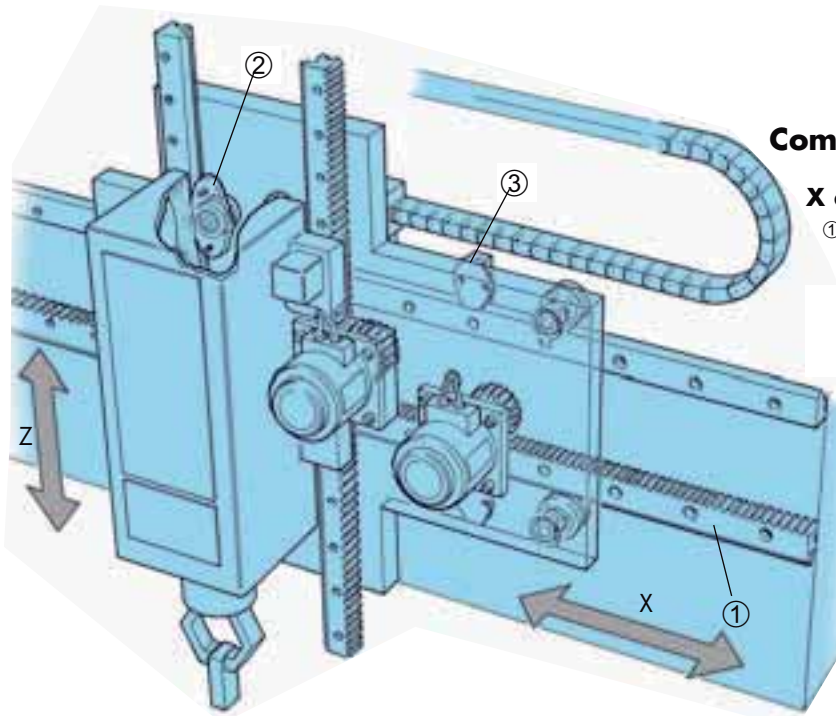
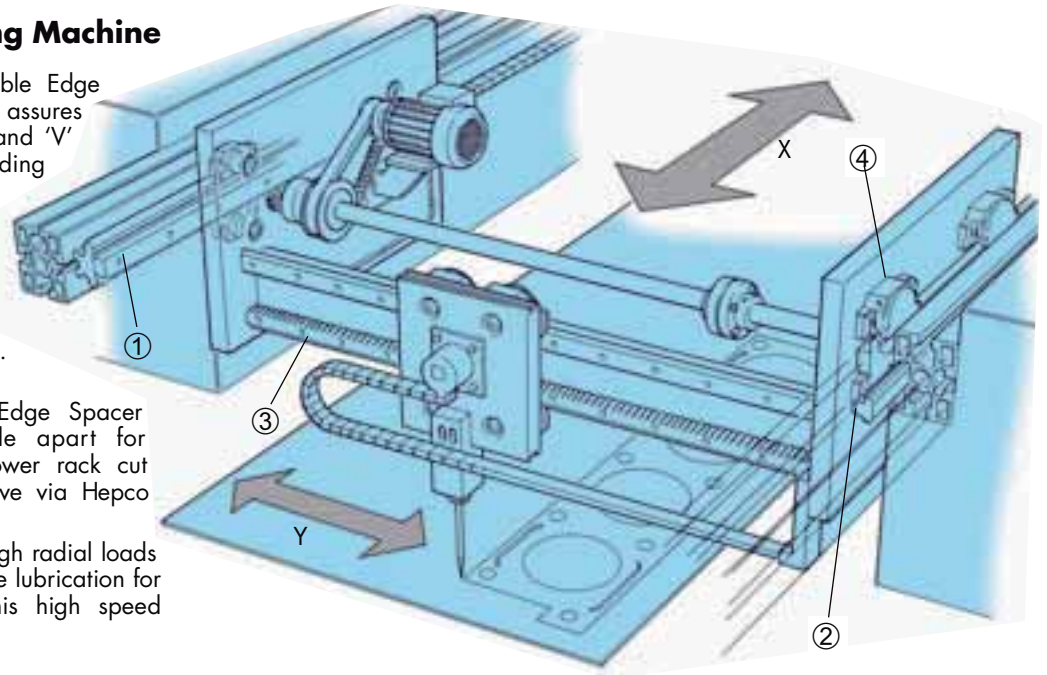

## Compact Rack Driven X-Z Movement

**X axis:** Outward facing Single Edge Spacer Slides ① are mounted sufficiently far apart to provide the required rigidity and to accommodate the drive Pinion. A compact design is achieved by mounting the Bearings on a common plate which also supports the Slides for the Z axis.

**Z axis:** Inward facing Single Edge Spacer Slides allow the motor and drive Pinion to be accommodated adjacent to the gripper housing. Blind Hole Fixing Bearings ② are used as through hole fixing is not possible.

Lubricators ③ are used throughout, for friction free application of oil to minimise risk of stalling the stepper motors.

## Telescopic Loader

Hepco Flat Slides ① combined with Slimline Bearings ② produce a low profile slide system enabling a compact telescopic system to be designed. Hepco Racks ③ are easily incorporated to provide an efficient means of driving via pinions of suitable ratio.

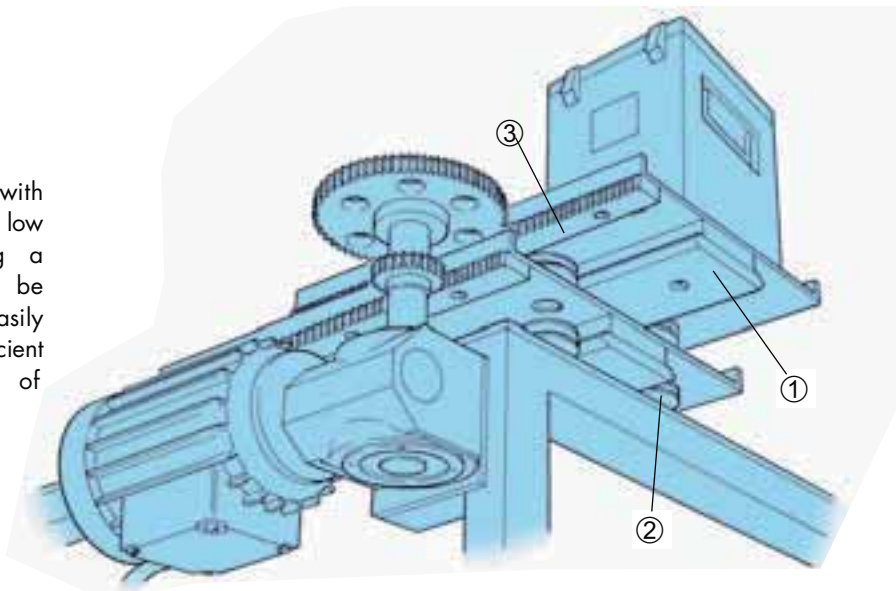

## Application Examples

### Multi Station Product Picking and Collating System

**X axis:** Hepco Single Edge Flat Slides ① bolt direct to machine frame to achieve a simple low cost design. Hepco Bearings are fixed to the carriage structure which spans the collation conveyor and provides room for the drive. Lubrication is not permitted, therefore three Bearings are fitted each side to compensate for reduced load associated with dry running.

**Y axis:** Guidance for the product picking device is provided by Hepco Double Edge Spacer Slide with Fitted Rack ② to enable drive via Hepco Pinion. The Slide runs in a "railway" of Controlled Height, Twin Type Bearings ③ which ensure alignment and compliance as the slide engages. All Eccentric Bearings are used except the two innermost on one side, which are concentric to provide the datum.

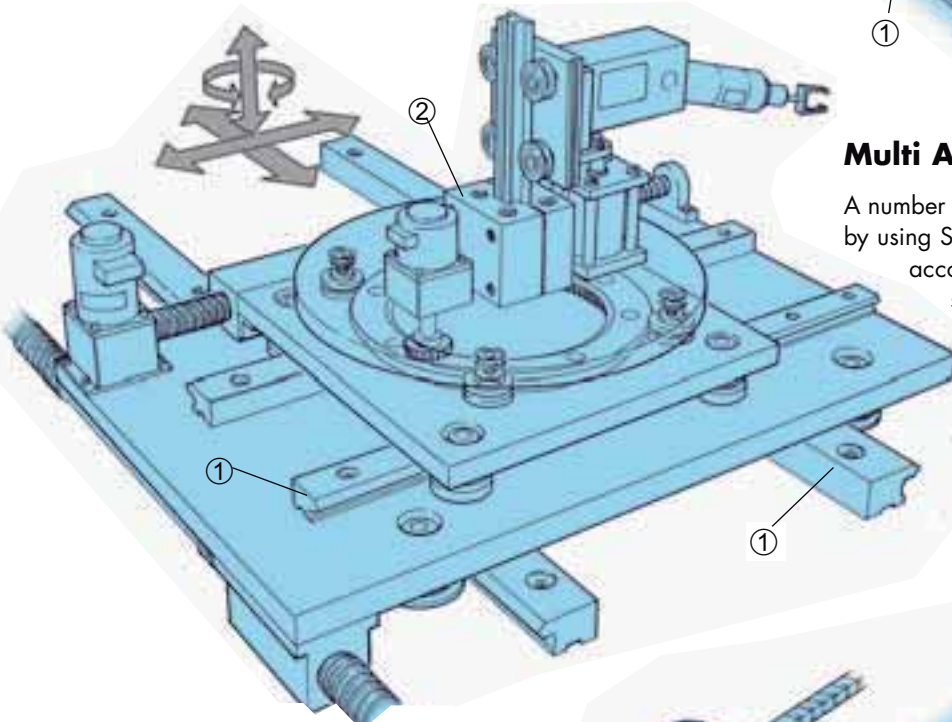
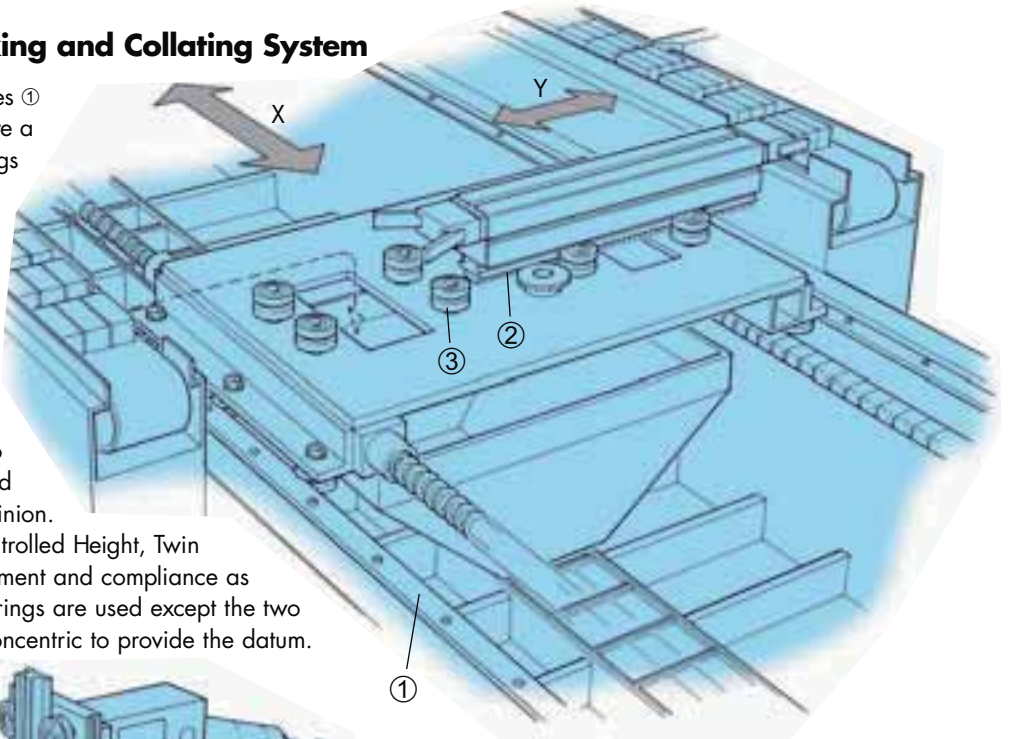

### Multi Axis Robotic Arm

A number of axes can be built up in a compact manner by using Single Edge Spacer Slides ① spaced apart to accommodate platforms sufficiently large to support the adjacent axis. The rotary turntable is also easy to construct by using components selected from Hepco's Ring Slide and Track System catalogue.

The vertical axis supporting the robotic arm is fixed to the rotary table by Hepco long series Flange Clamp ②.

### Cereal Bar Collator

**X Axis:** Hepco Spacer Slides attach to most makes of frame building system by means of Hepco T section location strip ① (send for application sheet No. GV3101 and for Hepco's own MCS Machine Construction System catalogue).

Hepco Belt Driven Carriages ② incorporate an easy means of tensioning as well as providing support for the Y axis.

**Y axis:** Comprises a Hepco DLS unit ③ which is a complete linear motion element with pulleys, switch components and motor-gearbox, if required. Please send for the DLS catalogue.

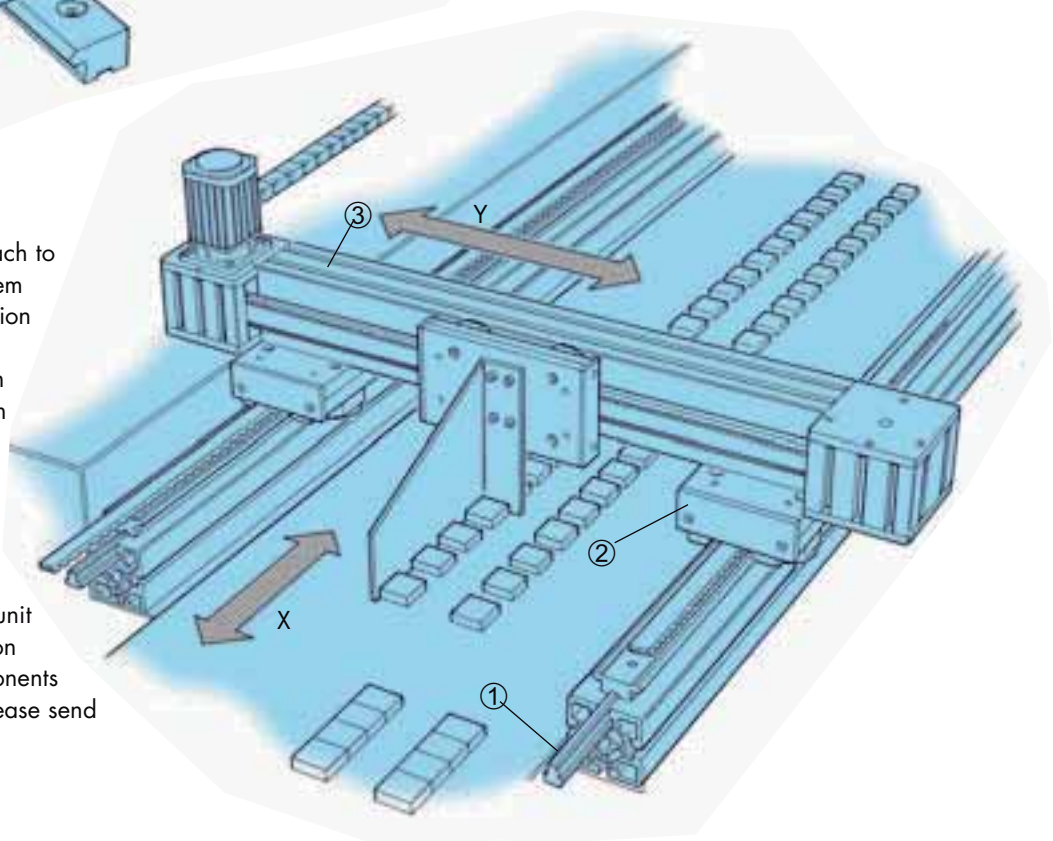



## Application Examples

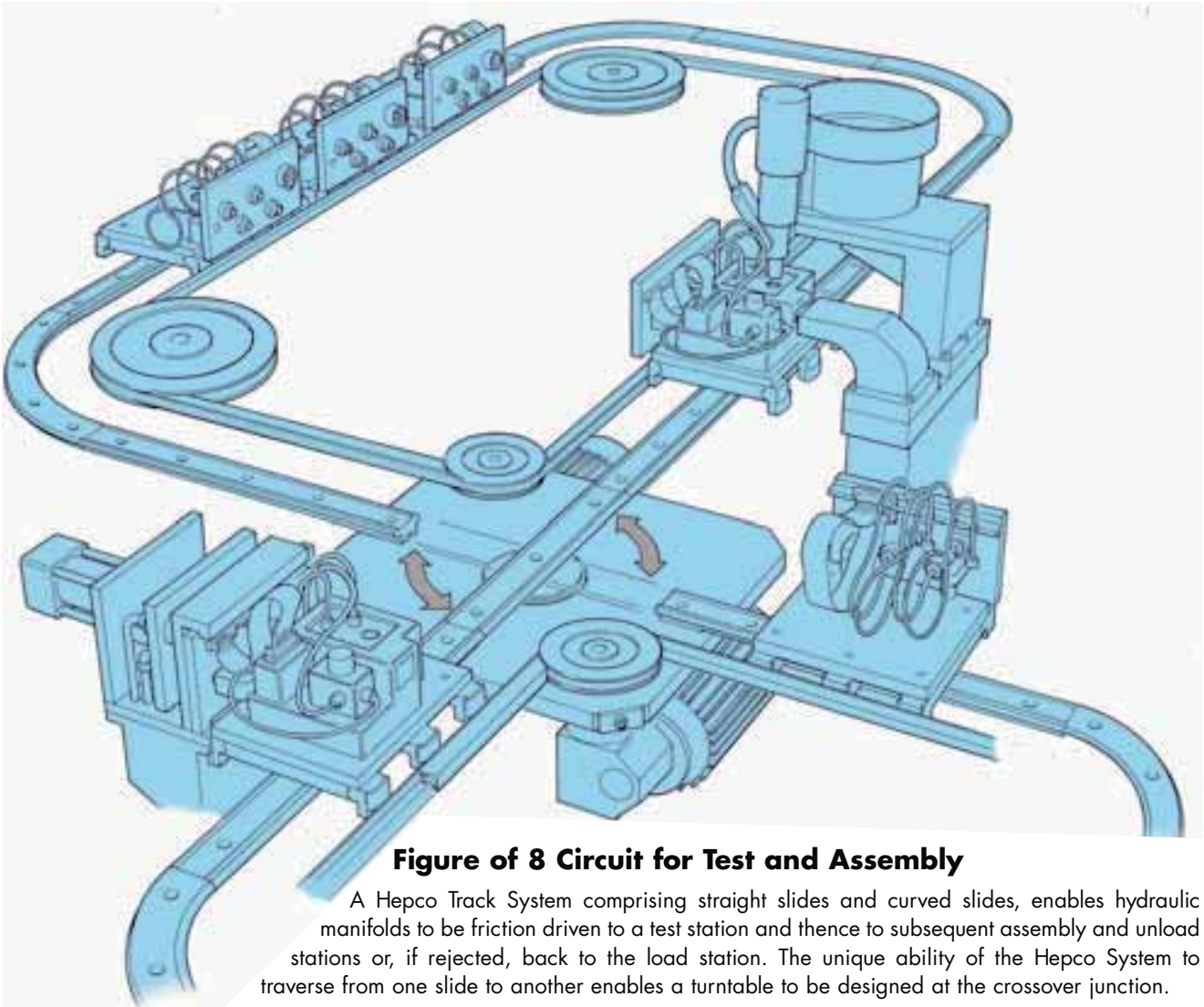

**Figure of 8 Circuit for Test and Assembly**

A Hepco Track System comprising straight slides and curved slides, enables hydraulic manifolds to be friction driven to a test station and thence to subsequent assembly and unload stations or, if rejected, back to the load station. The unique ability of the Hepco System to traverse from one slide to another enables a turntable to be designed at the crossover junction.

Hepco's comprehensive Ring Slides and Track System catalogue is available for customers wishing to construct "railway" type circuits.

### Transport System

A unique feature of the Hepco GV3 system is the ability of a slide to be moved into near perfect alignment with another slide for smooth transfer of carriages. It is therefore possible to switch lanes and change direction. The example shows carriages being driven by friction belt onto a slide which is then elevated to another level. Carriages are cycled around the system, maintaining the same orientation. Customers requiring high speed operation with orientation in the direction of travel, should consult Hepco's Ring Slides and Track System catalogue.

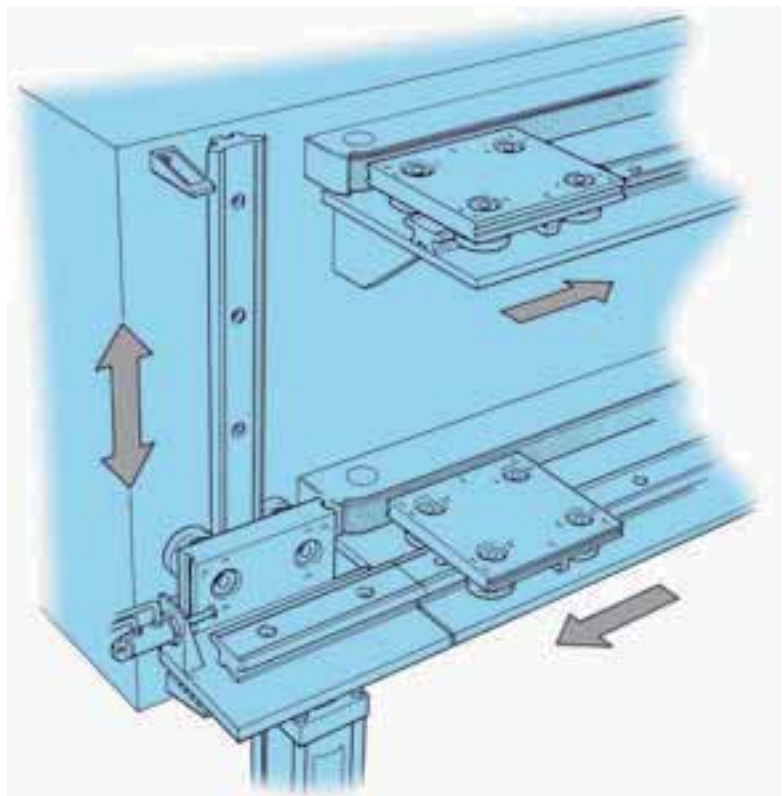

# Application Examples

## Flat Track and Track Roller Applications

The examples below, demonstrate the many and versatile ways Hepco Flat Track and Track Rollers can be used in a linear system. They are especially useful as the opposing element in a system where two guides are mounted apart. This overcomes the necessity to set parallel in both planes, as would be required for two opposing V slides.

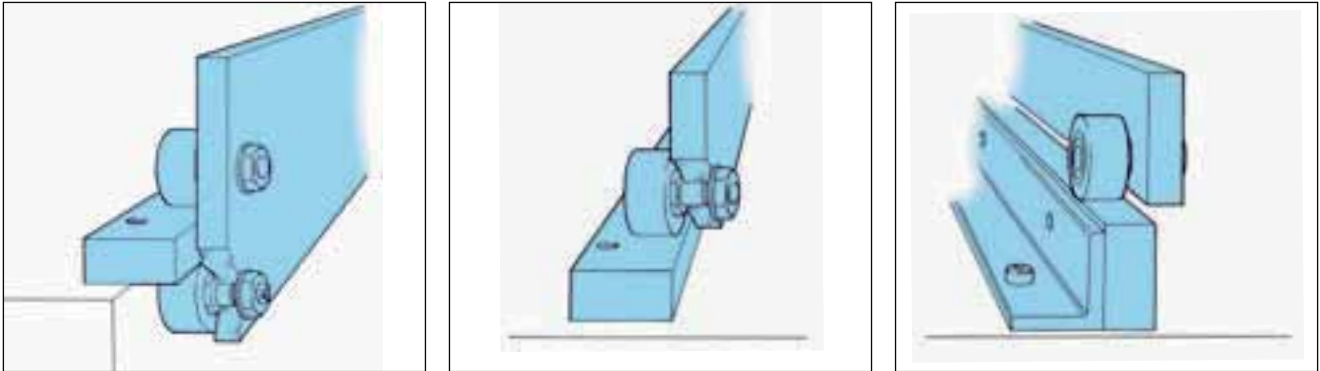

**Bearings & Rollers Fixed,  
Slide Moving**

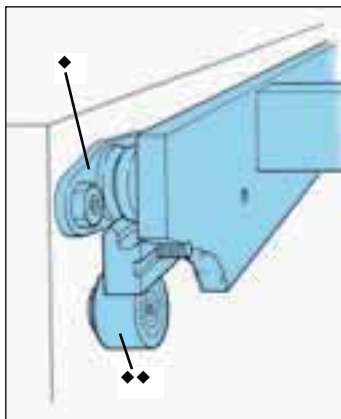

◆ Blind Hole Fixing Standard Bearing (Eccentric)  
◆◆ Blind Hole Fixing Wide Roller (Concentric)

**Bearings & Rollers Moving,  
Slide & Track Fixed**

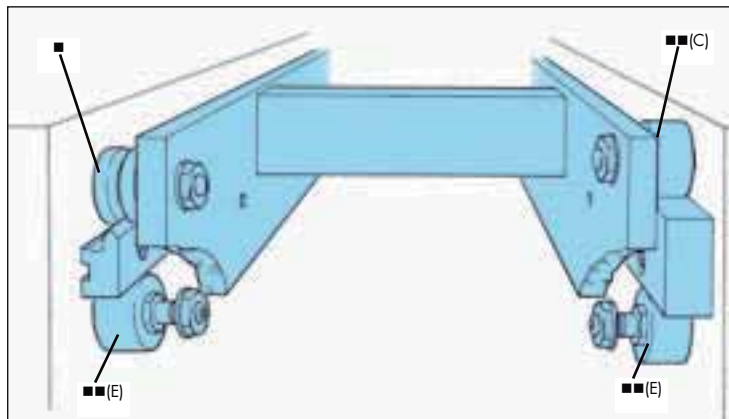

■ Through Hole Fixing Standard Bearing (Concentric)  
■ Through Hole Fixing Wide Roller (Concentric 'C' & Eccentric 'E')

**Rollers Fixed,  
Track Moving**

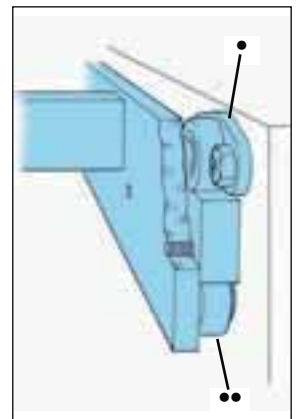

● Blind Hole Fixing Wide Roller  
● Eccentric ● Concentric

**Slimline Bearings & Rollers Moving, Slide & Track Fixed**

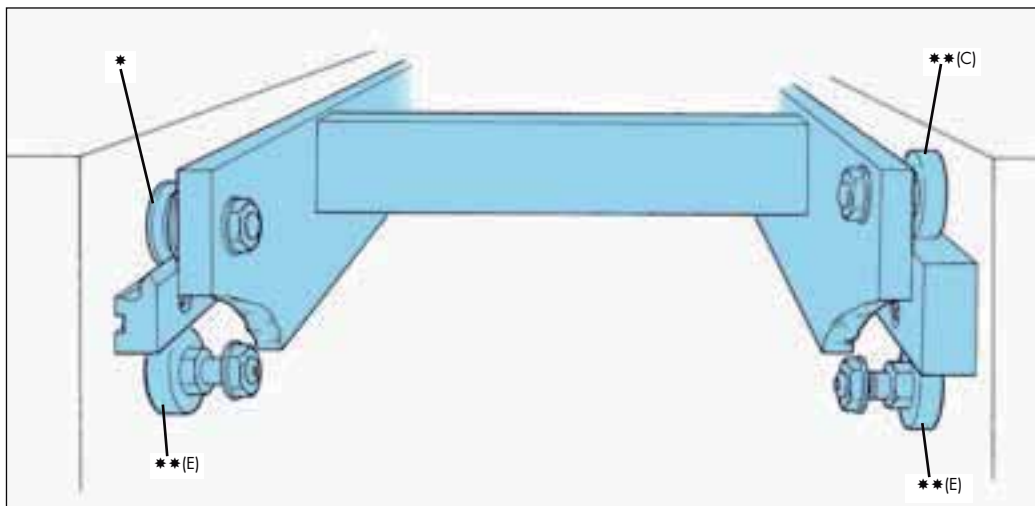





\* Through Hole Fixing Slimline Bearing (Concentric)  
\*\* Narrow Track Roller (Concentric 'C' & Eccentric 'E')



# System Selector

The customer has a wide choice of Hepco GV3 components in order to satisfy most linear motion requirements. To facilitate the selection process, the most commonly used components for a basic slide system have been tabulated to show comparative benefits when used within a complete system.

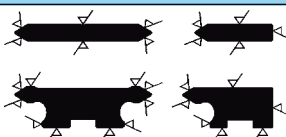
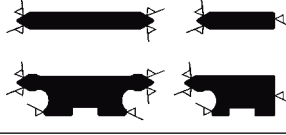
The benefits in the table are the important ones which can be shown in comparative form and are by no means exhaustive. Please see the system composition section (pages 2-7) and pages relating to the individual components for other features, benefits and variants.

Bearing Type	Load	Speed	Smoothness	Tolerance of Misalignment	Rigidity	System Height	Tolerance of Debris	Price
 Standard Pattern Twin Type								
 Standard Pattern Double Row Type								
 Slimline Pattern								

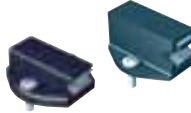
Slide Precision Grade	General Accuracy	Smoothness / Quietness	Friction	Price
<b>P1</b> 				
<b>P2</b> 				
<b>P3</b> 				

Lubrication Method	Load	Lubrication Interval	Debris Exclusion	Friction	Safety & Appearance	Price
<b>None</b>						
 Lubricators						
 Cap Seals or Cap Wipers						

\*The Hepco 'V' bearing principle has a natural wiping action which tends to expel debris.

The above information is a general guide intended for preliminary selection purposes only.

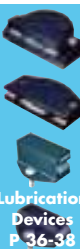

# Standard Carriages



Hepco Standard Carriages are available to suit all sizes and types of Double Edge [Slide](#) in all grades of precision. Each Carriage comes complete with 4 Standard [Bearings](#) and is available in 3 useful lengths to cater for customers' component size and offset load requirements. The Carriage Plates are fully machined from aluminium alloy and are supplied anodised. Tapped holes are provided in convenient positions to enable components to be attached.

Carriages may be specified as **Assembled Units (AU type)** which are factory assembled and set to the [Slide](#). Alternatively, the carriage may be specified as a **kit of components (K type)** for customers wishing to carry out their own assembly.

The following types or options of [Bearing](#) and lubrication device may be specified (refer also to availability table below right).

**The Twin Bearing type** which is the default choice, comprises two individual bearings on a common stud. This offers some compliance, with smoother running, easy adjustment and greater tolerance of misalignment.

**The Double Row Bearing type (DR)** incorporates a one piece bearing with two ball tracks. This offers higher load capacity, especially in the radial direction and is less susceptible to entrapment of debris.

**See Application Examples on pages 10 & 15**

## Example: Short Carriage with Lubricators on a Flat Slide

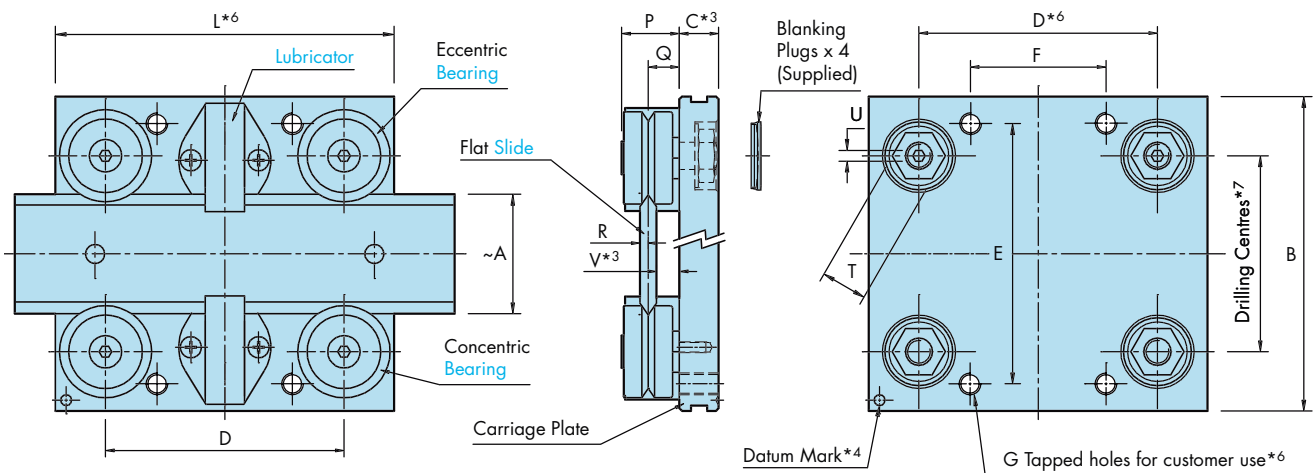

Part Number	For Use With Slides	Bearing Ø	A ~	B	C	D*6			E	F*6			G*6 No of Holes x Thread			H	J*2	
						35	60	85		17	25	50	4 x M4	4 x M4	4 x M4		P1	P2 & P3
AU 12P1/P2 13...	MS 12 & NMS 12	13	12	40	7.34	35	60	85	30	17	25	50	4 x M4	4 x M4	4 x M4	-	19	19.2
AU 12P3 13...	MS 12 & NMS 12	13	12	40	7.34	35	60	85	30	17	25	50	4 x M4	4 x M4	4 x M4	-	19	19.2
AU 20 18...	V 20 & NV 20	18	20	64	10	43	55	95	50	20	44	62	4 x M5	6 x M5	6 x M5	57	24.75	24.95
AU 28 18...	V 28 & NV 28	18	28	72	11	52	80	130	58	25	55	80	4 x M5	6 x M5	6 x M5	65	25.75	25.95
AU 25 25...	S 25 & NS 25	25	25	80	11.5	51	74	120	65	24	60	82	4 x M6	6 x M6	6 x M6	78.5	30.5	30.7
AU 35 25...	S 35 & NS 35	25	35	95	12.5	70	90	140	80	40	65	90	4 x M6	6 x M6	6 x M6	88.5	31.5	31.7
AU 50 25...	S 50 & NS 50	25	50	112	14	80	100	160	95	50	70	100	4 x M6	6 x M6	6 x M6	103.5	33	33.2
AU 44 34...	M 44 & NM 44	34	44	116	14.5	88	103	153	96	50	80	103	4 x M8	6 x M8	6 x M8	116	38.5	38.7
AU 60 34...	M 60 & NM 60	34	60	135	17	110	125	205	115	60	90	130	4 x M8	6 x M8	6 x M8	132	41	41.2
AU 76 34...	M 76 & NM 76	34	76	150	18	130	165	265	130	80	110	160	4 x M8	6 x M8	6 x M8	148	42	42.2
AU 76 54...	L 76 & NL 76	54	76	185	20	140	198	298	160	90	135	185	4 x M10	6 x M10	6 x M10	182	58.5	58.7
AU 120 54...	L 120 & NL 120	54	120	240	24	180	258	378	210	120	165	225	4 x M10	6 x M10	6 x M10	226	62.5	62.7

### \* Notes:

- Maximum loads quoted assume lubrication at the interface of [Bearings](#) and [Slide](#). This can best be achieved by using [Cap Seals](#) or [Lubricators](#). It is strongly recommended that load and life are determined using the methods shown in the [Calculations](#) section. The bearing static and dynamic load capacities (C & Co) often quoted by manufacturers are not the best basis for practical life calculations. C & Co figures are included on the [Bearing](#) pages for comparison.
- Some dimensions will vary by the amount of the grinding allowance according to which grade of slide is selected. All Carriages are compatible with all grades of [Slide](#) with the exception of the smallest (size 12-13). Two sizes of 12-13 Carriages are therefore required, AU 12P1/P2 13 which is suitable for slide grades P1 & P2, and AU 12P3 13 which is suitable for slide grade P3.
- Carriage size AU 28 18 incorporates a recess in the underside for fixing screw clearance when used with size V28 Flat [Slide](#). The V dimension in the table includes for this recess.
- The datum mark identifies the reference edge used in manufacture. The concentric [Bearings](#) are always mounted on this side.
- CH (Controlled Height) [Bearings](#) are selected to be within  $\pm 0.005$  mm in respect of 'B1' dimension on pages 32-33 compared to Standard Bearings which are within  $\pm 0.025$  mm. Customers requiring CH Bearings with the same tolerance band in respect of a number of Carriages should state this on their order.
- Carriages are available in 3 standard lengths, therefore bearing centres 'D' and the number and position of component mounting holes 'G' will vary accordingly. Hepco will make carriages to your special length requirement on request.
- The carriage plate bearing centres are optimised for use with any precision grade of [slide](#). Customers making their own carriage should calculate their [bearing](#) & [Lubricator/Cap Seal](#) mounting centres for the particular slide grade selected. Please see [Assembled Systems](#) or individual component pages for details of calculations.

# Standard Carriages



**The Nitrile Sealed Bearing option (NS)** provides a higher degree of sealing against ingress of water or debris than does the default metal shielded type. A small increase in friction may result.

**The Controlled Height Bearing option (CH)** minimises variation between Bearings in respect of the important 'Q' dimension. This may be desirable in some high precision applications \*5.

**The Tamper Proof option (T)** which prevents any adjustment or removal of the Bearing assemblies, may be desirable if equipment is to be maintained by untrained personnel.

**The Cap Seal option (CS)** ensures best possible lubrication of the V contact surfaces and protects against ingress of debris. Operational safety and system appearance are also improved. Lubrication vastly increases load capacity and life. Depending on stroke, duty and environmental factors, no further lubrication is required. Access to Cap Seal fixing screws is from the top of the Carriage for ease of adjustment.

**The Lubricator option (LB)** applies oil to the V contact surfaces by means of lightly sprung felt pads which are charged with oil to give long intervals between re-lubrication. The Lubricator option is useful where the advantages of increased load and life are required but with lower friction compared to the Cap Seal.

## Example: Medium Length Carriage with Cap Seals on a Spacer Slide

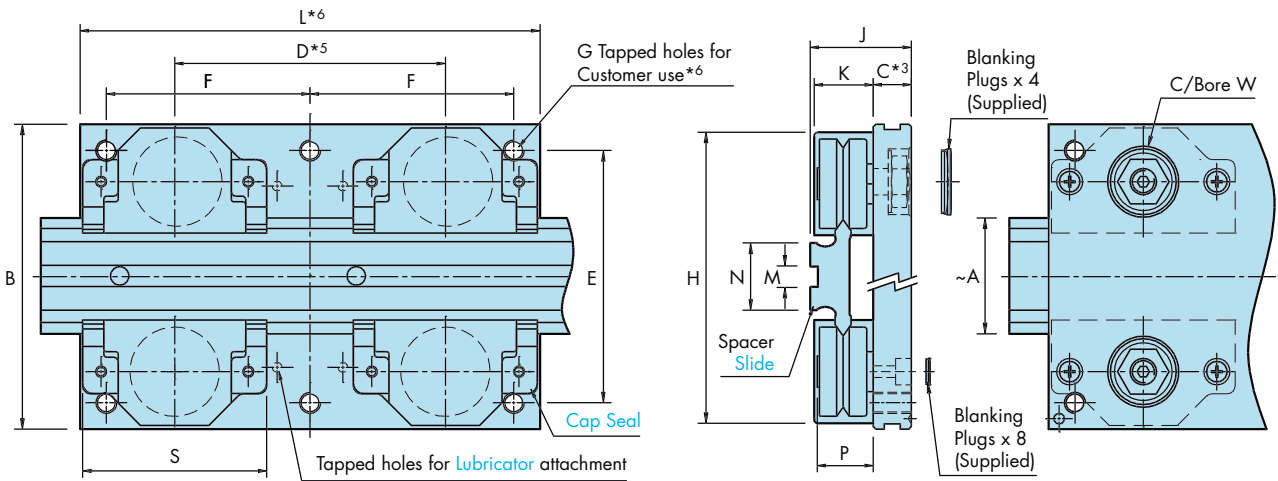

K	L*6			M	N*2			P	Q	R*2			S	T	U	V*2,3	W	~Weight (kg)			Max Load Capacity (N)*1			
	50	75	100		P1 & P2	P3	P1			P2 & P3	Ø x depth	DR L1						DR L2	L1	L2				
-	50	75	100	4 x 1.8	8.5	8.9	10.1	5.46	1.49	1.6	-	7	-	3.8	12.5 x 4.8	0.07	0.09	0.11	-	-	240	240		
-	50	75	100	4 x 1.8	8.5	8.9	10.1	5.46	1.49	1.6	-	7	-	3.8	12.5 x 4.8	0.07	0.09	0.11	-	-	240	240		
14	65	100	140	5 x 2	12	12.4	12.4	6.75	2.1	2.2	42	11	2.5	4.5	16 x 7	0.21	0.27	0.34	760	1200	500	400		
14	75	125	175	6 x 2.5	20	20.4	12.4	6.75	2.1	2.2	42	11	2.5	5.5	16 x 8	0.25	0.36	0.47	760	1200	500	400		
18	80	135	180	6 x 2.5	15	15.4	16.6	9	2.36	2.5	55	13	3	6.5	22 x 8.4	0.41	0.54	0.66	1600	3000	1280	1200		
18	100	150	200	8 x 3	25	25.4	16.6	9	2.36	2.5	55	13	3	6.5	22 x 9.4	0.53	0.7	0.86	1600	3000	1280	1200		
18	110	160	220	10 x 3.5	40	40.4	16.6	9	2.34	2.5	55	13	3	6.5	22 x 10.9	0.67	0.89	1.2	1600	3000	1280	1200		
22.5	125	180	225	8 x 3	26	26.4	21.3	11.5	3.08	3.2	70	15	4	8.3	25 x 8.7	1.1	1.4	1.6	3600	6000	3200	2800		
22.5	150	200	280	10 x 3.5	42	42.4	21.3	11.5	3.05	3.2	70	15	4	8.3	25 x 11	1.5	1.8	2.3	3600	6000	3200	2800		
22.5	170	240	340	12 x 4	58	58.4	21.3	11.5	3.05	3.2	70	15	4	8.3	25 x 12.5	1.8	2.3	3.1	3600	6000	3200	2800		
36.5	200	300	400	15 x 5	50	50.4	34.7	19	4.56	4.7	98	27	6	14.3	32 x 13.5	3.8	4.8	5.8	10000	10000	7200	6400		
36.5	240	360	480	45 x 9.5	94	94.4	34.7	19	4.56	4.7	98	27	6	14.3	32 x 17.5	5.5	7.4	9.3	10000	10000	7200	6400		

## Ordering Details

**AU4434 L180 (CS) (DR) (NS) (CH) (T) + Slide Part Number**

Part Number

**AU...** = Assembled Carriage

**K...** = Kit of parts

**CP...** = Carriage plate only

Carriage Length 'L' = 180mm

Lubrication Options

**CS** for Cap Seals\* or **LB** for Lubricators

Leave blank if not required

**T** = Tamper Proof option

Leave blank if not required

**CH** = Controlled Height Bearings \*5

Leave blank if not required

**NS** = Nitrile Sealed Bearings

Leave blank if not required

**DR** = Double Row Bearings

Leave blank if not required

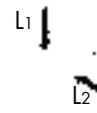

## Availability of Carriage Options

Part Number	-	DR	-	NS	CS	LB	CH	T
AU12...13...	✓	✓	✓	✓	✓	✓	✓	✓
AU 20 18...	✓	✓	✓	✓	✓	✓	✓	✓
AU 28 18...	✓	✓	✓	✓	✓	✓	✓	✓
Larger sizes	✓	✓	✓	✓	✓	✓	✓	✓

\*Not available on short carriages.

Assembled Carriages will be adjusted to the Slide to make a system.

Simply state the number of systems with the number of carriages per slide:

**Example:** 2 x (3 x AU6034 L200 CS DR + NM60 L3056 P1)

(2 systems each with 3 carriages per slide)





# Carriage Locking Device

The Carriage Locking Device has been designed to provide the customer with a safe and simple method of locking a [Standard Carriage](#) in position to facilitate processes where a secure, stationary platform is required. The clamping force is reacted out across the opposing V faces of the slide and unlike some other systems, does not impose any load upon the bearings or cause deflection of the carriage even when high holding force is applied.

The Carriage Locking Device is intended for manual locking of a carriage when in its stationary condition and is available factory assembled in Standard Carriage format only for sizes AU25-25 and above. It is suitable for use with either [Spacer Slides](#) (as illustrated) or [Flat Slides](#) in all 3 grades of precision.

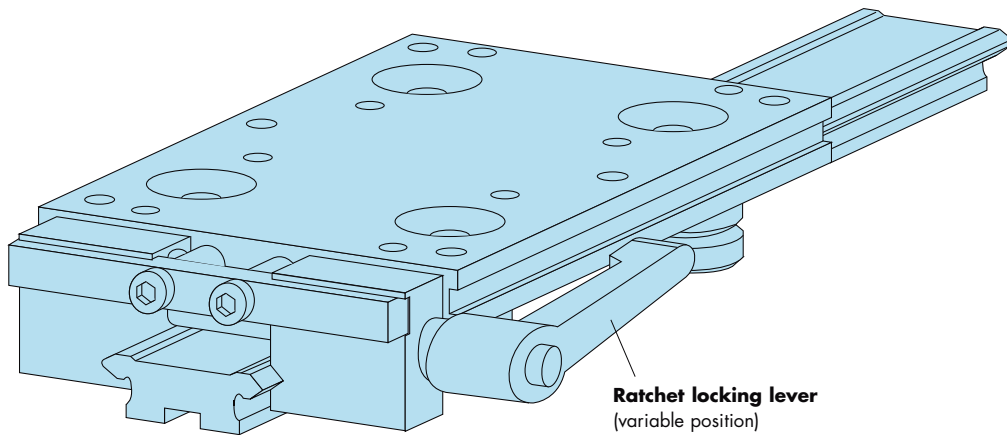

Part No.	A	B	C	D	E	F	G lever disengaged	H	J
BK2525	78	16	21.5	26.5	57	33.5	37.0	28.0	18.4
BK3525	88	16	21.5	26.5	57	31.0	34.5	29.0	18.4
BK5025	103	16	21.5	26.5	57	30.0	33.5	30.5	18.4
BK4434	116	16	23.5	29.5	83	51.5	55.0	35.0	22.4
BK6034	132	16	23.5	29.5	83	50.0	53.5	37.5	22.4
BK7634	148	16	23.5	29.5	83	50.5	54.0	38.5	22.4
BK7654	164	20	33.5	41.5	105	53.0	57.0	54.0	34.9
BK12054	208	20	33.5	41.5	105	47.5	51.5	58.0	34.9

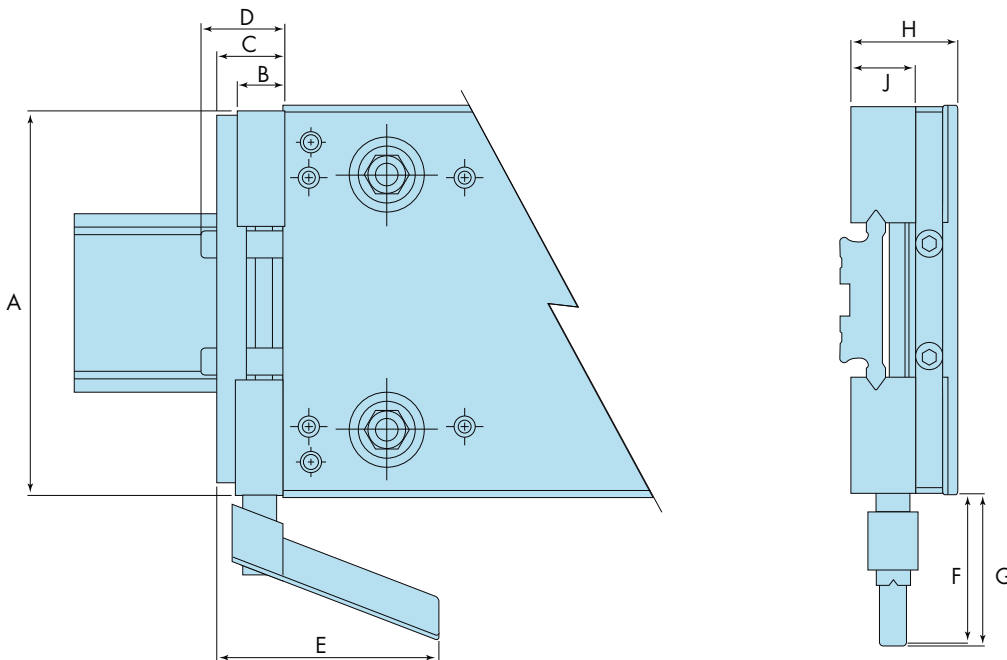

To order - simply add the above part number to standard carriage reference.  
**Example: AU2525L180CS+BK2525**

# Shock Absorber Fixing Blocks

Hepco SH Shock Absorbers are a cost effective means of significantly increasing the life of a GV3 slide system by reducing stress on the internal elements and fixings as well as by reducing wear on the slide in the crucial deceleration zone. Hepco Shock Absorbers will allow higher operating speeds to be achieved, reduce maintenance costs, lower noise levels, and enhance safety in the event of control system failure. Shock Absorber Fixing Blocks are supplied ready assembled to the [Spacer Slide](#) to provide a strong fixing capable of withstanding high deceleration forces. They are compatible with Standard, Removable and Slimline [Carriages](#).

Smaller sizes of Fixing Block (see table) are bolted direct to the end of the Slide whilst larger sizes are bolted to the top surface. The top surface mounting position is normally at the end of the slide as shown, but may be specified at any position. This may be useful in cases where a number of carriages run on the same slide. Top surface mounting Fixing Blocks can also be used with [Flat Slides](#). In this case the slide is supplied drilled clearance for the screws and it will be necessary for customers to provide tapped fixing holes in the mounting surface of their machine.

**Details of shock absorbers may be found in the Hepco SH Shock Absorber catalogue. They should be ordered separately, complete with the Soft Pad option.**

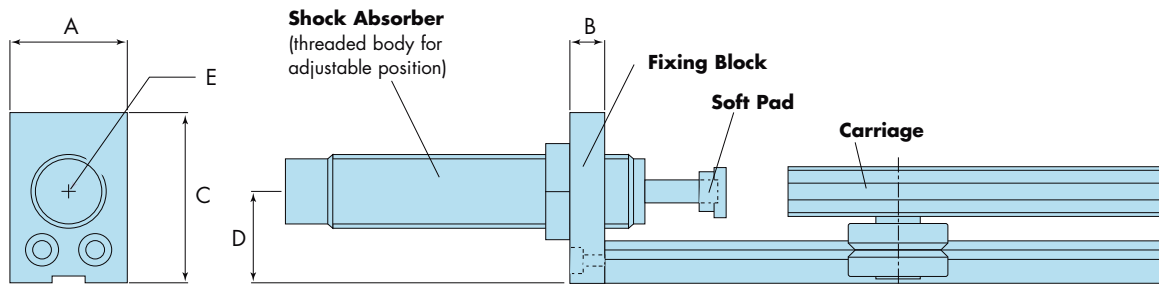

Ordering example: **NS35L1290P3** + 1 x **SHBS3520** (1x = Fixing bracket one end, 2x = fixing bracket both ends)

Fixing block part No.	Fits slide	For shock absorber	A	B	C	D	E
SHBS 35 20	NS 35	SH20	30	12	40	25.5	M20X1.5
SHBS 50 20	NS 50	SH20	40	15	45	26.1	M20X1.5
SHBS 50 25	NS 50	SH25	40	15	45	26.1	M25X1.5
SHBM 44 20	NM 44	SH20	40	15	50	31.4	M20X1.5
SHBM 44 25	NM 44	SH25	40	15	50	31.4	M25X1.5
SHBM 60 20	NM 60	SH20	44	15	50	32.7	M20X1.5
SHBM 60 25	NM 60	SH25	44	15	50	32.7	M25X1.5

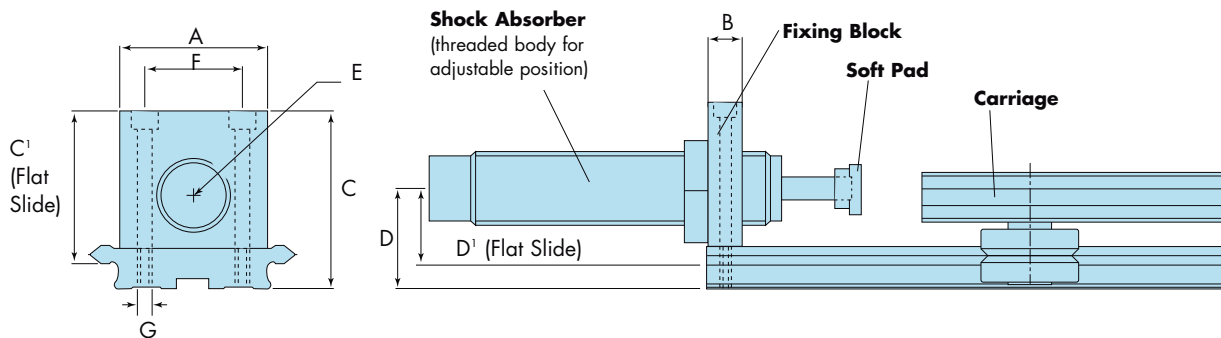

Ordering example: **NL120L1616P2** + 1 x **SHBL12036** (1x = Fixing bracket one end, 2x = fixing bracket both ends)

Fixing block part No.	Fits slide	For shock absorber	A	B	Max (with P2/P3 Slide)				E	F	G
					C	C'	D	D'			
SHBM 76 20	M & NM 76	SH20	55	15	65.2	56.5	33.3	24.5	M20X1.5	37	M8
SHBM 76 25	M & NM 76	SH25	55	15	65.2	56.5	33.3	24.5	M25X1.5	37	M8
SHBL 76 20	L & NL 76	SH20	55	15	73.7	59.5	49.0	34.7	M20X1.5	37	M8
SHBL 76 25	L & NL 76	SH25	55	15	73.7	59.5	49.0	34.7	M25X1.5	37	M8
SHBL 120 20	L & NL 120	SH20	90	15	73.7	59.5	50.7	36.4	M20X1.5	70	M8
SHBL 120 25	L & NL 120	SH25	90	15	73.7	59.5	50.7	36.4	M25X1.5	70	M8
SHBL 120 36	L & NL 120	SHA3625/3650	90	15	73.7	59.5	50.7	36.4	M36X1.5	70	M8



# Removable Carriages



Hepco Removable Carriages are available to suit all sizes and types of Double Edge Slide in all grades of precision. Each Carriage comes complete with 4 Standard Bearings and is available in 3 useful lengths to cater for customers' component size and offset load requirements. The Carriage Plates are fully machined from aluminium alloy and are supplied anodised. Tapped holes are provided in convenient positions to enable components to be attached.

The key feature of Removable Carriages is the incorporation of **Double Eccentric Bearings**. By slackening the Bearing stud fixing nuts and rotating the eccentric using the adjusting spanner, the Carriage can be disengaged from the Slide (see diagram on page 8). This can be a considerable advantage over Standard and Slimline Carriages, which must either be run off the end of the Slide, or be disassembled to allow removal.

Carriages may be specified as **Assembled Units (AU type)** which are factory assembled and set to the Slide. Alternatively, the carriage may be specified as a **kit of components (K type)** for customers wishing to carry out their own assembly.

The following types or options of Bearing and lubrication device may be specified (refer also to availability table below right).

**See Application Example on page 8**

## Example: Short Carriage with Lubricators on a Flat Slide

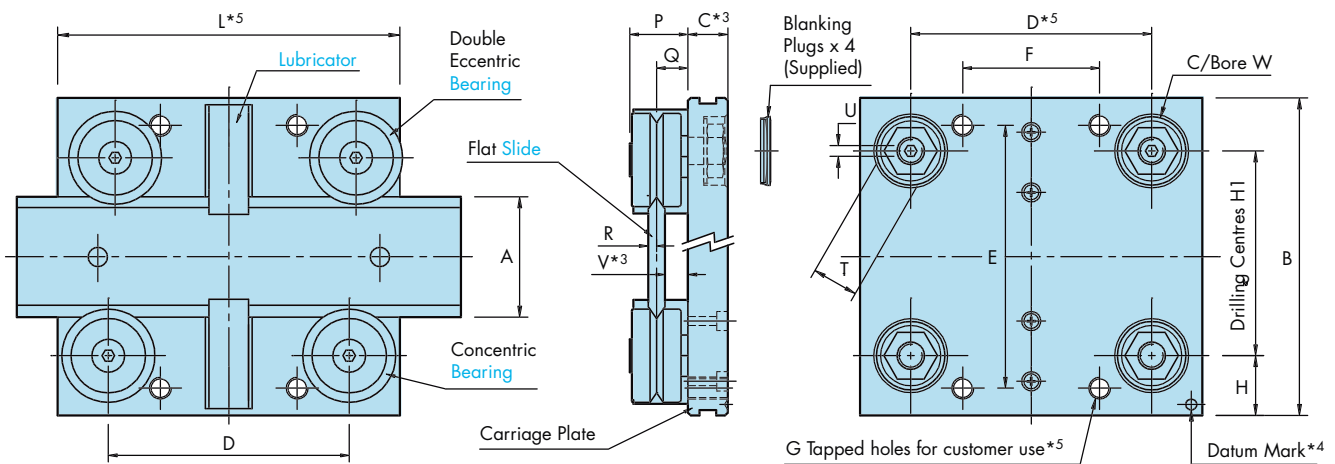

Part Number	For Use With Slides	Bearing Ø	A	B	C	D*5			E	F*5		G*5 No of Holes x Thread	H	H1	J*2		
						35	60	85		17	25				50	P1	P2 & P3
AU 12 13 R...	MS 12 & NMS 12	13	12	40	7.34	35	60	85	30	17	25	50	9	23.3	19	19.2	
AU 20 18 R...	V 20 & NV 20	18	20	64	10	43	55	95	50	20	88	124	14.7	35.9	24.75	24.95	
AU 28 18 R...	V 28 & NV 28	18	28	72	11	52	80	130	58	25	110	160	14.7	43.9	25.75	25.95	
AU 25 25 R...	S 25 & NS 25	25	25	80	11.5	51	74	120	65	24	120	164	16.7	48.3	30.5	30.7	
AU 35 25 R...	S 35 & NS 35	25	35	95	12.5	70	90	140	80	40	130	180	19.2	58.3	31.5	31.7	
AU 50 25 R...	S 50 & NS 50	25	50	112	14	80	100	160	95	50	140	200	20.2	73.3	33	33.2	
AU 44 34 R...	M 44 & NM 44	34	44	116	14.5	88	103	153	96	50	160	206	21.9	74.8	38.5	38.7	
AU 60 34 R...	M 60 & NM 60	34	60	135	17	110	125	205	115	60	180	260	23.4	90.8	41	41.2	
AU 76 34 R...	M 76 & NM 76	34	76	150	18	130	165	265	130	80	220	320	22.9	106.8	42	42.2	
AU 76 54 R...	L 76 & NL 76	54	76	185	20	140	198	298	160	90	270	370	33	123	58.5	58.7	
AU 120 54 R...	L 120 & NL 120	54	120	240	24	180	258	378	210	120	330	450	38.5	167	62.5	62.7	

### \* Notes:

- Maximum loads quoted assume lubrication at the interface of Bearings and Slide. This can best be achieved by using Lubricators. It is strongly recommended that load and life are determined using the methods shown in the Calculations section. The bearing static and dynamic load capacities (C & Co) often quoted by manufacturers are not the best basis for practical life calculations. C & Co figures are included on the Bearing pages for comparison.
- Some dimensions will vary by the amount of the grinding allowance according to which grade of slide is selected. All Carriages are compatible with all grades of Slide.
- Carriage size AU 28 18 R incorporates a recess in the underside for fixing screw clearance when used with size V28 Flat Slide. The V dimension in the table includes for this recess.
- The Datum mark identifies the reference edge used in manufacture. The concentric Bearings are always mounted on this side.
- Carriages are available in 3 standard lengths, therefore bearing centres 'D' and the position of component mounting holes 'G' will vary accordingly. Hepco will make carriages to your special length requirement on request.



# Removable Carriages



**The Twin Bearing type** which is the default choice, comprises two individual bearings on a common stud. This offers some compliance, with smoother running, easy adjustment and greater tolerance of misalignment.

**The Double Row Bearing type (DR)** incorporates a one-piece bearing with two ball tracks. This offers higher load capacity, especially in the radial direction and is less susceptible to entrapment of debris.

**The Nitrile Sealed Bearing option (NS)** provides a higher degree of sealing against ingress of water or debris than does the default metal shielded type. A small increase in friction may result.

**The Lubricator option (LB)** applies oil to the V contact surfaces by means of lightly sprung felt pads which are charged with oil to give long intervals between re-lubrication. The Lubricator option is useful where the advantages of increased load and life are required in conjunction with low friction.

Lubricators are fixed with screws through the carriage, so that they can be detached easily in the event of carriage removal from the Slide.

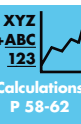

## Example: Medium Length Carriage on a Spacer Slide

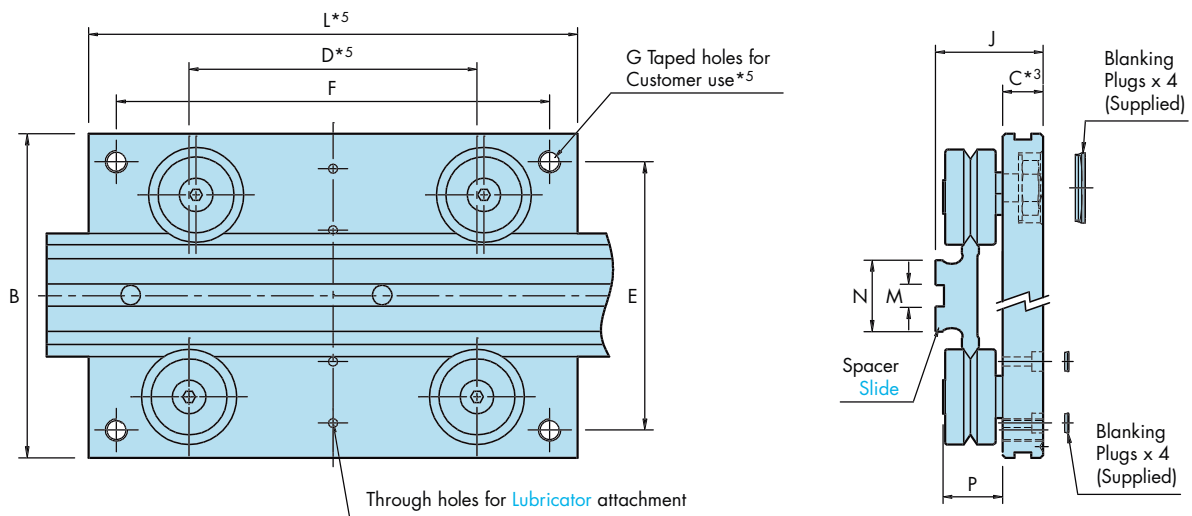

	L*5			M	N*2		P	Q	R*2		T	U	V*2,3	W	~Weight (kg)			Max Load Capacity (N)*1			
					P1 & P2	P3			P1	P2 & P3											
	50	75	100	4 x 1.8	8.5	8.9	10.1	5.46	1.49	1.6	7	-	3.8	12.5 x 4.8	0.07	0.09	0.11	-	-	240	240
	65	100	140	5 x 2	12	12.4	12.4	6.75	2.1	2.2	11	2.5	4.5	16 x 7	0.21	0.27	0.34	760	1200	500	400
	75	125	175	6 x 2.5	20	20.4	12.4	6.75	2.1	2.2	11	2.5	5.5	16 x 8	0.25	0.36	0.47	760	1200	500	400
	80	135	180	6 x 2.5	15	15.4	16.6	9	2.36	2.5	13	3	6.5	22 x 8.4	0.41	0.54	0.66	1600	3000	1280	1200
	100	150	200	8 x 3	25	25.4	16.6	9	2.36	2.5	13	3	6.5	22 x 9.4	0.53	0.7	0.86	1600	3000	1280	1200
	110	160	220	10 x 3.5	40	40.4	16.6	9	2.34	2.5	13	3	6.5	22 x 10.9	0.67	0.89	1.2	1600	3000	1280	1200
	125	180	225	8 x 3	26	26.4	21.3	11.5	3.08	3.2	15	4	8.3	25 x 8.7	1.1	1.4	1.6	3600	6000	3200	2800
	150	200	280	10 x 3.5	42	42.4	21.3	11.5	3.05	3.2	15	4	8.3	25 x 11	1.5	1.8	2.3	3600	6000	3200	2800
	170	240	340	12 x 4	58	58.4	21.3	11.5	3.05	3.2	15	4	8.3	25 x 12.5	1.8	2.3	3.1	3600	6000	3200	2800
	200	300	400	15 x 5	50	50.4	34.7	19	4.56	4.7	27	6	14.3	32 x 13.5	3.8	4.8	5.8	10000	10000	7200	6400
	240	360	480	45 x 9.5	94	94.4	34.7	19	4.56	4.7	27	6	14.3	32 x 17.5	5.5	7.4	9.3	10000	10000	7200	6400

## Ordering Details

**AU4434 L180 R (LB) (DR) (NS) + Slide Part Number**

- Part Number **AU**... = Assembled Carriage
- K**... = Kit of parts
- CP**... = Carriage plate only
- Carriage Length 'L' = 180mm
- R** = Removable Type Carriage

- NS** = Nitrile Sealed Bearings  
Leave blank if not required
- DR** = Double Row Bearings  
Leave blank if not required
- Lubrication Option: **LB** for Lubricators  
Leave blank if not required

## Availability of Carriage Options

Part Number	-	DR	-	NS	LB
	Twin Bearings	Double Row	Metal Shields	Nitrile Seals	Lubricators
AU 12 13 R...	✓	X	X	✓	✓
AU 20 18 R...	✓	✓	X	✓	✓
AU 28 18 R...	✓	✓	X	✓	✓
Larger sizes	✓	✓	✓	✓	✓

Assembled Carriages will be adjusted to the Slide to make a system. Simply state the number of systems with the number of carriages per slide:

**Example: 2 x (3 x AU4434 L180 R LB NS + NM44 L3146 P2)**

(2 systems each with 3 carriages per slide)

# Slimline Carriages



Hepco Slimline Carriages are available to suit all sizes and types of Double Edge Slide in all grades of precision. Each Carriage comes complete with 4 Slimline Bearings which ensure that the overall system height is minimised. Slimline Carriages have a lower load capacity than corresponding sizes of Standard Carriage, but benefit from being lower in cost. All sizes are available in 3 useful lengths to cater for customers' component size and offset load requirements. The Carriage Plates are fully machined from aluminium alloy and are supplied anodised. Tapped holes are provided in convenient positions to enable components to be attached.

Carriages may be specified as **Assembled Units (AU type)** which are factory assembled and set to the Slide. Alternatively, the carriage may be specified as a **kit of components (K type)** for customers wishing to carry out their own assembly.

The following types or options of Bearing and lubrication device may be specified (refer also to availability table below right).

**See Application Example on page 10**

## Example: Short Carriage with Lubricators on a Flat Slide

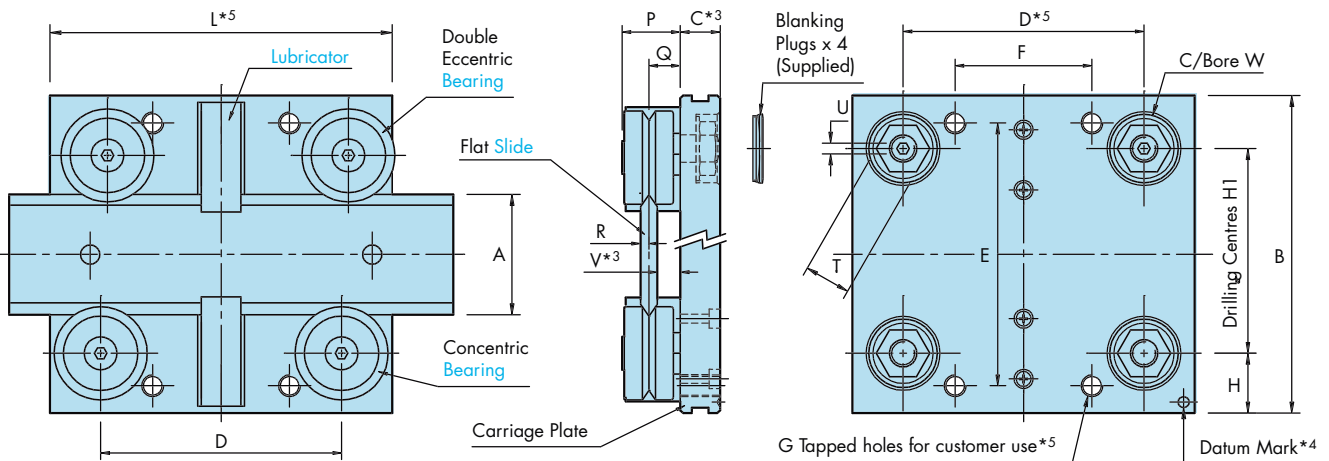

Part Number	For Use With Slides	Bearing Ø	A	B	C	D*5			E	F*5			G*5 No of Holes x Thread			H	J*2	
						4	5	6		7	8	9	10	11	12		13	14
AU 20 195...	V 20 & NV 20	19.5	20	64	10	43	55	90	50	20	44	62	4 x M5	6 x M5	6 x M5	59	23.7	23.9
AU 28 195...	V 28 & NV 28	19.5	28	72	11	52	75	125	58	25	55	80	4 x M5	6 x M5	6 x M5	67	24.7	24.9
AU 25 265...	S 25 & NS 25	26.5	25	80	11.5	55	74	120	65	25	60	82	4 x M6	6 x M6	6 x M6	76	28.3	28.5
AU 35 265...	S 35 & NS 35	26.5	35	95	12.5	70	90	140	80	40	65	90	4 x M6	6 x M6	6 x M6	86	29.3	29.5
AU 50 265...	S 50 & NS 50	26.5	50	112	14	80	100	160	95	50	70	100	4 x M6	6 x M6	6 x M6	101	30.8	31
AU 44 360...	M 44 & NM 44	36	44	116	14.5	85	98	145	96	50	80	103	4 x M8	6 x M8	6 x M8	113	35.3	35.5
AU 60 360...	M 60 & NM 60	36	60	135	17	108	120	200	115	60	90	130	4 x M8	6 x M8	6 x M8	129	37.8	38
AU 76 360...	M 76 & NM 76	36	76	150	18	128	160	260	130	80	110	160	4 x M8	6 x M8	6 x M8	145	38.8	39
AU 76 580...	L 76 & NL 76	58	76	195	20	135	190	290	170	90	135	185	4 x M10	6 x M10	6 x M10	186	53.3	53.5
AU 120 580...	L 120 & NL 120	58	120	240	24	185	240	360	210	120	165	225	4 x M10	6 x M10	6 x M10	230	57.8	58

### \* Notes:

- Maximum loads quoted assume lubrication at the interface of Bearings and Slide. This can best be achieved by using Cap Wipers or Lubricators. It is strongly recommended that load and life are determined using the methods shown in the Calculations section. The bearing static and dynamic load capacities (C & Co) often quoted by manufacturers are not the best basis for practical life calculations. C & Co figures are included on the Bearing pages for comparison.
- Some dimensions will vary by the amount of the grinding allowance according to which grade of slide is selected. All Carriages are compatible with all grades of Slide.
- All Carriages except sizes AU 76 580 & AU 120 580 incorporate a recess in the underside for fixing screw clearance when used with Flat Slides. The V dimension in the table includes for this recess.
- The Datum mark identifies the reference edge used in manufacture. The concentric Bearings are always mounted on this side.
- Carriages are available in 3 standard lengths, therefore bearing centres 'D' and the number and position of component mounting holes 'G' will vary accordingly. Hepco will make carriages to your special length requirement on request.
- The carriage plate bearing centres are optimised for use with any precision grade of slide. Customers making their own carriage should calculate their bearing and Lubricator/Cap Wiper mounting centres for the particular slide grade selected. Please see Assembled Systems or individual component pages for details of calculations.

# Slimline Carriages



The **Nitrile Sealed Bearing option (NS)** provides a higher degree of sealing against ingress of water or debris than does the default metal shielded type. A small increase in friction may result.

The **Tamper Proof option (T)** which prevents any adjustment or removal of the Bearing assemblies, may be desirable if equipment is to be maintained by untrained personnel.

The **Cap Wiper option (CW)** ensures best possible lubrication of the V contact surfaces and protects against ingress of debris. Operational safety and system appearance are also improved. Lubrication vastly increases load capacity and life. Depending on stroke, duty and environmental factors, no further lubrication is required. Access to Cap Wiper fixing screws is from the underside of the Carriage.

The **Lubricator option (LB)** applies oil to the V contact surfaces by means of lightly sprung felt pads which are charged with oil to give long intervals between re-lubrication. The Lubricator option is useful where the advantages of increased load and life are required but with lower friction compared to the **Cap Wiper**.

## Example: Medium Length Carriage with Cap Wipers on a Spacer Slide

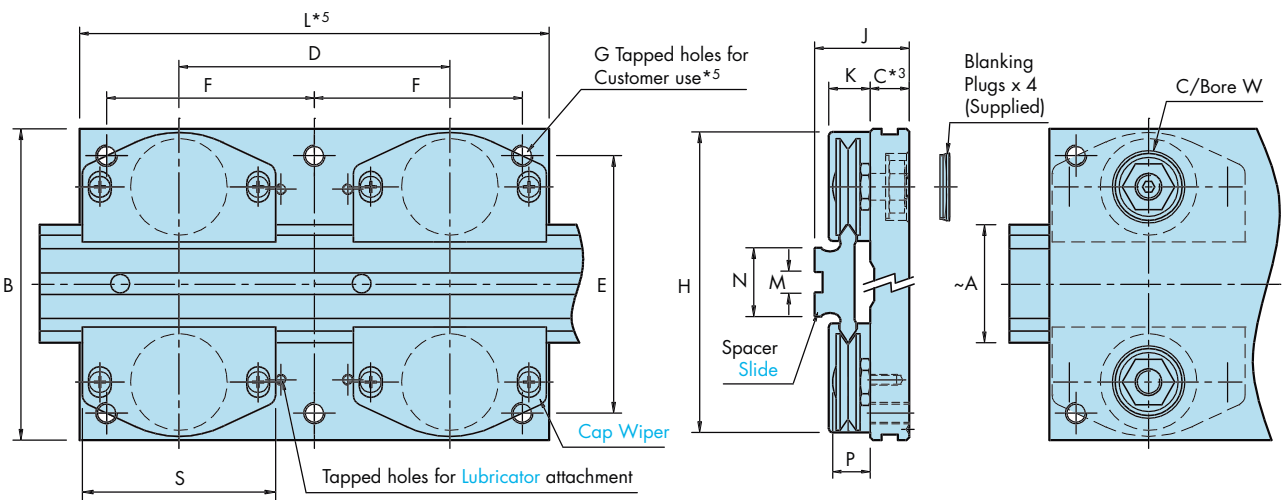

	K	L*5			M	N*2		P	Q	R*2		S	T	U	V	W Ø x depth	~Weight (kg)			Max Load Capacity (N)*	
		P1 & P2	P3	P1		P2 & P3	L1			L2											
	11.2	65	100	140	5 x 2	12	12.4	9.2	5.7	2.1	2.2	43	11	2.5	4.5	16 x 7	0.21	0.27	0.34	400	480
	11.2	75	125	175	6 x 2.5	20	20.4	9.2	5.7	2.1	2.2	43	11	2.5	4.5	16 x 8	0.25	0.36	0.47	400	480
	13	85	135	180	6 x 2.5	15	15.4	11.3	6.8	2.36	2.5	54	13	3	6.5	22 x 8.4	0.37	0.51	0.63	940	1150
	13	100	150	200	8 x 3	25	25.4	11.3	6.8	2.36	2.5	54	13	3	6.5	22 x 9.4	0.5	0.66	0.83	940	1150
	13	110	160	220	10 x 3.5	40	40.4	11.3	6.8	2.34	2.5	54	13	3	6.5	22 x 10.9	0.64	0.86	1.1	940	1150
	15.5	125	180	225	8 x 3	26	26.4	14	8.3	3.08	3.2	72	15	4	7.3	25 x 8.7	0.95	1.2	1.4	2000	2400
	15.5	150	200	280	10 x 3.5	42	42.4	14	8.3	3.05	3.2	72	15	4	7.9	25 x 11	1.3	1.6	2.2	2000	2400
	15.5	170	240	340	12 x 4	58	58.4	14	8.3	3.05	3.2	72	15	4	7.9	25 x 12.5	1.7	2.2	3	2000	2400
	25	200	300	400	15 x 5	50	50.4	22.8	14.3	4.56	4.7	106	27	6	9.6	32 x 13.5	3.8	3.5	4.5	4240	5200
	25	240	360	480	45 x 9.5	94	94.4	22.8	14.3	4.56	4.7	106	27	6	9.6	32 x 17.5	5.3	7.2	9.1	4240	5200

## Ordering Details

### AU44360 L180 (CW) (NS) (T) + Slide Part Number

Part Number **AU**... = Assembled Carriage  
**K**... = Kit of parts  
**CP**... = Carriage plate only  
 Carriage Length 'L' = 180mm

**T** = Tamper Proof option  
 Leave blank if not required  
**NS** = Nitrile Sealed Bearings  
 Leave blank if not required  
**CW** for Cap Wipers\* or **LB** for Lubricators  
 Leave blank if not required

### Availability of Carriage Options

Part Number	Metal Shields	NS	CW	LB	T
AU 20 195...	X	✓	✓	✓	✓
AU 28 195...	X	✓	✓	✓	✓
Larger sizes	✓	✓	✓	✓	✓

\*Not available on short carriages.

Assembled Carriages will be adjusted to the Slide to make a system.  
 Simply state the number of systems with the number of carriages per slide:

**Example: 2 x (2 x AU35265 L200 CW + S35 L3146 P3)**

(2 systems each with 2 carriages per slide)

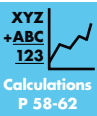

# Double Edge Spacer Slides

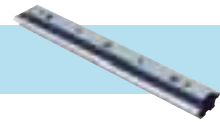

Hepco Double Edge Spacer Slides are available in 11 sizes and three precision grades to meet exactly the requirements of almost any linear motion application. They are zone hardened on the 'V' edges to provide an extremely hard wearing surface. Grades P1 & P2 are precision ground on the V running faces to a high degree of accuracy and parallelism, with P1 being ground on the mounting surface as well. The unground version P3 is also sufficiently accurate for many applications. Please see [System Selector](#) for comparative data.

In addition to the fixing hole options shown below, Slides are also available without holes if preferred. Slide fixing holes are accurately positioned, allowing customers to pre-drill their mounting holes. All Hepco Slides are left 'soft' in the centre portion to allow for subsequent machining if required.

The one piece construction of the Spacer Slide bolts directly to the mounting surface of the machine, providing the required running clearance for [Bearings](#) and [Lubrication Devices](#). A central keyway is provided for simple location by means of Hepco Dowel Pins or customer's own key. In cases where Cap Seals or Lubricators are not being used, the precision datum edges on the spacer portion of the Slide may be used for location against a machined register\*5.

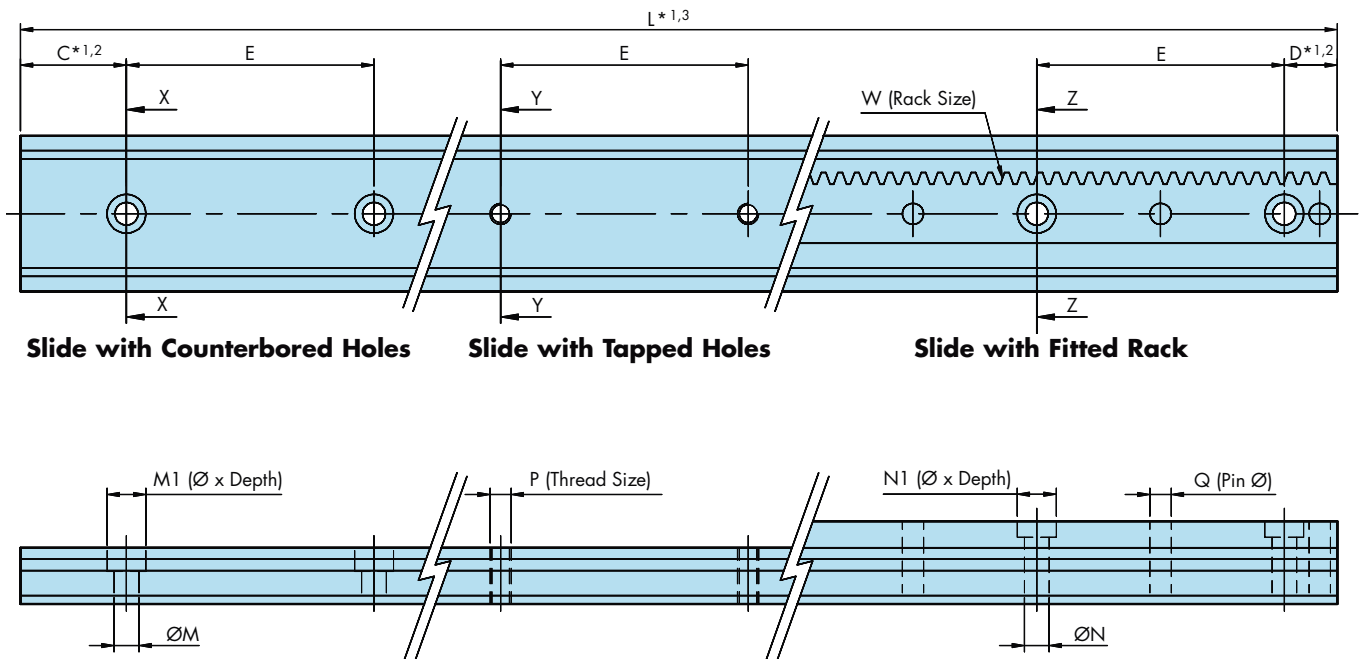

Part Number	Use With Bearings*4		A -Slide Width	B			C & D*1,2		E ±0.2	F		G		H	H1	J		K	L Max*1,3	
	Standard	Slimline		P1 & P2	P3	Slide only	with rack	P1		P2 & P3	P1	P2 & P3	P1 & P2			P3	P1 & P2		P3	
NMS 12...	...J13...	-	12	12.37	13.25	20.5	20.5	45	3.0	3.2	6.2	6.4	4	1.8	8.5	8.9	1.7	1976	1976	
NV 20...	...J18...	...J195...	20	20.37	21.01	43	15	90	4.21	4.42	8	8.2	5	2	12	12.4	1.75	4020	4020	
NV 28...	...J18...	...J195...	28	28.37	29.01	43	15	90	4.21	4.42	8	8.2	6	2.5	20	20.4	1.75	4020	4020	
NS 25...	...J25...	...J265...	25	25.74	26.58	43	15	90	4.71	4.93	10	10.2	6	2.5	15	15.4	2.6	4020	4020	
NS 35...	...J25...	...J265...	35	35.74	36.38	43	15	90	4.71	4.93	10	10.2	8	3	25	25.4	2.6	4020	4020	
NS 50...	...J25...	...J265...	50	50.74	51.38	43	15	90	4.71	4.93	10	10.2	10	3.5	40	40.4	2.6	4020	4020	
NM 44...	...J34...	...J360...	44	44.74	45.58	43	15	90	6.21	6.42	12.5	12.7	8	3	26	26.4	2.3	4020	6000	
NM 60...	...J34...	...J360...	60	60.74	61.38	43	15	90	6.21	6.42	12.5	12.7	10	3.5	42	42.4	2.3	4020	6000	
NM 76...	...J34...	...J360...	76	76.74	77.38	43	15	90	6.21	6.42	12.5	12.7	12	4	58	58.4	2.3	4020	6000	
NL 76...	...J54...	...J580...	76	76.74	77.58	88	30	180	9.21	9.43	19.5	19.7	15	5	50	50.4	4.8	4020	6000	
NL 120...	...J54...	...J580...	120	120.74	121.38	88	30	180	9.21	9.43	19.5	19.7	45	9.5	94	94.4	4.8	4020	6000	

## Notes:

- Any length of Slide within L max dimension can be supplied, but for optimum price and delivery time, Slide lengths should be specified which maintain the C and D dimensions in the table above. In all cases unless otherwise specified by the customer, C and D dimensions will be supplied equal. The positions of the teeth on the rack mounted versions relative to the mounting holes or slide ends, will vary. Rack mounted Slides with a regulated tooth position can be supplied on request.
- The C & D dimensions for rack mounted slides are less than that for plain versions to provide support for the rack close to its end. Slide lengths which require C & D dimensions which differ from this may require an extra hole at a non-standard pitch.
- Where Slides longer than the maximum length are required, lengths can be matched suitable for butting.
- In the table, the preferred choices of [Bearings](#) to use with each Slide are quoted. However, other combinations are possible (please see [Mix and Match](#) page).
- Slides in their free unmounted state are not necessarily absolutely straight. If straightness is important, the slide may be set by bolting down against a register or by utilising the central keyway. If Hepco Dowel Pins are used, these should be positioned one each end centrally between the Slide end and first hole and one located centrally between each pair of fixing holes, or as deemed necessary for the application.
- The NL120 section recess has a wider tolerance than the keyways in the other sections. One side only should be used as a register face if precise straightness is important.
- Low head cap screws DIN 6912 are not universally stocked, so Hepco offers them as a convenience to customers in a single length for each thread size (see table). The NL120 Rack Slide Assembly (and all plain Double Edged Spacer Slides) is secured with cap screws to DIN 912 which are widely stocked.

# Double Edge Spacer Slides

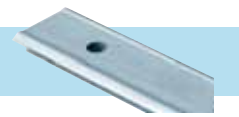

The rigidity of the Spacer Slide enables it to be used as a self-supporting element or construction member of the machine, when used in conjunction with Hepco [Flange Clamps](#). Slide deflection is covered in the [Calculations](#) section.

All Double Edge Spacer Slides with the exception of the smallest are available with a rack attached by dowels to the top surface. This becomes a fully serviceable element when bolted down to the mounting surface, providing a convenient means to power the linear movement. Rack teeth are machined to a high degree of precision and conform to ISO 1328 grade 8. Racks may comprise a number of lengths, precision mounted to a single Slide. [Pinions](#) which mate with these Racks are included in the GV3 range as are Rack [Driven Carriages](#) which mount directly to the Slide and may be specified with optional AC Motor, to provide a complete drive solution.

Note that Double Edge Spacer Slides with the fitted rack option are not compatible with Carriages using the Slimline Bearings, as there is no clearance for the Rack.

**See Application Examples on pages 9, 10, 11, 12, 13, 14 & 15**

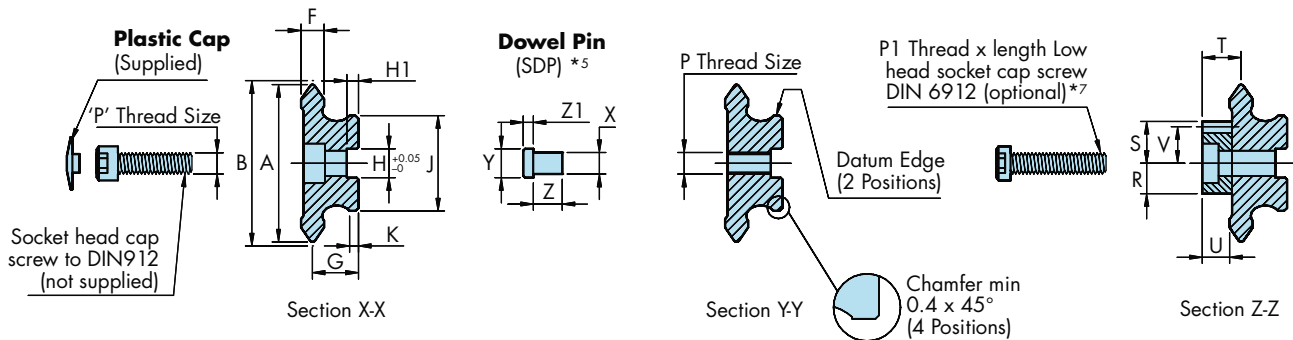

## Available Grades of Slide

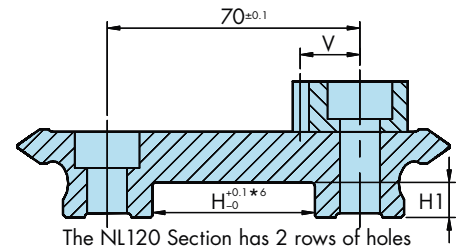
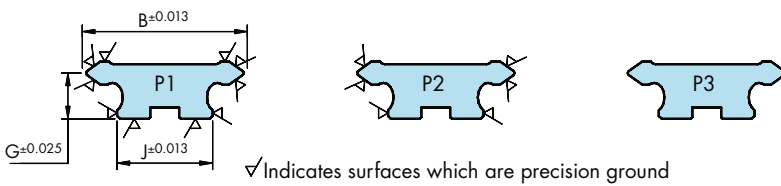

M	M1	N	N1	P	P1*7		Q	R	S	T	U	V	W	Dowel Pin	X	Y	Z	Z1	Weight - kg/m		Part Number
					Screw	Part No.													Slide Only	Slide + Rack	
3.5	6.2 x 3.1	-	-	M3	-	-	-	-	-	-	-	-	-	SDP4	4	4	6.75	-	0.5	-	NMS 12...
4.5	8 x 4.1	4.5	7.6 x 2.9	M4	M4 x 20	FS420	4	6.35	6.35	6.2	4	5.65	0.7	SDP5	4	5	6	1.75	1.0	1.4	NV 20...
5.5	10 x 5.1	4.5	7.6 x 2.9	M5	M4 x 20	FS420	4	6.35	6.35	6.2	4	5.65	0.7	SDP6	4	6	6	2.25	1.6	2.0	NV 28...
5.5	10 x 5.1	5.5	9.6 x 4	M5	M5 x 25	FS525	5	7.8	7.85	8.5	6	6.85	1	SDP6	4	6	6	2.25	1.5	2.3	NS 25...
7	11 x 6.1	5.5	9.6 x 4	M6	M5 x 25	FS525	5	7.8	7.85	8.5	6	6.85	1	SDP8	6	8	8	2.75	2.3	3.0	NS 35...
7	11 x 6.1	5.5	9.6 x 4	M6	M5 x 25	FS525	5	7.8	7.85	8.5	6	6.85	1	SDP10	8	10	12	3.25	3.2	4.0	NS 50...
7	11 x 6.1	6.5	11 x 4.5	M6	M6 x 30	FS630	6	8.3	11.7	10.8	7.5	10.2	1.5	SDP8	6	8	8	2.75	3.5	4.7	NM 44...
9	15 x 8.1	6.5	11 x 4.5	M8	M6 x 30	FS630	6	8.3	11.7	10.8	7.5	10.2	1.5	SDP10	8	10	12	3.25	5.5	5.7	NM 60...
9	15 x 8.1	6.5	11 x 4.5	M8	M6 x 30	FS630	6	8.3	11.7	10.8	7.5	10.2	1.5	SDP12	10	12	15	3.75	7	8.2	NM 76...
14	20 x 12	14	20 x 8	M12	M12 x 50	FS1250	8	13.2	18.6	18	13.3	16.6	2	SDP15	10	15	15	4.75	10	13	NL 76...
11	18 x 10	11	18 x 10	M10	-	-	8	13.2	18.6	18	13.3	16.6	2	-	-	-	-	-	15	18	NL 120...

## Ordering Details

**NS35 L1290 P1 (R) (T) (C15) (D15)**

Part Number \_\_\_\_\_  
 Slide Length 'L' = **1290** mm \_\_\_\_\_  
 Precision grade: options are **P1, P2 & P3** \_\_\_\_\_  
**R** - Rack mounted on Slide (not available on NMS12) \_\_\_\_\_  
 Leave blank if not required \_\_\_\_\_  
 Bespoke values of 'C' & 'D' dimensions \_\_\_\_\_  
 Leave blank if standard\*1,2 \_\_\_\_\_  
 Fixing hole style: **T** - tapped fixing holes; **N** - no holes \_\_\_\_\_  
 leave blank for counterbored holes (Options **T** & **N** are \_\_\_\_\_  
 only available with Rack option to special order)

### Example:

1 x NM60 L480 P2 R \_\_\_\_\_ Double Edge Spacer Slide x 480 mm long in precision grade 2, fitted with Rack.  
 7 x SDP10 \_\_\_\_\_ 10 mm Ø Dowel Pins (optional).  
 6 x FS630 \_\_\_\_\_ Low head socket cap screws M6 thread x 30 mm long (optional).



# Single Edge Spacer Slides



Hepco Single Edge Spacer Slides are available in 5 sizes and three precision grades. They are zone hardened on the 'V' edge to provide an extremely hard wearing surface. Grades P1 & P2 are precision ground on the V faces and datum edges to a high degree of accuracy and parallelism, with P1 being ground on the top and bottom faces as well. The unground version P3 is also sufficiently accurate for many applications (please see [System Selector](#) for comparative data).

In addition to the fixing hole options shown below, Slides are available without holes if preferred. Slide fixing holes are accurately positioned, allowing customers to pre-drill their mounting holes\*5. All Hepco Slides are left 'soft' in the centre portion to allow subsequent machining if required.

The one piece construction of the Spacer Slide bolts directly to the mounting surface of the machine, providing the required running clearance for [Bearings](#) and [Lubrication Devices](#). A central keyway is provided for simple location by means of Hepco dowel pins or customer's own key. In cases where Cap Seals or Lubricators are not being used, the Precision datum edge on the spacer portion of the Slide may be used for location against a machined register\*4.

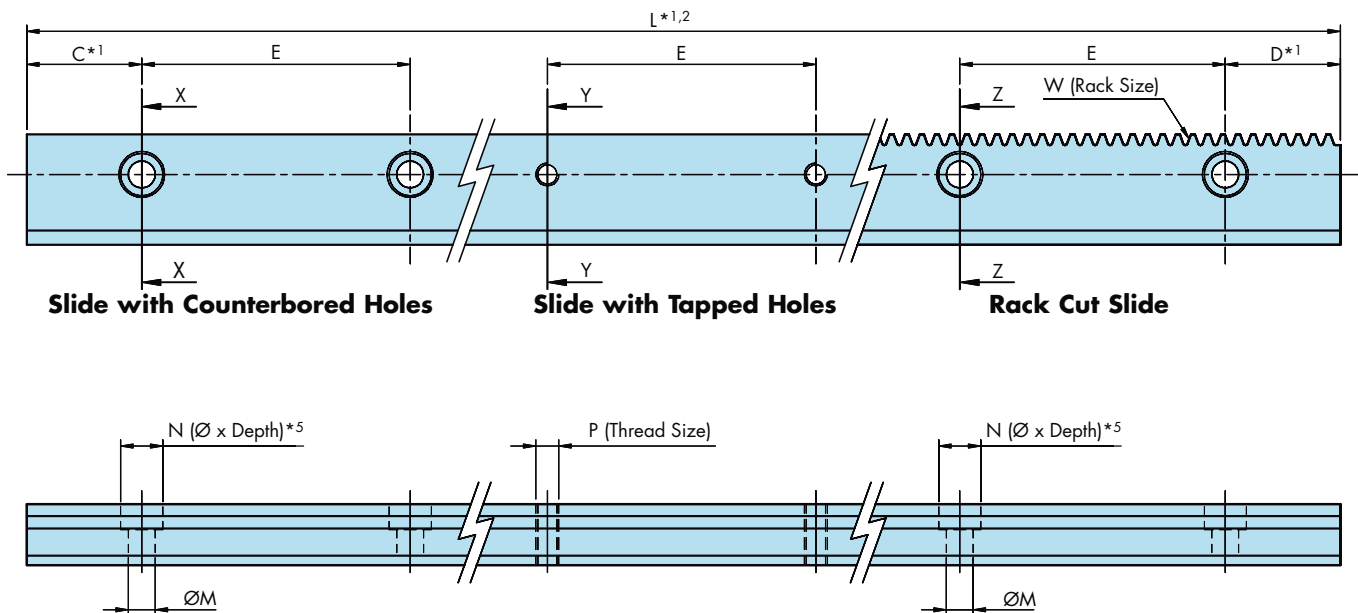

Part Number	Use with Bearings*3		A ~Slide Width	B		B1		C*1	D*1	E ±0.2	F		G		H
	Standard	Slimline		P1 & P2	P3	P1 & P2	P3				P1	P2 & P3	P1	P2 & P3	
NMS E...	...J13...	-	11	11.19	11.71	5	5.3	20.5	20.5	45	3	3.2	6.2	6.4	4
NV E...	...J18...	...J195...	16	16.19	16.72	6.5	6.7	43	43	90	4.21	4.42	8	8.2	4
NS E...	...J25...	...J265...	21	21.37	21.89	8.5	8.7	43	43	90	4.71	4.93	10	10.2	6
NM E...	...J34...	...J360...	29	29.37	29.89	10.5	10.7	43	43	90	6.21	6.42	12.5	12.7	8
NL E...	...J54...	...J580...	43	43.37	43.89	16	16.2	88	88	180	9.21	9.43	19.5	19.7	12

## Notes:

- Any length of Slide within L max dimension can be supplied, but for optimum price and delivery time, Slide lengths should be specified which maintain the C and D dimensions in the table above. In all cases unless otherwise specified by the customer, C and D dimensions will be supplied equal. The position of the teeth on the rack cut versions relative to the mounting holes or Slide ends, will vary. Rack cut Slides with a regulated tooth position can be supplied on request.
- Where Slides longer than the maximum length are required, lengths can be matched suitable for butting. Some sizes of rack cut slides are not always stocked in maximum lengths. In such cases the customer will be offered matched lengths for butting.
- In the table, the preferred choices of [Bearings](#) to use with each slide are quoted. However, other combinations are possible (please see [mix and match](#) page).
- Slides in their free unmounted state are not necessarily absolutely straight. If straightness is important, the slide may be set by bolting down against a register. If Hepco Dowel Pins are used, these should be positioned one each end centrally between the Slide end and first hole and one located centrally between each pair of fixing holes, or as deemed necessary for the application.
- For Slide size NVE, the counterbore diameter 'N' for the rack cut grade has been regulated to suit socket head cap screws DIN 912 with a plain head which has a slightly smaller diameter than those with a knurled finish. This is to maximise the strength between the counterbore and the root of the rack teeth. Suitable screws are available from Hepco if required: Part No. **PFS415** (M4 x 15 long). Customers are advised not to pre-drill fixing holes for these unless they have the means to control their hole positions very accurately.
- The Max Rack Force quoted is that continuous drive force which can be sustained by a well lubricated rack used in conjunction with the appropriate Hepco Pinion.

# Single Edge Spacer Slides



The Single Edge format allows two Slide V's to be mounted wide apart, thus providing a considerable increase in moment load capacity, stiffness and stability. The space between the two Slides can be made sufficient to allow central positioning of the drive, whether by means of ball screw, air cylinder or other type of actuator.

Single Edge Spacer Slides are available with a rack cut into the back face, providing a convenient means of driving. Rack teeth are machined to a high degree of precision and conform to ISO 1328 grade 8. The large face width of the racks makes these the best choice for applications which require high driving forces (see drive [Calculations](#)). Pinions which suit the Racks are also available. Shaft type pinions can be coupled directly to the Hepco Geared [Motor](#) or Gearbox, which can be mounted using the Drive Flange to the customer's own carriage plate.

Although not hardened, the rear face of the Slide is sufficiently durable to act as track for Hepco [Track Rollers](#).

**See Application Examples on pages 13, 14 & 16**

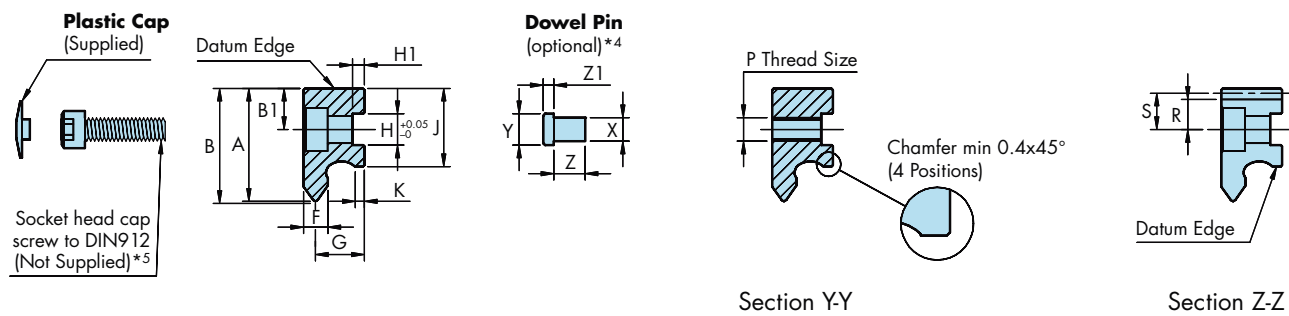

## Available Grades of Slide

✓ Indicates surfaces which are precision ground

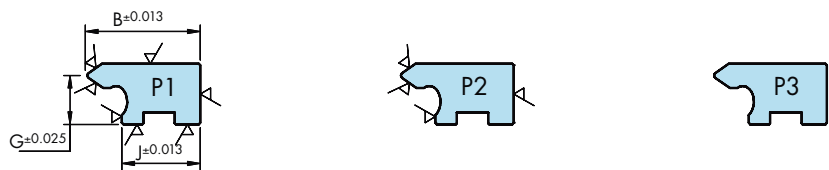

H1	J		K	L Max <sup>+1,2</sup>		M	N <sup>*5</sup>	P	R	S	W	Dowel Pin	X	Y	Z	Z1	Weight	Max Rack Force (N)*6	Part Number
	P1 & P2	P3		P1 & P2	P3														
1.8	9.25	9.65	1.7	1976	4020	3.5	6.2 x 3.1	M3	3.80	4.5	0.5	SDP4	4	4	6.75	-	0.55	180	NMS E...
1.5	12	12.4	1.75	4020	4020	4.5	8 x 4.1	M4	4.82	5.8	0.7	SDP4	4	4	6.75	-	1.0	300	NV E...
2.5	16	16.4	2.6	4020	4020	5.5	10 x 5.1	M5	6.15	7.4	1	SDP6	4	6	6	2.25	1.6	500	NS E...
3	20	20.4	2.3	4020	6000	7	11 x 6.1	M6	7.69	9.25	1.25	SDP8	6	8	8	2.75	2.6	1000	NM E...
4	30	30.4	4.8	4020	6000	11	18 x 10	M10	11.6	14.1	2	SDP12	10	12	15	3.75	6.0	1600	NL E...

## Ordering Details

**NME L930 P1 (R) (T) (C15) (D15)**

Part Number \_\_\_\_\_  
 Slide Length 'L' = **930** mm \_\_\_\_\_  
 Precision grade: options are **P1, P2 & P3** \_\_\_\_\_  
**R** - Rack cut Slide (leave blank if not required) \_\_\_\_\_  
 \_\_\_\_\_ Bespoke values of C & D dimensions Leave blank if standard\*1  
 \_\_\_\_\_ Fixing hole style: **T** - tapped fixing holes  
**N** - no holes, leave blank for counterbored holes

### Example:

1 x N S E L2066 P3 N \_\_\_\_\_ Single Edge Spacer Slide in precision grade 3, 2066 mm long with no holes.  
 24 x SDP6 \_\_\_\_\_ 6 mm Ø head dowel pins (optional).

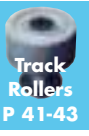
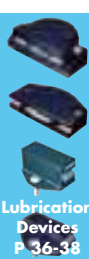
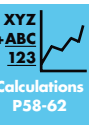
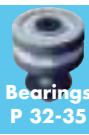

# Double Edge Flat Slides

Hepco Double Edge Flat Slides are available in a range of 11 sizes corresponding to those of the [Double Edge Spacer Slides](#). Single Edge Flat Slides are also available in 5 complementary sections. All Flat Slides come in 3 grades of precision and are zone hardened on the 'V' edges to provide an extremely hard wearing surface. Grades P1 and P2 are precision ground on V and opposing faces to a high degree of accuracy and parallelism with P1 being ground on the mounting surfaces as well\*<sup>4</sup>. The unground version P3 is also sufficiently accurate for many applications (please see [System Selector](#) for comparative data).

Flat Slides are supplied with plain fixing holes as standard and with counterbored holes to suit low head cap screws as an option. Unground grade P3 slides are available without holes if preferred. The counterbored option is necessary if the Double Edge Flat Slides are used in conjunction with [Belt Driven Carriages](#) in order to provide an uninterrupted path for the belt. Also, where there is insufficient room between slide and carriage plate for a conventional screw head (possible in "Mix and Match" situations or where customer's own flat carriage plates are used in conjunction with Slimline [Bearings](#)).

The Slide fixing holes are accurately positioned, allowing customers to pre-drill their mounting holes. All Hepco Flat Slides are

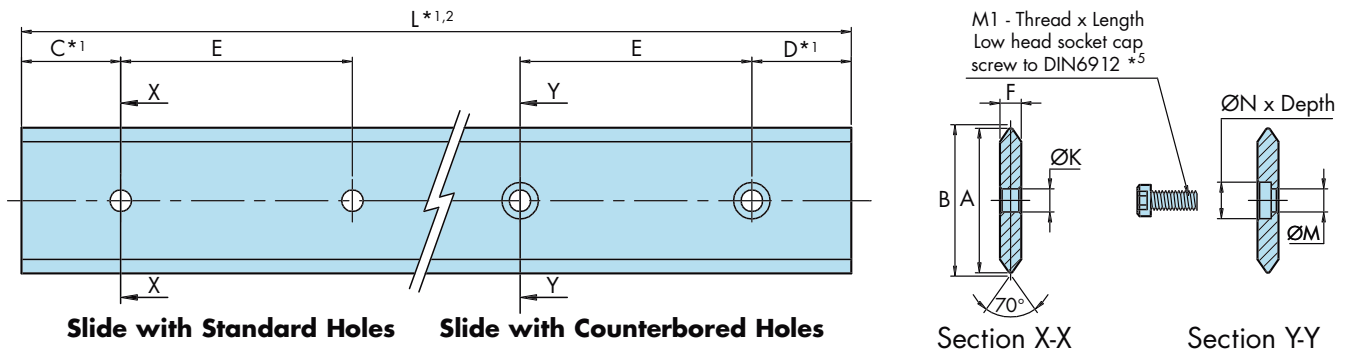

## Available Grades of Slide

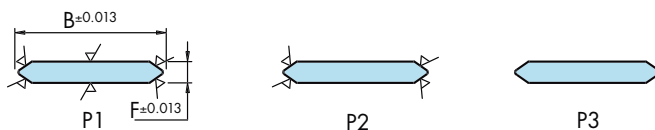

✓ Indicates surfaces which are precision ground

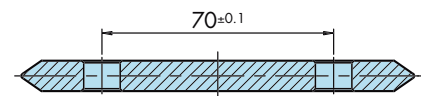

The L120 section has 2 rows of holes

Part Number		Use With Bearings * <sup>3</sup>		A ~Slide Width	B		C	D	E ±0.2	F	
Double Edge	Single Edge	Standard	Slimline		P1 & P2	P3				P1	P2 & P3
MS 12...		...J13...	-	12	12.55	13.13	13	13	30	3.05	3.2
	MS E...	...J13...	-	-	-	-	20.5	20.5	45	3.05	3.2
V 20...		...J18...	...J195...	20	20.37	21.01	43	43	90	4.27	4.42
V 28...		...J18...	...J195...	28	28.37	29.01	43	43	90	4.27	4.42
	V E...	...J18...	...J195...	-	-	-	43	43	90	4.27	4.42
S 25...		...J25...	...J265...	25	25.81	26.58	43	43	90	4.78	4.93
S 35...		...J25...	...J265...	35	35.81	36.58	43	43	90	4.78	4.93
S 50...		...J25...	...J265...	50	50.82	51.58	43	43	90	4.78	4.93
	S E...	...J25...	...J265...	-	-	-	43	43	90	4.78	4.93
M 44...		...J34...	...J360...	44	44.81	45.58	43	43	90	6.28	6.42
M 60...		...J34...	...J360...	60	60.81	61.58	43	43	90	6.28	6.42
M 76...		...J34...	...J360...	76	76.81	77.58	43	43	90	6.12	6.42
	M E...	...J34...	...J360...	-	-	-	43	43	90	6.28	6.42
L 76...		...J54...	...J580...	76	76.81	77.58	43	43	90	9.12	9.43
L 120...		...J54...	...J580...	120	120.81	121.58	88	88	180	9.12	9.43
	L E...	...J54...	...J580...	-	-	-	43	43	90	9.12	9.43

## \*Notes:

- Any length of Slide within L max dimension can be supplied, but for optimum price and delivery time, Slide lengths should be specified which maintain the C and D dimensions in the table above. In all cases unless otherwise specified by the customer, C and D dimensions will be supplied equal.
- Where Slides longer than the maximum length are required, lengths can be matched suitable for butting.
- In the table, the preferred choices of [Bearings](#) to use with each Slide are quoted. However, other combinations are possible (please see [mix and match](#) page).
- Slides in their free unmounted state are not necessarily absolutely straight. If important, the Slide should be set straight by bolting down to a register.
- Counterbored holes for Flat Slides are designed to suit socket cap head screws DIN 6912. These screws are not universally stocked, so Hepco offers them as a convenience to customers in a single length for each thread size (see table).



# Single Edge Flat Slides

left 'soft' outside the area of the V's to allow subsequent machining if required.

Flat Slides are useful where weight saving or minimum inertia is required in cases where the slide is the moving component. Also, where it is practical to design a support profile as an integral part of the machine to provide running clearance for the [Bearings](#) and [Lubrication Devices](#).

The Single Edged format allows two Slide V's to be mounted wide apart, thus providing a considerable increase in moment load capacity, stiffness and stability. The space between the two slides can be made sufficient to allow central positioning of the drive whether by means of ball screw, air cylinder or other types of actuator.

Single Edge Flat Slides can be attached to commonly available square and rectangular hollow section material by means of tapped hexagonal bar to achieve a low cost, high strength structure complete with linear guide (see page 8).

**See Application Examples on pages 8, 9, 11, 13 & 14**

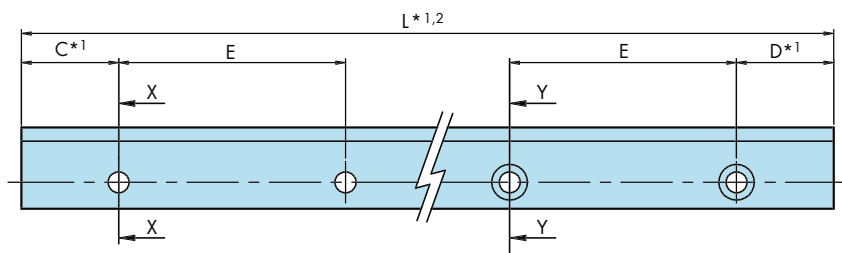

**Slide with Standard Holes    Slide with Counterbored Holes**

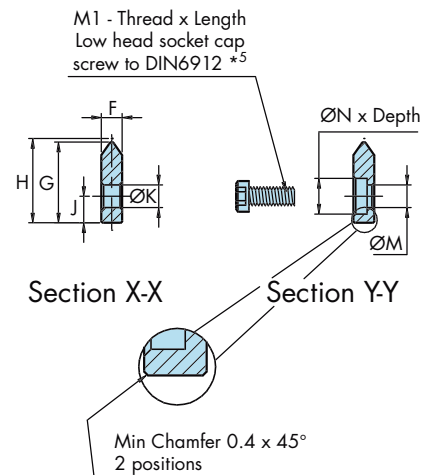

## Available Grades of Slide

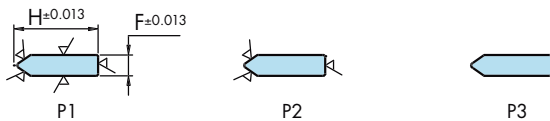

✓ Indicates surfaces which are precision ground

	G ~Slide Width	H			J		K		L Max		M	M1 *5		N Ø x Depth	Weight kg/m	
		P1 & P2	P3	P1 & P2	P3	Ø	Screw Size	P1 & P2	P3	Screw Size		Part No.	Double Edge		Single Edge	
	-	-	-	-	-	3.5	M3	1000	1976	-	-	-	-	-	0.23	-
	11	11.37	11.8	4.5	4.7	3.5	M3	1000	1976	-	-	-	-	-	-	0.22
	-	-	-	-	-	4.5	M4	4020	4020	4.5	M4 x 10	FS410	8 x 2.8	0.6	-	-
	-	-	-	-	-	5.5	M5	4020	4020	4.5	M4 x 10	FS410	8 x 2.8	0.9	-	-
	16	16.37	16.8	6	6.2	4.5	M4	4020	5500	4.5	M4 x 10	FS410	8 x 2.8	-	0.5	-
	-	-	-	-	-	7	M6	4020	6000	5.5	M5 x 10	FS510	10 x 3.5	0.8	-	-
	-	-	-	-	-	7	M6	4020	6000	5.5	M5 x 10	FS510	10 x 3.5	1.3	-	-
	-	-	-	-	-	7	M6	4020	6000	5.5	M5 x 10	FS510	10 x 3.5	1.7	-	-
	19	19.46	20.0	6.5	6.7	5.5	M5	4020	5500	5.5	M5 x 10	FS510	10 x 3.5	-	0.7	-
	-	-	-	-	-	7	M6	4020	6000	7	M6 x 12	FS612	11 x 4	1.9	-	-
	-	-	-	-	-	9	M8	4020	6000	7	M6 x 12	FS612	11 x 4	2.7	-	-
	-	-	-	-	-	9	M8	4020	6000	7	M6 x 12	FS612	11 x 4	3.4	-	-
	25	25.46	26.0	8	8.2	7	M6	4020	6000	7	M6 x 12	FS612	11 x 4	-	1.2	-
	-	-	-	-	-	11.5	M10	4020	6000	11.5	M10 x 20	FS1020	18 x 6	5	-	-
	-	-	-	-	-	11.5	M10	4020	6000	11.5	M10 x 20	FS1020	18 x 6	8.5	-	-
	32	32.46	33.0	10	10.2	9	M8	4020	6000	9	M8 x 20	FS820	15 x 6	-	2.2	-

## Ordering Details

**M60 L930 P1 (C) (C15) (D15)**

Part Number \_\_\_\_\_ Bespoke values of 'C' & 'D' dimensions in mm  
 Slide Length 'L' = **930** mm \_\_\_\_\_ Leave blank if standard \*1  
 Precision grade: options are **P1, P2 & P3** \_\_\_\_\_ Fixing hole options are:  
**C** - counterbored holes (not available on MS12 & MSE)  
**N** - no holes (P3 grade only), leave blank for plain holes

### Example:

1 x LE 2156 P3 C \_\_\_\_\_ Single Edge Flat Slide x 2156 mm long in unground grade 3 with counterbored holes.  
 24 x FS820 \_\_\_\_\_ Low head socket cap screws M8 thread x 20 mm long (optional).

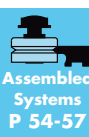

# Slide Beams

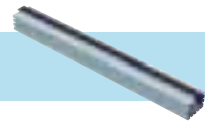

The Hepco Slide Beam consists of a Flat Slide mounted onto a precision, anodised aluminium extrusion to provide a rigid self-supporting beam which can form an integral part of a machine structure (refer slide deflection [calculations](#)). There are two basic sizes of beam, each available with a number of different Slide widths to cater for customer's space and moment load requirements. The smaller size Beam is available as a lightweight version, this reduces inertia where the Slide Beam is to be used dynamically. All Slide Beams can be supplied in lengths of up to 8 metres in one piece\*<sup>1,3</sup> and are compatible with all Hepco [Bearings](#), [Carriages](#) and [Lubrication Devices](#). Slides can be specified in any of the three grades of precision available depending upon the requirements for cost, accuracy and performance (see [System Selector](#)).

Customers contemplating driving by means of a belt, steel band, cable or chain, will benefit from the large hollow centre which can be used for routing the return. If drive by timing belt is required, please consider the Hepco [Belt Driven Carriage](#) which has been specifically designed for such application. This will require the counterbored screw fixing option

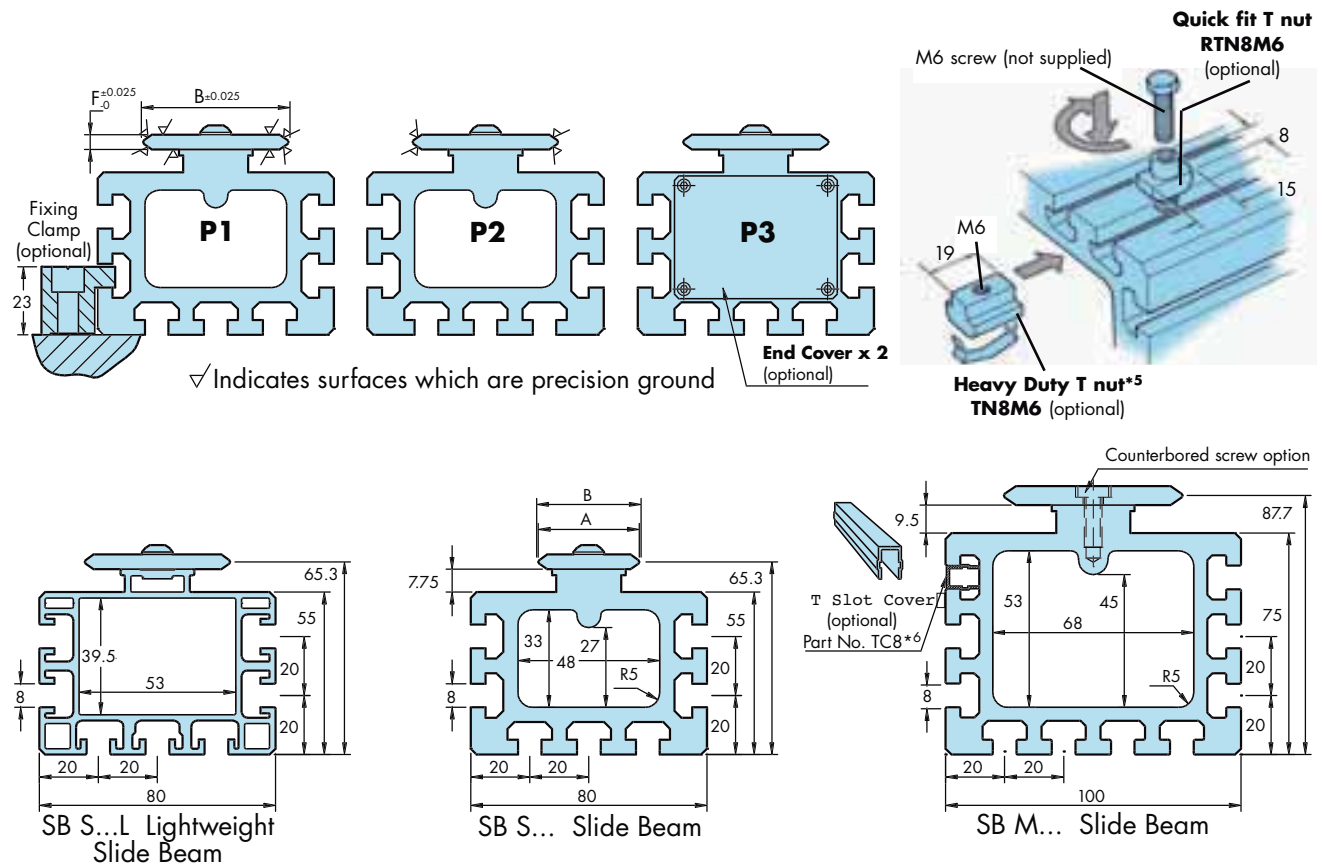

Part Number	Use With Carriages* <sup>4</sup>			A ~Slide Width	B		C* <sup>2</sup>	D* <sup>2</sup>	E	F	
	Standard	Slimline	Belt Drive		P1 & P2	P3				P1	P1 & P2
SB S 35...	AU 35 25...	AU 35 265...	AU BD 35 25...	35	35.81	36.58	43	43	90	4.77	5
SB S 50...	AU 50 25...	AU 50 265...	AU BD 50 25...	50	50.81	51.58	43	43	90	4.77	5
SB M 44...	AU 44 34...	AU 44 360...	AU BD 44 34...	44	44.81	45.58	43	43	90	6.27	6.5
SB M 60...	AU 60 34...	AU 60 360...	AU BD 60 34...	60	60.81	61.58	43	43	90	6.27	6.5
SB M 76...	AU 76 34...	AU 76 360...	AU BD 76 34...	76	76.81	77.58	43	43	90	6.10	6.5

## Notes:

- Beams longer than 4020 mm (6000 mm for P3 grade) will be supplied with two or more lengths of matched Slide each mounted and doweled to form a precision joint. Additional fixing screws will normally be provided adjacent to each joint. Slide Beams with shorter slides fixed in any position, can be supplied upon request.
- For optimum price and delivery time, Slide Beam lengths should be specified which maintain the C and D dimensions in the table above. In all cases unless otherwise specified by the customer, C and D dimensions will be supplied equal.
- For requirements in excess of 8 m, Slide Beams can be supplied matched ready for joining. Please contact Hepco for details.
- In the table, the available choices of Carriage to use with each Slide Beam are quoted. However, it is possible to use a customer made carriage incorporating other sizes of Bearings (please see details of "mix and match" possibilities).
- The Heavy Duty T nut is recommended for the Lightweight Beam and where greater security of fixing is required. T nut section is also available in undrilled lengths up to 3000 mm. Please specify part number **TN8S** followed by the required length in mm.
- The T slot cover is made from black UPVC and is available in lengths up to 8000 mm. Please specify part number **TC8** followed by the required length in mm.

# Slide Beams

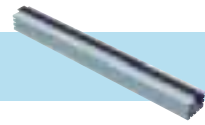

to be specified for the Slide in order to provide a flush running surface for the belt. The counterbored screw fixing option will also be required where there is insufficient room between Slide and Carriage plate for screw heads (possible in "Mix and Match" situations or where customer's own flat carriage plates are used in conjunction with Slimline Bearings).

For customers requiring a belt driven system complete with end pulley units, Hepco recommend their standard range of **Driven Linear Systems**, details of which may be found in the comprehensive Hepco **DLS** catalogue. Also included in the DLS catalogue are compatible motors, gearboxes and switching equipment, all of which may be suitable for customers carrying out their own designs using the Hepco Slide Beam.

**See Application Examples on page 12**

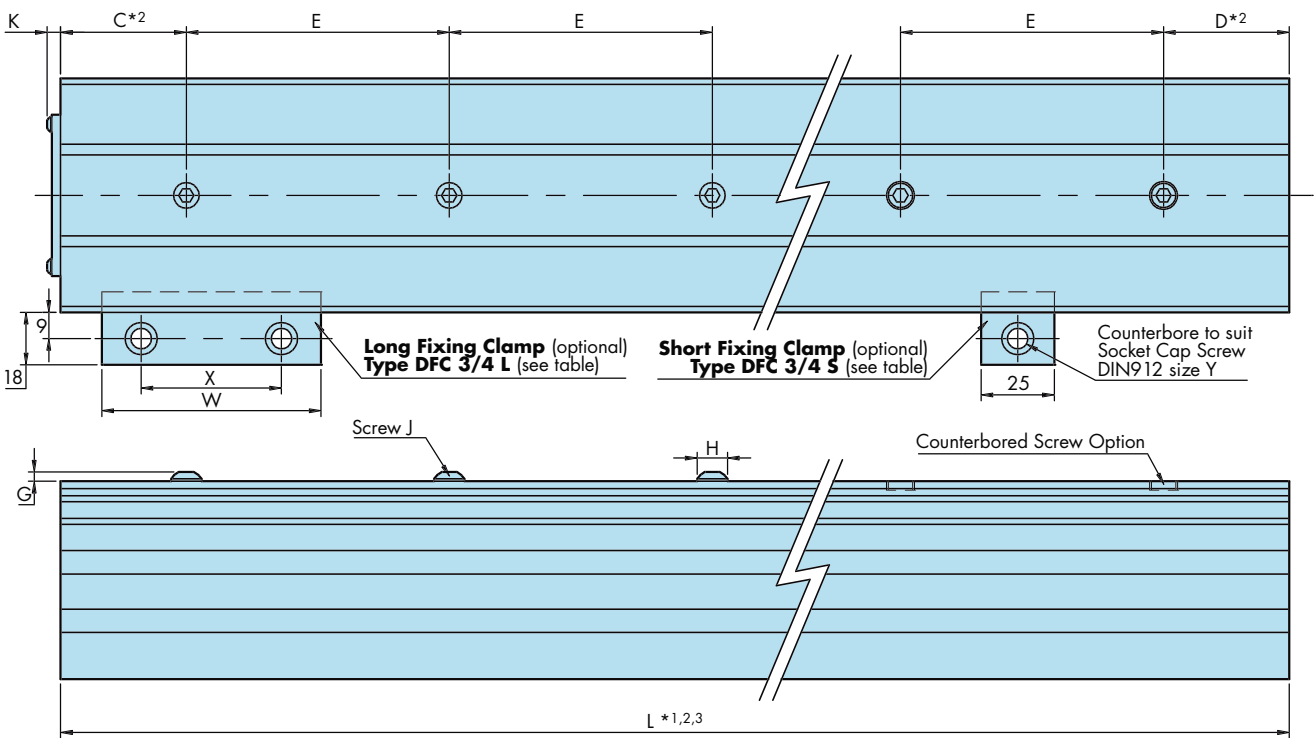

G	H	J		K	L Max *1,2,3	Fixing Clamps		W	X	Y	Weight kg/m		Part Number
		Standard	C/Bored			Short	Long				Std beam	Light beam	
3.3	10.5	M6	M5	5.5	8000	DFC3S	DFC3L	75	48	M6	6	4.3	SB S 35...
3.3	10.5	M6	M5	5.5	8000	DFC3S	DFC3L	75	48	M6	6.5	4.7	SB S 50...
3.3	10.5	M6	M6	5.5	8000	DFC4S	DFC4L	100	65	M8	10	-	SB M 44...
4.4	14	M8	M6	5.5	8000	DFC4S	DFC4L	100	65	M8	11	-	SB M 60...
4.4	14	M8	M6	5.5	8000	DFC4S	DFC4L	100	65	M8	11.5	-	SB M 76...

## Ordering Details

**SBS35 L1346 P1 (L) (C) (X) (C33) (D53)**

Part Number **SBS35**  
 Beam Length 'L' = **1346** mm  
 Precision grade: options are **P1, P2 & P3**  
**L** - Lightweight beam option (leave blank if not required)  
**C** - Counterbored screw fixing option (leave blank if not required)  
**X** - End cover option (leave blank if not required)  
**C** - Counterbored screw fixing option (leave blank if not required)  
 Bespoke values of C & D dimensions in mm - Leave blank if standard\*2

## Ancillary Items:

See drawing for the part numbers relating to T nuts\*5, T Slot Cover \*6 and Fixing Clamps.

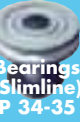

# Standard Bearings



All Hepco Standard Bearings are compatible with all grades of Slide and although designed to be used with particular sizes of slide, may be "mixed and matched" in many instances. The following Bearing formats and fixing methods may be chosen to cater for most design requirements.

**The Twin Bearing type**  which is the default choice, comprises two individual deep groove ball bearings on a single stud. This construction offers some compliance allowing smoother running, easy adjustment and greater tolerance of misalignment.

**The Double Row Bearing type (DR)**  incorporates a one-piece bearing with two ball tracks. This offers higher load capacity, especially in the radial direction and is less susceptible to entrapment of debris.

Both types of bearing have been designed specially for Slide system applications and their performance confirmed by rigorous testing. External dimensions are identical.

**The Nitrile Sealed option (NS)** available for both bearing formats, provides a higher degree of sealing against ingress of water or debris than does the default metal shielded type. A small increase in friction may result.

**The Through Hole Fixing type** is available in two stud lengths covering most thicknesses of carriage or mounting plate, the short stud version being compatible with the Hepco Carriage plates. Both versions are available in **Concentric type (C)**

## Through Fixing Type (SJ/LJ)

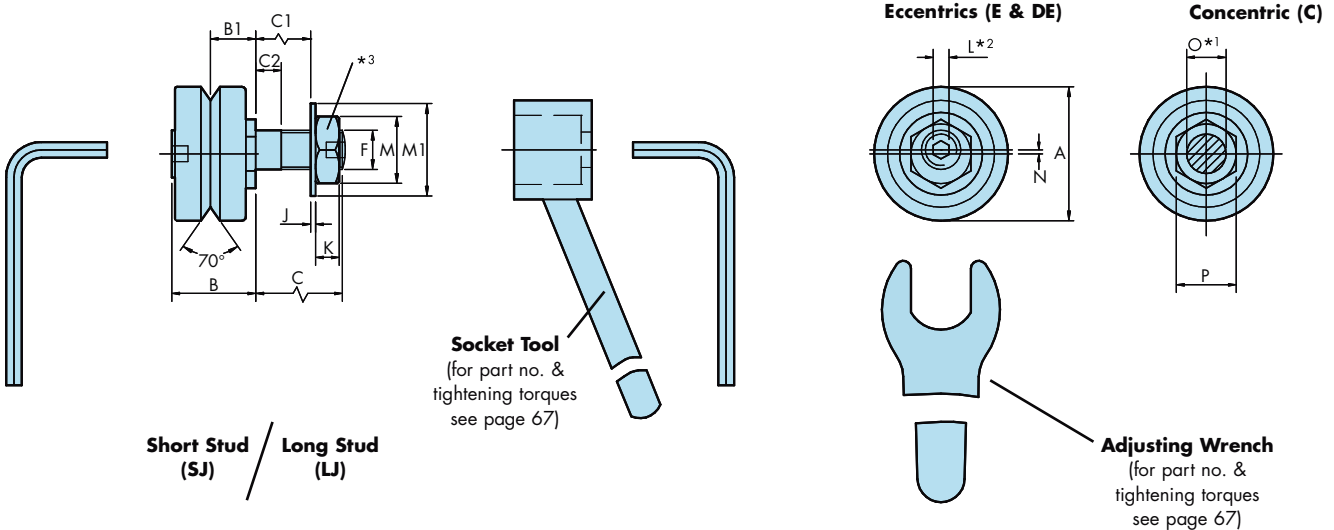

Part Number	Use With Slide Section* <sup>9</sup>	A	B	±0.025 B1	C		C1		C2		±0.025 D	D1
					Short Stud	Long Stud	Short Stud	Long Stud	Short Stud	Long Stud		
... J 13 ...	MS & NMS	12.7	10.1	5.47	5.8	9.5	3	6.7	2.2	2.4	9.51	4.76
... J 18 ...	V & NV	18	12.4	6.75	7.4	14	3.4	10	2.4	2.5	14.0	7.0
... J 25 ...	S & NS	25	16.6	9	9.8	19	3.8	13	3.4	4.9	20.27	10.13
... J 34 ...	M & NM	34	21.3	11.5	13.8	22	6.6	14.8	5.2	5.9	27.13	13.56
... J 54 ...	L & NL	54	34.7	19	17.8	30	8.2	20.4	5.7	7.9	41.76	20.88

S1	T	T1	T2	±0.1 U	U1	V	W	X	Y	Z	Weight ~g			
											SJ...	LJ...	BHJ...C	BHJ...E
6.6	8.5	3.75	6.75	30	47.5	8	20	M3	5.5	8	8	8	7	27
10.5	10	4	8	38	54	11	24.5	M4	7	7	19	20	18	45
9	12	5	10	50	72	14	32	M5	8.5	10	48	51	43	105
8.5	17.5	6.5	12.5	60	90.5	17	42	M6	10	14	115	120	105	235
16.4	23.5	10.5	18.5	89.5	133	25	62	M8	13	20	415	425	390	800

### Notes:

- It is recommended that holes to suit Bearing mounting studs should be reamed to tolerance F6 for a sliding fit.
- All eccentric Through Fixing type Bearing studs are supplied with sockets for adjustment as shown, with the exception of size 13.
- Nuts for the Through Fixing type Bearings are chemically blacked on the concentric version and bright zinc plated on the eccentrics for identification purposes.
- 'R' dimension is both the eccentric offset of the adjusting nut and the total adjustment available at the bearing centre line for 360° rotation of the adjusting nut.
- Double Eccentric Bearings require different mounting hole centres (please see page 20, dimension H1).
- The Blind Hole eccentric Bearings cannot be fitted with Cap Seals, however Lubricators may be specified instead.
- Controlled Height Bearings are selected within ±0.005 mm in respect of B1 dimension compared to the normal tolerance of ±0.025 mm. They are supplied in sets of up to eight Bearings within the same tolerance band. Larger quantities of Bearings within the same tolerance band are available on request.
- The quoted static and dynamic load capacities are based on industry standard calculations. These do not accurately reflect system performance, and are only provided for comparison with other systems. Please use the Max Working Load figures and the load/life calculations on pages 58-61 to determine system performance.
- The preferred Slide choices for each Bearing are listed. Other Slides may be used as shown in the Mix & Match tables.

# Standard Bearings



which are fixed, **Eccentric type (E)**, adjustable and **Double Eccentric type (DE)**\*<sup>5</sup> which have sufficient adjustment to enable a carriage to be disengaged from the Slide (see application drawing on page 8).

All *Through Hole* Fixing types are available in a **Controlled Height version (CH)**\*<sup>7</sup> which minimises variation between Bearings in respect of the important 'B1' dimension. This may be desirable in some high precision applications.

**The Blind Hole Fixing type (BH)** allows mounting into a solid machine base where through mounting holes are not possible, or where the thickness of the mounting plate is too great (see application drawings on page 16). The Blind Hole Fixing type is also useful where adjustment from the front is preferred or where access to the opposite side of the mounting hole is restricted. They are available in **Concentric type (C)** which are fixed, or **Eccentric type (E)**\*<sup>6</sup> which are adjustable.

All Bearings are greased for life internally. Customers are strongly recommended to provide lubrication to the interface between Bearings and *Slide* by specifying Hepco **Cap Seals** which fit over the bearings, or by using Hepco **Lubricators**. Lubrication greatly increases load capacity and life.

**See Application Examples on pages 8-16**

## Blind Hole Fixing Type (BHJ)

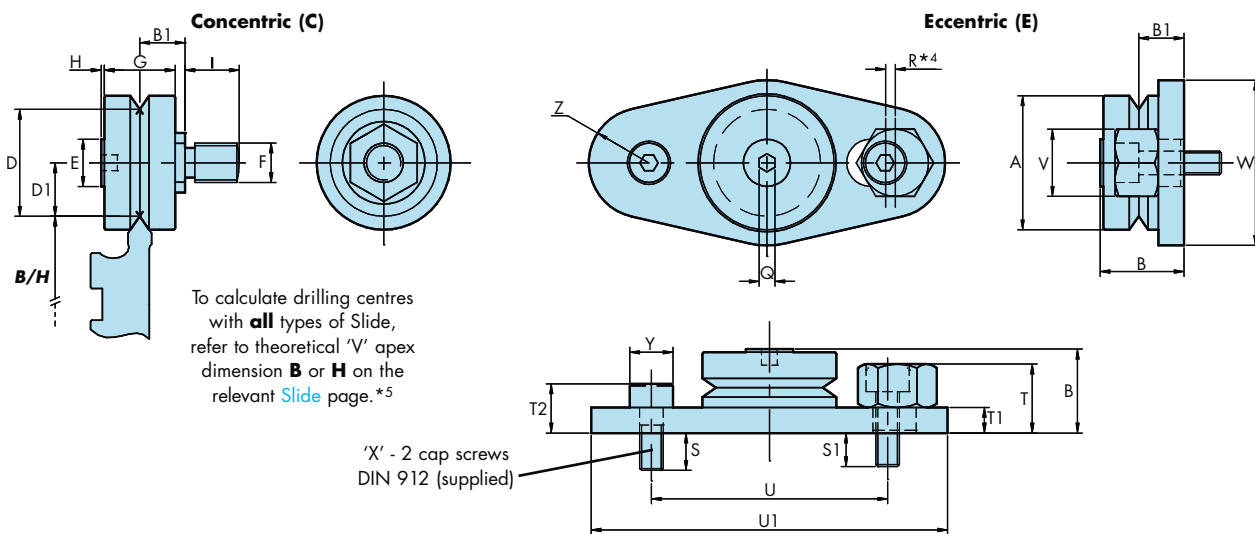

	E	F Metric Fine	G	H	I	J	K	L* <sup>2</sup>	M	M1	N		+0 -0.03 O* <sup>1</sup>	P	Q	R* <sup>4</sup>	S
											...E...	...DE...* <sup>5</sup>					
	5	M4 x 0.5	8	0.5	5.8	0.8	2.2	-	7	9	0.5	1.9	4	7	1.5	1.0	6.25
	7	M6 x 0.75	10	0.6	7.4	0.8	3.2	2.5	10	13	0.7	2.6	6	11	2	1.2	8
	10	M8 x 1	14	0.5	9.8	1	5	3	13	17	0.75	2.75	8	13	3	1.5	7
	12	M10 x 1.25	18	0.7	13.8	1.25	6	4	17	21	1	3.6	10	15	4	2.0	9.5
	25	M14 x 1.5	28	1.6	17.8	1.6	8	6	22	28	1.5	5.5	14	27	8	3.0	14.5

	Max Working Load Capacities (N)				Bearing Static (Co) and Dynamic (C) Load Capacities (N)* <sup>8</sup>							
	Double Row Bearings		Twin Bearings		For Double Row Bearings				For each of two Twin Bearings			
	Radial	Axial	Radial	Axial	Radial Loads		Axial Loads		Radial Loads		Axial Loads	
					Co	C	Co	C	Co	C	Co	C
	-	-	120	60	-	-	-	-	265	695	74	194
	600	190	200	125	1168	2301	435	857	593	1438	173	419
	1500	400	600	320	2646	5214	821	1618	1333	3237	326	791
	3000	900	1400	800	5018	9293	1362	2523	2600	5291	557	1270
	5000	2500	3200	1800	12899	21373	2777	4601	6657	13595	1136	2320

Part Number	Options Available				
	- Metal Shields	NS Nitrile Seals	- Twin Bearings	DR Double Row Bearings	CH Controlled Height
... J 13 ...	X	✓	✓	X	✓
... J 18 ...	X	✓	✓	✓	✓
... J 25 ...	✓	✓	✓	✓	✓
... J 34 ...	✓	✓	✓	✓	✓
... J54 ...	✓	✓	✓	✓	✓

## Ordering Details

Fixing type. Choose from:

**SJ** = Short Stud, **LJ** = Long Stud

& **BHJ** = Blind Hole Fixing

Part Number (~ Bearing Diameter in mm)

**C** = Concentric (fixed), **E** = Eccentric (adjustable)

or **DE** = Double Eccentric (for disengagement purposes)

**LJ 25 C (DR) (NS) (CH)**

**Controlled Height**\*<sup>7</sup>

Leave blank if not required

**Nitrile Sealed** Bearing

Leave blank if metal shields are required

**Double Row** Bearing

Leave blank if **Twin Bearing** is required

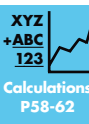
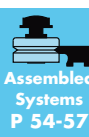

# Slimline Bearings



Hepco Slimline Bearings are very compact due to the single ball track design. Good rigidity is maintained by a combination of ball to raceway conformity and low radial clearance resulting in a low cost bearing ideally suited to many slide system applications. Performance of these Bearings has been confirmed by rigorous testing.

Slimline Bearings are compatible with all grades of [slide](#) and although designed to be used with particular sizes of Slide, may be "mixed and matched" in many instances.

The following options and fixing methods may be chosen to cater for most design requirements.

The **Nitrile Sealed option (NS)** provides a higher degree of sealing against ingress of water or debris than does the default metal shielded type although a small increase in friction may result.

The **Through Hole Fixing type** is available in two stud lengths covering most thicknesses of carriage or mounting plate, the short stud version being compatible with the Hepco [Slimline Carriage](#) Plates. Both versions are available in **Concentric**

## Through Fixing Type (GSJ/GLJ)

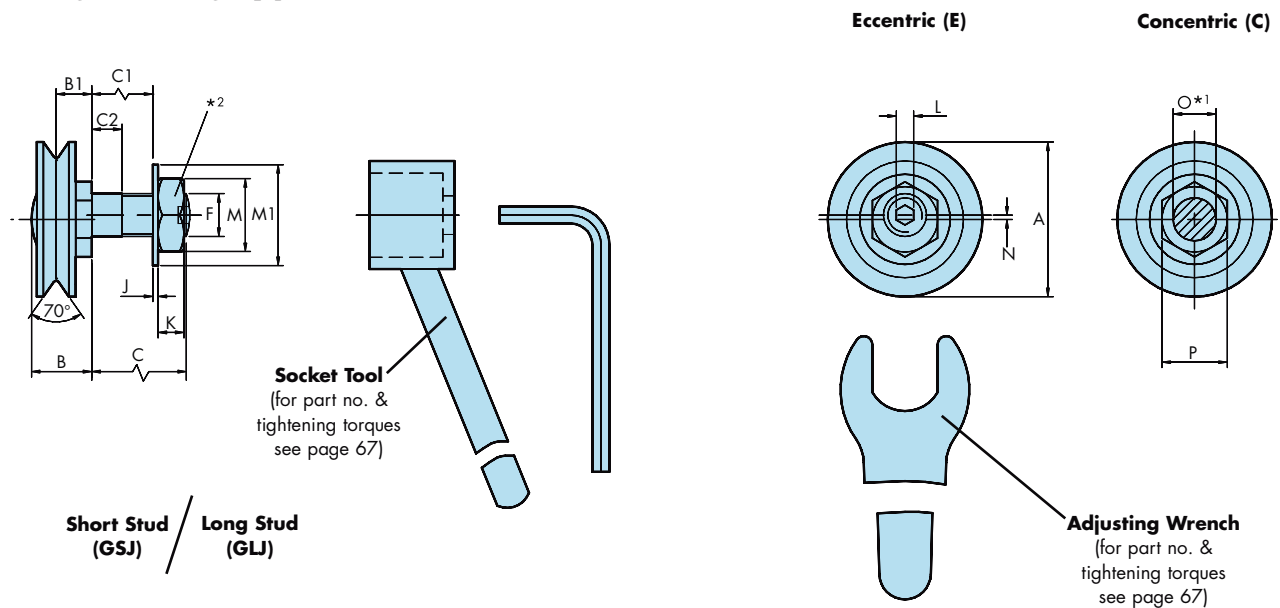

Part Number	Use With Slide Section*6	A	B	±0.025 B1	C		C1		C2		D	D1
					Short Stud	Long Stud	Short Stud	Long Stud	Short Stud	Long Stud		
... J 195 ...	V & NV	19.5	9.2	5.7	7.4	14	3.4	10	2.4	2.5	14.8	7.4
... J 265 ...	S & NS	26.5	11.3	6.8	9.8	19	3.8	13	3.4	4.9	19.98	9.99
... J 360 ...	M & NM	36	14	8.3	13.8	22	6.6	14.8	5.2	5.9	27.57	13.79
... J 580 ...	L & NL	58	22.8	14.3	17.8	30	8.2	20.4	5.7	7.9	46.08	23.04

R*3	S	S1	T	T1	T2	T3	±0.1 U	U1	V	W	X	Y	Z
1.2	8	10.5	8.6	4	8	2.8	38	54	11	24.5	M4	7	7
1.5	7	9	11	5	10	3.6	50	72	14	32	M5	8.5	10
2	9.5	11.3	13.3	6.5	12.5	4.3	60	90.5	17	42	M6	10	14
3	14.5	16.4	21.9	10.5	18.5	8.6	89.5	133	25	62	M8	13	20

### Notes:

1. It is recommended that holes to suit Bearing mounting studs should be reamed to tolerance F6 for a sliding fit.
2. Nuts for the Through Fixing type Bearings are chemically blacked on the concentric version and bright zinc plated on the eccentrics for identification purposes.
3. 'R' dimension is both the eccentric offset of the adjusting nut and the total adjustment available at the bearing centre line for 360° rotation of the adjusting nut.
4. The Blind Hole eccentric Bearings cannot be fitted with [Cap Wipers](#), however [Lubricators](#) may be specified instead.
5. The quoted static and dynamic load capacities are based on industry standard calculations. These do not accurately reflect system performance, and are only provided for comparison with other systems. Please use the Max Working Load figures and the load/life [calculations](#) on pages 58-61 to determine system performance.
6. The preferred [Slide](#) choices for each Bearing are listed. Other Slides may be used as shown in the [Mix & Match](#) tables.

# Slimline Bearings



**type (C)** which are fixed and **Eccentric type (E)** which are adjustable.

**The Blind Hole Fixing type (GBH)** allows mounting into a solid machine base where through mounting holes are not possible, or where the thickness of the mounting plate is too great (see application drawing on page 16). The Blind Hole Fixing type is also useful where adjustment from the front is preferred or where access to the opposite side of the mounting hole is restricted. They are available in **Concentric type (C)** which are fixed, or **Eccentric type (E)** which are adjustable\*4.

All Bearings are greased for life internally. Customers are strongly recommended to provide lubrication to the interface between Bearings and slide by specifying Hepco **Cap Wipers** which fit over the bearings, or by using Hepco Slimline **Lubricators**. Lubrication greatly increases load capacity and life.

**See Application Examples on pages 8-10, 13 & 16**

## Blind Hole Fixing Type (GBHJ)

**Concentric (C)**

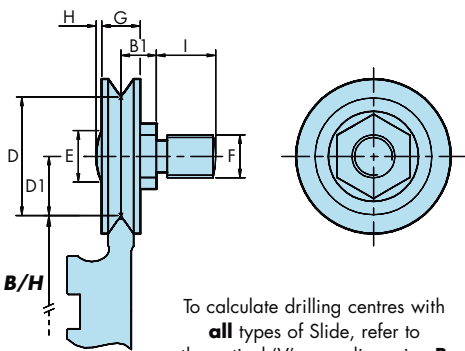

**Eccentric (E)**

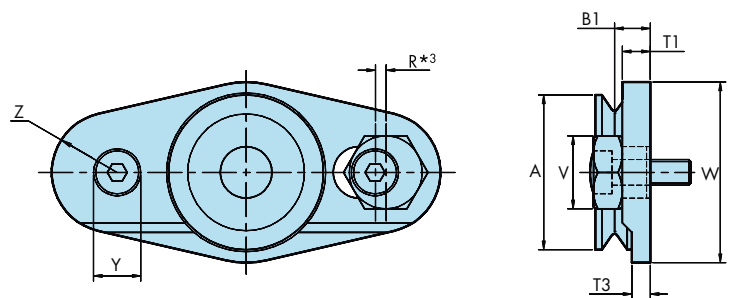

To calculate drilling centres with **all** types of Slide, refer to theoretical 'V' apex dimension **B** or **H** on the relevant **Slide** page.

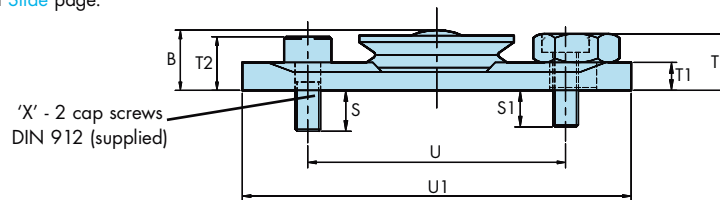

**Assembled Systems**  
P 54-57

**XYZ +ABC 123**  
Calculations  
P58-62

**Cap Wiper**  
P 37

**Lubricator**  
P 38

**Mix & Match Options**  
P 54

**Slides**  
P24-31

**Slimline Carriages**  
P 22-23

**System Selector**  
P 17

	<b>E</b>	<b>F</b> Metric Fine	<b>G</b>	<b>H</b>	<b>I</b>	<b>J</b>	<b>K</b>	<b>L</b>	<b>M</b>	<b>M1</b>	<b>N</b>	$\begin{smallmatrix} +0 \\ -0.03 \\ O^{+1} \end{smallmatrix}$	<b>P</b>
	7	M6 x 0.75	5	1	7.4	0.8	3.2	2.5	10	13	0.7	6	11
	10	M8 x 1	7	1	9.8	1	5	3	13	17	0.75	8	13
	12	M10 x 1.25	9	1.2	13.8	1.25	6	4	17	21	1	10	15
	23.5	M14 x 1.5	14	1.5	17.8	1.6	8	6	22	28	1.5	14	27

Weight ~g			
<b>GSJ...</b>	<b>GLJ...</b>	<b>GBHJ...C</b>	<b>GBHJ...E</b>
14	16	13	40
28	30	23	85
65	70	55	185
280	290	255	660

Max Working Load Capacities		Static (Co) and Dynamic (C) Load Capacities (N) *5			
		Radial Loads		Axial Loads	
		Co	C	Co	C
240	100	563	1366	164	398
575	235	1267	3075	310	751
1200	500	2470	5625	530	1206
2600	1060	6324	12915	1079	2204

Part Number	Options Available	
	- Metal Shields	NS Nitrile Seals
... J 195 ...	X	✓
... J 265 ...	✓	✓
... J 360 ...	✓	✓
... J 580 ...	✓	✓

## Ordering Details

**GLJ 265 C (NS)**

Fixing type. Choose from: \_\_\_\_\_

**GSJ** = Short Stud, **GLJ** = Long Stud

& **GBHJ** = Blind Hole Fixing

Part Number (~10x Bearing Diameter in mm) \_\_\_\_\_

\_\_\_\_\_ **Nitrile Sealed Bearings**

Leave blank if metal shields are required

**C** = Concentric (fixed), **E** = Eccentric (adjustable)

# Cap Seals

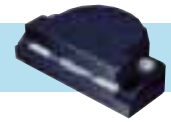

Flexible plastic Cap Seals fit over individual Standard Bearings, providing effective sealing and protection, plus wiping of debris from the Slide profile. Lubrication of the 'V' surface is provided by means of oil-impregnated felt wipers.

The internal cavity is filled with grease via the lubrication points, further improving lubrication and recharging the felt wipers as the grease partially liquefies under operation. Most systems require no further lubrication during the lifetime of the machine\*<sup>3</sup>. Fitment of these seals increases load, life and linear speed capability as well as improving operator safety.

Cap Seals are not available for use with size 12 Bearings.



Assembled Systems  
P 54-57

Bearings (Standard)  
P 32-33

XYZ +ABC  
123  
Calculations  
P58-62

Mix & Match  
Options  
P 54

Slides  
P 24-31

System Selector  
P 17

**See Application Examples on pages 9, 10, 12, 13, & 14**

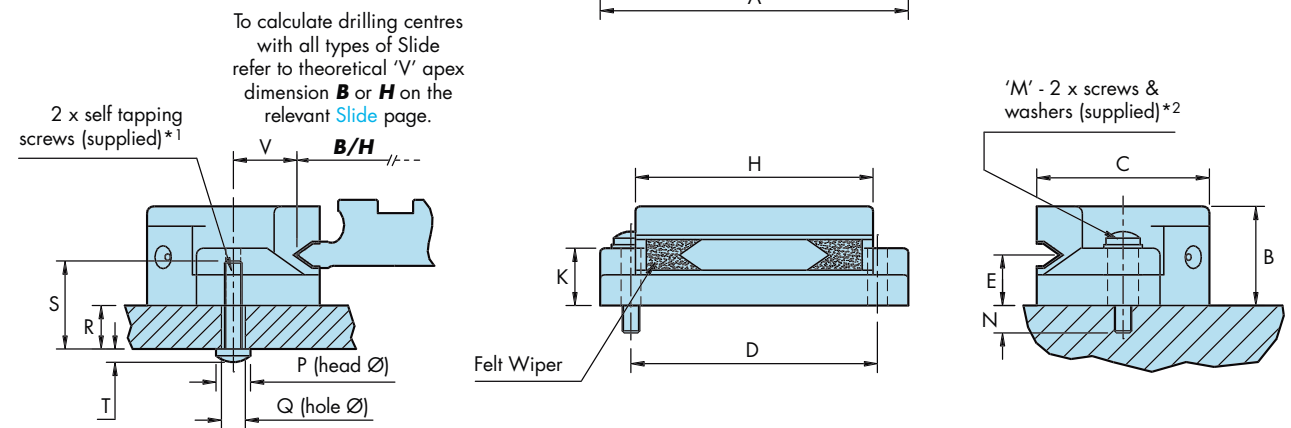
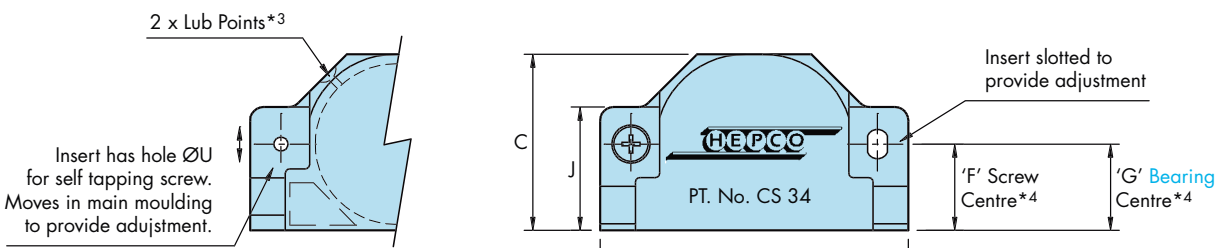

Part Number	Use With Bearings	A	B	C	D ±0.1	E	F	G	H	J	K	M*2		N	P	Q	R max	S	T	U	V	Mass ~g
												Screw	Length									
CS 18	...J 18...	42	13.8	21.2	32.5	6.75	12.3	10.4	32.3	18	6	M2.5	12	5.5	4.5	3	8.5	12	2	2	9.3	6
CS 25	...J 25...	55	18	30	44	9	14.8	14.8	43	22	8.6	M3	12	2.9	5.5	3.5	11	16	2	2.5	10.2	13
CS 34	...J 34...	70	22.5	40	56	11.5	19.6	19.6	54	28	13	M4	20	6.2	7	4.5	14	20	2.7	3.3	13.6	28
CS 54	...J 54...	98	36.5	60	80	19	29.7	29.7	78	40	20	M5	25	4	9	6	24	35	3.5	4	21	78

Part Number	Suitable for Slide Sections				
	MS	V	S	M	L
CS 18	X	✓	✓	✓	✓
CS 25	X	X	✓	✓	✓
CS 34	X	X	X	✓	✓
CS 54	X	X	X	X	✓

## Ordering Example

State quantity and part number ————— 4 x **CS 34**

### Notes:

- 2 self tapping screws for plastic are supplied with each Cap Seal. These have a cross-recessed pan head and use the PT thread form.
- 2 machine screws with cross-recessed pan heads (~DIN84A) and 2 flat washers (DIN125A) are supplied.
- Lubrication interval depends on length of stroke, duty and environmental factors. Replenish lubricant as necessary using a No.2 consistency lithium soap based grease. A male grease connector Part No. CSCHF4034 or a complete gun is available from Hepco if required.
- The fixing screw positions for the CS18 do not lie on the centreline of the nominal Bearing position, unlike all other sizes. Please ensure that this is taken into account if designing your own carriage plate.



# Cap Wipers

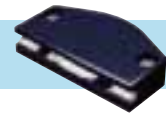

Rigid plastic Cap Wipers fit over individual Slimline Bearings, providing effective protection, plus wiping of debris from the Slide profile. Lubrication of the 'V' surface is provided by means of oil-impregnated felt wipers.

The internal cavity is filled with grease via the lubrication points, further improving lubrication and recharging the felt wipers as the grease partially liquefies under operation. Most systems require no further lubrication during the lifetime of the machine\*<sup>3</sup>. Fitment of Cap Wipers increases load, life and linear speed capability as well as improving operator safety.

Cap Wipers may be attached using either of the methods shown below. If using the through hole method, please ensure that the mounting hole is slotted to provide for adjustment.

**See Application Examples on pages 8 & 10**

Through Hole Fixing

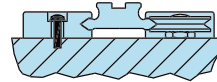
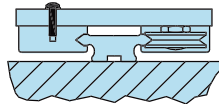

Tapped Hole Fixing

2 x Lub. Points\*<sup>3</sup>

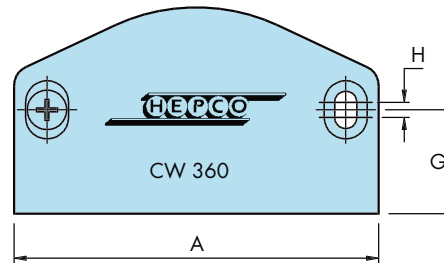
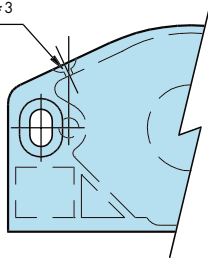

Screw Centre & Bearing Centre

2 Holes ØK to suit self tapping screws (not supplied)\*<sup>2</sup>

To calculate drilling centres with all types of Slide refer to theoretical 'V' apex dimension **B** or **H** on the relevant Slide page.

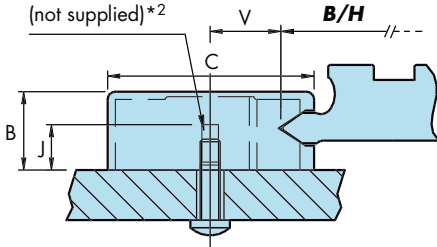

Felt Wiper

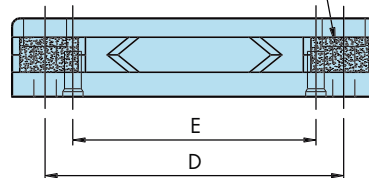

'M' - 2 x screws & washers (supplied)\*<sup>1</sup>

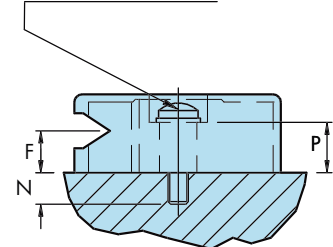

Part Number	Use With Bearings	A	B	C	±0.1 D	±0.1 E	F	G	H	J	K	M* <sup>1</sup>		N	P	V	Weight ~g
												Screw	Length				
CW 195	...J 195...	43	11.2	22.8	35	27.5	5.7	11.3	2	7	2.4	M2.5	12	3	8.5	7.4	6
CW 265	...J 265...	54	13	30.3	44	35	6.8	15.3	2.5	8.5	2.8	M3	16	5.5	10	10	10
CW 360	...J 360...	72	15.5	40.8	59	48	8.3	20.5	3	9	3.8	M4	16	5.5	10	13.8	20
CW 580	...J 580...	106	25	63.3	90	74	14.3	31.8	3.5	18	4.8	M5	25	4	20	23	55

Part Number	Suitable for Slide Sections				
	MS	V	S	M	L
CW 195	X	✓	X	X	X
CW 265	X	X	✓	X	X
CW 360	X	X	X	✓	X
CW 580	X	X	X	X	✓

## Ordering Example

State quantity and part number ————— 4 x **CW 360**

### Notes:

- 2 cross-recessed pan head screws to DIN 7985A and washers (DIN 433) are supplied with each Cap Wiper.
- Cap Wipers may be secured using the blind holes 'K' in the underside. These may be tapped thread form 'M' to take a machine screw\*, or will accept a self tapping screw.
- Lubrication interval depends on length of stroke, duty and environmental factors. Replenish lubricant as necessary using a No.2 consistency lithium soap based grease. A male grease connector Part No. CSCHF4034 or complete gun is available from Hpeco if required.

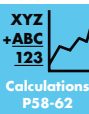

# Lubricators

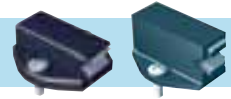

Plastic Lubricators normally fit one each side of the **Slide** between pairs of **Bearings**. However, any number may be fitted in any position according to requirements. Lubricators provide positive lubrication to the working surface of the Slide by means of spring loaded oil impregnated felt wipers which act as a reservoir.

System load capacity and life are greatly increased whilst retaining the low friction characteristics of dry running. Lubricators may be specified as part of any Hepco GV3 carriage assembly or used within the customers' own design.

One size of Lubricator will operate with a single size of **Bearing**, but can sometimes accommodate more than one size of **Slide** (see table). Lubricators are available to suit both Standard and Slimline Bearings (with slightly differing designs). Both types are supplied with suitable fasteners and can be attached with either a blind or through hole fixing.

**See Application Examples on pages 8, 11, 13 & 15**

## Lubricators for Standard Bearings

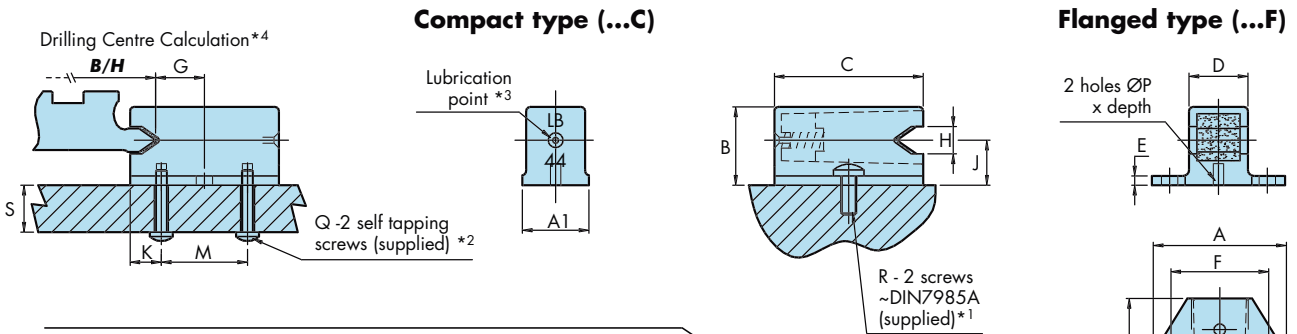

## Lubricators for Slimline Bearings

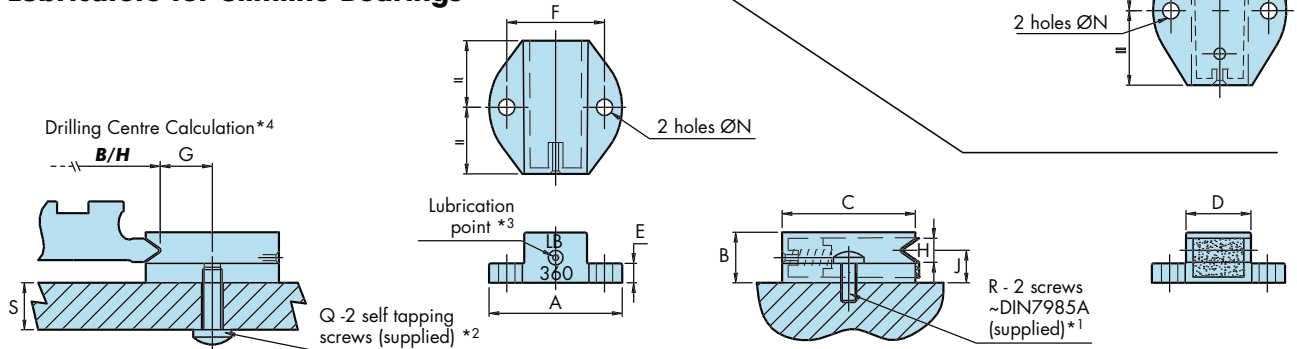

Part Number	A	A1	B	C	D	E	F	G	H	J	K	M	N	P	Thread x Length Q	Thread x Length R	S		Weight ~g
																	Max	Min	
LB 12	17	7	10	13	5.2	2	12	4.8	3.1	5.46	3	6.5	2.7	1.7 x 2.5	Ø2.5 x 5	M2.5 x 6	3	2.5	2
LB 20	19	8	12	22.5	6.5	2	13	7.3	7.2	6.75	4.75	13	2.7	1.7 x 2.5	Ø2.5 x 10	M2.5 x 6	8	7.5	3
LB 25	25	12	16.5	28	9.9	2	18	9	5.5	9	6	16	3.2	2.4 x 4.5	Ø3 x 10	M3 x 8	7.5	5.5	6
LB 44	34	17	20	38	15	2.4	25	11.8	7	11.5	8	22	4.2	2.4 x 5.5	Ø3 x 16	M4 x 10	13.5	11.5	16
LB 76	50	25	33.5	57	22.7	4.5	38	17.8	10	19	12	33	5.2	2.7 x 9	Ø3.5 x 22	M5 x 12	18.5	13	44
LB 195	19	-	8.7	19.8	6.85	5	13	7.5	4.1	5.7	-	-	2.7	-	Ø3 x 12	M2.5 x 10	9	-	2
LB 265	25	-	10.3	25	11.5	4	18	9.6	4.7	6.8	-	-	3.2	-	Ø3.5 x 12	M3 x 8	8.5	-	4
LB 360	34	-	12.9	34	16.6	5	25	13.4	6.2	8.3	-	-	4.2	-	Ø5 x 16	M4 x 10	11	-	8
LB 580	50	-	21.9	57	26.5	7.5	38	19.9	12.5	14.3	-	-	5.2	-	Ø6 x 25	M5 x 16	19	-	30

Part Number	Use With Bearings	Suitable for Slide Sections					Types Available	
		MS	V	S	M	L	Flanged (F)	Compact (C)
LB 12	...J 13...	✓	✓	✓	✓	✓	✓	✓
LB 20	...J 18...	X	✓	✓	✓	✓	✓	✓
LB 25	...J 25...	X	✓	✓	X	X	✓	✓
LB 44	...J 34...	X	X	X	✓	X	✓	✓
LB 76	...J 54...	X	X	X	✓	✓	✓	✓
LB 195	...J 195...	✓	✓	✓	✓	✓	✓	X
LB 265	...J 265...	X	✓	✓	✓	✓	✓	X
LB 360	...J 360...	X	X	✓	✓	✓	✓	X
LB 580	...J 580...	X	X	X	✓	✓	✓	X

## Ordering Details

Part Number **LB360 F**  
 Lubricator Type: **F**  
**F** = Flanged, **C** = Compact

### Notes:

- 2 machine screws with cross-recessed pan heads size R (DIN7985A ~ISO7045) are supplied with each flanged type and slimline lubricator.
- 2 self tapping screws for plastic (size Q) are supplied with each compact type Lubricator. These have a cross-recessed pan head and use the PT thread form.
- Lubrication interval depends on length of stroke, duty and environmental factors. Replenish lubricant as necessary using a 68 viscosity EP mineral oil.
- To calculate the drilling centres with **all** types of Slide, refer to theoretical 'V' apex dimension **B** or **H** on the relevant **Slide** page.

# Flange Clamps



XYZ  
+ABC  
123  
Calculations  
P 63

Flange Clamps enable the Slide System to act as a self-supporting constructional element of the machine. Manufactured from aluminium alloy, the clamps are anodised to achieve an attractive and corrosion resistant finish. They are available for use with all Double Edged **Spacer Slides** in the S series sizes and larger. Short Flange Clamps (type SFC) enable the Slide to be supported between two opposing faces. The Long Flange Clamp (type LFC) enables short lengths of Slide to be supported from one end only. The machined base mounting facility may be utilized by customers wishing to space the Slide System away from the mounting surface. Deflection of Slides can be determined using data given in the **Calculations** section.

## Assembly

During assembly, care should be taken to ensure that the Flange Clamps are positioned proud of the ends of the Slide\*<sup>1</sup>. Flange fixing screws should be located and slightly tightened, before clamping screws 'M' are fully tightened. Progressive tightening of each screw 'M' is recommended. Flange fixing screws may then be fully tightened.

Spacer  
Slides  
P 24-25

**See Application Examples on pages 10 & 14**

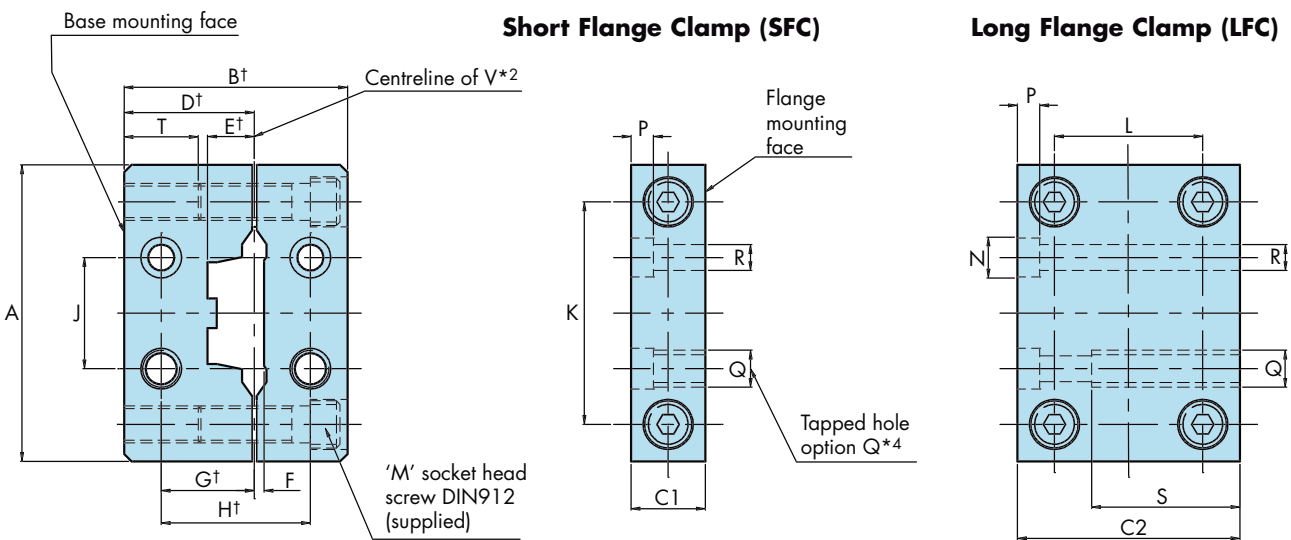

Dimensions marked† will differ slightly between application with P1 and P2 & P3 slides\*<sup>2</sup>

Part Number * <sup>3</sup>	For Use With Slide	A	B	C1	C2	D	E	F	G	H	J	K	L	M	N	P	Q	R	S	T	Weight /g	
																					SFC	LFC
S/L FC 25	NS25	60	55	15	55	30	10	1.8	20	35	20	45	35	M6 x 30	9.5	5	M8	6	35	17	120	405
S/L FC 35	NS35	76	62	20	60	37	10	1.8	25	40	26	56	40	M8 x 35	11	6	M10	7	30	17	240	740
S/L FC 50	NS50	86	62	20	60	37	10	1.8	26	42	32	66	40	M8 x 35	11	6	M10	7	30	17	260	770
S/L FC 44	NM44	80	60	20	60	35	12.5	2.5	25	40	30	60	40	M8 x 30	11	6	M10	7	40	20	220	630
S/L FC 60	NM60	100	62	25	75	37	12.5	2.5	27	42	40	78	50	M8 x 35	11	6	M10	7	40	17	370	1150
S/L FC M76	NM76	127	75	25	75	50	12.5	2.5	30	45	55	95	50	M10 x 40	14	8	M12	9	45	23	530	1780
S/L FC 76	NL76	120	75	25	75	45	19.5	4	30	50	55	95	50	M10 x 40	14	8	M12	9	45	23	500	1430
S/L FC 120	NL120	170	100	25	75	62.5	19.5	4	35	54	95	140	45	M12 x 50	17	11	M16	11	40	35	1050	2750

## Ordering Details

**S FC60 (Q)**

Clamp Length  
 'S' = Short Type (use one at each end of slide)  
 'L' = Long type (use for cantilever slide mounting)

**Q** indicates tapped hole option is required  
 Leave blank for through hole fixing.  
 Part Number (60 = nominal Slide width in mm\*<sup>3</sup>)

### Notes:

- For mounting Slides between opposing faces, Slides should be ordered 2 mm shorter than the required span.
- The drawings show dimensions from the centreline of Slide 'V' when in the clamped condition. The figures quoted are valid for precision grades P2 & P3. For P1 Slides, dimensions D & E will be reduced by 0.2mm and dimensions B & H will be reduced by 0.4 mm. The keyway register ensures the Slide is located centrally.
- Flange Clamps are available to suit both the NM76 and NL76 Slides. For the NM76 compatible flange clamp, please state S/L FC M76 as per table.
- Standard drilled flange clamps will be reworked for customers requiring tapped hole option 'Q'.



# Flat Tracks

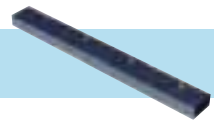

Hepco GV3 Flat Tracks are made from high quality carbon steel and are hardened on all four faces to provide an extremely durable running surface. They have been designed to be used with the Hepco range of [Track Rollers](#). Flat Tracks are often used in conjunction with Hepco V [Slides](#) in large systems where the design can eliminate the requirement to set slides accurately parallel. Flat Tracks are available in 4 sizes and in a number of quality grades. The P3 grade has a commercial finish on all faces and is sufficiently accurate for many applications whilst the other grades are precision surface ground to high accuracy on various faces according to the requirements of the application.

The standard means of securing Flat Tracks to the mounting surface is via counterbored fixing holes in the positions shown. Other fixing hole possibilities are available on request. Tracks in their free unmounted state are not necessarily absolutely straight, however, they may be set to the required degree of straightness during installation. It is recommended that holes in the mounting surface are positioned by 'spotting through' from the flat track.

**See Application Examples on page 16**

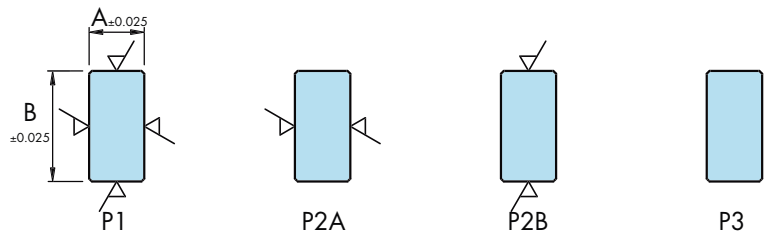
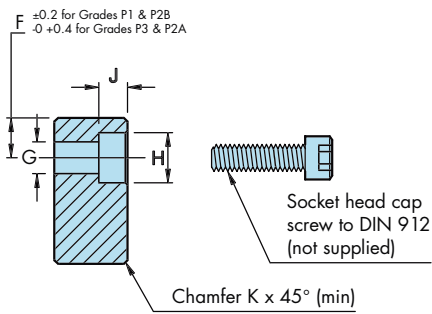
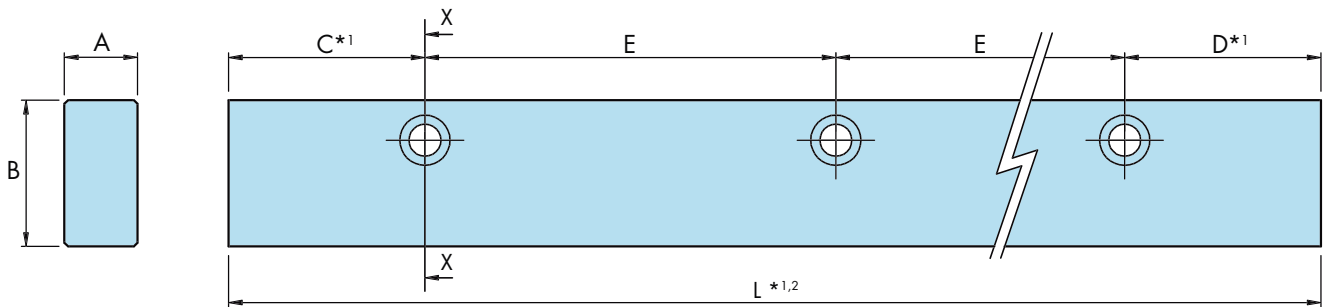
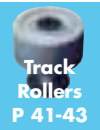

∇ Indicates surfaces which are precision ground

Part Number	Use With Track Roller	A		B		C*1	D*1	E	F	G Ø	Screw Size	H Ø	J ~	K (min)	L*1,2 (max)	Weight kg/m
		P1 & P2A	P2B & P3	P1 & P2B	P2A & P3											
FT 24 12	...R 18...	12	12.4	24	24.4	20.5	20.5	45	7.5	6	M5	10	5	0.4	2000	2.3
FT 32 16	...R 25...	16	16.4	32	32.4	43	43	90	8.75	7	M6	11	6	0.4	4020	4
FT 40 20	...R 34...	20	20.4	40	40.4	43	43	90	12	9	M8	15	8	0.4	4020	6.3
FT 66 33	...R 54...	33	33.4	66	66.4	88	88	180	17	14	M12	20	12	0.4	4020	17

## Ordering Details

**FT4020 L1830 P2A C15 D15**

Part Number FT4020  
 Track Length 'L' = 1830 mm  
 Precision grade: options are P1, P2A, P2B & P3  
 Bespoke values of 'C' & 'D' dimensions  
 Leave blank if standard (see table)

### Notes:

- Any length of Flat Track within max length stated can be supplied, but for optimum price and delivery time, track lengths should be specified which maintain the C and D dimensions in the table above. In all cases unless otherwise specified by the customer, C and D dimensions will be supplied equal.
- Where tracks longer than maximum length are required, two or more lengths in grades P1, P2A & P2B can be matched suitable for butting, on request. In these cases the mating ends will be ground square.

# Narrow Track Rollers



The Hepco range of Narrow Track Rollers complements the other ranges of Bearings in the GV3 programme. They are available mounted on both Concentric and Eccentric Through Hole Fixing studs, but there is no Blind Hole version.

Narrow Track Rollers can be used in conjunction with Hepco [Flat Tracks](#), [Single Edge Spacer Slides](#) and almost any type of running surface. Each uses a high capacity single row deep groove ball bearing with a substantial and stiff outer ring and a crowned outer profile. Their design makes them particularly suited to use as a retaining roller on the rear face of Single Edged Spacer Slides, and their low cost makes them suitable for any application where the high load capacity of the [Wide Track Rollers](#) is not needed.

All Track Rollers are available with the **Nitrile Seal** option which provides a higher degree of sealing against ingress of water and debris than does the default metal shielded type. A small increase in friction may result.

**See Application Examples on page 16**

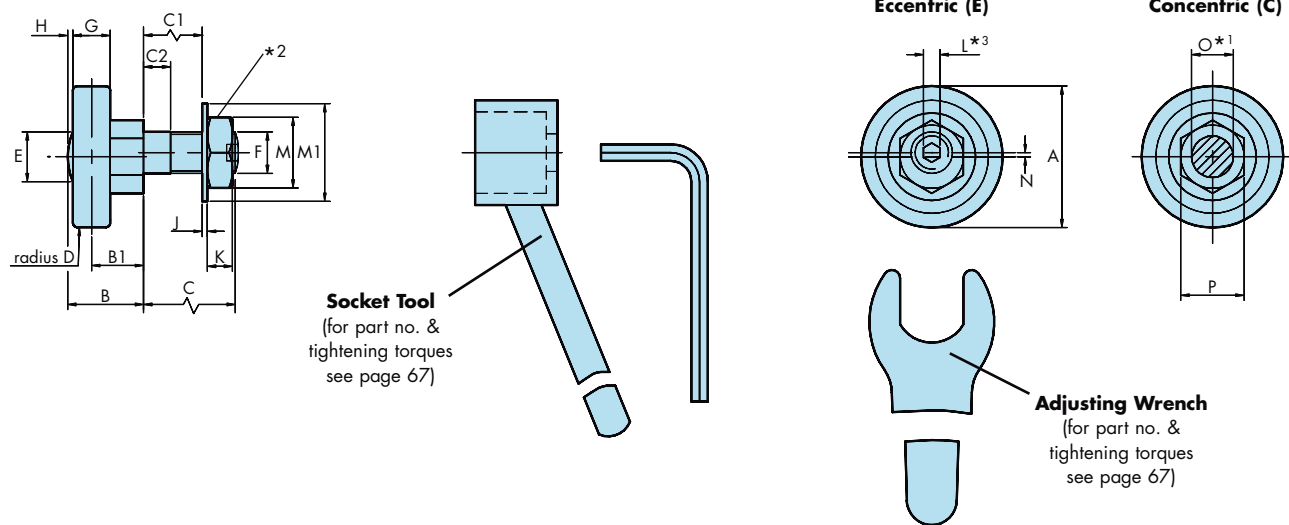

**Socket Tool**  
(for part no. & tightening torques see page 67)

**Adjusting Wrench**  
(for part no. & tightening torques see page 67)

Part Number	Use With Flat Track *5	A	B	B1	C	C1	C2	D	E	F Metric Fine	G	H	J	K
LRN 18 ...	FT 24 12	18	11.5	8	14	10	2.5	500	7	M6 x 0.75	5	1	0.8	3.2
LRN 25 ...	FT 32 16	25	14.5	10	19	13	5	500	10	M8 x 1	7	1	1	5
LRN 34 ...	FT 40 20	34	18.2	12.5	22	14.8	6	500	12	M10 x 1.25	9	1.2	1.25	6
LRN 54 ...	FT 66 33	54	29.5	21	30	20.4	8	500	23.5	M14 x 1.5	14	1.4	1.6	8

L*3	M	M1	N	+0 -0.03 O*1	P	Weight ~g	Max Working Load Capacity	Roller Static and Dynamic Radial Load Capacities (N)*4	
								Co	C
2.5	10	13	0.7	6	11	16	400	593	1438
3	13	17	0.75	8	13	40	1000	1333	3227
4	17	21	1	10	15	85	2000	2600	5921
6	22	28	1.5	14	27	310	5000	6657	13595

Part Number	Options Available	
	Metal Shields (+)	Nitrile Seals (NS)
LRN 18 ...	X	✓
LRN 25 ...	✓	✓
LRN 34 ...	✓	✓
LRN 54 ...	✓	✓

## Ordering Details

**LRN25 C (NS)**

Part Number

**LRN** Indicates a Narrow Track Roller  
25 denotes roller diameter in mm

**Nitrile Sealed Bearings**

Leave blank if metal shields are required

**C** = Concentric (fixed) or **E** = Eccentric (adjustable)

### Notes:

- It is recommended that holes to suit Track Roller mounting studs should be reamed to tolerance F6 for a sliding fit.
- Nuts are chemically blacked on the concentric version and bright zinc plated on the eccentrics for identification purposes.
- All eccentric Narrow Track Roller fixing studs are supplied with sockets for adjustment as shown.
- The quoted static and dynamic load capacities are based on industry standard calculations. These do not accurately reflect system performance, and are only provided for comparison with other systems. Please use the Max Working Load figures and the load/life [calculations](#) on page 60 to determine system performance.
- Each size of Narrow Track Roller has been designed for use with a specific size of [Flat Track](#), as shown in the table. However, any Track Roller may be used in conjunction with any size of Flat Track, Single Edged Slide or other running surface according to practicality of design.

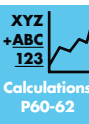
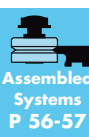

# Wide Track Rollers



The Hepco Range of Wide Track Rollers includes a broad range of mounting options to cater for most design requirements, and can be used in conjunction with Hepco [Flat Tracks](#), [Single Edge Spacer Slides](#) and almost any type of running surface. Each uses a high capacity twin row deep groove ball bearing with a substantial and stiff outer ring and a crowned outer profile.

The **Through Hole Fixing type** is available in two stud lengths covering most thicknesses of mounting plate and are available with Concentric (fixed) and Eccentric (adjustable) fixing studs.

The **Blind Hole Fixing type** allows mounting into a solid machine base where through mounting holes are not possible, or where the thickness of the mounting plate is too great. The Blind Hole Fixing type is also useful where adjustment from the front is preferred, or where access to the opposite side of the mounting hole is restricted. They are available in Concentric type (C) which are fixed, or Eccentric type (E) which are adjustable.

The Wide Track Rollers are available in the same basic sizes as Hepco Standard 'V' [Bearings](#). This ensures that systems using both 'V' Bearings and Track Rollers will be matched well in terms of functionality and performance.

## Through Fixing Type (SR/LR)

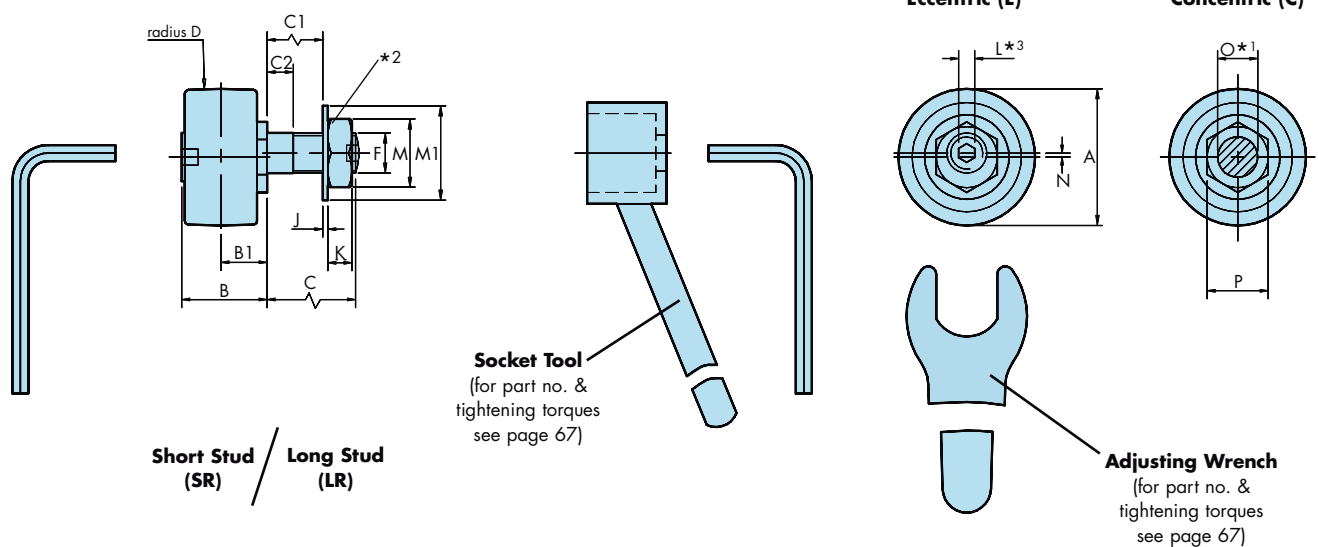

Part Number	Use With Flat Track*6	A	B	B1	C		C1		C2		D	E
					Short Stud	Long Stud	Short Stud	Long Stud	Short Stud	Long Stud		
... R 18 ...	FT 24 12...	18	12.4	6.75	7.4	14	3.4	10	2.4	2.5	500	7
... R 25 ...	FT 32 16...	25	16.6	9	9.8	19	3.8	13	3.4	4.9	500	10
... R 34 ...	FT 40 20...	34	21.3	11.5	13.8	22	6.6	14.8	5.2	5.9	500	12
... R 54 ...	FT 66 33...	54	34.7	19	17.8	30	8.2	20.4	5.7	7.9	500	23.5

S	S1	T	T1	T2	U	U1	V	W1	W2	X	Y	Z
8	10.5	10	4	8	38	54	11	12.3	7.8	M4	7	7
7	9	12	5	10	50	72	14	16	11	M5	8.5	10
9.5	8.5	17.5	6.5	12.5	60	90.5	17	21	15.3	M6	10	14
14.5	16.4	23.5	10.5	18.5	89.5	133	25	31	25	M8	13	20

### Notes:

1. It is recommended that holes to suit Track Roller mounting studs should be reamed to tolerance F6 for a sliding fit.
2. Nuts are chemically blacked on the concentric version and bright zinc plated on the eccentrics for identification purposes.
3. All eccentric Wide Track Roller fixing studs are supplied with sockets for adjustment as shown.
4. 'R' dimension is both the eccentric offset of the adjusting nut and the total adjustment available at the roller centre line for 360° rotation of the adjusting nut.
5. The quoted static and dynamic load capacities are based on industry standard calculations. These do not accurately reflect system performance, and are only provided for comparison with other systems. Please use the Max Working Load figures and the load/life [calculations](#) on page 60 to determine system performance.
6. Each size of Wide Track Roller has been designed for use with a specific size of [Flat Track](#), as shown in the table. However, any Track Roller may be used in conjunction with any size of Flat Track, Single Edged Spacer Slide or other running surface according to practicality of design.

# Wide Track Rollers



Common mounting faces for Track Rollers and 'V' Bearings in conjunction with Flat Tracks and Single Edge Spacer Slides have been achieved in most instances, to simplify customer's machine design.

All Track Rollers are available with the **Nitrile Seal** option which provides a higher degree of sealing against ingress of water and debris than does the default metal shielded type. A small increase in friction may result.

Since Track Rollers have a pure rolling contact with the track, wear is much less of an issue than it is with 'V' Bearings. Special lubricating devices are not normally required, but it is recommended that Rollers and Tracks are lightly oiled to ensure maximum durability.

See Application Examples on page 16

## Blind Hole Fixing Type (BHR)

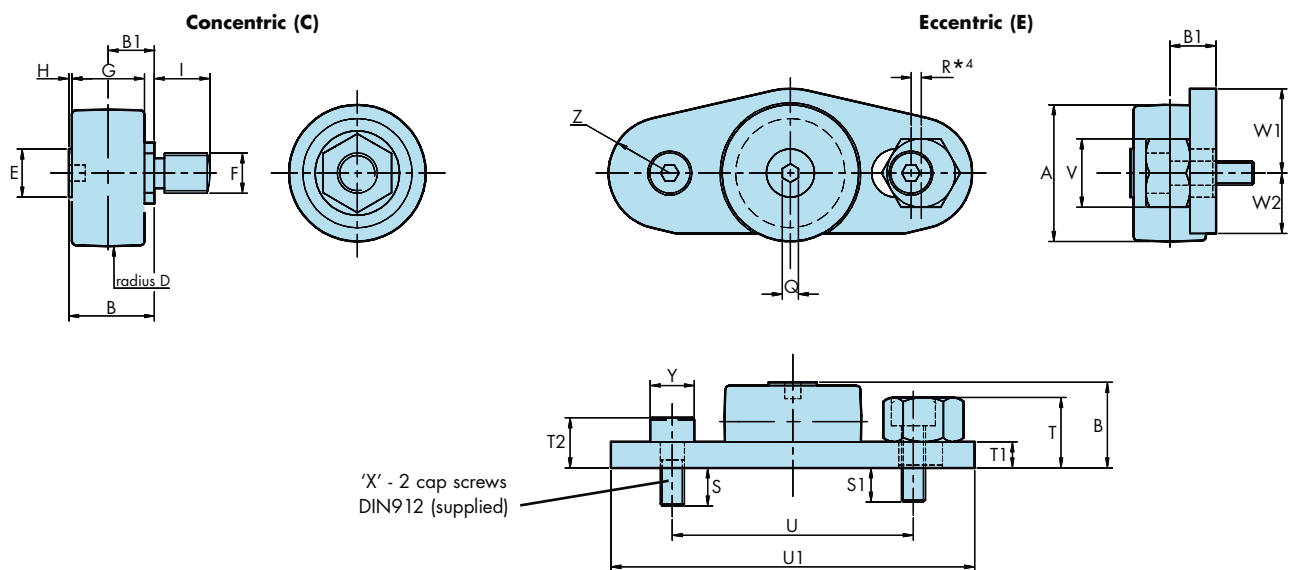

	F	G	H	I	J	K	L*3	M	M1	N	<sup>+0</sup> <sub>-0.03</sub> O*1	P	Q	R*4
	Metric Fine													
	M6 x 0.75	10	0.6	7.4	0.8	3.2	2.5	10	13	0.7	6	11	2	1.2
	M8 x 1	14	0.5	9.8	1	5	3	13	17	0.75	8	13	3	1.5
	M10 x 1.25	18	0.7	13.8	1.25	6	4	17	21	1	10	15	4	2.0
	M14 x 1.5	28	1.6	17.8	1.6	8	6	22	28	1.5	14	27	8	3.0

SR...	Weight ~g			Max Working Load Capacity	Static and Dynamic Radial Load Capacities (N)*5	
	LR...	BHR...C	BHR...E		C <sub>0</sub>	C
20	21	19	45	600	1168	2301
50	55	45	105	1600	2646	5214
120	125	110	235	3200	5162	9560
440	450	415	800	8000	13271	21989

Part Number	Options Available	
	Metal Shields (-)	Nitrile Seals (NS)
... R 18 ...	X	✓
... R 25 ...	✓	✓
... R 34 ...	✓	✓
...R 54 ...	✓	✓

## Ordering Details

Fixing type. Choose from:

**SR** = Short Stud, **LR** = Long Stud

& **BHR** = Blind Hole Fixing

Part Number (~ Roller Diameter in mm)

**LR 25 C (NS)**

**Nitrile Sealed** Rollers

Leave blank if metal shields are required

**C** = Concentric (fixed) or **E** = Eccentric (adjustable)

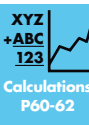
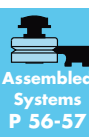



# Racks

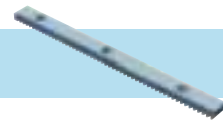

Hepco GV3 Racks provide a durable and powerful linear drive when used in conjunction with Hepco or other good quality hardened tooth **Pinions**.

Racks are made from high quality carbon steel, ground on all faces prior to tooth cutting. They are available in 4 standard sizes, with tooth forms from 0.7 to 2.0 metric module with 20° pressure angle and are supplied in an attractive corrosion resistant black finish.

The teeth are machined to a high degree of precision and conform to ISO 1328 grade 8. The back face of the Rack is controlled parallel to the tooth pitch line enabling it to be used as a register for setting.

The Racks are available with counterbored fixing holes, through tapped holes or without holes for customers to drill as required. All holes are accurately positioned to enable customers to pre-drill their mounting holes.

Care should be taken at installation to set the Rack straight, and to align parallel with the relevant **Slide**\*4. Adjustment for the **Pinion** should be provided in order to achieve the desired mesh quality. For best performance, the teeth should be lubricated with No.2 consistency lithium soap-based grease.



**See Application Examples on pages 12 & 13**

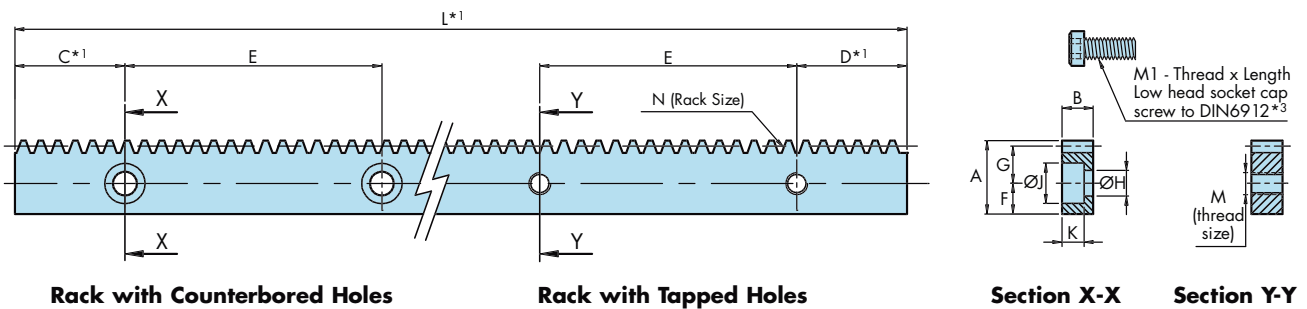

Part Number	Use With Pinions	A	B	C	D	E ±0.25	F	G	H	J	K	L*1,2 (max)	M	M1*3		N mod	Max Rack Force (N)*3	Weight kg/m
														Screw	Part No.			
R 07 ...	P 07 W 5 ...	12.7	4.0	20.5	20.5	45	6.35	5.65	4.5	7.6	2.9	1828	M4	M4 x 10	FS410	0.7	110	0.37
R 10 ...	P 10 W 7 ...	15.65	6.75	43	43	90	7.8	6.85	5.5	9.6	4.0	1828	M5	M5 x 10	FS510	1.0	250	0.77
R 15 ...	P 15 W 8 ...	20.0	8.25	43	43	90	8.3	10.2	6.5	11	4.5	1828	M6	M6 x 12	FS612	1.5	400	1.2
R 20 ...	P 20 W 13...	31.75	14.0	43	43	90	13.2	16.55	11	18	10.5	1828	M10	M10	-	2.0	950	3.3

## Ordering Details

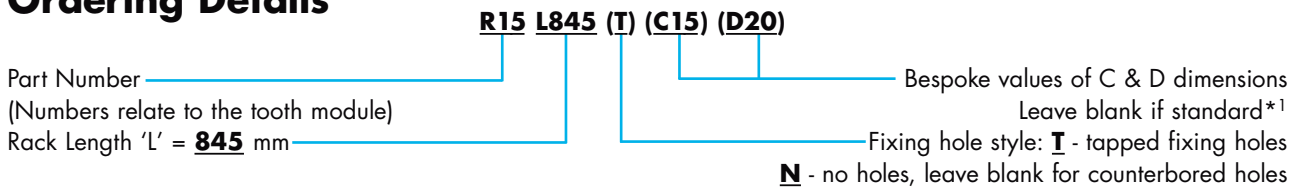

### Notes:

- Any length of rack within L max dimension can be supplied, but for optimum price and delivery time, lengths should be specified which maintain the C and D dimensions in the table above. In all cases unless otherwise specified by the customer, C and D dimensions will be supplied equal.
- Where longer racks are required, standard lengths matched suitable for mounting end-to-end will be supplied. In these cases additional holes may be inserted to give support near the join positions. When mounting such compound racks, care must be taken to match accurately the pitch line and tooth spacing across the join. A rack matching tool, which is a short length of rack to engage in the two pieces to be mounted, will be supplied with such orders.
- The standard counterbored holes on the three smallest sizes suit low head hex socket cap screws (to DIN 6912). These screws are not universally stocked so Hepco offers them as a convenience to customers in a single length for each thread size (see table). The largest size R20 racks are thick enough to accommodate cap head screws to DIN912 which are widely available.
- Racks in their free unmounted state are not necessarily absolutely straight. If straightness is important, the rack should be set by bolting down with the rear face located against a register.
- The Max Rack Force quoted is that continuous drive force which can be sustained by a well lubricated rack used in conjunction with the appropriate Hepco **Pinion**.



# Pinions



Hepco supplies a range of pinions which are compatible with **Rack Cut Single Edge Spacer Slides**, **Double Edge Spacer Slides with fitted racks** and **Separate Racks**. Pinions have teeth with a 20° pressure angle and metric module tooth sizes. They are made to standard ISO 1328 grade 10 and are nitride hardened for durability.

Pinions are available in 2 formats: **Boss type** and **Shaft type**. The Boss type is supplied with a precision bore, optional keyway\*1 and grub screw and is specified for general use. The Shaft type includes an extended shaft with keyed diameter, which is compatible with the hollow shaft of the Hepco worm **Gearbox/AC Geared Motor and Flange**. This assembly provides a powerful and accurate linear drive system. (See **Rack Driven Carriage** page for a complete system using these parts.)

Shaft type pinions are supplied with the key, retaining washer and screw necessary to connect to the worm gearbox. For best performance, the teeth of the rack and pinion should be lubricated with No.2 lithium soap-based grease.

**See Application Examples on pages 11, 12, 13 & 14**

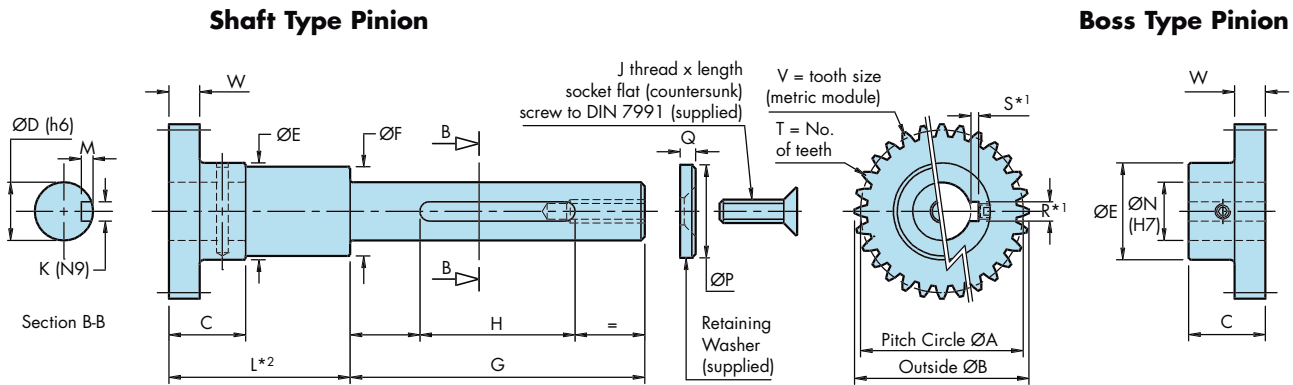

Shaft Type pinions are supplied with a steel key.

Part Number	A	B	C	D	E	F	G	H	J Thread x Length	K	L*2	M	N	P	Q	R	S	T	mod V	W	Weight/g Boss Type
P05 W7 T28...	14	15	14	-	10	-	-	-	-	-	-	-	5	-	-	-	-	28	0.5	7	11
P07 W9 T28...	19.6	21	17	-	16	-	-	-	-	-	-	-	5	-	-	-	-	28	0.7	9	31
P07 W5 T28...	19.6	21	13	-	16	-	-	-	-	-	-	-	5	-	-	-	-	28	0.7	5	22
P10 W11 T42...	42	44	23	15	30	23	76	40	M6 x 16	5	to order	3	15	24	4	5	2.3	42	1	11	160
P10 W7 T42...	42	44	18.5	-	30	-	-	-	-	-	-	-	15	-	-	5	2.3	42	1	7	120
P125 W14 T34...	42.5	45	25.5	20	30	30	81	50	M8 x 20	6	to order	3.5	15	32	5	5	2.3	34	1.25	14	200
P15 W8 T28...	42	45	19.8	15	30	23	76	40	M6 x 16	5	57.4	3	15	24	4	5	2.3	28	1.5	8	125
P20 W20 T27...	54	58	35	20	40	30	81	50	M8 x 20	6	to order	3.5	20	32	5	6	2.8	27	2	20	430
P20 W13 T27...	54	58	25	20	40	30	81	50	M8 x 20	6	64.4	3.5	20	32	5	6	2.8	27	2	13	300

Part Number	For Use With				Available Types	
	Rack	Single Edge Spacer Slide	Double Edge Spacer Slide	Worm Gearbox/AC Geared Motor	Boss	Shaft
P05 W7 T28...	-	NMSE...R	-	-	✓	✗
P07 W9 T28...	-	NVE...R	-	-	✓	✗
P07 W5 T28...	R07...	-	NV...R	-	✓	✗
P10 W11 T42...	-	NSE...R	-	WG3...	✓	✓
P10 W7 T42...	R10...	-	NS...R	-	✓	✗
P125 W14 T34...	-	NME...R	-	WG4...	✓	✓
P15 W8 T28...	R15...	-	NM...R	WG3...	✓	✓
P20 W20 T27...	-	NLE...R	-	WG4...	✓	✓
P20 W13 T27...	R20...	-	NL...R	WG4...	✓	✓

## Ordering Details

### P20 W13 T27 S (68) (D20)

Part Number  
number is 10 x tooth module (size)  
~ Face width 'W' = **13** mm  
Number of teeth 'T' = **27**

Shaft engagement diameter D = **20** mm  
Leave blank for Boss type Pinion  
Pinion shaft length (Dim 'L' above) in mm  
Leave blank for Boss type Pinion  
Pinion format: B = Boss type;  
BK = Boss type with key; S = Shaft type

### Notes:

- Small boss type pinions (with bores below 8 mm) are not supplied with keyways as standard. It is usual to secure these small pinions by an alternative method such as a set screw onto a flat on the mating shaft or using a taper pin.
- The length of the pinion shaft will depend on the exact design. Shaft pinions are made to length from part machined stock, to ensure rapid delivery and economy. The lengths shown for the P15W8T28 & P20W13T27 are those used in the Hepco Rack Driven Carriage. Other lengths are available as required.

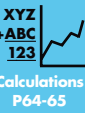

# Belt Driven Carriages

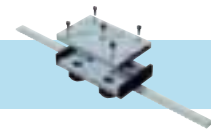

Hepco Belt Driven Carriages are available to suit 10 sizes of Double Edge Slide in all grades of precision. They have all of the benefits of the Standard Carriages along with many additional features:

Carriages may be specified with the **Removable Option** which is the key feature of the Removable Carriage. This allows the carriage to be disengaged from the Slide at any position along its length, without the need for complete disassembly.

Each Belt Driven Carriage incorporates a base plate and a **Removable Top Plate** which can simply be unscrewed and reworked as required. Tapped holes are provided in convenient positions to enable components to be attached.

Belt Driven Carriages are normally supplied as **Assembled Units (AU type)** which are factory assembled and set to the Slide. Information regarding the options for Bearings, lubrication devices and load capacities is given on the page for Standard Carriages\*<sup>1</sup>.

The Belt Driven Carriage incorporates an integral **Belt Gripper & Tensioner** at each end. The Gripper securely holds the toothed belt and the fixing screws allow controlled pretensioning and adjustment.

## Example: Short Carriage with Cap Seals on a Spacer Slide

### Optional Toothed Belt

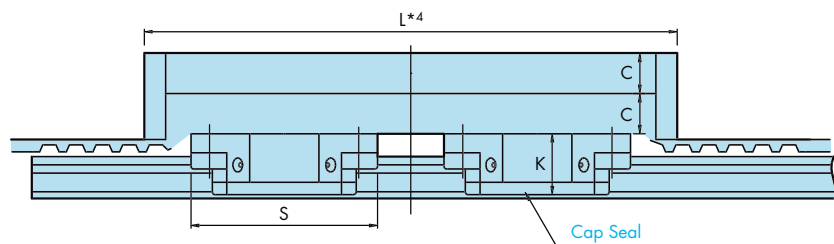
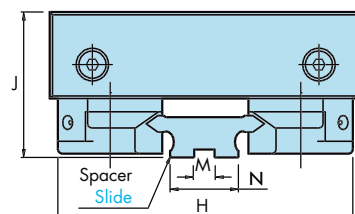
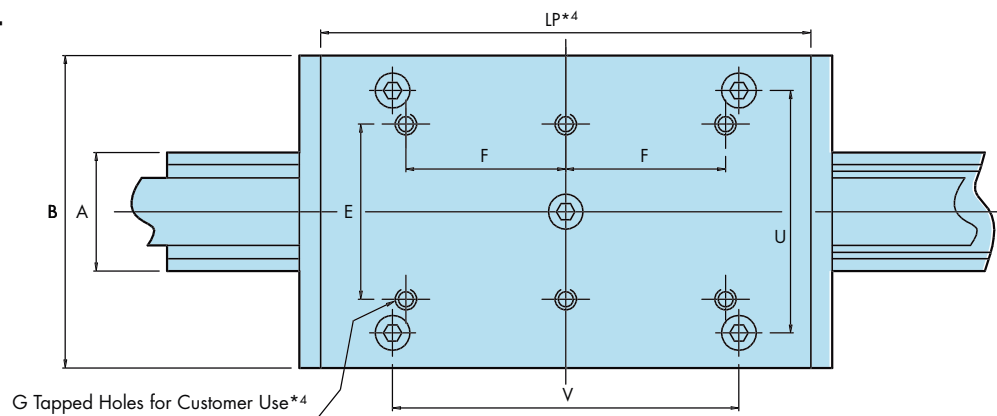
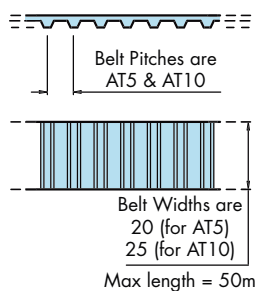

Part Number	For Use With Slides	Bearing Ø	A	B	C	D *4	E	F *4	G *4		H	J *2			
									No of Holes x Thread			P1	P2 & P3		
AU BD 35 25...	S 35 & NS 35	25	35	90	13	70	150	48	50	100	4 x M6	6 x M6	88	45	45.2
AU BD 50 25...	S 50 & NS 50	25	50	112	14	82	162	60	50	90	4 x M6	6 x M6	103	47	47.2
AU BD 44 34...	M 44 & NM 44	34	44	116	15	95	168	65	60	90	6 x M8	6 x M8	114	54	54.2
AU BD 60 34...	M 60 & NM 60	34	60	135	17	119	199	75	75	115	6 x M8	6 x M8	130	58	58.2
AU BD 76 34...	M 76 & NM 76	34	76	150	18	139	239	100	80	130	6 x M8	6 x M8	146	60	60.2

Carriage Part Number	Part Number	Pulleys							Belt Part No.	Belt Tension *5	
		W	W1	X	X1	Y	Z	No of Teeth		Working	Max
AU BD 35 25...	TP20... & IP20...	49.5	47	25	27	12	39.4	27	DB 20 AT5...	560	5390
AU BD 50 25...	TP20... & IP20...	49.5	47	25	27	12	39.4	27	DB 20 AT5...	560	5390
AU BD 44 34...	TP25... & IP25...	67	67	30	32	15	56.8	20	DB 25 AT10...	1225	12450
AU BD 60 34...	TP25... & IP25...	67	67	30	32	15	56.8	20	DB 25 AT10...	1225	12450
AU BD 76 34...	TP25... & IP25...	67	67	30	32	15	56.8	20	DB 25 AT10...	1225	12450

### \* Notes:

- For load capacities see Standard Carriages page. It is strongly recommended that load and life are determined using the methods shown in the Calculations section.
- Some dimensions will vary by the amount of the grinding allowance according to the grade of slide selected. All Carriages are compatible with all grades of Slide.
- CH (Controlled Height) Bearings are selected to be within  $\pm 0.005$  mm in respect of 'B1' dimension on pages 32-33 compared to Standard Bearings which are within  $\pm 0.025$  mm. Customers requiring CH Bearings with the same tolerance band in respect of a number of Carriages should state this on their order.
- Carriages are available in 2 standard lengths, therefore bearing centres 'D' and the number and position of component mounting holes 'G' will vary accordingly. Hepco will make carriages to your special length requirements on request.
- The Max belt tension stated relates to the breaking load, and is provided for comparison purposes only. The working belt tension should not be exceeded when used with Hepco pulleys and grippers.
- The removable option is not available in conjunction with Cap Seals or controlled height bearings.
- The IP 25 P15 idler pulley is fitted with 2 off 6302 2RS deep groove ball bearings (C = 11400N, Co = 5400N per bearing). The IP 20 P12 idler pulley is fitted with 2 off 6001 2RS deep groove ball bearings (C = 5070N, Co = 2360N).

# Belt Driven Carriages

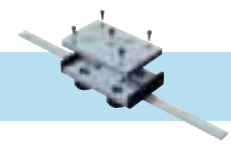

In addition to the Carriage, Hepco will supply the necessary belt and pulleys to complete the system. Belts are steel reinforced polyurethane, and have the high strength AT tooth profile. Bored drive pulleys with zero backlash AT profile teeth are available in one size to provide a useful driving ratio for most applications. Idler pulleys are plain without teeth and are supplied complete with fitted deep groove ball bearings, ready to fit onto a shaft.

Customers wishing to run the Carriage on a Flat Slide must specify the counterbored slide fixing hole option as the belt would otherwise foul the heads of the screws.

Customers requiring a beam mounted Belt Driven Carriage with pulleys should consider the **Hepco DLS Linear Transmission** which is a complete ready to mount positioning system including drive motor if required. Please send for the **DLS** catalogue.

**See Application Examples on pages 11, 12 & 14**

## Example: Short Carriage with Lubricators on a Flat Slide

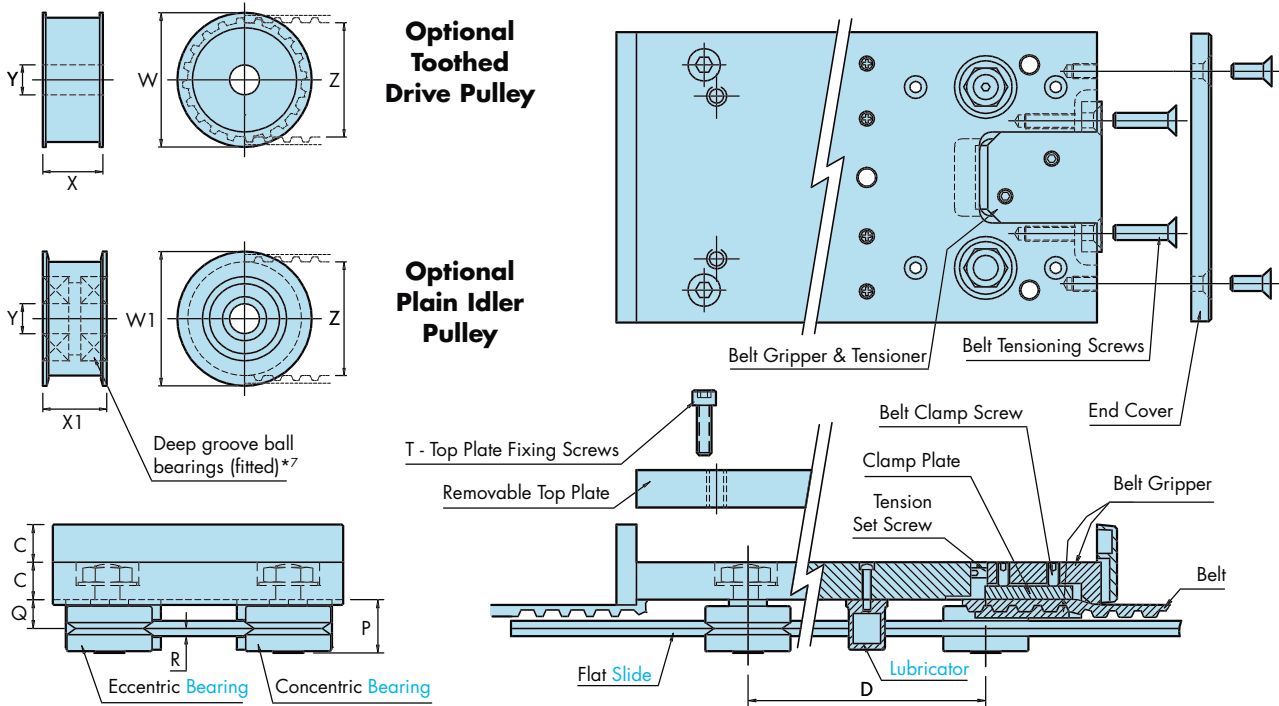

	K	L *4		LP *4		M	N *2			P	Q	R *2		S	T *4		U	V *4		Carriage ~Weight (kg) *4	
							P1 & P2	P3	P1			P2 & P3									
	18	150	230	138	218	8 x 3	25	25.4	16.6	9	2.4	2.5	55	4 x M6	5 x M6	70	97	180	1.2	1.7	
	18	160	240	148	228	10 x 3.5	40	40.4	16.6	9	2.4	2.5	55	5 x M6	5 x M6	88	112	192	1.6	2.3	
	22.5	200	280	184	264	8 x 3	26	26.4	21.3	11.5	3.1	3.2	70	5 x M8	5 x M8	90	130	215	2.0	2.8	
	22.5	224	304	208	288	10 x 3.5	42	42.4	21.3	11.5	3.1	3.2	70	5 x M8	5 x M8	109	156	236	3.4	4.3	
	22.5	244	344	228	328	12 x 4	58	58.4	21.3	11.5	3.1	3.2	70	5 x M8	5 x M8	124	188	288	4.1	5.6	

## Ordering Details

**AUBD4434 L200 (R) (CS) (DR) (NS) (CH) (T) + Slide Part Number**

Part Number

**AU...** = Assembled Carriage

Carriage Length 'L' = 200 mm

**R** = Removable Carriage Option

Leave blank if not required\*6

Lubrication Options -

**CS** = Cap Seals or **LB** for Lubricators

Leave blank if not required

**T** = Tamper Proof option

Leave blank if not required

**CH** = Controlled Height Bearings\*3

Leave blank if not required

**NS** = Nitrile Sealed Bearings

Leave blank if not required

**DR** = Double Row Bearings

Leave blank if not required

## Ordering Details for Pulleys & Belts

**TP 20 AT5 T27 P12 0** ————— **Toothed Drive Pulley** for 20 mm wide AT5 belt with 27 teeth & 12 mm plain bore.

**TP 25 AT10 T20 P15 0** ————— **Toothed Drive Pulley** for 25 mm wide AT10 belt with 20 teeth & 15 mm plain bore.

**IP 20 P12** ————— **Idler Pulley** for 20 mm wide belt with fitted bearings to run on 12 mm Ø shaft.

**IP 25 P15** ————— **Idler Pulley** for 25 mm wide belt with fitted bearings to run on 15 mm Ø shaft.

**DB 20 AT5 L2345** ————— **Drive Belt** 20 mm wide with AT5 tooth profile. **L2345** is the required length in mm.

**DB 25 AT10 L3456** ————— **Drive Belt** 25 mm wide with AT10 tooth profile. **L3456** is the required length in mm.



# Rack Driven Carriages



Hepco Rack Driven Carriages are available to suit 5 sizes of Double Edge Spacer [Slide](#) (with fitted racks) in all grades of precision. They have all of the benefits of the Standard type [Carriage](#) along with many additional features including micro-adjustment facility for achieving the correct engagement of the [Pinion](#) with the rack.

Rack Driven Carriages include the Hepco Worm [Gearbox](#), Drive [Flange](#) and Shaft [Pinion](#) of suitable ratio. The Gearbox may be supplied coupled with an intergral Hepco AC Motor which is the most economical means of producing point-to-point linear motion, and which may be controlled for speed and acceleration via the [AC Speed Controller](#), which is available from Hepco. The Gearbox can also be supplied with an adaptor flange and input shaft coupling tailored to suit other makes or types of motors including steppers and servos which benefit from the low backlash of the Hepco Gearbox.

Bespoke carriages are available on short delivery for customers wishing to use their own motor, gearbox and pinion.

Part Number	Use with Slides	A ~	B	F	F1*4		G	G1	G2	H	J	K	N	P	P1
					Standard	Removable									
AU RD 44 34...	NM 44...R	44	133	38.2	72.3	74.8	28.8	22	97.8	56	74.1	43	18	22.5	70
AU RD 60 34...	NM 60...R	60	144	29.7	88.3	90.8	20.3	22	105.3	56	74.1	43	18	22.5	70
AU RD 76 34...	NM76...R	76	154	21.7	104.3	106.8	12.3	22	113.3	56	74.1	43	18	22.5	70
AU RD 76 54...	NL76...R	76	193	41.2	119.1	123	27.2	33	141.2	80	100.6	57	20	36.5	98
AU RD 120 54...	NL120...R	120	240	38.5	163.1	167	24.5	33	182.5	80	119.8	111.3	20	36.5	98

Please see other table for dimensions C, D, E & L

**For dimensions & specifications of the AC Motor, Worm Gearbox & Drive Flange see pages 50-51**

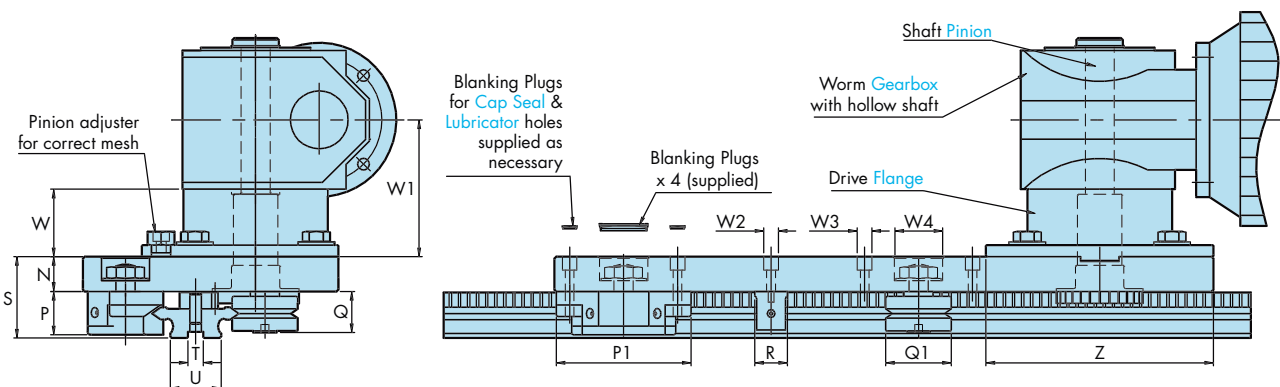
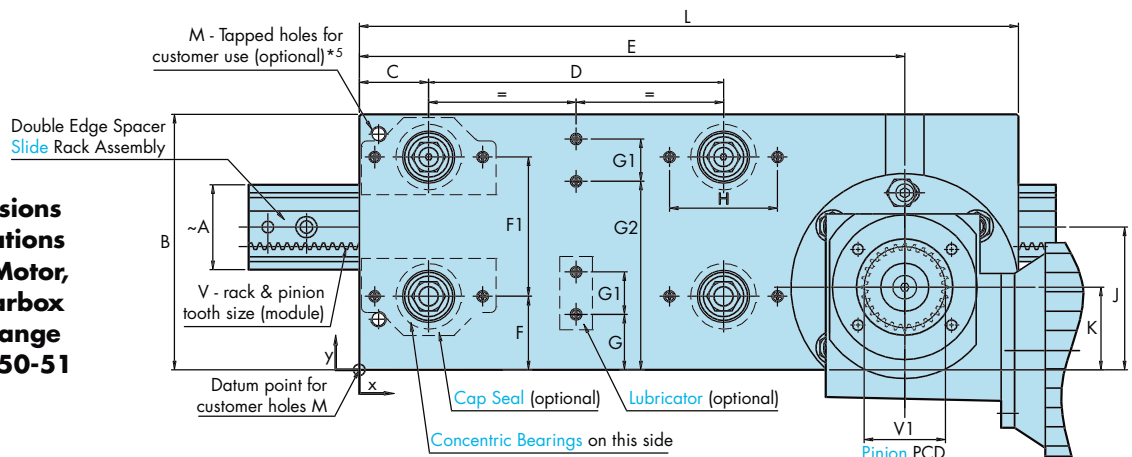

### \* Notes:

1. The maximum load capacities quoted on the Standard and Removable [Carriage](#) pages, assume lubrication at the interface of [Bearings](#) and [Slide](#). This can best be achieved by using [Cap Seals](#) or [Lubricators](#). It is strongly recommended that load and life are determined using methods shown in the [Calculations](#) section.
2. Some dimensions will vary by the amount of the grinding allowance according to the grade of [Slide](#) selected. All [Carriages](#) are compatible with all grades of [Slide](#).
3. CH (Controlled Height) [Bearings](#) are selected to be within  $\pm 0.005$  mm in respect of 'B1' dimension on pages 32-33 compared to Standard [Bearings](#) which are within  $\pm 0.025$  mm. Customers requiring CH [Bearings](#) with the same tolerance band in respect of a number of [Carriages](#) should state this on their order.
4. The Carriage [Bearing](#) and [Cap Seal](#) fixing centres F1 are optimised for use with any precision grade of [Slide](#). Customers making their own carriage plate should calculate their drilling centres for the particular grade of [Slide](#) selected. Please see Assembled Systems or individual component page for details of calculations.
5. Any number and size of tapped mounting holes 'M' can be provided in any available position. These may be specified in the ordering details after the designation M by stating the co-ordinates X & Y relative to the datum point, followed by the tapped hole size. **Example:** M - X10Y25M6 - x=10 mm, y=25 mm, hole size = M6. Care should be taken to avoid any hole position that bridges the contact area between [Cap Seal](#) and carriage plate as this will allow grease to escape.
6. The removable option is not available in conjunction with [Cap Seals](#) or Controlled Height [Bearings](#).
7. The quoted rack drive force is determined by the rack and [pinion](#) size, [gearbox](#) bearings and gears, and the duty. See pages 64-65 for full details.

# Rack Driven Carriages



Carriages may be specified as the Removable type which incorporates Double Eccentric Bearings and allows the disengagement of the Carriage from the Slide at any position along its length without the need for complete disassembly. Rack Driven Carriages are normally supplied as Assembled Units (AU type) which are factory assembled and set to the Slide. More specific information regarding the options for Bearings, lubrication devices and load capacities is given on the pages for both Standard and Removable Carriages\*<sup>1</sup>. For details of linear drive performance, please see the Calculations section. For best performance, the teeth should be lubricated with No. 2 consistency lithium soap-based grease.

**See Application Example on page 11**

Q	Q1	R	S		T	U		V	V1	W	W1	W2	W3	W4	Z	Rack Drive Force/N <sup>*7</sup>
			P1	P2 & P3		P1 & P2	P3									
21.3	34	17	42	42.25	8	26	26.5	1.5	42	35	71	5.4	7.5	25	118	400
21.3	34	17	42	42.25	10	42	42.5	1.5	42	35	71	5.4	7.5	25	118	400
21.3	34	17	42	42.25	12	58	58.5	1.5	42	35	71	5.4	7.5	25	118	400
34.7	54	25	58.5	58.75	15	50	50.5	2	54	34.5	72.5	6.5	9.5	32	147	700
34.7	54	25	58.5	58.75	45	94	94.5	2	54	34.5	72.5	6.5	9.5	32	147	700

## Specifying the Format and Size of the Carriage

3 styles of Carriage are available with motor mounting positions as shown in the diagram below. The style and size are specified by selecting the required values for dimensions C, D, E, & L in the table below the diagram. Any values for these dimensions may be chosen subject to the recommended limitations in the table. If Lubricators are specified with style 2 Carriage, these will be offset to one another as indicated in the diagram.

The motor and gearbox can be mounted in any one of 8 orientations. Please see next page for details.

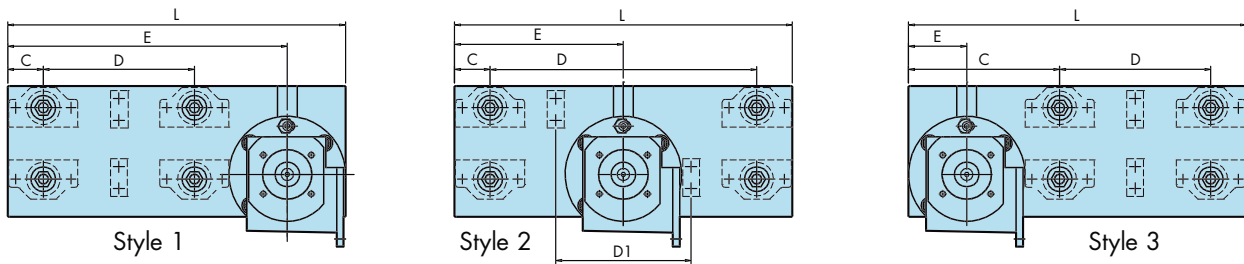

Carriage Style	Part Number	Minimum Recommended Values								
		With Cap Seals				With Lubricators				
		C	D	E	L	C	D	D1	E	L
Style 1	AU RD...34...	36	F1	C+D+92*	E+60	18	F1	-	C+D+73*	E+60
	AU RD...54...	51	F1	C+D+119*	E+75	28	F1	-	C+D+91*	E+75
Style 2	AU RD...34...	36	182*	C+92*	C+D+36	18	177*	124	C+89*	C+D+18
	AU RD...54...	51	237*	C+119*	C+D+51	28	235*	154	C+118*	C+D+28
Style 3	AU RD...34...	E+92*	F1	59	C+D+36	E+73*	F1	-	59	C+D+18
	AU RD...54...	E+119*	F1	73.5	C+D+51	E+91*	F1	-	73.5	C+D+28

Figures marked \* are the minimums which can be achieved without the flange covering the Bearing stud counterbore or the Cap Seal or Lubricator fixings. Smaller values of these dimensions can be achieved if overlap is acceptable to the customer. When specifying such reduced dimensions, the customer should ensure that the Pinion does not interfere with either Bearings, Cap Seals or Lubricators.

## Ordering Details

**AURD4434 L288 C36 D100 E228 (M) (R) (DR) (NS) (CH) (CS) (T)**

Part Number **AURD...**  
**AU...** = Assembled Carriage  
 Carriage Length 'L' = 288 mm  
 Dimension 'C' = 36 mm  
 Dimension 'D' = 100 mm  
 Dimension 'E' = 228 mm  
**M** - Customer mounting holes\*<sup>5</sup>  
 Leave blank if not required  
**R** for Removable Carriage Option  
 Leave blank if not required\*<sup>6</sup>  
**T** = Tamper Proof option  
 Leave blank if not required  
 Lubrication Options:  
**CS** for Cap Seals or **LB** for Lubricators  
 Leave blank if not required  
**CH** = Controlled Height Bearings\*<sup>3</sup>  
 Leave blank if not required  
**NS** = Nitrile Sealed Bearings  
 Leave blank if not required  
**DR** = Double Row Bearings - Leave blank if not required

**AC Motor/Worm Gearbox** page 50-51 - Please state part number as the second line of your order.

**Double Edge Spacer Slide Rack Assembly** page 24-25 - Please state part number as the third line of your order.

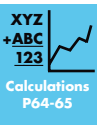

# Gearboxes, AC Geared Motors & Drive Flanges



Linear motion systems incorporating a Hepco [Rack and Pinion](#) will need a means to drive the pinion. The Hepco Gearboxes, AC Geared Motors & Drive Flanges provide this function for [Rack Driven Carriages](#). The same Gearboxes, Geared Motors & Drive Flanges can also be used with Separate [Racks](#) or Rack Cut Single Edge [Spacer Slides](#) to provide a simple, and easily adjustable linear drive.

The Drive Flange which connects the gearbox to the carriage incorporates a unique micro-adjustment facility for achieving correct engagement of the [pinion](#) with the rack. Customers using the Drive Flange in conjunction with a carriage of their own construction will need to provide a keyway to accommodate the sliding key portion P1 (see [Rack Driven Carriage](#) for principle).

To obtain the best performance from the rack and pinion drive, it is important that the meshing teeth are lubricated. A No. 2 lithium soap-based grease is recommended for this purpose. In dirty environments, it is advisable to guard against ingress of debris.

The worm gearboxes are available in ratios from 5:1 to 80:1. Each uses a hardened and ground worm shaft running with a centrifugally cast bronze wheel, with oil bath lubrication. The wheel shaft is supported on high capacity rolling bearings in a high strength aluminium casting. This makes the gearbox strong, accurate, quiet and long lasting. It is also much lighter in weight and more compact than comparable units, making it particularly well suited for dynamic applications. Their low

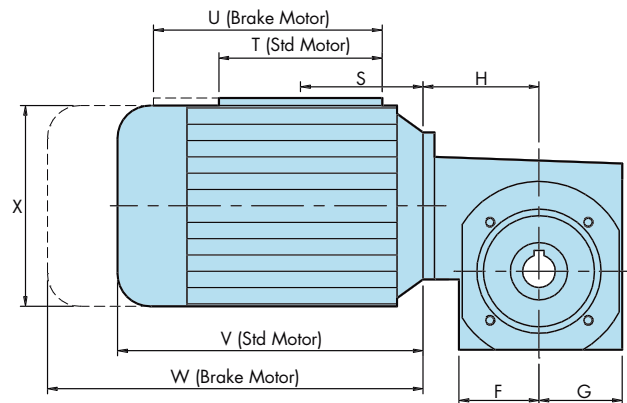
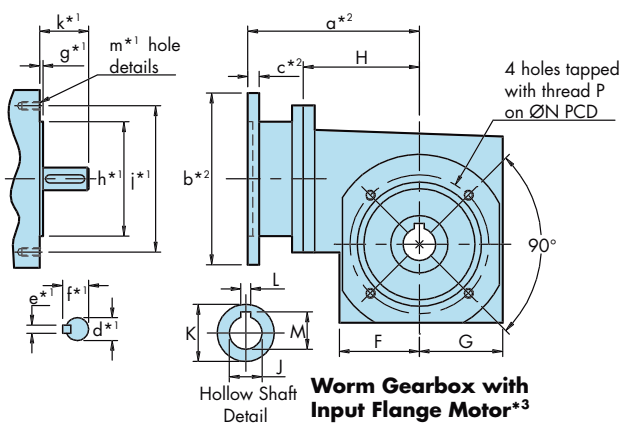

Gearbox/AC Geared Motor Part Number	A	B	C	D	E	F	G	H	J	K	L	M	N	P		Gearbox Rated Output Torque		
	Ø	Depth	Q	R														
WG3	72	75	77	38	33	39	41	57	15	25	5	17.3	62.5	M5	10	67	69	17Nm (typical)
WG4	76	80	82	48	40	49	51	71	20	35	6	22.8	85	M6	12	85	76	32Nm (typical)

Motor Frame Size <sup>*4</sup>	Use with Gearbox	S	T	U	V	W	X	Y	Z	Power			
		2 Pole 'S'	2 Pole 'L'	4 Pole 'S'	4 Pole 'L'								
56	WG3	60	90	130	167	210	111	100	109	90 W	120 W	60 W	90 W
63	WG3 & WG4	65	100	140	187	247	123	100	113	180 W	250 W	120 W	180 W
71	WG3 & WG4	65	100	140	212	272	138	110	125	370 W	550 W	250 W	370 W

Drive Flange Part Number	Use with Gearbox	A1	B1	C1	D1	E1	F1	G1	H1	J1	K1	L1	M1	N1	P1	Q1	R1	S1	T1	Weight
		WG3...	118	35	75	63	75	9	2	49	14	M5	5	6	48	20	2	4	57	43
WG4...	147	34.5	100	88.8	88.8	9	5	62.8	17	M6	6	6	70	25	3	5	76	57	0.5 kg	

The AC Geared Motor and Worm Gearbox may be mounted onto a [Rack Driven Carriage](#) in any one of the 8 configurations shown below. The terminal box may take one of 4 positions A...D and the cable exits also have 4 possible positions 1...4. Please use the diagram below as a guide to selection.

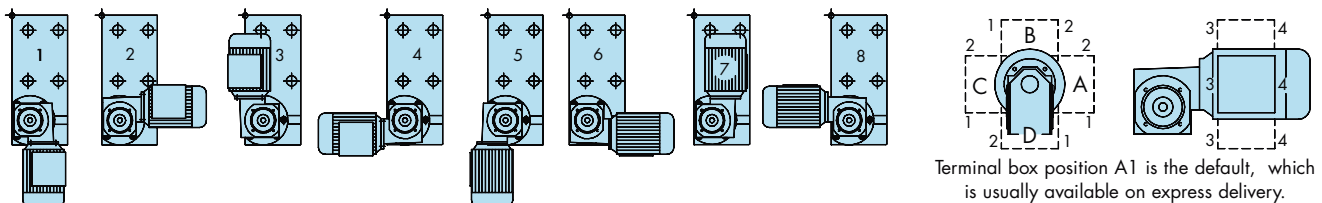

### \* Notes:

1. The customer's motor dimensions marked \*1 on the drawing should be advised to Hepco when the input motor flange option is required.
2. The gearbox input flange dimensions marked \*2 on the drawing will be advised to the customer by Hepco once motor details (see above) have been given.
3. The motor of the standard AC geared motor package is integral with the gearbox, saving space, weight & cost, and cannot be removed by the user. Customers who require that the motor should be separable from the gearbox should specify the worm gearbox, and request that a separate motor be fitted. Hepco can supply a range of suitable motors for such requirements.
4. Other motor sizes beyond those listed are available from Hepco, but may not be compatible with the Drive Flange. Please consult Hepco.

# Gearboxes, AC Geared Motors & Drive Flanges



backlash and high strength make them suitable for use with servo and stepper motors as well as AC motors.

When sold separately, Worm Gearboxes have an input flange and shaft coupling which will be tailored to suit the shaft and face details of the customer's motor.

Gearboxes and geared motors may be specified with an adjustable torque limiting clutch if required.

For the AC motors, Hepco supplies 3 phase squirrel cage type to VDE 0530 supported by DIN 42677. Motors in 3 IEC frame sizes from 56 to 71 can be supplied, each with the choice of short or long field windings and 2 or 4 pole designs (running at approximately 2800 and 1400 rpm respectively). Power ratings from 60W to 0.55kW are available. Motors are rated at 400/230V, are protected to IP54, and are finished in blue epoxy paint as standard. Motors with fitted disk brakes, alternative single and three phase windings, special finishes and enhanced IP protection rating are available on request.

The AC geared motor provides a very cost effective linear drive for simple point-to-point applications, and can easily be teamed up with the Hepco [AC Speed Controller](#) to provide a complete drive control system.

Please see the [Calculations](#) section for details of linear drive performance.

**See Application Examples on pages 11 & 13**

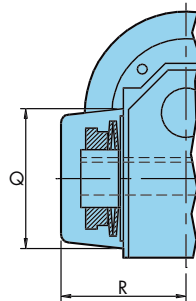
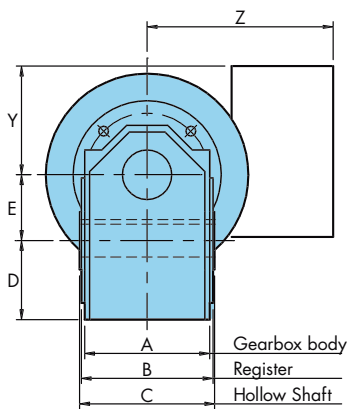

**Torque Limiter Option**

**Drive Flange**

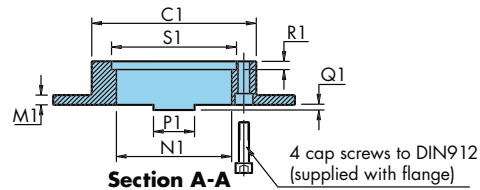
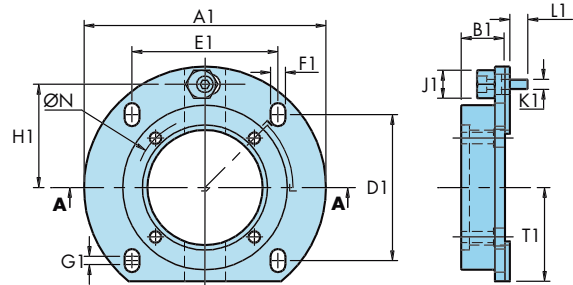

**Section A-A**

Available Ratios	Weight of Gearbox with Input Flange for Motor
5, 7, 10, 12, 15, 18, 24, 30, 38, 50, 75:1	1.6 kg
6, 7.5, 8, 10, 12, 15, 20, 25, 30, 40, 50, 60, 70, 80:1	2.5 kg

Weight of AC Geared Motor with Gearbox size			
WG3 'S' Motor	WG3 'L' Motor	WG4 'S' Motor	WG3 'L' Motor
4.5 kg	4.7 kg	-	-
4.8 kg	5.3 kg	5.6 kg	6.1 kg
6.8 kg	7.8 kg	7.6 kg	8.6 kg

**Section of Assembled Gearbox, Flange & Pinion**

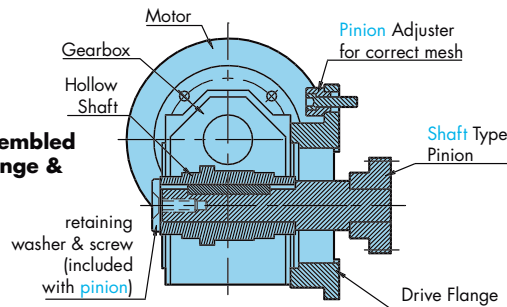

## Ordering Details for AC Geared Motor & Worm Gearbox

**WG3 R30 (T) (4) M 56 (L) (2) (B) (A) (1)**

Part Number \_\_\_\_\_  
 Gearbox Reduction Ratio (**R30** = 30:1) \_\_\_\_\_  
**T** = Optional Torque Limiter \_\_\_\_\_  
 Leave blank if not required \_\_\_\_\_  
 Gearbox mounting position \_\_\_\_\_  
 Choose 1-8 or leave blank for unassembled\*<sup>2</sup> \_\_\_\_\_  
 Input Options: **F** = Flange\*<sup>1,2</sup>; **M** = fitted AC Motor \_\_\_\_\_

Cable Exit Position: choose **1-4** \_\_\_\_\_  
 Terminal Box Position: choose **A-D** \_\_\_\_\_  
**B** = Brake Motor \_\_\_\_\_  
 Leave blank if not required \_\_\_\_\_  
 Motor Poles: 2 = ~2800RPM or 4 = 1400RPM \_\_\_\_\_  
 Motor field winding: **S** = short or **L** = long \_\_\_\_\_  
 Motor frame size: **56, 63** or **71**\*<sup>4</sup> \_\_\_\_\_

These items only apply if AC motor is required.

**Drive Flange\*** \_\_\_\_\_ Please state part number as second line of the order (see table above left).

**Shaft Pinion\*** \_\_\_\_\_ Please state part number as third line of the order (see page 45).

\* Customers requiring Geared Motor or Worm Gearbox for use with [Rack Driven Carriages](#) should not specify Drive Flange or Shaft Pinion as they are included as standard.

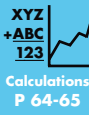



# AC Speed Controller

In addition to the AC Motor which may be used to power the Rack Driven Carriage and other driven systems, Hepco will supply the speed controller and switches necessary to position and dynamically control the linear movement. This enables the customer to buy a complete system from a single supplier at a competitive price, safe in the knowledge that all aspects have been included within the design.

The model and details of the AC speed controller will depend on the application. Each type has been selected to match the requirements of the range of AC Geared Motors, and the functionality which is required in point-to-point linear applications using rack or belt transmissions.

Full details on each model of AC speed controller are included in a separate technical catalogue, which is available from Hepco. The units have the following characteristics which make them ideally suited for use within AC linear positioning systems:

- Ideally suited for Hepco rack and belt driven systems.
- Available from Hepco at a competitive price.
- Units are manufactured by a leading international supplier, with full support in all major markets.
- Drives from 0.37 - 4.0 kW will power a wide range of 3 phase AC induction motors.
- Speeds, acceleration rates, power boost functions and motor braking may be programmed.
- Environmental protection to IP20. Can be located inside an enclosure to achieve any higher rating.
- Keypad programming and digital display of program and running parameters.
- Easy to install and commission.
- Compact unit may be panel mounted or fixed onto a DIN rail.
- Options allow for analogue control via a voltage input or potentiometer, or via digital preset speeds which can be menu programmed or accessed via external switches or a separate PLC.
- Drives are available to run from 230-250 V single phase or 380-460 V three phase supplies.
- Units will be supplied with filters to meet the requirements of the EU EMC directive.
- Units may be specified with Devicenet compatible interface for high level control communications.
- On board diagnostics for easy fault finding.
- The simple and economical solution for basic point-to-point linear positioning applications.





Motor Sizes	Required Controller Power
80 L/2	1.5 kW
80 S/2 & 80 L/4	0.75 kW
80 S/4 & 71L/2	0.55 kW
71 L/4, 71 S/2 & 71 S/4 all 56 & 63 frame motors	0.37 kW

### AC Speed Controller

Depending on the application, the model may differ from that shown. Please contact Hepco for a full technical catalogue and application advice.

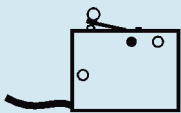
In addition to the AC speed controller, Hepco supplies mechanical and inductive limit switches, sealed to IP67. These will usually be required as part of the control hardware of a typical installation.

Description	Part Number	Lead Length
 Standard V3 pattern roller actuated microswitch	DLS-V7SWM	500 mm
 Standard V3 pattern inductive switch	DLS-V7SWI	500 mm



## Application Recommendations

The Hepco AC geared motor/AC speed controller method of driving and controlling a linear movement is generally far less expensive than using stepper or servo motor systems.

Customers are therefore recommended to consider whether the performance and sophistication of their application can be satisfied by Hepco's AC drive equipment before opting for more expensive alternatives. To aid this decision, the following general information is provided to explain what can be achieved by using a Hepco AC geared motor and speed control system:

The drawing below shows the switch control for a typical point to point linear movement with security switches/crash protection devices in place. Additional speeds during the stroke cycle can be achieved by adding more switches wired through to the controller.

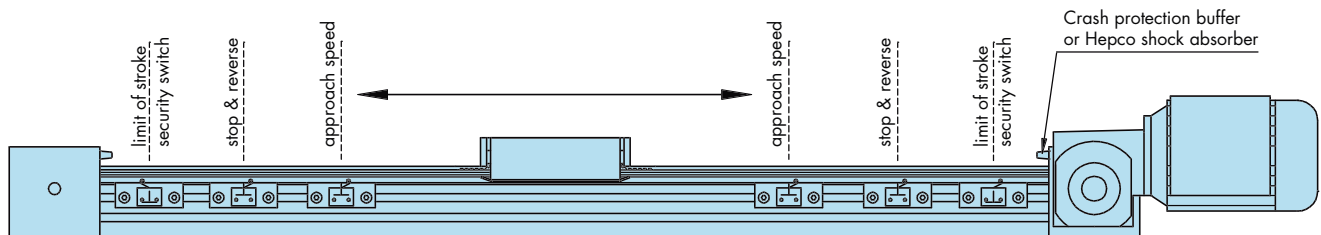

### Function and Performance

The AC system can stop, start, reverse, accelerate and decelerate. Dynamic braking of the motor is also possible. In conjunction with a simple PLC, it can dwell at any switch position and perform more sophisticated accelerations as well as giving output command signals to other equipment.

The signals for initiating the basic functions are provided by means of either mechanical or inductive switches which Hepco supply (see table on page 52, left).

Stop position repeatability can be better than 1 mm and is dependent upon slowing down to a low approach speed before reaching the stop switch (if the approach speed is too fast for the load being carried, the motor will overrun the stop switch position).

Several individual pre-set speeds can be selected each with its own acceleration/deceleration profile. These speeds are variable over a very wide range and can be easily set.

The AC system is a simple, reliable, low cost method of driving and control but it does not have the facility for continuous feedback to regulate the exact position of the movement at all times. Continuous feedback is necessary if monitoring and control of the precise dynamic relationship of two or more axes of a machine is required, or if it is necessary to perform a specific dynamic profile with very accurate repeatability. Continuous feedback is a feature of servos and some stepper motor systems.

### Fail-safe Requirements

In any powered linear system it is necessary to consider the consequences of system failure. Failure to stop at the end of stroke may result in damage to the system and to other equipment and could also present a safety hazard.

It is therefore recommended that the linear transmission includes two levels of safety:

**Limit of stroke security switches** - These should be fitted outboard of the normal end of stroke switches in order to switch off the motor should the linear transmission travel beyond the operating limits which have been set.

**Crash protection** - It is recommended that devices be fitted at the limit of physical travel to absorb the energy of the moving load in the event of high speed overrun of the switches.

Crash protection devices may be simple buffers made from energy absorbing material, but in applications where a high degree of protection is necessary, it is recommended that Hepco Shock Absorbers be fitted (please apply for separate catalogue).

### Additional Safety Considerations

In many applications, the standard AC motor can be used to dynamically brake the system. In some applications, particularly lifting, a holding brake may also be required. This provides an additional degree of safety and may be used as part of the normal operating cycle. In these cases, the optional braked AC motor should be specified.

All Hepco GV3 linear motion components are intended to be used as parts of a larger machine. Depending on the application, there may be potential hazards which need to be considered and addressed as appropriate such as guarding of high speed movements and elimination of hazards due to electrical shock or malfunction.

If the driving force is provided by a reinforced toothed belt or other means of transmission which could snap beyond a certain load, the customer should ensure that loads approaching the maximum will not be exceeded under any circumstances, or that no safety hazard will result from such breakage.

# Data & Dimensions for Assembled Systems

Hepco GV3 Slide Systems may be ordered either as individual components or as factory assembled systems. For details of the extensive range of factory assembled Standard, Slimline, Removable, Belt Driven and Rack Driven Carriages, please refer to the pages indicated by the icons in the margin.

The Assembled Systems Pages include summary data on Slides, Bearings and Lubrication Devices. They allow customers to calculate the overall dimensions of a system (less carriage plate) and provide important reference dimensions including drilling

## Standard Bearing Range

### Slides with Through Hole Fixing Bearings

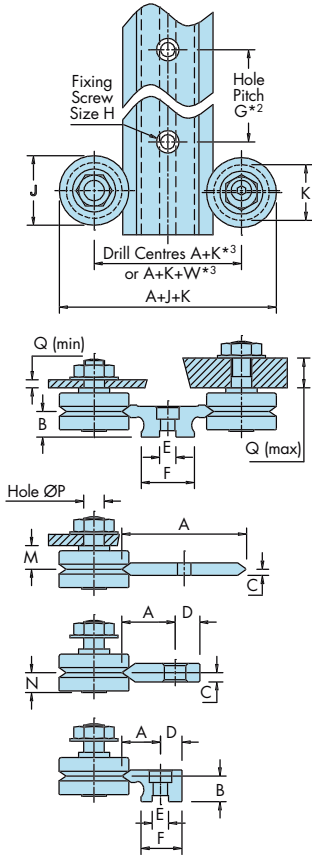

### Slides with Blind Hole Fixing Bearings

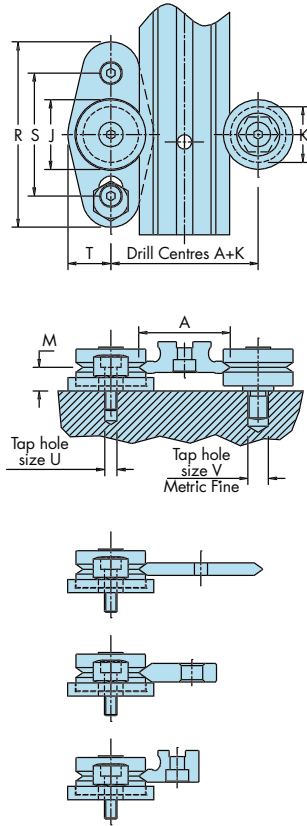

### Slides with Cap Seals

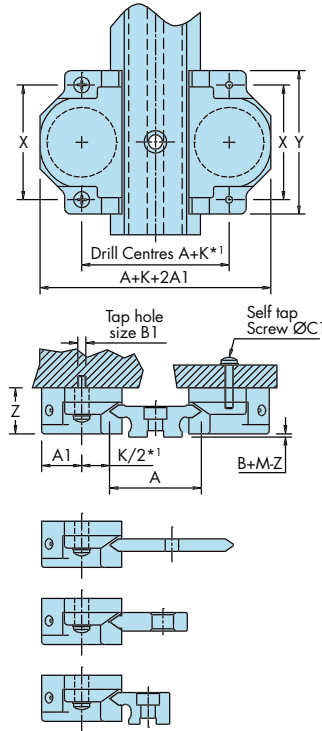

### Slides with Lubricators

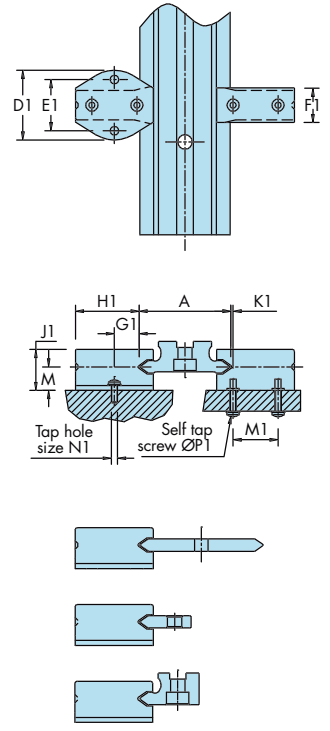

'Mix & Match' Component Compatibility Chart

✓ = Preferred choice    ✓ = Compatible    X = Not Compatible

	CS18	CS25	CS34	CS54	LB12	LB20	LB25	LB44	LB76	J195...	J265...	J580...	CW195	CW265	CW360	CW580	LB195	LB265	LB360	LB580	
J13...	✓	✓	✓	✓	✓	✓	✓	✓	✓	✓	✓	✓	✓	✓	✓	✓	✓	✓	✓	✓	✓
J18...	✓	✓	✓	✓	✓	✓	✓	✓	✓	✓	✓	✓	✓	✓	✓	✓	✓	✓	✓	✓	✓
J25...	✓	✓	✓	✓	✓	✓	✓	✓	✓	✓	✓	✓	✓	✓	✓	✓	✓	✓	✓	✓	✓
J34...	✓	✓	✓	✓	✓	✓	✓	✓	✓	✓	✓	✓	✓	✓	✓	✓	✓	✓	✓	✓	✓
J54...	✓	✓	✓	✓	✓	✓	✓	✓	✓	✓	✓	✓	✓	✓	✓	✓	✓	✓	✓	✓	✓

Part Number	A		B		C		D		E		F		G	H
	P1 & P2	P3	P1	P2 & P3	P1	P2 & P3	P1 & P2	P3	P1 & P2	P3				
NMS 12...	12.37	13.25	6.2	6.4	-	-	-	-	4	8.5	8.9	45	M3	
NV 20...	20.37	21.01	8	8.2	-	-	-	-	5	12	12.4	90	M4	
NV 28...	28.37	29.01	8	8.2	-	-	-	-	6	20	20.4	90	M5	
NS 25...	25.74	26.58	10	10.2	-	-	-	-	6	15	15.4	90	M5	
NS 35...	35.74	36.38	10	10.2	-	-	-	-	8	25	25.4	90	M6	
NS 50...	50.74	51.38	10	10.2	-	-	-	-	10	40	40.4	90	M6	
NM 44...	44.74	45.58	12.5	12.7	-	-	-	-	8	26	26.4	90	M6	
NM 60...	60.74	61.38	12.5	12.7	-	-	-	-	10	42	42.4	90	M8	
NM 76...	76.74	77.38	12.5	12.7	-	-	-	-	12	58	58.4	90	M8	
NL 76...	76.74	77.58	19.5	19.7	-	-	-	-	15	50	50.4	180	M12	
NL 120...	120.74	121.38	19.5	19.7	-	-	-	-	45	94	94.4	180	M10	

✓	✓	✓	✓	✓	✓	✓	✓	✓	✓	✓	✓	✓	✓	✓	✓	✓	✓	✓	✓	✓	✓
✓	✓	✓	✓	✓	✓	✓	✓	✓	✓	✓	✓	✓	✓	✓	✓	✓	✓	✓	✓	✓	✓
✓	✓	✓	✓	✓	✓	✓	✓	✓	✓	✓	✓	✓	✓	✓	✓	✓	✓	✓	✓	✓	✓
✓	✓	✓	✓	✓	✓	✓	✓	✓	✓	✓	✓	✓	✓	✓	✓	✓	✓	✓	✓	✓	✓
✓	✓	✓	✓	✓	✓	✓	✓	✓	✓	✓	✓	✓	✓	✓	✓	✓	✓	✓	✓	✓	✓

NMS E...	6.19	6.41	6.2	6.4	-	-	5	5.3	4	9.25	9.65	45	M3
NV E...	9.69	10.02	8	8.2	-	-	6.5	6.7	4	12	12.4	90	M4
NS E...	12.87	13.19	10	10.2	-	-	8.5	8.7	6	16	16.4	90	M5
NM E...	18.87	19.19	12.5	12.7	-	-	10.5	10.7	8	20	20.4	90	M6
NL E...	27.37	27.69	19.5	19.7	-	-	16	16.2	12	30	30.4	180	M10

✓	✓	✓	✓	✓	✓	✓	✓	✓	✓	✓	✓	✓	✓	✓	✓	✓	✓	✓	✓	✓	✓
✓	✓	✓	✓	✓	✓	✓	✓	✓	✓	✓	✓	✓	✓	✓	✓	✓	✓	✓	✓	✓	✓
✓	✓	✓	✓	✓	✓	✓	✓	✓	✓	✓	✓	✓	✓	✓	✓	✓	✓	✓	✓	✓	✓
✓	✓	✓	✓	✓	✓	✓	✓	✓	✓	✓	✓	✓	✓	✓	✓	✓	✓	✓	✓	✓	✓
✓	✓	✓	✓	✓	✓	✓	✓	✓	✓	✓	✓	✓	✓	✓	✓	✓	✓	✓	✓	✓	✓

MS 12...	12.55	13.13	-	-	1.52	1.60	-	-	-	-	-	30	M3
V 20...	20.37	21.01	-	-	2.14	2.21	-	-	-	-	-	90	M4
V 28...	28.37	29.01	-	-	2.14	2.21	-	-	-	-	-	90	M5
S 25...	25.81	26.58	-	-	2.39	2.47	-	-	-	-	-	90	M6
S 35...	35.81	36.58	-	-	2.39	2.47	-	-	-	-	-	90	M6
S 50...	50.82	51.58	-	-	2.39	2.47	-	-	-	-	-	90	M6
M 44...	44.81	45.58	-	-	3.14	3.21	-	-	-	-	-	90	M6
M 60...	60.81	61.58	-	-	3.14	3.21	-	-	-	-	-	90	M8
M 76...	76.81	77.38	-	-	3.14	3.21	-	-	-	-	-	90	M8
L 76...	76.81	77.58	-	-	4.56	4.72	-	-	-	-	-	90	M10
L 120...	120.81	121.58	-	-	4.56	4.72	-	-	-	-	-	180*	M10*

✓	✓	✓	✓	✓	✓	✓	✓	✓	✓	✓	✓	✓	✓	✓	✓	✓	✓	✓	✓	✓	✓
✓	✓	✓	✓	✓	✓	✓	✓	✓	✓	✓	✓	✓	✓	✓	✓	✓	✓	✓	✓	✓	✓
✓	✓	✓	✓	✓	✓	✓	✓	✓	✓	✓	✓	✓	✓	✓	✓	✓	✓	✓	✓	✓	✓
✓	✓	✓	✓	✓	✓	✓	✓	✓	✓	✓	✓	✓	✓	✓	✓	✓	✓	✓	✓	✓	✓
✓	✓	✓	✓	✓	✓	✓	✓	✓	✓	✓	✓	✓	✓	✓	✓	✓	✓	✓	✓	✓	✓

MS E...	6.87	7.1	-	-	1.52	1.60	4.5	4.7	-	-	-	45	M3
V E...	10.37	10.6	-	-	2.14	2.21	6	6.2	-	-	-	90	M4
S E...	12.96	13.3	-	-	2.39	2.47	6.5	6.7	-	-	-	90	M5
M E...	17.46	17.8	-	-	3.14	3.21	8	8.2	-	-	-	90	M6
L E...	22.46	22.8	-	-	4.56	4.72	10	10.2	-	-	-	90	M6

✓	✓	✓	✓	✓	✓	✓	✓	✓	✓	✓	✓	✓	✓	✓	✓	✓	✓	✓	✓	✓	✓
✓	✓	✓	✓	✓	✓	✓	✓	✓	✓	✓	✓	✓	✓	✓	✓	✓	✓	✓	✓	✓	✓
✓	✓	✓	✓	✓	✓	✓	✓	✓	✓	✓	✓	✓	✓	✓	✓	✓	✓	✓	✓	✓	✓
✓	✓	✓	✓	✓	✓	✓	✓	✓	✓	✓	✓	✓	✓	✓	✓	✓	✓	✓	✓	✓	✓
✓	✓	✓	✓	✓	✓	✓	✓	✓	✓	✓	✓	✓	✓	✓	✓	✓	✓	✓	✓	✓	✓

# Data & Dimensions for Assembled Systems

details. The information can be determined for any combination of components as indicated in the Mix and Match table enabling customers to design a system to meet their exact requirements.

Dimensions in respect of the additional components used in Slide Beams, Belt Driven Carriages and Rack Driven Carriages may be found on the pages relating to these products.

## Slimline Bearing Range

### Slides with Through Hole Fixing Bearings

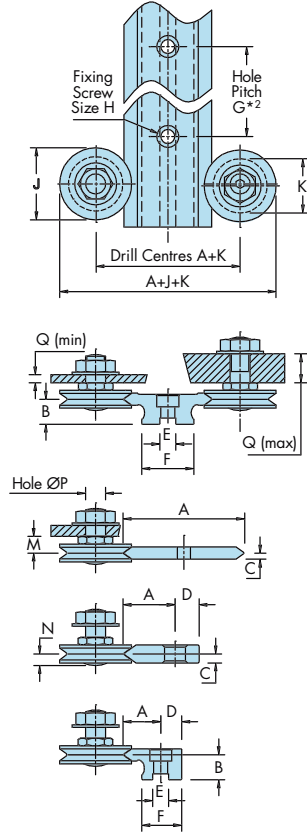

### Slides with Blind Hole Fixing Bearings

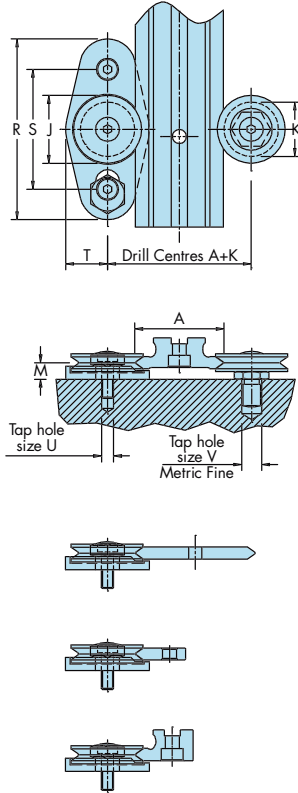

### Slides with Cap Wipers

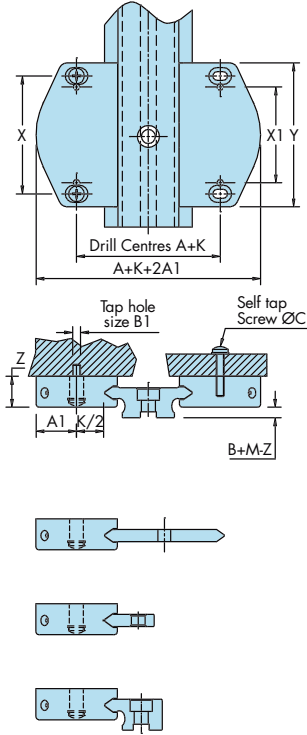

### Slides with Lubricators

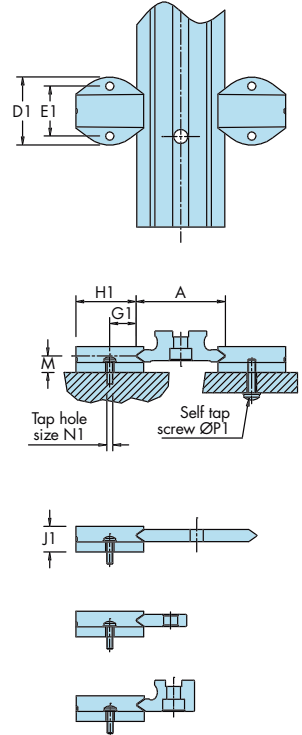

Part Number	J	K	M	N	P	Q (short Stud)		Q (long Stud)		R	S	T	U	V Metric Fine	W
						min	max	min	max						

	...J13...	12.7	9.51	5.47	4.5	4	2.2	3	2.4	6.7	47.5	30	10	M3	M4 x 0.5	1.34
	...J18...	18	14.0	6.75	5.6	6	2.4	3.4	2.5	10	54	38	12.3	M4	M6 x 0.75	1.84
	...J25...	25	20.27	9.0	7.5	8	2.2	3.8	4.9	13	72	50	16	M5	M8 x 1	1.95
	...J34...	34	27.13	11.5	9.7	10	5.2	6.6	5.9	14.8	90.5	60	21	M6	M10 x 1.25	2.55
...J54...	54	41.8	19.0	15.6	14	5.7	8.2	7.9	20.4	133	89.5	31	M8	M14 x 1.5	3.89	

	...J195...	19.5	14.8	5.7	3.5	6	2.4	3.4	2.5	10	54	38	12.3	M4	M6 x 0.75	-
	...J265...	26.5	20	6.8	4.5	8	2.2	3.8	4.9	13	72	50	16	M5	M8 x 1	-
	...J360...	36	27.6	8.3	5.7	10	5.2	6.6	5.9	14.8	90.5	60	21	M6	M10 x 1.25	-
	...J580...	58	46.1	14.3	8.5	14	5.7	8.2	7.9	20.4	133	89.5	31	M8	M14 x 1.5	-

Part Number	X	X1	Y	Z	A1	B1	C1	Use with Bearings
-------------	---	----	---	---	----	----	----	-------------------

	CS18	32.5	-	42	13.8	11	M2.5	3	...J18...
	CS25	44	-	55	18	16	M3	3.5	...J25...
	CS34	56	-	70	22.5	21	M4	4.5	...J34...
	CS54	80	-	98	36.5	31	M5	6	...J54...

	CW195	35	27.5	43	11.2	12	M2.5	3	...J195...
	CW265	44	35	54	13	16	M3	3.5	...J265...
	CW360	59	48	72	15.5	21	M4	4.5	...J360...
	CW580	90	74	106	25	32	M5	6	...J580...

Part Number	D1	E1	F1	G1	H1	J1	K1	M1	N1	P1	Use with Bearings
-------------	----	----	----	----	----	----	----	----	----	----	-------------------

	LB12	17	12	7	4.8	11.5	10	1.6	6.5	M2.5	2.5	...J13...
	LB20	19	13	8	7.3	19	12	0.8	13	M2.5	2.5	...J18...
	LB25	25	18	12	9	23	16.5	1	16	M3	3	...J25...
	LB44	34	25	17	11.8	31	20	0.8	22	M4	3	...J34...
	LB76	50	38	25	17.8	47	33.5	1.3	33	M5	3.5	...J54...

	LB195	19	13	-	7.5	17.5	8.7	-	-	M2.5	3	...J195...
	LB265	25	18	-	9.6	23	10.3	-	-	M3	3.5	...J265...
	LB360	34	25	-	13.4	31	12.9	-	-	M4	5	...J360...
	LB580	50	38	-	19.9	49	21.9	-	-	M5	6	...J580...

### \*Notes:

1 The fixing screw positions for the size CS18 Cap Seal are not on the same centre line as the Bearing (see page 36). When using the CS18 please add 3.8 mm to A+K.

2 The NL120 and L120 Slides have 2 parallel rows of holes. See pages 25 & 28.

3 Drilling centres A+K apply to all bearings with the exception of Double Eccentric (DE) type. If Double Eccentric bearings are used with the intention of disengaging the Slide, then drilling centres A+K+W should be used.

Double Eccentric bearings are designed to adjust in with the eccentric making a 45° angle to the Slide as shown below.

### Drilling Positions for DE Bearings

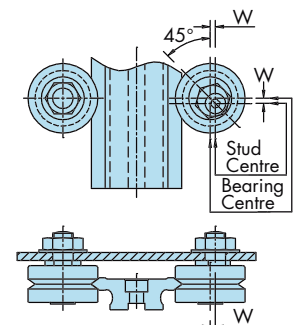

# Data & Dimensions for Assembled Systems

The Assembled Systems Pages include summary data on [Single Edge Spacer Slides](#), [Bearings](#), [Track Rollers](#), [Flat Tracks](#), [Racks](#) and [Pinions](#). They allow customers to calculate the overall dimensions of a system and provide important reference dimensions including drilling details.

It is possible to run a Wide Track Roller on the rear face of the Single Edge Spacer Slide, but this option is not shown, as the Narrow Track Roller usually fits better. The extra load capacity of the Wide Track Roller will not usually be a benefit when used with the Single Edge Spacer Slide, as the soft back face can be damaged if used beyond the load capacity of the Narrow Track Roller.

## Single Edge Spacer Slide with 'V' Bearings and Track Rollers

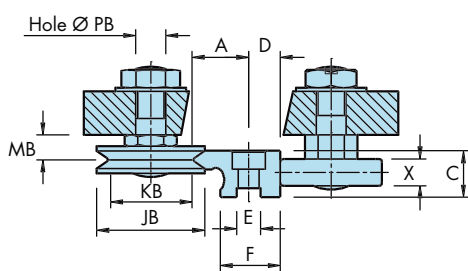
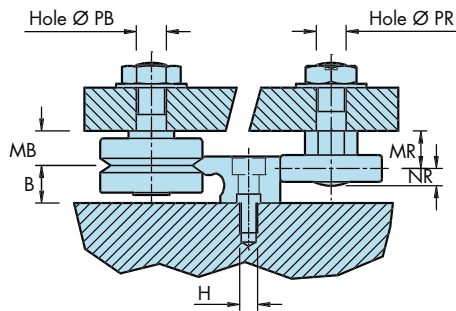
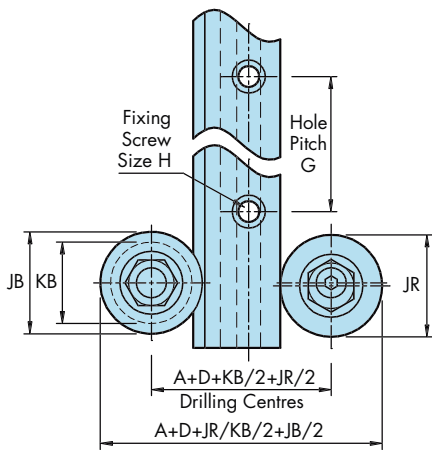

## Single Edge Spacer Slide with 'V' Bearings and Pinions

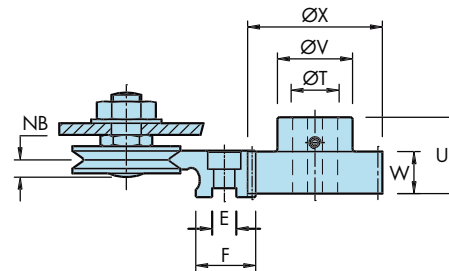
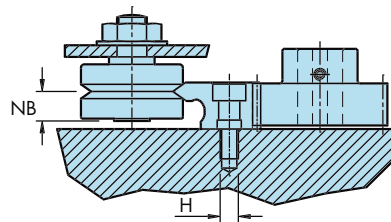
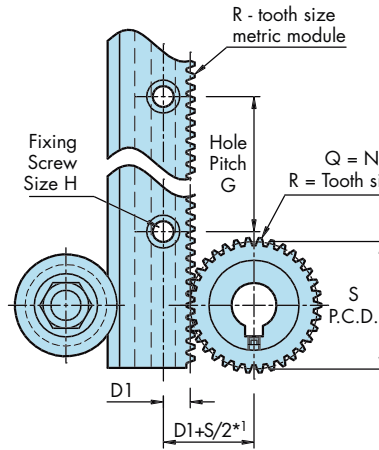

## Racks with Pinions

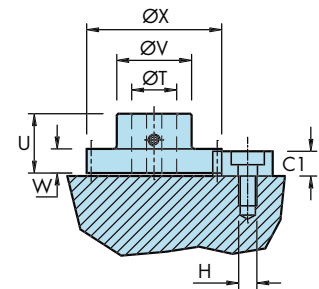
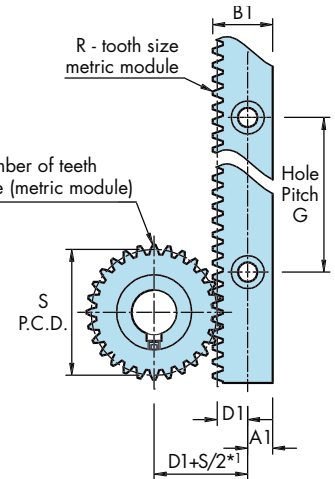

Spacer Slides	Part Number	A		B		C		D		D1	E	F		G	H
		P1 & P2	P3	P1	P2 & P3	P1	P2 & P3	P1 & P2	P3			P1 & P2	P3		
	NMS E...	6.19	6.41	6.2	6.4	7.7	8.1	5	5.3	4.5	4	9.25	9.65	45	M3
	NV E...	9.69	10.02	8	8.2	10.0	10.43	6.5	6.7	5.8	4	12	12.4	90	M4
	NS E...	12.87	13.19	10	10.2	12.25	12.76	8.5	8.7	7.4	6	16	16.4	90	M5
	NM E...	18.87	19.19	12.5	12.7	15.5	15.98	10.5	10.7	9.25	8	20	20.4	90	M6
	NL E...	27.37	27.69	19.5	19.7	24.0	24.49	16	16.2	14.1	12	30	30.4	180	M10

Racks	Part Number	A1	B1	C1	D1	G	H	S
	R 07...	6.35	12.7	4	5.65	45	M4	0.7
	R 10...	7.8	15.65	6.75	6.85	90	M5	1
	R 15...	8.3	20	8.25	10.2	90	M6	1.5
	R 20...	13.2	31.75	14	16.55	90	M10	2

Flat Tracks	Part Number	E1		F1		G	G1		H
		P1 & P2B	P2A & P3	P1 & P2B	P2A & P3		P1 & P2A	P2B & P3	
	FT 24 12	7.5	7.7	16.5	16.7	45	12	12.4	M5
	FT 32 16	8.75	8.95	23.25	23.45	90	16	16.4	M6
	FT 40 20	12	12.2	28	28.2	90	20	20.4	M8
	FT 66 33	17	17.2	49	49.2	180	33	33.4	M12

Pinions	Part Number	No of Teeth	mod	S	T	U	V	X	W
	P07 W9 T28...	28	0.7	19.6	5	17	16	21	9
	P07 W5 T28...	28	0.7	19.6	5	13	16	21	5
	P10 W11 T42...	42	1	42	15	23	30	44	11
	P10 W7 T42...	42	1	42	15	18.5	30	44	7
	P125 W14 T34...	34	1.25	42.5	15	25.5	30	45	14
	P15 W8 T28...	28	1.5	42	15	19.8	30	45	8
	P20 W20 T27...	27	2	54	20	35	40	58	20
	P20 W13 T27...	27	2	54	20	25	40	58	13

# Data & Dimensions for Assembled Systems

All sizes of Track Roller (in both narrow and wide formats) have a 500 mm crown radius to avoid the problems which can occur if imperfect alignment concentrates the load on the edge of the roller.

Any Track Roller can be used with any size of Flat Track or Single Edge Spacer Slide, subject to physical size constraints.

Any Rack and pinion combination can be used, subject to the tooth size matching, and other obvious size constraints.

The drawings show only Boss type pinions. Pinions with integral shafts are also available, see [Pinions](#) page.

## Flat Tracks with Through Hole Fixing Track Rollers

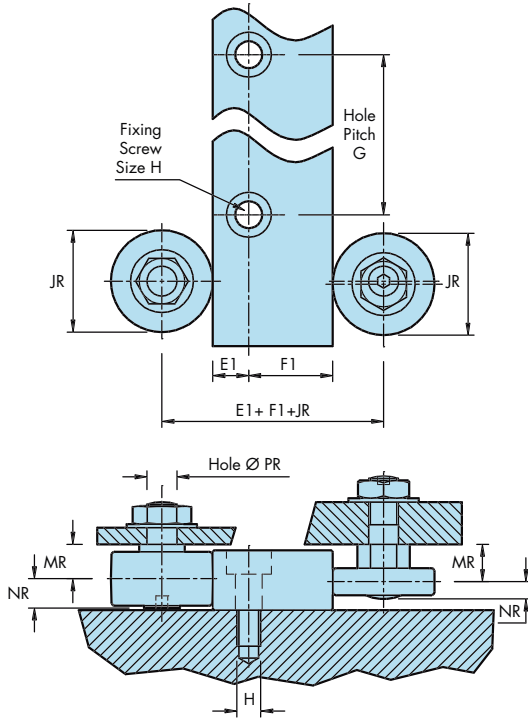

## Flat Tracks with Blind Hole Fixing Track Rollers

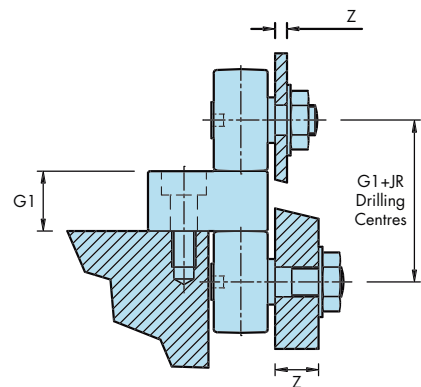
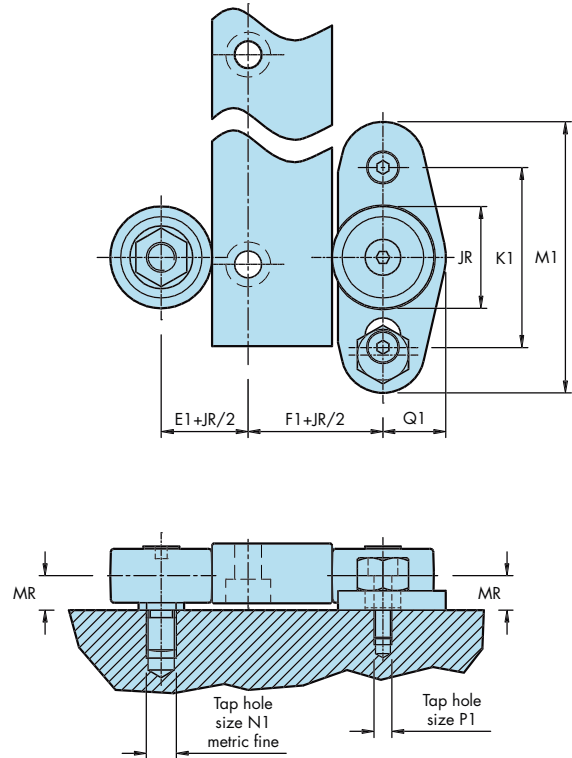

Bearings	Part Number	JB	KB	MB	NB	PB	Z (short stud)		Z (long stud)	
							min	max	min	max
	...J13...	12.7	9.51	5.47	4.5	4	2.2	3	2.4	6.7
	...J18...	18	14.00	6.75	5.6	6	2.4	3.4	2.5	10
	...J25...	25	20.27	9.0	7.5	8	2.2	3.8	4.9	13
	...J34...	34	27.13	11.5	9.7	10	5.2	6.6	5.9	14.8
	...J54...	54	41.76	19.0	15.6	14	5.7	8.2	7.9	20.4
	...J195...	19.5	14.8	5.7	3.5	6	2.4	3.4	2.5	10
	...J265...	26.5	19.98	6.8	4.5	8	2.2	3.8	4.9	13
	...J360...	36	27.57	8.3	5.7	10	5.2	6.6	5.9	14.8
	...J580...	58	46.08	14.3	8.5	14	5.7	8.2	7.9	20.4

Track Rollers	Part Number	JR	MR	NR	PR	Z (short stud)		Z (long stud)		M1	K1	Q1	P1	N1 Metric Fine
						min	max	min	max					
	...R18...	18	6.75	5.6	6	2.4	3.4	2.5	10	54	38	12.25	M4	M6 x 0.75
	...R25...	25	9.0	7.5	8	2.2	3.8	4.9	13	72	50	16	M5	M8 x 1
	...R34...	34	11.5	9.7	10	5.2	6.6	5.9	14.8	90.5	60	21	M6	M10 x 1.25
	...R54...	54	19.0	15.6	14	5.7	8.2	7.9	20.4	133	89.5	31	M8	M14 x 1.5
	LRN18...	18	8	3.5	6	-	-	2.5	10					
	LRN25...	25	10	4.5	8	-	-	4.9	13					
	LRN34...	34	12.5	5.7	10	-	-	5.9	14.8					
	LRN54...	54	21	8.5	14	-	-	7.9	20.4					

### Note:

- The calculated position of the pinion relative to the rack gives an approximate location only. Customers should make provision for the pinion to be adjusted relative to the rack to ensure that the best running condition is achieved. The Hepco [Gearbox and Drive Flange](#) includes a facility for this type of adjustment.



# Load/Life Calculations

## V Slide & Bearing Systems

The load capacity and life of Hepco V Slide Systems will be determined by several factors. The key issues are the size and type of Bearing and Slide, the presence or absence of lubrication and the magnitude and direction of loads.

Other factors including operational speed, length of stroke and environmental conditions may also have an effect\*2.

When calculating the system load and life, one of two approaches should be taken: if the system uses a conventional 4 bearing carriage (such as any of the Hepco Carriages), then this may be treated as a single item, and the load and life be determined as in the **4 Bearing Carriage Calculations** below; alternatively, each V bearing can be treated separately according to the method shown in the **Individual Bearing Calculations** section.

### 4 Bearing Carriage Calculations

When calculating the loading and life of a V Slide System using a 4 bearing carriage, the loading on the system should be resolved into the direct load components, L1 and L2, and the moment loading components M, Mv and Ms (see diagram on right).

The maximum direct and moment load capacities for standard carriages are given in the tables below. Capacities are included for both 'dry' and 'lubricated'\*4 conditions - this refers to the 'V' contact, since all bearings are greased internally for life. Values are based on shock-free duty.

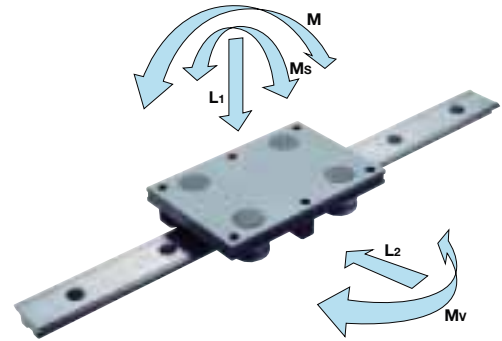

Carriage Part Numbers	Dry System, Twin and DR Type Bearing					Lubricated System, Twin Type Bearing					Lubricated System, DR Type Bearing				
	L1(max)	L2(max)	Ms(max)	Mv(max)	M(max)	L1(max)	L2(max)	Ms(max)	Mv(max)	M(max)	L1(max)	L2(max)	Ms(max)	Mv(max)	M(max)
	N	N	Nm	Nm	Nm	N	N	Nm	Nm	Nm	N	N	Nm	Nm*6	Nm
AU... 12 13...	90	90	0.5	45 x D	45 x D	240	240	1.3	120 x D	120 x D	Not Available				
AU... 20 18...	180	180	1.6	90 x D	90 x D	500	400	4.5	200 x D	250 x D	760	1200	7	600 x D	380 x D
AU... 28 18...	180	180	2.3	90 x D	90 x D	500	400	6.5	200 x D	250 x D	760	1200	10	600 x D	380 x D
AU... 25 25...	400	400	4.5	200 x D	200 x D	1280	1200	14	600 x D	640 x D	1600	3000	18	1500 x D	800 x D
AU... 35 25...	400	400	6.5	200 x D	200 x D	1280	1200	21	600 x D	640 x D	1600	3000	26	1500 x D	800 x D
AU... 50 25...	400	400	9.5	200 x D	200 x D	1280	1200	30	600 x D	640 x D	1600	3000	38	1500 x D	800 x D
AU... 44 34...	800	800	16	400 x D	400 x D	3200	2800	65	1400 x D	1600 x D	3600	6000	73	3000 x D	1800 x D
AU... 60 34...	800	800	22	400 x D	400 x D	3200	2800	90	1400 x D	1600 x D	3600	6000	100	3000 x D	1800 x D
AU... 76 34...	800	800	29	400 x D	400 x D	3200	2800	115	1400 x D	1600 x D	3600	6000	130	3000 x D	1800 x D
AU... 76 54...	1800	1800	64	900 x D	900 x D	7200	6400	250	3200 x D	3600 x D	10000	10000	360	5000 x D	5000 x D
AU... 120 54...	1800	1800	100	900 x D	900 x D	7200	6400	410	3200 x D	3600 x D	10000	10000	580	5000 x D	5000 x D

Carriage Part Numbers	Dry System, Slimline Type Bearing					Lubricated System, Slimline Type Bearing				
	L1(max)	L2(max)	Ms(max)	Mv(max)	M(max)	L1(max)	L2(max)	Ms(max)	Mv(max)	M(max)
	N	N	Nm	Nm	Nm	N	N	Nm	Nm	Nm
AU 20 195...	180	180	1.6	90 x D	90 x D	400	480	3.5	240 x D	200 x D
AU 28 195...	180	180	2.3	90 x D	90 x D	400	480	5	240 x D	200 x D
AU 25 265...	400	400	4.5	200 x D	200 x D	940	1150	10.5	575 x D	470 x D
AU 35 265...	400	400	6.5	200 x D	200 x D	940	1150	15	575 x D	470 x D
AU 50 265...	400	400	9.5	200 x D	200 x D	940	1150	22	575 x D	470 x D
AU 44 360...	800	800	16	400 x D	400 x D	2000	2400	40	1200 x D	1000 x D
AU 60 360...	800	800	22	400 x D	400 x D	2000	2400	55	1200 x D	1000 x D
AU 76 360...	800	800	29	400 x D	400 x D	2000	2400	70	1200 x D	1000 x D
AU 76 580...	1800	1800	64	900 x D	900 x D	4240	5200	150	2600 x D	2120 x D
AU 120 580...	1800	1800	100	900 x D	900 x D	4240	5200	240	2600 x D	2120 x D

### Calculating the System Load Factor

To calculate the system life, the load factor L<sub>F</sub> should first be calculated using the equation below. Where M<sub>v</sub> & M loads are concerned, the M<sub>v(max)</sub> and M<sub>(max)</sub> for the relevant carriage will need to be determined. This is established by multiplying the figure shown in the table by the spacing of the bearings, D, in metres.

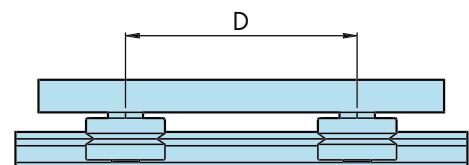

$$L_F = \frac{L_1}{L_{1(max)}} + \frac{L_2}{L_{2(max)}} + \frac{M_s}{M_{s(max)}} + \frac{M_v}{M_{v(max)}} + \frac{M}{M_{(max)}}$$

L<sub>F</sub> should not exceed 1 for any combination of loads.

Once L<sub>F</sub> has been determined for the application, the life is calculated as shown at the bottom of page 59.

# Load/Life Calculations

## Individual 'V' Bearing Calculations

Many systems do not use a standard 4 bearing carriage. In such cases it is necessary to use conventional statics calculations to determine the loading on each bearing in the system, by resolving loads into axial ( $L_A^{*1}$ ) and radial ( $L_R^{*1}$ ) components.

The maximum  $L_A$  and  $L_R$  load capacities for all types of Hepco 'V' Bearing are given in the tables below. Capacities are included for both 'dry' and 'lubricated' conditions - this refers to the 'V' contact, since all bearings are greased internally for life. Values are based on shock-free duty.

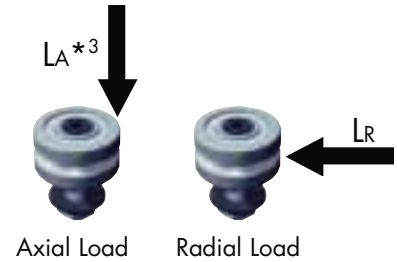

Bearing Part Numbers	Load Capacities for Twin Standard Bearings			
	Dry		Lubricated	
	$L_A$ (max) N	$L_R$ (max) N	$L_A$ (max) N	$L_R$ (max) N
...J 13...	22.5	45	60	120
...J 18...	45	90	125	200
...J 25...	100	200	320	600
...J 34...	200	400	800	1400
...J 54...	450	900	1800	3200

Bearing Part Numbers	Load Capacities for Double Row Standard Bearings			
	Dry		Lubricated	
	$L_A$ (max) N	$L_R$ (max) N	$L_A$ (max) N	$L_R$ (max) N <sup>*6</sup>
...J 18 DR...	45	90	190	600
...J 25 DR...	100	200	400	1500
...J 34 DR...	200	400	900	3000
...J 54 DR...	450	900	2500	5000

Bearing Part Numbers	Load Capacities for Slimline Bearings			
	Dry		Lubricated	
	$L_A$ (max) N	$L_R$ (max) N	$L_A$ (max) N	$L_R$ (max) N
...J 195...	45	90	100	240
...J 265...	100	200	235	575
...J 360...	200	400	500	1200
...J 580...	450	900	1060	2600

The above figures assume that Bearings are used with Slides equal to or larger than the preferred Slide selection for that Bearing size. For details of the preferred sizes, see tables on pages 32-35. For loading of Bearings with smaller Slides, please contact Hepco.

## Calculating the System Load Factor

To calculate the system life, the load factor  $L_F$  should first be calculated using the equation below.

$$L_F = \frac{L_A}{L_{A(max)}} + \frac{L_R}{L_{R(max)}}$$

$L_F$  should not exceed 1 for any combination of loads.

Once  $L_F$  has been determined for each bearing, the life can be calculated as follows:

## Calculating System Life

With  $L_F$  determined for either a 4 bearing carriage or for an individual bearing, the life in km can be calculated using one of the two equations below. In these equations, the Basic Life is taken from the table (right) in respect of the Bearing and the lubrication condition applicable.

### Dry System

$$\text{Life (km)} = \frac{\text{Basic Life}}{(0.03 + 0.97L_F)^2}$$

### Lubricated System

$$\text{Life (km)} = \frac{\text{Basic Life}}{(0.03 + 0.97L_F)^3}$$

Bearings	Basic Life	Basic Life
	Dry	Lubricated
...J 13...	40	50
...J 18...	50	100
...J 18 DR...	50	100
...J 25...	70	50
...J 25 DR...	70	70
...J 34...	100	100
...J 34 DR...	100	250
...J 54...	150	250
...J 54 DR...	150	500
...J 195...	50	100
...J 265...	70	50
...J 360...	100	250
...J 580...	150	200

Example calculations using the methods above are included on pages 61-62.

### \* Notes:

1. The maximum values of  $L_1$ ,  $L_2$ ,  $M_s$ ,  $M$ ,  $M_v$ ,  $L_A$  and  $L_R$ , and the magnitudes of the system Basic Life for each bearing type relate to the performance of complete systems. Tests have shown these figures to be more reliable than working from the theoretical static and dynamic load capacities ( $C$  and  $Co$ ) of the bearings. Values of  $C$  and  $Co$  have been included in tabulated data on the relevant Bearing pages as a means of comparison with other systems.
2. The calculations within this section assume that the linear stroke involves a number of complete bearing revolutions. If the stroke of any application is less than five times the bearing outside diameter, then please calculate the distance travelled as if it moves five bearing diameters per stroke. Systems operating at speeds in excess of 8 m/s may require additional calculation. Please contact Hepco for assistance.
3. For the purposes of the load/life calculations on this page, the axial load  $L_A$  is that load in the axial direction which the bearing can accept from a 'V' slide engaged in its outer ring. Since the line of force is some distance removed from the axis of the bearing, this value is much less than the theoretical axial load capacity which is quoted on the relevant bearing page.
4. In the above calculations, the term lubricated refers to the contact between the slide and bearing 'V's. This lubrication may best be achieved using Hepco Lubricators, Cap Seals or Cap Wipers, however other methods which ensure the presence of a suitable grease or oil in the critical area are acceptable.
5. When a system consists of more than 4 bearings per carriage (e.g. see application examples on pages 9 & 14) it cannot always be guaranteed that the load will share equally between all bearings. In such cases it is recommended that Controlled Height Bearings are specified (where available) and that the system is derated to allow for the life of the most heavily laden bearing.
6. For some sizes of DR bearing, the actual life for applications with mainly  $L_2$ /radial loads may be higher than the calculations indicate. This is because the calculations are simplified for easy use. Please contact Hepco for details in instances where a higher system life is required.



# Load/Life Calculations

## Track Roller Calculations

Systems incorporating **Track Rollers** running on **Flat Tracks** or the flat faces of **Single Edge 'V' Slides** will require a different calculation to determine the load and life. Track Rollers only have a radial load capacity stated as they are not usually loaded axially. Their pure rolling contact with the track means that they do not need to be derated for use in unlubricated applications (although it is recommended that the tracks and rollers be lightly oiled for best performance).

The maximum radial load capacity  $L_R$  for the Hepco range of **Track Rollers** is stated in the table below.



Flat Track  
P 40

Single Edge  
'V' Slides  
P 26-29

Track  
Rollers  
P 41-43

Load Capacities for Track Rollers			
Narrow Rollers	$L_R$ (max) N	Wide Rollers	$L_R$ (max) N
LRN 18...	400	...R 18...	600
LRN 25...	1000	...R 25...	1600
LRN 34...	2000	...R 34...	3200
LRN 54...	5000	...R 54...	8000

## Calculating the System Load Factor

To calculate the roller life, the load factor  $L_f$  should first be calculated using the equation below.

$$L_f = \frac{L_R}{L_{R(max)}}$$

$L_f$  should not exceed 1.

## Calculating Track Roller Life

With  $L_f$  determined for each roller, the life in km can be calculated using the equation below. Please note that the 'Basic Life' for all Track Rollers is 1000 km, so a lookup table is not required.

$$\text{Life (km)} = \frac{1000}{L_f^3}$$

## Load Capacity of the Track Roller Running Surface

In a system using a **Track Roller** running on a flat surface, it may be necessary to reduce the maximum loads applied if the track is not sufficiently hard. All Hepco **Flat Tracks** are hardened, and these can be used in conjunction with Hepco Track Rollers up to the maximum load capacities stated in the table above. Even higher loads up to the static load capacity ( $C_o$  - see **Track Roller** pages) of the bearings are possible without damage.

For softer running faces (such as the rear face of the Hepco **Single Edge 'V' Slides**) the maximum Track Roller loads are reduced as stated in the table below:

Description of Track Roller Running Surface	Track Roller Maximum Load Capacities /N			
	Used with Track Roller Type			
	LRN18... & ... R18...	LRN25... & ... R25...	LRN34... & ... R34...	LRN54... & ... R54...
Hepco Flat Tracks FT...	The load is limited by the $L_R$ (max) figure for the Track Roller			
Rear of Hepco Single Edge Slide	310	510	680	1600

It should be noted that while a softer running face will limit that maximum load that can be exerted by a **Track Roller**, the life of the Track Roller at any given load is not affected.

### \* Notes:

- The values of  $L_R$ , and the system Basic Life for each Roller relate to the performance of complete systems. Tests have proved these figures to be more reliable than working from the theoretical static and dynamic load capacities ( $C$  and  $C_o$ ) of the bearings. Values of  $C$  and  $C_o$  have been included in tabulated data on the relevant Bearing pages as a means of comparison with other systems.
- The calculations within this section assume that the linear stroke involves a number of complete bearing revolutions. If the stroke of any application is less than five times the bearing outside diameter, then please calculate the distance travelled as if it moves five bearing diameters per stroke. Systems operating at speeds in excess of 8 m/s may require additional calculation. Please contact Hepco for assistance.



# Load/Life Calculations

## Example Calculation 1

A machine incorporates a heavy cast component mounted onto a Hepco AU 76 34 L240 CS DR carriage (Standard Carriage with fitted Cap Seals and Double Row Bearings - see p18-19) mounted onto an NM76 P1 Double Edge Spacer Slide (see p24-25). The weight of the cast component and carriage is 50 kg, and the centre of mass is central along the length of the carriage, and 0.07 m from the slide 'V' as shown in the diagram.

The Load Factor  $L_F$  is calculated using the method detailed on page 58:

$$L_1 = M = Mv = 0$$

$$L_2 = 50 \text{ kg} \times 9.81 (\text{gravity}) = 491 \text{ N} \quad M_s = 491 \times 0.07 = 34.4 \text{ Nm}$$

$$L_F = \frac{L_1}{L_{1(\max)}} + \frac{L_2}{L_{2(\max)}} + \frac{M_s}{M_{s(\max)}} + \frac{Mv}{Mv_{(\max)}} + \frac{M}{M_{(\max)}}$$

The values for  $L_{1(\max)}$ ,  $L_{2(\max)}$ ,  $M_{s(\max)}$ ,  $Mv_{(\max)}$  &  $M_{(\max)}$  are taken from the table on page 58.

$$L_F = \frac{0}{3600} + \frac{491 \text{ N}}{6000 \text{ N}} + \frac{34.4 \text{ Nm}}{130 \text{ Nm}} + \frac{0}{3000 \times D} + \frac{0}{1800 \times D} = 0.347$$

The basic life for this system (using SJ34DR bearings in the lubricated condition) is taken from the table on page 59 - this is 250. The system life is calculated as shown on page 59:

$$\text{Life} = \frac{\text{Basic Life}}{(0.03 + 0.97L_F)^3} = \frac{250}{(0.03 + 0.97 \times 0.347)^3} = \underline{\underline{5070 \text{ km}}}$$

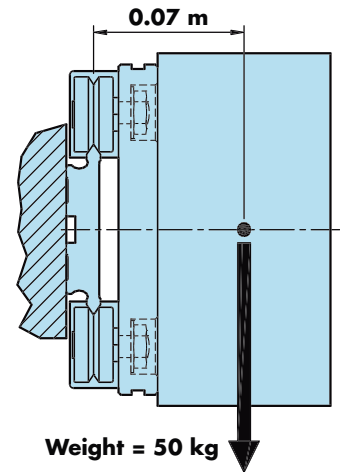

## Example Calculation 2

An overhead transfer system uses a combination of an NLE P3 Single Edge Spacer Slide (see pages 25-26) and an FT 66 33 P3 flat track on either side of a machine bay. 2 off LJ54CDR bearings with CS54 Cap Seals run on the 'V' Slide. 2 off LR54C Track Rollers run on the flat track. A single LRN54E Narrow track roller is on the non-loaded side of both the 'V' slide and Flat Track to retain the moving structure on the slides.

A weight of 400 kg is located centrally on the structure, such that the load is equally distributed between the LJ54's and LR54's, each therefore experiencing a radial load of  $9.81 \times 100 = 981 \text{ N}$ .

The Load Factor  $L_F$  for the 'V' Bearings is calculated using the method detailed on page 59:

$$L_A = 0 \quad L_R = 981 \text{ N}$$

The values for  $L_{A(\max)}$  &  $L_{R(\max)}$  are taken from the table on page 59.

$$L_F = \frac{L_A}{L_{A(\max)}} + \frac{L_R}{L_{R(\max)}} = \frac{0}{2500} + \frac{981 \text{ N}}{5000 \text{ N}} = 0.196$$

The basic life for these LJ54 bearings used in the lubricated condition is taken from the table on page 59 - this is 500. The bearing life is calculated as shown on page 59:

$$\text{Life} = \frac{\text{Basic Life}}{(0.03 + 0.97L_F)^3} = \frac{500}{(0.03 + 0.97 \times 0.196)^3} = \underline{\underline{46,880 \text{ km}}}$$

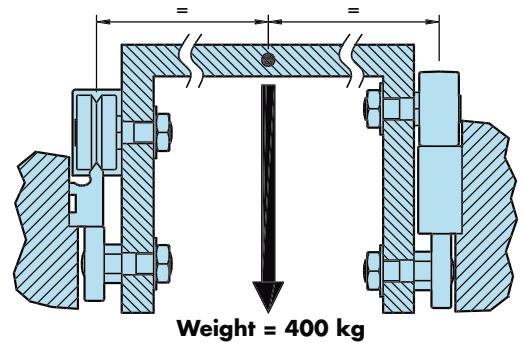

The Load Factor  $L_F$  for the Track Rollers is calculated using the method detailed on page 60. As before,  $L_R = 981 \text{ N}$ :

The value for  $L_{R(\max)}$  is taken from the table on page 60. For the LR54,  $L_{R(\max)}$  is 8000 N.

The Load Factor  $L_F$  is calculated from the equation on page 60 as follows:

$$L_F = \frac{L_R}{L_{R(\max)}} = \frac{981 \text{ N}}{8000 \text{ N}} = 0.123$$

The Track Roller Life is then calculated using the second equation from page 60:

$$\text{Life} = \frac{1000}{L_F^3} = \frac{1000}{0.123^3} = \underline{\underline{537000 \text{ km}}}$$

From this it can be seen that the 'V' bearings are the life determining factor for the system as a whole.

# Load/Life Calculations

## Example Calculation 3

A machine vertical movement uses a Hepco AU 60 360 L280 Carriage (Slimline Carriage without Cap Wipers or Lubricators - see p22-23) mounted onto an NM60...P3 Double Edge Spacer Slide (see p24-25). The slide system is run dry and is raised and lowered by a ball screw as shown. The total mass being raised and lowered is 20 kg.

The load  $F_1$  due to the weight of 20 kg  $\times 9.81 = 196$  N is balanced out by the force  $F_2$  of the ball screw, so no direct load is put onto the slide system. There is a moment load in the M direction which is calculated by taking moments about the slide 'V'

$$M = (196 \text{ N} \times 0.12 \text{ m}) - (196 \text{ N} \times 0.06 \text{ m}) = 11.76 \text{ Nm.}$$

$$L_1 = L_2 = M_s = M_v = 0$$

The Load Factor  $L_F$  is calculated as before with the values for  $L_{1(max)}$ ,  $L_{2(max)}$ ,  $M_{s(max)}$ ,  $M_{v(max)}$  &  $M_{(max)}$  taken from the table on page 58.

$$L_F = \frac{0}{800} + \frac{0}{800} + \frac{0}{22} + \frac{11.76}{400 \times 0.2} + \frac{0}{400 \times 0.2} = 0.147$$

The basic life for this system (using SJ360 bearings in the dry condition) is taken from the table on page 59 - this is 100. The system life is calculated as shown on page 59:

$$\text{Life} = \frac{\text{Basic Life}}{(0.03 + 0.97L_F)^2} = \frac{100}{(0.03 + 0.97 \times 0.147)^2} = \mathbf{3350 \text{ km}}$$

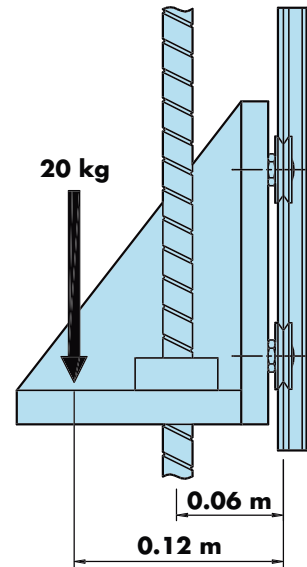

## Example Calculation 4

A testing machine has a horizontal table movement which uses 2 NVE...P1 Single Edge Spacer Slides (see pages 26-27) with 2 off BHJ 18 C NS and 2 off BHJ 18 E NS Blind Hole Standard Bearings (see pages 32-33). Lubrication is provided by 2 off LB18F Lubricators.

The table includes a casting, and the weight is 8 kg which is centrally located with respect to the 4 bearings.

When the table is moving, there is an external load of 80 N which is exerted as shown in the drawing.

The weight of the table exerts a force  $8 \text{ kg} \times 9.81 = 78.5$  N.

This is equally shared between all 4 bearings, so each sees an axial load of 19.6 N.

The external force of 80 N is shared by the 2 concentric bearings. Each sees a radial load of 40N.

The external force also exerts a turning moment which will be balanced by additional axial reaction forces on the bearings.

Taking moments about the 'V' of the concentric side (ignoring the weight reactions which will cancel out) we get:

Counter-clockwise moment:  $80 \text{ N} \times 0.03 \text{ m} = 2.4 \text{ Nm.}$

Clockwise moment:  $2 \times (\text{reaction force on each eccentric bearing}) \times 0.12 \text{ m}$

Since clockwise moment = counter-clockwise moment, reaction force on each eccentric bearing =  $\frac{2.4 \text{ Nm}}{2 \times 0.12 \text{ m}} = 10 \text{ N.}$

Since there is no unbalanced vertical force, the axial reaction on the concentric bearings will be equal and opposite, i.e. -10 N.

The load on the concentric and eccentric bearings is therefore as follows:

Eccentric Bearings:  $L_A = 19.6 + 10 = 29.6 \text{ N}$   $L_R = 0$

Concentric Bearings:  $L_A = 19.6 - 10 = 9.6 \text{ N}$   $L_R = 40 \text{ N}$

The Load Factor  $L_F$  is calculated as in example 2, with the values for  $L_{A(max)}$  &  $L_{R(max)}$  are taken from the table on page 59:

$$L_F \text{ (for concentrics)} = \frac{9.6 \text{ N}}{125 \text{ N}} + \frac{40 \text{ N}}{200 \text{ N}} = 0.277$$

$$L_F \text{ (for eccentrics)} = \frac{29.6 \text{ N}}{125 \text{ N}} + \frac{0}{200 \text{ N}} = 0.237$$

The basic life for these BHJ18 bearings used in the lubricated condition is taken from the table on page 59 - this is 100. The bearing life for the more heavily loaded concentric bearings is calculated as shown on page 59:

$$\text{Life} = \frac{\text{Basic Life}}{(0.03 + 0.97L_F)^3} + \frac{100}{(0.03 + 0.97 \times 0.277)^3} = \mathbf{3,750 \text{ km}}$$

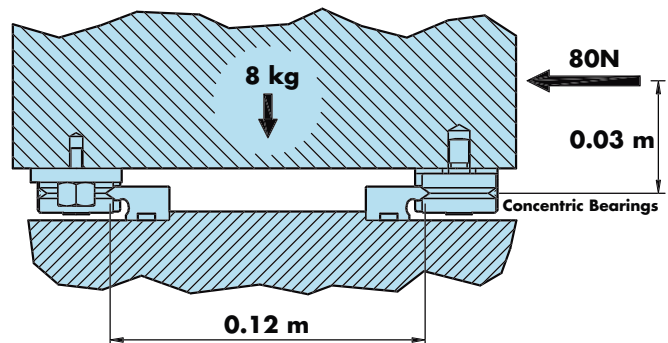

# Deflection of Self-Supporting Slides

When GV3 Slide Beams and Spacer Slides are used as self-supporting beams (see application examples on pages 10, 12 & 14), the Slides will deflect under load and their own weight. Care should be taken when designing an installation to take account of this deflection, by choosing a Slide or Slide Beam which will give both adequate life and satisfactory stiffness for the duty.

The deflection of a Slide or Slide Beam across a span (as shown opposite), will be a maximum at the centre of the span when the load passes over this point. This maximum deflection is given by equation (1):

$$(1)^{*2,3} \quad d = \underbrace{\frac{FL^3}{48EI}}_{\text{Deflection due to the applied load}} + \underbrace{\frac{5L^4Qg}{384EI}}_{\text{Deflection due to the Slide or Slide Beam's weight}}$$

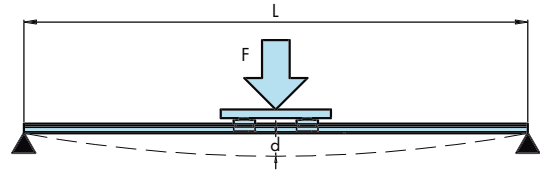

Flange Clamps  
P 39

Slide Beams  
P 30-31

Slides (Spacer)  
P 24-25

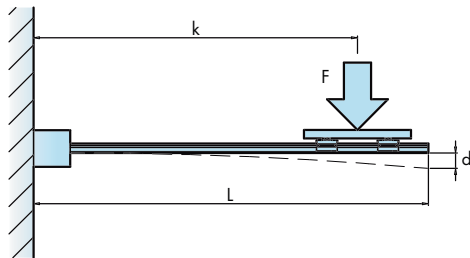

The deflection of a Slide or Slide Beam acting as a cantilever will be a maximum at the free end when the load is at the outermost extremity of its stroke. This maximum deflection is given by equation (2)\*1:

$$(2)^{*1,2\&3} \quad d = \underbrace{\frac{FL^2(3L-k)}{6EI}}_{\text{Deflection due to the applied load}} + \underbrace{\frac{L^4Qg}{8EI}}_{\text{Deflection due to the Slide's weight}}$$

In the equations (1) and (2) above, L, k and d are the dimensions shown in the relevant diagrams (in mm) and F is the load applied in Newtons. The term EI is the product of the Slide or Slide Beam material's Young's modulus and the section moment of inertia, which is a constant relating to the stiffness of the Slide section in the orientation of the application.

The term Q is the mass of the Slide in kg/mm and g is the acceleration due to gravity (=9.81 m/s<sup>2</sup>).

The values of EI and Q for the various sections are given in the table below:

Slide Part Number	EI (Section Stiffness - Nmm <sup>2</sup> )		Q = Section Mass kg/mm
	Horizontal*3	Vertical*3	
NS 25...	4.2 x 10 <sup>8</sup>	1.2 x 10 <sup>9</sup>	0.0015
NS 35...	7.5 x 10 <sup>8</sup>	4.6 x 10 <sup>9</sup>	0.0023
NS 50...	1.1 x 10 <sup>9</sup>	1.55 x 10 <sup>10</sup>	0.0032
NM 44...	1.7 x 10 <sup>9</sup>	9.8 x 10 <sup>9</sup>	0.0035
NM 60...	2.6 x 10 <sup>9</sup>	3 x 10 <sup>10</sup>	0.0055
NM 76...	3.4 x 10 <sup>9</sup>	6.8 x 10 <sup>10</sup>	0.007
NL 76...	1.1 x 10 <sup>10</sup>	8.6 x 10 <sup>10</sup>	0.010
NL 120...	1.8 x 10 <sup>10</sup>	4.3 x 10 <sup>11</sup>	0.015

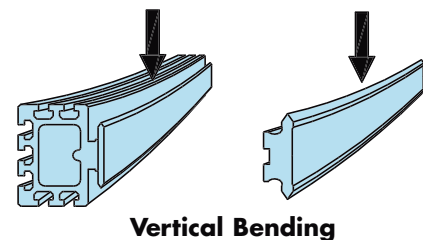
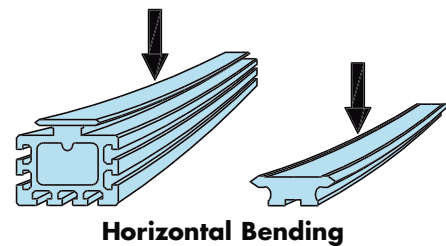

Slide Beam Part Number	EI (Section Stiffness - Nmm <sup>2</sup> )		Q = Section Mass kg/mm
	Horizontal*3	Vertical*3	
SB S 35...	5.8 x 10 <sup>10</sup>	9.5 x 10 <sup>10</sup>	0.0068
SB S 35 ...L... (lightweight)	3.2 x 10 <sup>10</sup>	5.6 x 10 <sup>10</sup>	0.0043
SB S 50...	5.8 x 10 <sup>10</sup>	1 x 10 <sup>11</sup>	0.0072
SB S 50 ...L... (lightweight)	3.2 x 10 <sup>10</sup>	6.2 x 10 <sup>10</sup>	0.0047
SB M 44...	1.5 x 10 <sup>11</sup>	2.1 x 10 <sup>11</sup>	0.0104
SB M 60...	1.5 x 10 <sup>11</sup>	2.3 x 10 <sup>11</sup>	0.0112
SB M 76...	1.5 x 10 <sup>11</sup>	2.5 x 10 <sup>11</sup>	0.0129

### \* Notes:

1. The calculation for the deflection of a cantilevered slide assumes that the slide is held absolutely rigidly at one end. This is often difficult to achieve in practice, and it is usual to allow for additional deflection due to the compliance of the support. Hepco will supply such data on flange clamps on request.
2. The deflections calculated are for static loads. In some situations dynamic loading may increase the amount of bend.
3. For maximum stiffness, the slide or slide beam section should be arranged such that the bending mode with the higher value for EI resists bending. Care should be taken in such applications to ensure that offset loads do not cause excessive bending in the weaker perpendicular plane.

## Rack Driven Carriage - Drive Calculations

The following section should be used by customers who require a system using a [Rack Driven Carriage](#) with fitted [Gearbox or Geared Motor](#), and need to calculate the speeds and forces produced by the system. Drive calculations for systems using [Hepco Belt Driven Carriages](#), Belts and Pulleys are identical to those in the **Hepco DLS Driven Linear System**. Please refer to this catalogue as required. Customers using other combinations of components should use the data within this catalogue and conventional calculations to rate their systems. Hepco will be pleased to assist in this selection process, on request.

### How to Select the Right Rack Drive Carriage + Geared Motor Combination

The method of rating detailed below uses a simplified version of the definitive calculations. It will select the correct system in the vast majority of cases. For unusual and borderline cases the application may be referred to Hepco for a more precise rating. To choose the right system configuration for a given duty, follow the 3 stages outlined below:

- 1) Choose the size of [Rack Driven Carriage](#) required, considering the following factors: i) The load to be supported by the Carriage (see pages 58-59 for details of rating); ii) the linear force which is required (an AURD...34... has a maximum rated linear force of 400 N, while for an AURD...54... this figure is typically 600-700 N, depending on the gear ratio); and iii) the physical dimensions of the unit (see pages 48-49).
- 2) The user should then examine the relevant table to identify combinations of motor size, number of poles and gearbox ratio which have a suitable working speed range and linear driving force. If a unit is intended to run at a single speed, it is recommended that a unit with a nominal speed close to the working speed is chosen. (continued on p65)

AURD...34... with WG3 AC Geared Motor/Gearbox												
Nominal Speed m/s at 50Hz* <sup>1</sup>	Motor Poles	Gear Ratio	Travel per motor rev /mm	Nominal Linear Force /N for system with motor size* <sup>1</sup>						Rated Linear Force (N) For Critical Components* <sup>2</sup>		
				56 S	56 L	63 S	63 L	71 S	71 L	Gears	Bearings	Rack & Pinion
1.23	2	5	26.4	35	56	99	146	228	348	440	740	<b>400</b>
0.88	2	7	18.8	61	91	142	211	322		498	740	<b>400</b>
0.62	2	10	13.2	90	129	211	301	448		526	740	<b>400</b>
0.59	4	5	26.4	56	99	138	219	309	<i>446</i>	483	740	<b>400</b>
0.51	2	12	11.0	112	159	245	356			541	740	<b>400</b>
0.42	4	7	18.8	86	142	202	309	<i>446</i>		543	740	<b>400</b>
0.41	2	15	8.8	138	192	301	<i>446</i>			526	740	<b>400</b>
0.35	2	18	7.3	168	232	365				511	740	<b>400</b>
0.29	4	10	13.2	129	206	292	<i>446</i>			573	740	<b>400</b>
0.26	2	24	5.5	217	298					526	740	<b>400</b>
0.25	4	12	11.0	155	245	344				588	740	<b>400</b>
0.21	2	30	4.4	258	352					511	740	<b>400</b>
0.2	4	15	8.8	189	296	<i>446</i>				573	740	<b>400</b>
0.16	2	38	3.5	323	<i>440</i>					529	740	<b>400</b>
0.16	4	18	7.3	224	348					558	740	<b>400</b>
0.13	2	50	2.6	376						416	740	<b>400</b>
0.12	4	24	5.5	284	<i>446</i>					573	740	<b>400</b>
0.1	4	30	4.4	331						573	740	<b>400</b>
0.08	4	38	3.5	<i>446</i>						603	740	<b>400</b>

### Notes

\*1 The [Rack Driven Carriage](#) with the AC [Geared Motor](#) will produce the Nominal Linear Force at speeds ranging from 50 to 120% of the Nominal Speed. Units will perform with a lower force and duty cycle over a much wider speed range from 10% to 180% of the Nominal Speed.

- \*2 There are 3 mechanical elements which limit the driving force which can be generated by a [Rack Driven Carriage](#). These are:
- i) The torque capacity of the gears within the gearbox (based on a service factor of 1.4 which corresponds to fast operation for 8 hours per day). Allowable forces may be either increased or reduced for duties which are less or more severe than this.
  - ii) The load capacity of the gearbox bearings. The torque reaction has been calculated assuming the [pinion](#) diameter and shaft length of the [Rack Driven Carriage](#). For other designs, the linear force will be different.
  - iii) The continuous linear force rating for a well lubricated [Rack](#) and [Pinion](#).

In each of the tables, all of these figures are shown (for the benefit of those using components in other ways), but the smallest of the three factors will limit the performance for [Rack Driven Carriage](#) applications. This limiting factor is shown in **bold** text. Some of the combinations of AC motor and gearbox produce a linear force which is higher than the limiting mechanical element is rated for. These combinations are shown in *italic text*. These combinations may be permissible, depending on the duty. Please contact Hepco for details.



# Rack Driven Carriage - Drive Calculations

- 3) In many cases, there will be more than one combination which will satisfy the speed and force requirements. In these cases, the following secondary factors may be considered:
- i) For arduous applications, it is best to select the combination with the highest rated linear force for the gears.
  - ii) For gearbox ratios of less than 29:1, the motor can be back-driven through the [gearbox](#). This may be useful as it will allow the axis to be manually positioned with the power switched off. In some cases, however (for instance in lifting applications) back-driving may be undesirable. If this is the case, specify the electro-magnetic brake option or select a higher gearbox ratio.
  - iii) Two pole [motors](#) will be lighter than four pole for a given power.
  - iv) For best dynamic performance, use a four pole [motor](#). This will give sharper acceleration and more dynamic performance than a two pole motor driving through a gearbox with a higher ratio. For a given load, a more powerful motor will generally accelerate the system more quickly than a less powerful one, but the benefit of increasing power will be small if loads are light.
  - v) Four pole [motors](#) keep the speed in the gearbox down, minimising heating and maximising life.
  - vi) The marginal cost of extra motor power is low on an AC system. If in doubt between two sizes it is often best to specify larger, as there will usually be only a small extra cost.

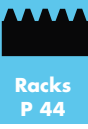

AURD...54... with WG4 AC Geared Motor/Gearbox										
Nominal Speed m/s at 50Hz*1	Motor Poles	Gear Ratio	Travel per motor rev /mm	Nominal Linear Force /N for system with motor size*1				Rated Linear Force (N) For Critical Components*2		
				63 S	63 L	71 S	71 L	Gears	Bearings	Rack & Pinion
1.17	2	6.75	25.1	86	140	227	360	<b>539</b>	700	950
0.99	2	8	21.2	110	167	267	427	<b>630</b>	700	950
0.79	2	10	17.0	147	220	360	527	<b>666</b>	700	950
0.66	2	12	14.1	177	260	427	627	<b>630</b>	700	950
0.57	4	6.75	25.1	126	217	327	460	<b>602</b>	700	950
0.53	2	15	11.3	227	360	499	762	<b>648</b>	700	950
0.48	4	8	21.2	163	263	360	560	703	<b>700</b>	950
0.4	2	20	8.5	302	435	662		<b>666</b>	700	950
0.38	4	10	17.0	210	360	460	693	743	<b>700</b>	950
0.32	2	25	6.8	362	518			<b>612</b>	700	950
0.32	4	12	14.1	247	393	560		703	<b>700</b>	950
0.27	2	30	5.7	436	622			<b>648</b>	700	950
0.25	4	15	11.3	327	493	693		723	<b>700</b>	950
0.2	2	40	4.2	547	775			<b>648</b>	700	950
0.19	4	20	8.5	427	660			743	<b>700</b>	950
0.16	2	50	3.4	674				703	<b>700</b>	950
0.15	4	25	6.8	493	760			<b>683</b>	700	950
0.13	4	30	5.7	593				723	<b>700</b>	950
0.1	4	40	4.2	727				723	<b>700</b>	950

## How to Select the Right Rack Drive Carriage + Gearbox Combination

The approach is similar to that used when selecting the AC [geared motor](#).

The actual linear force which is generated by the system will depend on the torque generated by the motor, the gearbox efficiency, the [rack](#) and [pinion](#) drive efficiency, the reduction ratio, and the carriage friction. This can be calculated using the following equation:

$$\text{Linear Force (N)} = \left( \frac{\tau_m \times \eta_g \times \eta_r \times R_r}{P_r} \right) - F_c$$

In the above equation  $\tau_m$  is the torque generated by the motor in Nm,  $\eta_g$  is the [gearbox](#) efficiency (this varies between ratios and speeds, but is typically 0.9 - 0.75. Contact Hepco for full data),  $\eta_r$  is the [rack](#) and [pinion](#) drive efficiency (~0.9),  $R_r$  is the gearbox reduction ratio,  $P_r$  is the pinon radius in metres (= 0.021 m for the AURD ...34... and = 0.027 m for the AURD...54...), and  $F_c$  is the carriage friction in Newtons (~25 N for the AURD ...34... and ~40 N for the AURD ...54...).

The linear force which can be generated by the [Rack Driven Carriage](#) will be limited by the lowest of the Rated Linear Force for the Gears, Bearings and [Rack & Pinion](#) (as detailed in the tables above and on page 64). Customers should ensure that the motor torque selected does not overload the mechanical components.

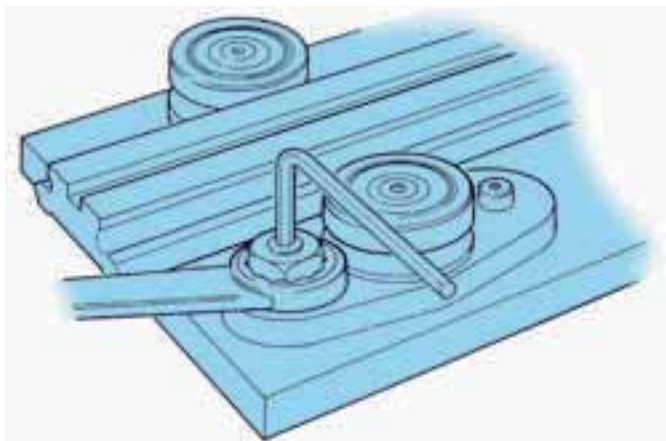
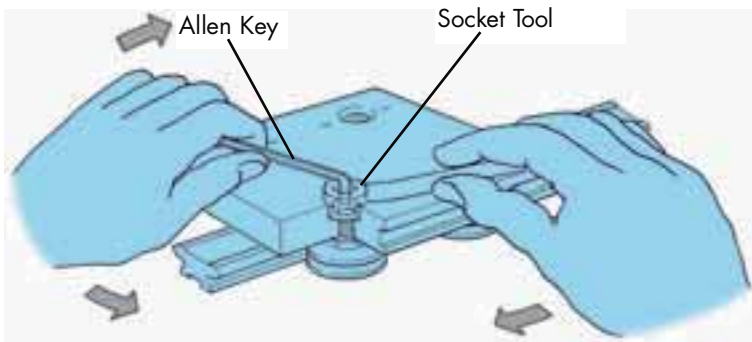
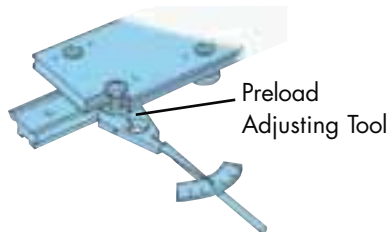
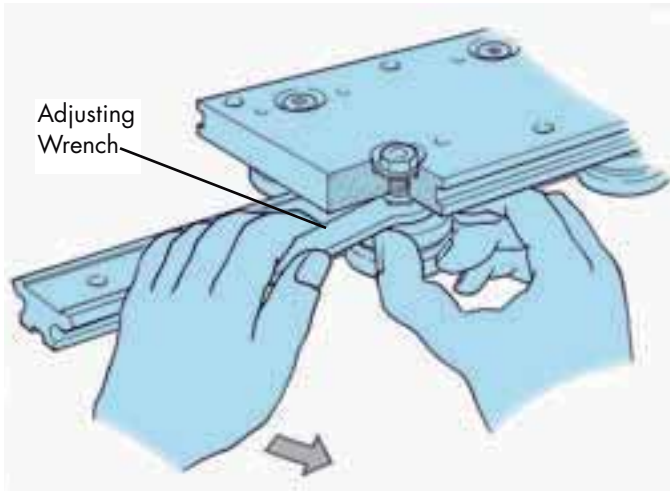

## Through Fixing Type Bearings & Track Rollers

Having loosely assembled the components (minus load), the Concentric Bearings should be fully tightened and the Eccentric Bearings tightened just sufficiently to permit adjustment.

The Hepco Adjusting Wrench should then be engaged with hexagon flanges of the Eccentric Bearings and gradually turned until the Slide or Track is captivated between each pair of Bearings such that there is no apparent play, but with minimal pre-load. Each pair of Bearings should then be checked for correct pre-load by rotating one of them between forefinger and thumb with the Slide or Track stationary so that the Bearing skids against it. A degree of resistance should be felt, but the Bearing should turn without difficulty.

When all Eccentric Bearings have been adjusted and tested in this manner, the fixing nuts should be fully tightened to the recommended torque settings as in the table on page 67, then checked again for pre-load as before.

Please note that too much pre-load will shorten the life of the system. Customers not familiar with this setting procedure, may wish to purchase a Preload Adjusting Tool (available for Standard Bearings only), for use as a training aid and as a means of checking by the quality control department.

## Alternative means of adjustment

The Eccentric Bearings may also be adjusted using a standard Allen key and Hepco Socket Tool. This method permits re-adjustment without first having to remove Cap Seals or Cap Wipers; however, extreme care should be taken not to induce excessive pre-load which can only be judged in this case from the resulting friction of the system. Due to the reduced control associated with this method, it is only recommended when the Adjusting Wrench method is not possible.

## Blind Hole Fixing Type Bearings & Track Rollers

The Concentric Blind Hole Fixing Bearings or Track Rollers are simply screwed into tapped holes in the mounting surface and tightened down using the Hepco Adjusting Wrench.

Each Eccentric Bearing or Roller should be located by means of the two screws provided and tightened just sufficiently to still enable adjustment via the eccentric hexagon bush. The same basic procedures as outlined for the Through Fixing Type should be used to ensure that the correct level of pre-load is applied before finally tightening down the fixing screws.

# System Assembly and Adjustment\*



## Through hole fixing

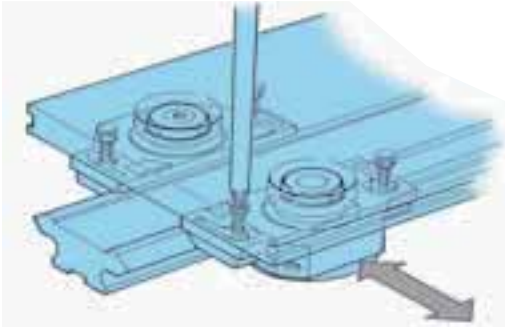

## Tapped hole fixing

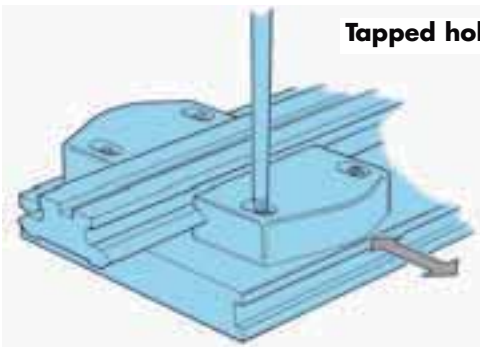
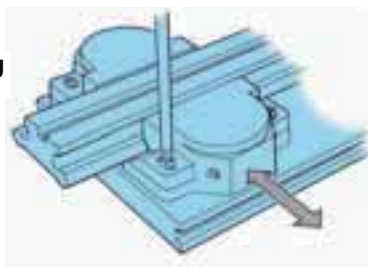

## Tapped hole fixing

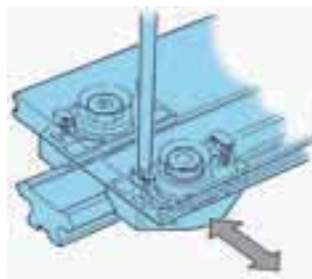

## Through hole fixing

## Cap Seals

Fitting of the **Cap Seals** should be carried out after **Bearing Adjustment** has been completed.

To fit the Cap Seals over the Bearings, the **Carriage** should be removed from the **Slide**, then the Cap Seals loosely assembled to the carriage plate utilising either the Through Hole fixing facility which is the default method for Hepco Carriages, or the Tapped Hole fixing facility which requires tapped holes to be provided in the carriage plate. Two sets of plastic inserts are included with each Cap Seal to cater for both methods.

The Slide should be re-engaged with the Carriage and each Cap Seal adjusted in, until the felt wipers just make contact with the Slide 'V' surface until smearing of the lubricant is observed when the system is operated. When adjusting the Cap Seal using the Through Hole fixing method, care should be taken to hold the plastic inserts to prevent them from moving whilst the screws are tightened.

Greater sealing effect, at the expense of increased friction, may be achieved by adjusting each Cap Seal body in further until it's 'V' profile makes contact with the 'V' profile of the Slide.

The fixing screws should be fully tightened and each Cap Seal charged with a No. 2 Lithium soap-based grease until grease is seen to overflow.

Male grease connector, part No. CSCHF 4034 or complete gun is available from Hepco if required.

## Cap Wipers

Fitting of the **Cap Wipers** should be carried out after **Bearing adjustment** has been completed.

To fit the Cap Wipers over the Bearings, the **Carriage** should be removed from the **Slide**, then the Cap Wipers loosely assembled to the carriage plate utilising either the Tapped Hole fixing facility which is the default method for Hepco Slimline Carriages, or the Through Hole fixing facility which requires slotted clearance holes to be provided in the carriage plate for adjustment.

The Slide should then be re-engaged with the Carriage and each Cap Wiper adjusted in, until the felt wipers just make contact with the Slide 'V' surface until smearing of the lubricant is observed when the system is operated.

The fixing screws should be fully tightened and each Cap Wiper charged with a No. 2 Lithium soap-based grease until grease is seen to overflow.

Male grease connector, part No. CSCHF 4034 or complete gun is available from Hepco if required.



Bearings  
P 32-35



Cap Seals  
P 36



Cap Wipers  
P 37



Carriages  
P 18-23



Slides  
P 24-31



Track  
Rollers  
P 41-43

## Bearing/Track Roller Adjusting Tools and Tightening Torques

When ordering individual components for the first time, an Adjusting Wrench or Socket Tool should also be ordered - these are only available from Hepco.

	Bearing/Roller Type								
	... 13 ...	... 195 ...	... 18 ...	... 265 ...	... 25 ...	... 360 ...	... 34 ...	... 580 ...	... 54 ...
<b>Adjusting Wrench</b>	AT13	AT18	AT18	AT25	AT25	AT34	AT34	AT54	AT54
<b>Socket Tool</b>	-	RT6	RT6	RT8	RT8	RT10	RT10	RT14	RT14
<b>Preload Adjusting Tool</b>	ST13	-	ST18	-	ST25	-	ST34	-	ST54
<b>Fixing Nut Torque</b>	2 Nm	7 Nm	7 Nm	18 Nm	18 Nm	33 Nm	33 Nm	90 Nm	90 Nm

\*A guide to installation and adjustment of other Hepco components may be found on the individual component pages as relevant.



# Technical Specifications

## 'V' Slides

Material and Finish: High carbon bearing steel AISI 52100, hardened on 'V' faces to 58-62 Rockwell 'C' scale. Those areas which are ground have N5 surface finish. Other areas have a chemical black finish.

## Flat Tracks

Material and Finish: Carbon steel, hardened on all faces to 58-62 Rockwell 'C' scale. Those areas which are ground have N5 surface finish. Other areas have a chemical black finish.

## Bearings & Track Rollers

Bearing Raceways and Balls: Carbon-chromium bearing steel AISI 52100, hardened and tempered.  
 Shields: Steel  
 Seals: Nitrile rubber.  
 Cage: Plastic.  
 Studs: High Tensile Steel with tensile strength = 695 N/mm<sup>2</sup>. Chemical black finish.  
 BH... 'E' Base Plate: Cast Steel with chemical black finish.  
 Temperature Range: -20°C to +120°C

## Carriage Plates & Flange Clamps

Material: High Strength Aluminium Alloy  
Finish: Clear Anodised to 15µm thickness.

## Carriage Plate & Slide Counterbore Plugs

Material: Plastic

## Cap Seals

Material: Body: Thermoplastic elastomer  
 Inserts: Impact resistant plastic  
 Wipers: Felt  
 Temperature Range: -20°C to +60°C

## Cap Wipers & Lubricators

Material: Impact resistant plastic with felt wiper  
Temperature Range: -20°C to +60°C

## Frictional Resistance for 'V' Slide Systems

Coefficient of friction (without Cap Seals, Cap Wipers or Lubricators) = 0.02  
Cap Seals and Lubricators add friction as follows:

4 Cap Seals or Wipers per Carriage	CS18 or CW195 = 4 N, CS34 or CW360 = 15 N, LB12 = 1 N, LB25 & LB265 = 2.5 N LB54 & LB580 = 4 N	CS25 or CW265 = 7 N, CS54 or CW580 = 28 N LB20 & LB195 = 1.5 N LB44 & LB360 = 3 N,
2 Lubricators per Carriage		

## External Lubrication

Cap Seals and Cap Wipers should be lubricated with grease NLGI consistency No. 2  
Lubricators should be oiled using 68 cSt viscosity or similar oil. Food compatible lubricants can also be used.

## Maximum Linear Speeds for 'V' Slides & Bearings and Flat Tracks & Rollers

Unlubricated 'V' Slides =	2 m/s	} Higher speeds are possible. Speed depends upon stroke, duty and environmental conditions.
Lubricated 'V' Slides & all Flat track applications =	8 m/s	

Material specifications may change for reasons of technical advantage or availability.

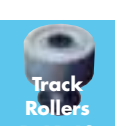



## CAD and Catalogue Request Form

Please send me the:

Hepco Slide Systems CAD Library set, covering GV3, HDS, PRT, HPS, SL2, DLS, MCS and Dual Vee products in both .DWG and .DXF formats.

- HDS      Heavy Duty Slide System Catalogue
- PRT      Ring Slides and Track System Catalogue
- HPS      Powerslide-2 Guided Rodless Cylinder Catalogue
- SL2      Stainless Steel Based Slide System Catalogue
- DLS      Linear Transmission and Positioning System Catalogue
- LoPro    Aluminium Based Slide System Catalogue
- BSP      Ballscrew Premier Catalogue
- DTS      Driven Track System Catalogue
- Dual Vee   Single Edge Slide System Catalogue
- MCS      Aluminium Frame and Machine Construction System Catalogue
- SH      Shock Absorbers Catalogue

Name \_\_\_\_\_

Company \_\_\_\_\_

Address \_\_\_\_\_

\_\_\_\_\_

\_\_\_\_\_

Postcode \_\_\_\_\_

Tel \_\_\_\_\_

Fax \_\_\_\_\_

E-mail \_\_\_\_\_

**Please photocopy this form and fax it to Hepco on  
01884 243500**

# HepcoMotion® Product Range



# BishopWisecarver Product Range

HepcoMotion® – Exclusive European partners and distributors for Bishop-Wisecarver since 1984.



For further information on HepcoMotion® products – please request our leaflet 'FPL'



**HepcoMotion®**

Lower Moor Business Park, Tiverton Way, Tiverton, Devon, England EX16 6TG  
Tel: +44 (0)1884 257000 Fax: +44 (0)1884 243500  
E-mail: [sales@hepcotion.com](mailto:sales@hepcotion.com)

CATALOGUE No.GV3 07 UK © 2005 Hepco Slide Systems Ltd.

Reproduction in whole or part without prior authorisation from Hepco is prohibited. Although every effort has been made to ensure the accuracy of the information in this catalogue, Hepco cannot accept liability for any omissions or errors. Hepco reserves the right to make alterations to the product resulting from technical developments.

Many Hepco products are protected by: Patents, Copyright, Design Right or Registered Design. Infringement is strictly prohibited and may be challenged in law. The Customer's attention is drawn to the following clause in Hepco's conditions of sale:

'It shall be the Customer's sole responsibility to ensure that goods supplied by Hepco will be suitable or fit for any particular application or purpose of the Customer, whether or not such application or purpose is known to Hepco. The Customer will be solely responsible for any errors in, or omissions from, any specifications or information the Customer provides. Hepco will not be obliged to verify whether any such specifications or information are correct or sufficient for any application or purpose.'

Hepco's full conditions of sale are available on request and will apply to all quotations and contracts for the supply of items detailed in this catalogue.

HepcoMotion is the trading name of Hepco Slide Systems Ltd.



INVESTOR IN PEOPLE

